

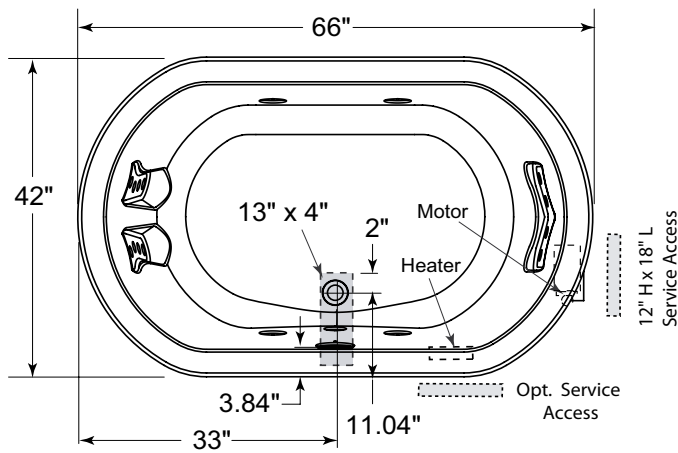

## Duetta™ 6642 WHIRLPOOL BATH

- EE60 Duetta™ 6642 Whirlpool Bath with Chromatherapy Right Hand
- EE65 Duetta™ 6642 Whirlpool Bath with Illumatherapy™ Right Hand

- Center Drain Location
- Accessories / Hardware:
  - TheraPro™ Jet Rings Kit: #D095
  - Sch 40, Rotary Drain Kit: #DA34
- Trim Kit Finishes Available:
  - (827) – Chrome
  - (898) – Brushed Chrome
  - (815) – Satin Nickel
  - (829) – Bright Brass
  - (805) – Platinum
  - (826) – Brushed Nickel
  - (845) – Oil Rubbed Bronze



**Product Shown: Duetta™ Whirlpool Bath Right Hand Shown Model: EE65**

\* Measurements inside unit represent cutout in floor to allow for drain/overflow.

Minimum Service Access dimensions given.

### INSTALLATION NOTES

Refer to installation instructions included with fixture before beginning installation. Please confirm product availability and specifications before commencing with any installation work.

PRODUCT SPECIFICATIONS AND AVAILABILITY ARE SUBJECT TO CHANGE WITHOUT NOTICE.

## Technical Specifications

### DIMENSIONS

66" L x 42" W x 26" H  
(1676 mm) L x (1067 mm) W x (660 mm) H

### DRAIN/OVERFLOW

A: 18.4" (467 mm) B: 11" (279 mm)

### CUTOUT

Template Provided Part Number: DA07000

### TOTAL WEIGHT

1106 lb (502 kg) / 57.5 lb/ft<sup>2</sup> (281 kg/m<sup>2</sup>)

### OPERATING GALLONAGE

93 U.S. Gal. (352 Liters)  
Min. 90 U.S. Gal. (341 Liters)  
Max: 95 U.S. Gal. (360 Liters)

### PRODUCT WEIGHT

EE60: TBD  
EE65: 117 lbs (53 kg)

### SKIRT MOUNTING

Not Available

### ELECTRICAL SPECIFICATIONS

Requires a dedicated GFCI protected separate circuit.

Motor/Pump: 120 VAC, 20 AMP, 60 Hz.

RapidHeat™: 115 VAC, 15 AMP, 60 Hz.

### HEATER (STANDARD)

Requires a dedicated GFCI protected separate circuit.

RapidHeat™: P/N S750000

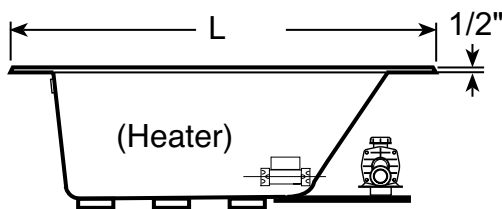

SIDE VIEW

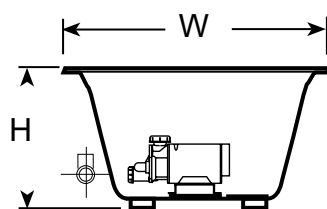

(Motor)  
END VIEW

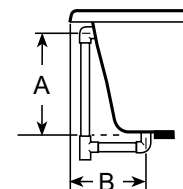

DRAIN/OVERFLOW