



Portfolio® is a registered trademark of LF, LLC. All Rights Reserved.

ITEM #0388009

8-LIGHT CHANDELIER

MODEL #23384-026

Français p. 11

Español p. 21

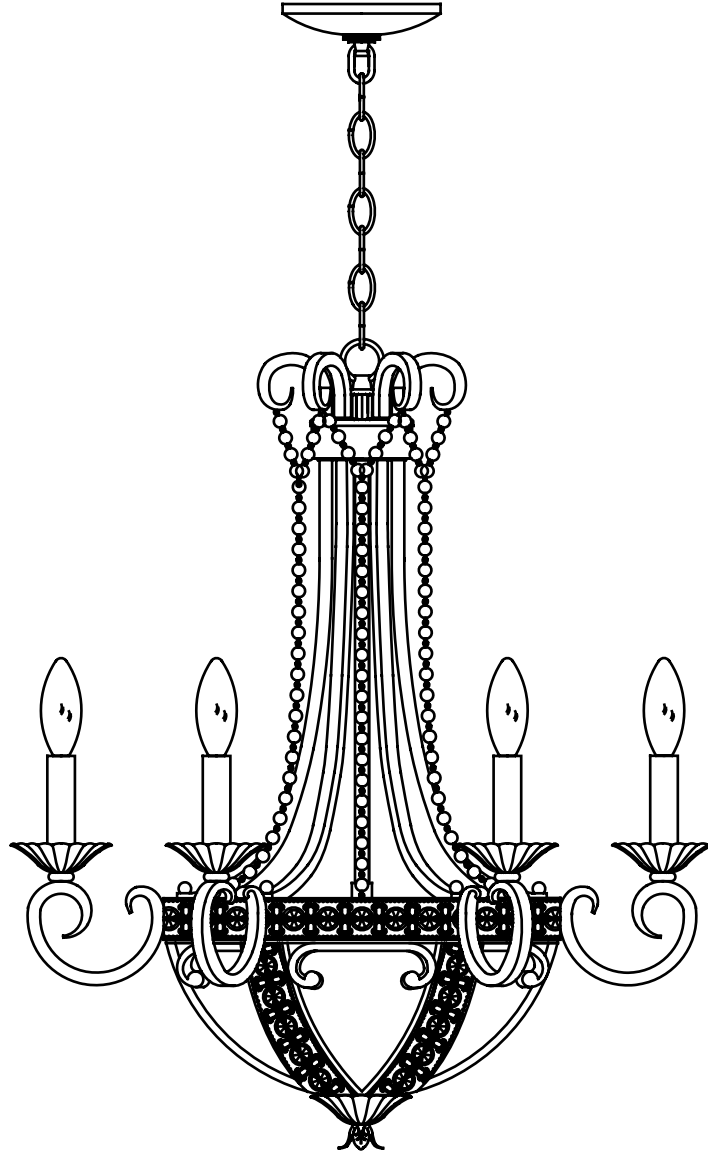

ATTACH YOUR RECEIPT HERE

Serial Number _____ **Purchase Date** _____



Questions, problems, missing parts? Before returning to your retailer, call our customer service department at 1-800-643-0067, 8 a.m. - 6 p.m., EST, Monday - Thursday, 8 a.m. - 5 p.m., EST, Friday.

PACKAGE CONTENTS

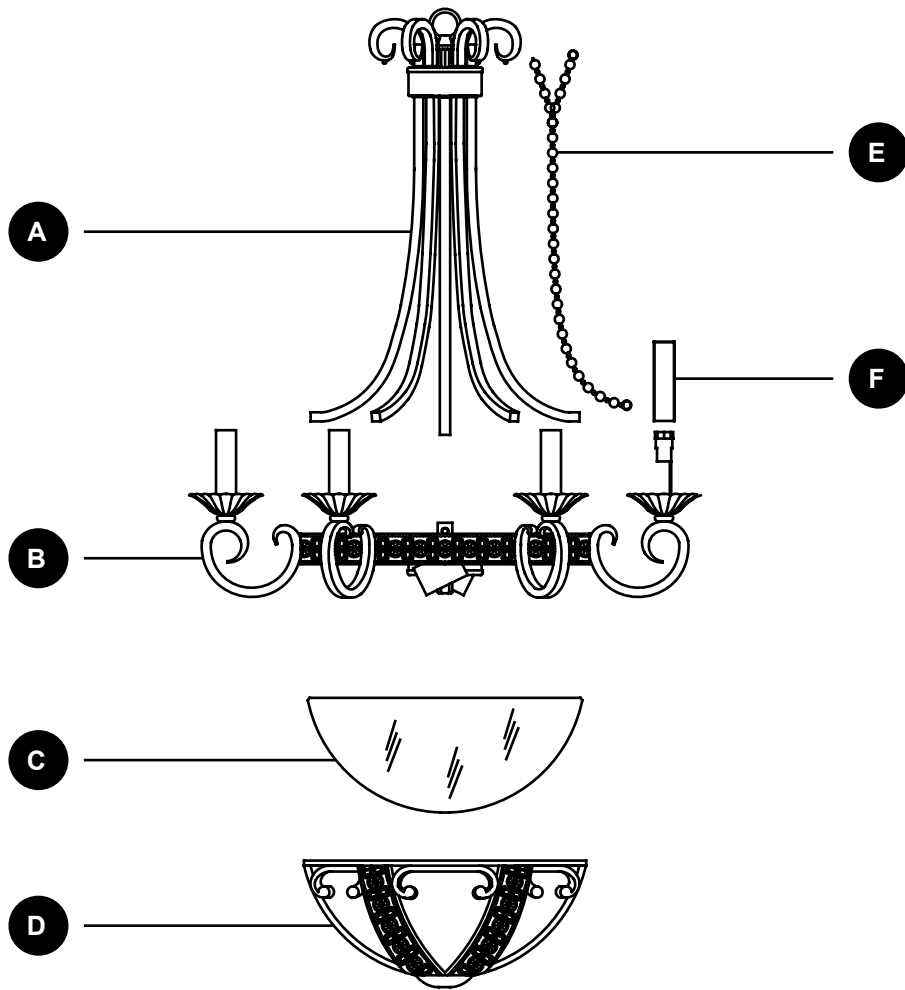

Part	Description	Quantity
A	Arm	6
B	Fixture Body	1
C	Shade	1
D	Decorative Frame	6
E	Bead Chain	6
F	Candle Cover	6

HARDWARE CONTENTS (shown actual size)

AA

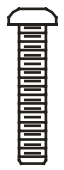

Outlet Box Screw
Qty. 2

BB

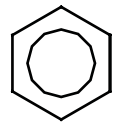

Hex Nut
Qty. 5

CC



Crossbar
(Not shown to size)
Qty. 1

DD



Mounting Nipple
(Not shown to size)
Qty. 1

EE

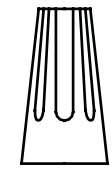

Wire Connector
Qty. 3

FF

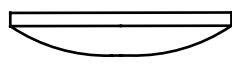

Canopy
(Not shown to size)
Qty. 1

GG

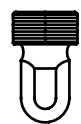

Canopy Loop
(Not shown to size)
Qty. 1

HH



Chain
(Not shown to size)
Qty. 1

II

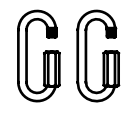

Twist-Lock Link
(Not shown to size)
Qty. 2

JJ

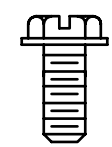

Green Ground Screw
(preassembled to crossbar (CC))
(Not shown to size)
Qty. 1

KK



Collar Loop Ring
(preassembled to crossbar (CC))
Qty. 1

LL



Ball Nut with Stud
Qty. 6

MM

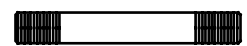

Nipple
Qty. 1

NN

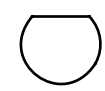

Ball Nut
Qty. 1

OO

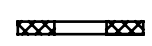

Rubber Washer
Qty. 1

PP

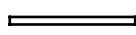

Spacer
Qty. 1

QQ

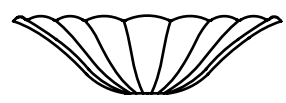

Flower Cup
Qty. 1

RR



Decorative Flower
Qty. 1

SAFETY INFORMATION

Please read and understand this entire manual before attempting to assemble operate or install the product.

WARNING

- RISK OF ELECTRIC SHOCK - Before beginning installation, turn off electricity at the circuit breaker box or the main fuse box.
- RISK OF FIRE - Use bulbs specified by the markings and/or labels on the fixture.

CAUTION

- For your safety, read instructions completely before beginning installation.
- If in doubt about electrical installation, consult a licensed electrician.
- Turn off electricity to fixture before replacing the bulb(s).

PREPARATION

Before beginning assembly of product, make sure all parts are present. Compare parts with package contents list and diagram above. If any part is missing or damaged, do not attempt to assemble the product. Contact customer service for replacement parts.

Estimated Assembly Time: 25 - 30 minutes

Tools Required For Assembly (not included): Flathead screwdriver, Phillips screwdriver, Pliers, Electrical tape, Wire cutters, six 60-watt max. candelabra-base bulbs and two 60-watt max. A19-base bulbs.

Helpful Tools (not included): Wire strippers, Ladder

ASSEMBLY INSTRUCTIONS

1. Connect arms (A) and fixture body (B) using ball nuts with studs (LL).

HARDWARE USED

LL Ball Nut with Stud  x 6

2. Connect bead chains (E) to arms (A) and fixture body (B).

Thread hex nut (BB) to nipple (MM) and then connect to coupling nut on fixture body (B). Insert the shade (C), rubber washer (OO) and spacer (PP) over nipple (MM) and then secure with hex nut (BB). Install two 60-watt max. A19 medium-base bulbs (not included) to fixture body (B).

Insert decorative frame (D) onto nipple (MM) through center hole, and secure with hex nut (BB).

Insert flower cup (QQ) and decorative flower (RR) over nipple (MM) and secure with ball nut (NN).

HARDWARE USED

BB Hex Nut  x 3

MM Nipple  x 1

NN Ball Nut  x 1

OO Rubber Washer  x 1

PP Spacer  x 1

QQ Flower Cup  x 1

RR Decorative Flower  x 1

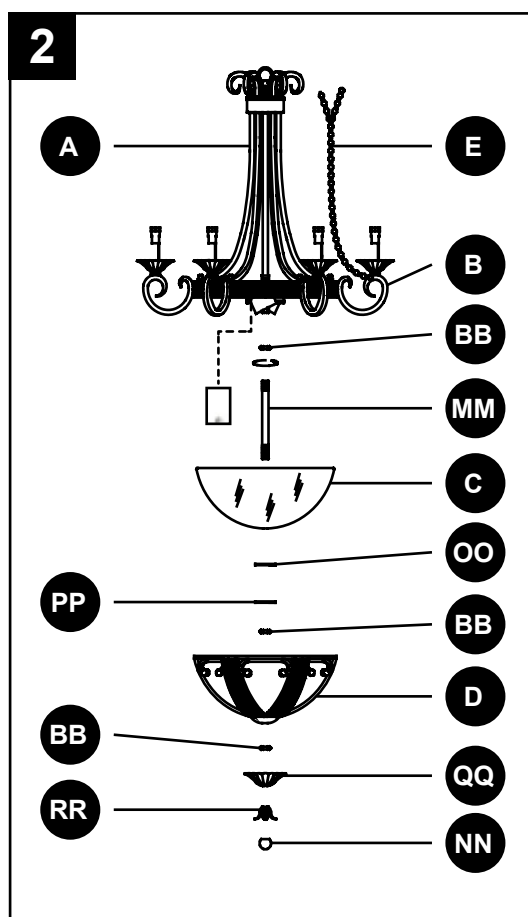
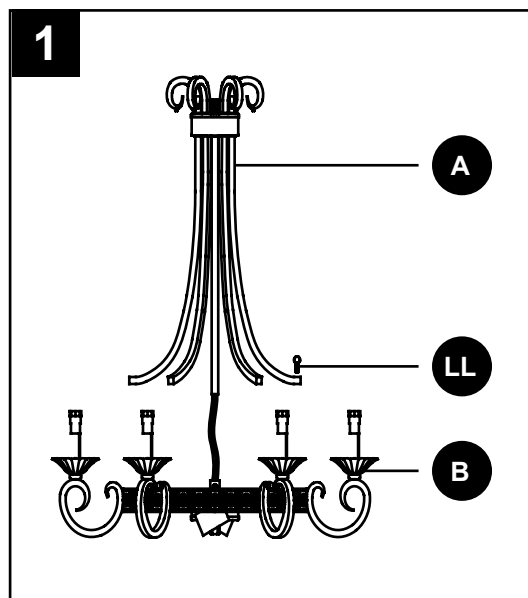

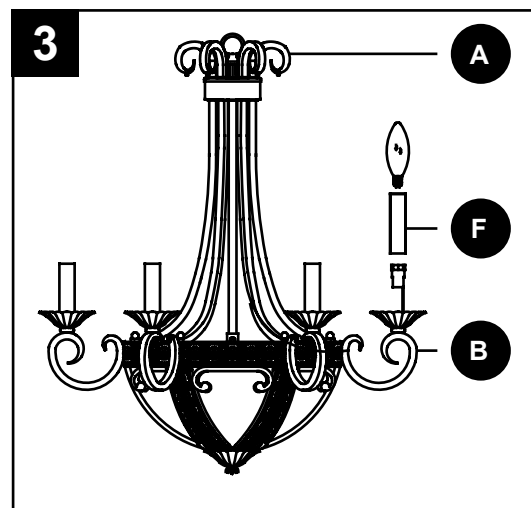

ASSEMBLY INSTRUCTIONS

- Install candle covers (F) over sockets of fixture body (B). Install six 60-watt max. E12 candelabra-base bulbs (not included).



- Secure the crossbar (CC) onto the outlet box (not included) with outlet box screws (AA). Tighten until snug.

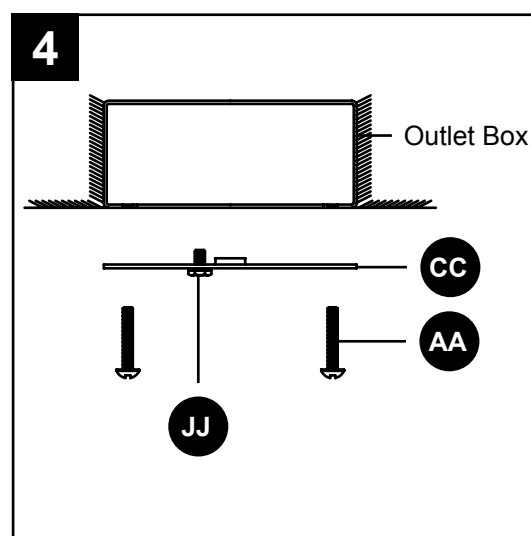

HARDWARE USED

AA	Outlet Box Screw		x 2
CC	Crossbar		x 1



- Thread one hex nut (BB) onto top end of the mounting nipple (DD), then thread the mounting nipple (DD) into the center lock hole of the crossbar (CC). Using pliers (not included), secure hex nut (BB) against the crossbar (CC). Thread another hex nut (BB) onto the bottom end of the mounting nipple (DD).

HARDWARE USED

BB	Hex Nut		x 2
DD	Mounting Nipple		x 1

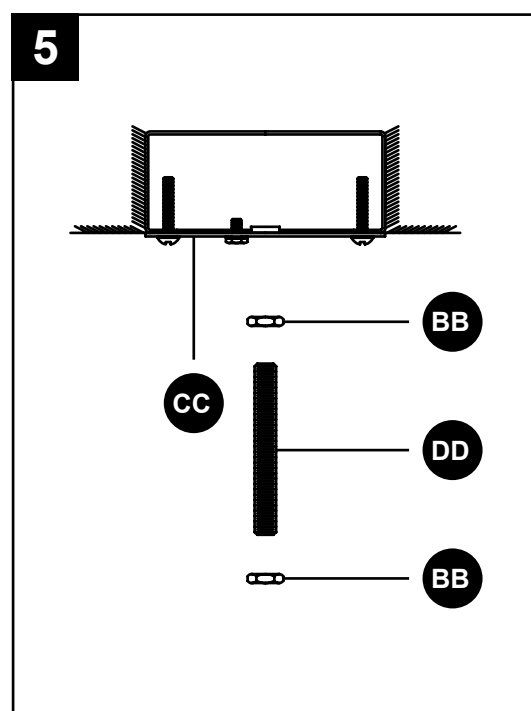





ASSEMBLY INSTRUCTIONS

6. Remove collar loop ring (KK) from collar loop (GG). Turn collar loop (GG) onto mounting nipple (DD) and adjust the hex nut (BB) so it attaches to the collar loop (GG).

Pull the supply wires through the chain (HH), alternating links, then pull the wires through the collar loop ring (KK), canopy (FF), collar loop (GG) and then mounting nipple (DD).

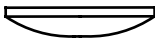
Attach chain (HH) to collar loop (GG) with preassembled link (II), then attach chain (HH) to fixture loop on arm (A) with chain link (II).

HARDWARE USED

FF	Canopy		x	1
GG	Collar Loop		x	1
HH	Chain		x	1
II	Chain Link		x	2
KK	Collar Loop Ring		x	1

7. Attach ground fixture wire to either green ground screw (JJ) on crossbar (CC) or the ground wire in the outlet box (usually GREEN or BARE). If attaching to ground wire in the outlet box, fasten together with a wire connector (EE) and tight l y wrap with electrical tape (not included).

IT IS IMPORTANT THE OUTLET BOX IN YOUR HOME IS PROPERLY GROUNDED.

Connect the neutral (WHITE or IDENTIFIED side) fixture wire to the neutral (usually WHITE) wire from the outlet box. Fasten wires together with a wire connector (EE) and tightly wrap wire connector (EE) with electrical tape. Connect the hot (BLACK or PLAIN side) fixture wire to the hot (usually BLACK) wire from the outlet box. Fasten wires together with a wire connector (EE) and tightly wrap wire connector (EE) with electrical tape. Connect the hot (BLACK or PLAIN side) fixture wire to the hot (usually BLACK) wire from the outlet box. Fasten wires together with a wire connector (EE) and tightly wrap wire connector (EE) with electrical tape.

HARDWARE USED

EE	Wire Connector		x	3
-----------	----------------	---	---	---

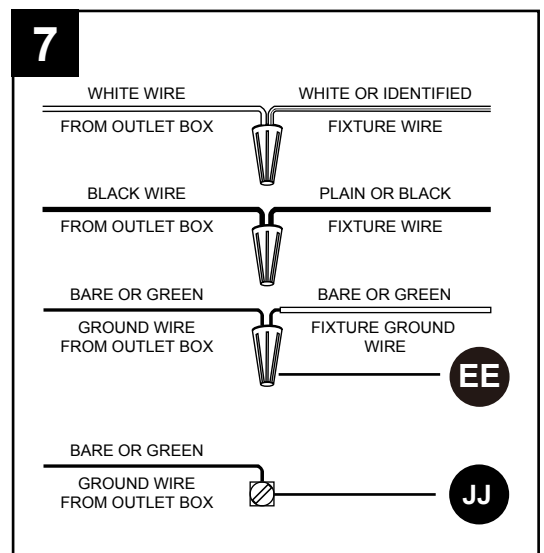
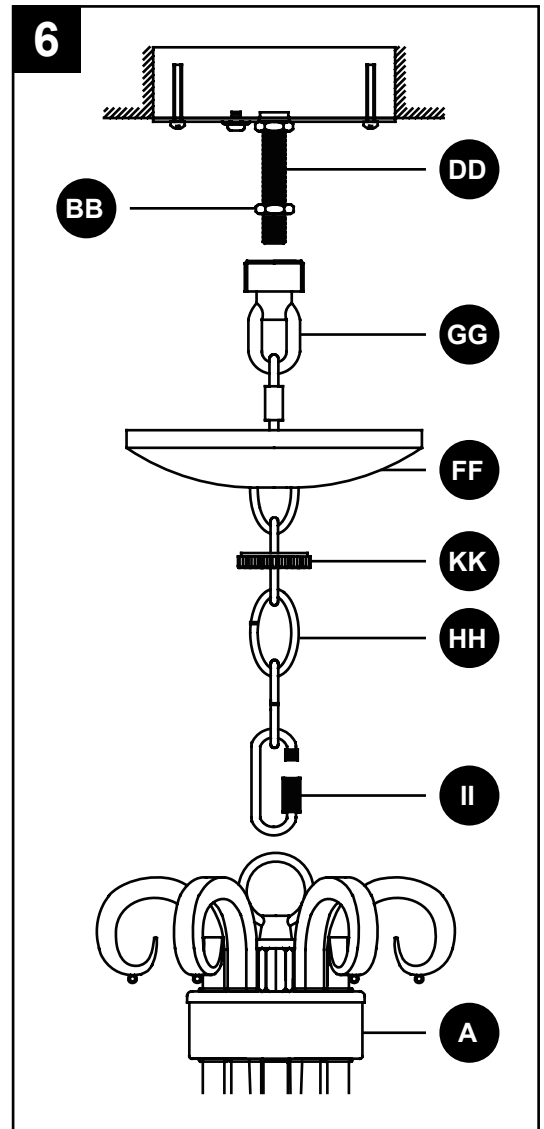

ASSEMBLY INSTRUCTIONS

8. Push the canopy (FF) upward to the outlet box. Thread the collar loop ring (KK) onto the collar loop (GG) and tighten until snug to secure canopy (FF).

HARDWARE USED

FF	Canopy		x	1
GG	Collar Loop		x	1
KK	Collar Loop Ring		x	1

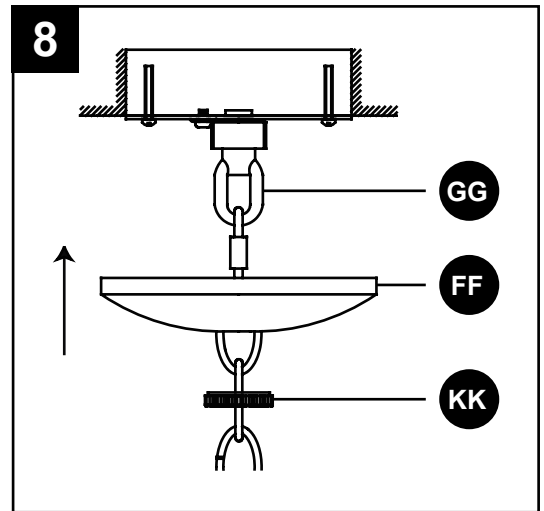

CARE AND MAINTENANCE

- Wipe clean using soft, dry cloth or static duster. Always avoid using harsh chemicals and abrasives to clean fixture as they may damage the finish.

TROUBLESHOOTING

PROBLEM	POSSIBLE CAUSE	CORRECTIVE ACTION
Bulbs will not light	<ol style="list-style-type: none"> 1. Bulb is burned out. 2. Power is off 3. Faulty wire connection. 4. Faulty switch. 	<ol style="list-style-type: none"> 1. Replace light bulb. 2. Make sure power supply is on. 3. Check wiring. 4. Test or replace the switch.
Fuse blows or the circuit breaker trips when light is turned on.	Crossed wires or power wire is grounding out.	Check wire connection.

WARRANTY

The manufacturer warrants all of its lighting fixtures against defects in materials and workmanship for one (1) year from the date of purchase. If within this period the product is found to be defective in material or workmanship, the product must be returned, with a copy of the original sales receipt as proof of purchase, in the original carton, to the place of purchase. The manufacturer will, at its option, repair, replace or refund the original purchase price to the consumer. This warranty does not cover fixtures becoming defective due to misuse, accidental damage, improper handling and/or installation and specifically excludes liability for direct, incidental or consequential damages. As some states do not allow exclusions or limitations on an implied warranty, the above exclusions and limitations may not apply to you. This warranty gives you specific legal rights. You may have other rights that vary from state to state.

REPLACEMENT PART LIST

For replacement parts, call our customer service department at 1-800-643-0067, 8 a.m. - 6 p.m., EST, Monday - Thursday, 8 a.m. - 5 p.m., EST, Friday.

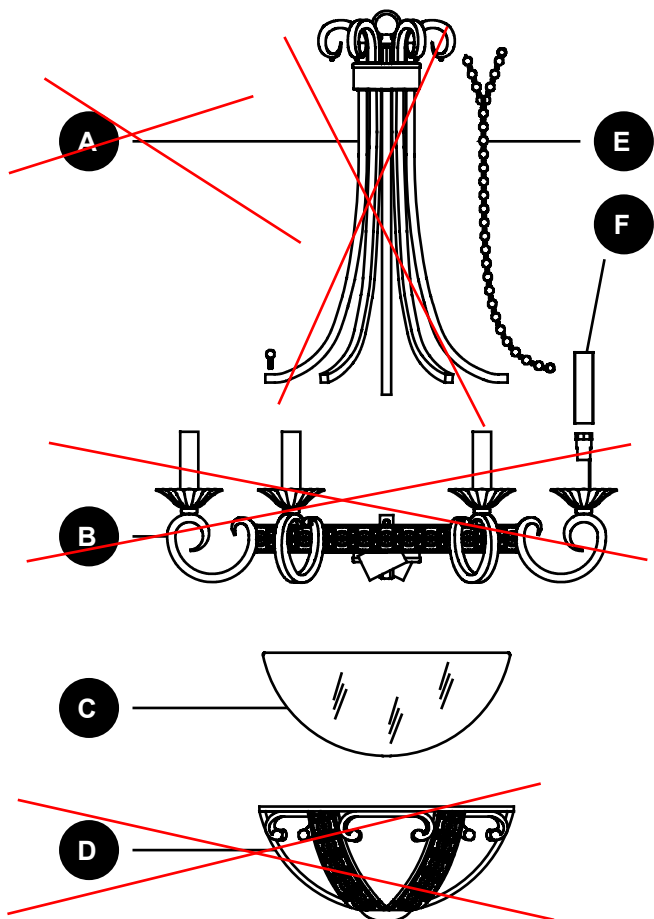

Part	Description	Part #
C	Shade	BE0367
E	Bead Chain	DB0193
F	Candle Cover	AF0020
AA	Outlet Box Screw	EK0032
BB	Hex Nut	EZ0001
CC	Crossbar	AG0029
DD	Mounting Nipple	EB0045
EE	Wire Connector	DF0021
FF	Canopy	AB0194
GG	Collar Loop	AD0020
HH	Chain	AZ0003
II	Chain Link	AZ0003-1
JJ	Green Ground Screw	EZ0071
KK	Collar Loop Ring	AD0020-1
LL	Ball Nut With Stud	AC0057
MM	Nipple	ED0130
NN	Ball Nut	AC0041
OO	Rubber Washer	DF0008
PP	Spacer	EZ0017
QQ	Flower Cup	AB0342
RR	Decorative Flower	AZ0521

REPLACEMENT PART LIST

For replacement parts, call our customer service department at 1-800-643-0067, 8 a.m. - 6 p.m., EST, Monday - Thursday, 8 a.m. - 5 p.m., EST, Friday.

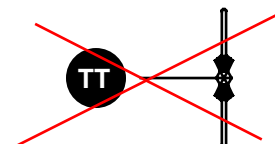
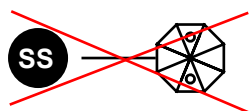
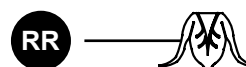
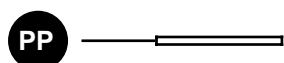
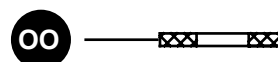
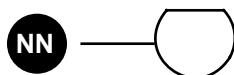
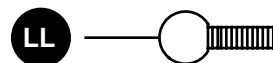
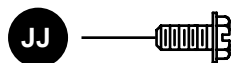
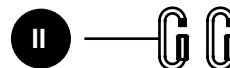
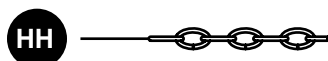
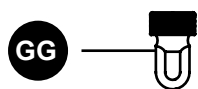
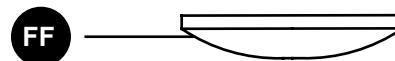
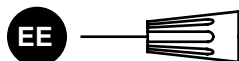
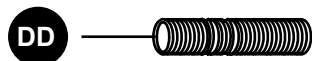
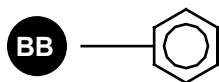
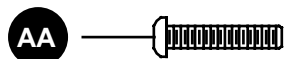

PORTFOLIO®

Portfolio® est une marque de commerce déposée de LF, LLC.
Tous droits réservés.

ARTICLE #0388009

LUSTRE À HUIT LUMIÈRES

MODÈLE #23384-026

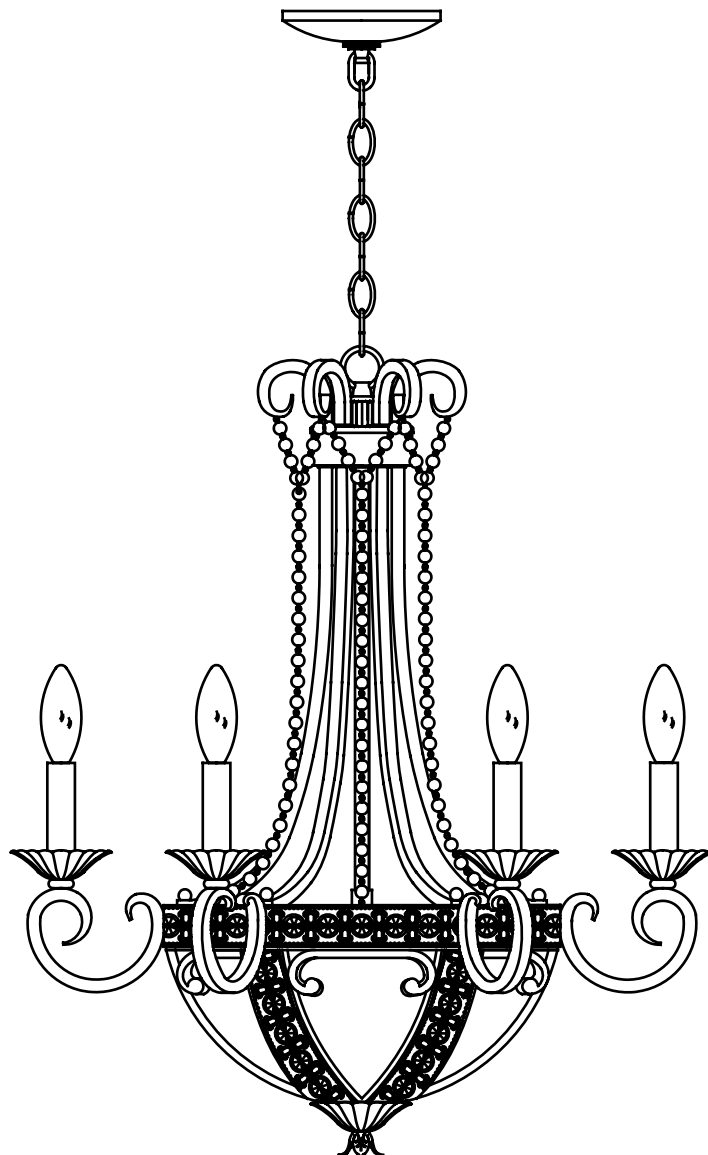

JOIGNEZ VOTRE REÇU ICI

Numéro de série _____ Date d'achat _____



Des questions, des problèmes, des pièces manquantes? Avant de retourner l'article au détaillant, appelez notre service à la clientèle au 1 800 643-0067, entre 8 h et 18 h (HNE), du lundi au jeudi, ou entre 8 h et 17 h (HNE) le vendredi.

CONTENU DE L'EMBALLAGE

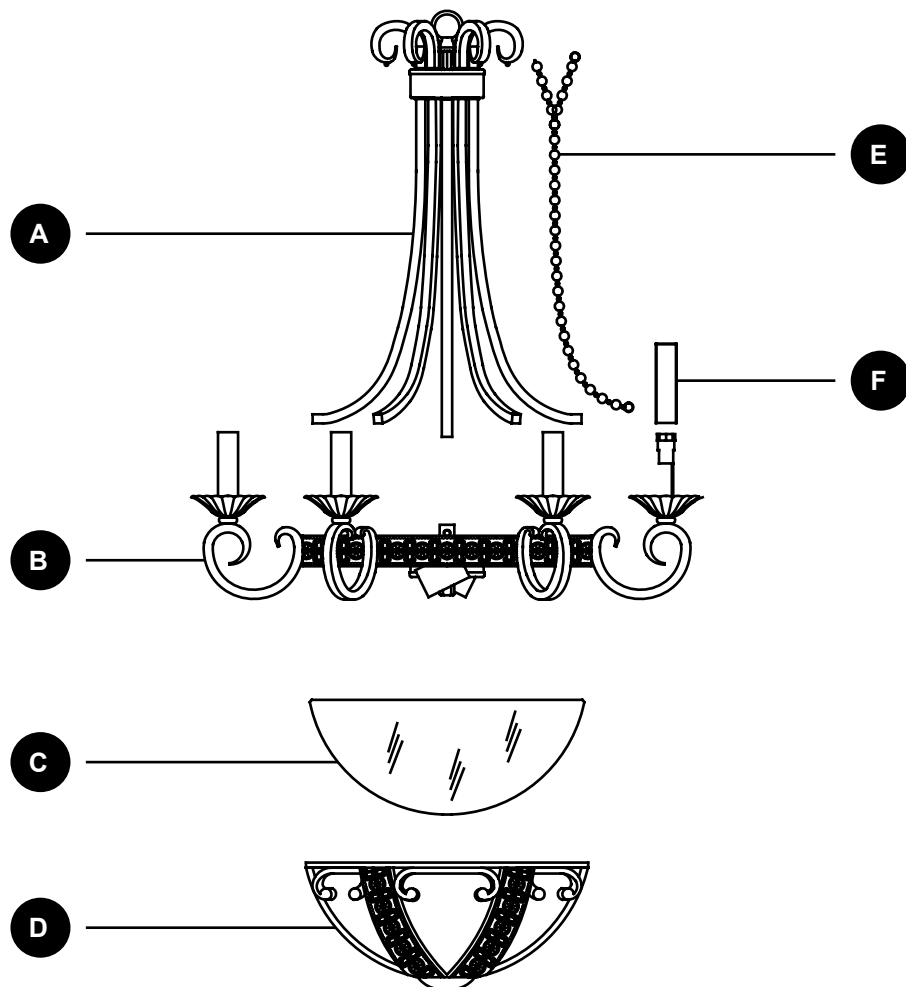

PIÈCE	DESCRIPTION	QUANTITÉ
A	Bras	6
B	Corps du luminaire	1
C	Abat-jour	1
D	Cadre décoratif	6
E	Chaîne de perles	6
F	Manchon	6

QUINCAILLERIE INCLUSE (grandeur réelle)

AA

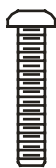

Vis pour boîte de sortie
Qté : 2

BB

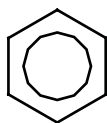

Écrou hexagonal
Qté : 5

CC



Traverse
(Grandeur non réelle)
Qté : 1

DD



Tige filetée de montage
(Grandeur non réelle)
Qté : 1

EE

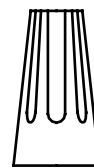

Capuchon de connexion
Qté : 3

FF

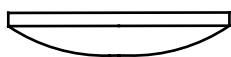

Couvercle
(Grandeur non réelle)
Qté : 1

GG

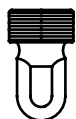

Anneau de fixation
(Grandeur non réelle)
Qté : 1

HH



Chaîne
(Grandeur non réelle)
Qté : 1

II



Maillon de chaîne
(Grandeur non réelle)
Qté : 2

JJ



Vis de mise à la terre verte (préassemblée à la traverse [CC])
(Grandeur non réelle)
Qté : 1

KK



Bague d'anneau de fixation (préassemblée à la traverse [CC])
Qté : 1

LL



Écrou sphérique avec goujon
Qté : 6

MM



Tige filetée
Qté : 1

NN



Écrou sphérique
Qté : 1

OO



Rondelle en caoutchouc
Qté : 1

PP



Entretoise
Qté : 1

QQ

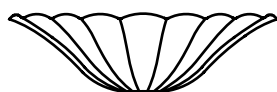

Coupelle à fleur
Qté : 1

RR



Fleur décorative
Qté : 1

CONSIGNES DE SÉCURITÉ

Assurez-vous de lire et de comprendre l'intégralité du présent manuel avant de tenter d'assembler, d'installer ou d'utiliser l'article.

AVERTISSEMENT

- **RISQUE DE CHOC ÉLECTRIQUE** – Avant de commencer l'installation, coupez l'alimentation électrique en plaçant le disjoncteur en position hors tension ou en retirant le fusible.
- **RISQUE D'INCENDIE** – N'utilisez que des ampoules correspondant aux spécifications inscrites sur l'étiquette du luminaire.

MISE EN GARDE

- Par mesure de sécurité, lisez toutes les instructions avant de procéder à l'installation.
- Faites appel à un électricien qualifié si vous n'êtes pas certain de la marche à suivre pour l'installation.
- Éteignez le luminaire avant de remplacer une ampoule.

PRÉPARATION

Avant de commencer l'assemblage du produit, assurez-vous d'avoir toutes les pièces. Comparez les pièces dans l'emballage avec la liste et le tableau ci-dessus. S'il y a des pièces manquantes ou endommagées, ne tentez pas d'assembler l'article. Communiquez avec notre service à la clientèle pour obtenir des pièces de rechange.

Temps d'assemblage approximatif : de 25 à 30 minutes

Outils nécessaires pour l'assemblage (non inclus) : tournevis à tête plate, tournevis cruciforme, pinces, ruban isolant, coupe-fil, six ampoules à petit culot d'un maximum de 60 W et deux ampoules à culot A19 d'un maximum de 60 W.

Outils utiles (non inclus) : pinces à dénuder et escabeau

INSTRUCTIONS POUR L'ASSEMBLAGE

1. Raccordez les bras (A) et le corps du luminaire (B) à l'aide des écrous sphériques avec goujon (LL).

Quincaillerie utilisée

LL	Écrou sphérique avec goujon		x 6
-----------	-----------------------------	---	-----

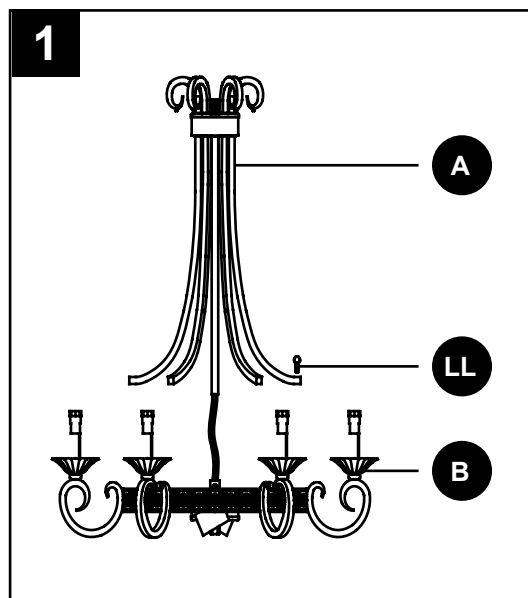







2. Raccordez les chaînes de perles (E) aux bras (A) et au corps du luminaire (B).

Vissez l'écrou hexagonal (BB) à la tige filetée (MM), puis raccordez-le à l'écrou d'accouplement du corps du luminaire (B). Posez l'abat-jour (C), la rondelle en caoutchouc (OO) et l'entretoise (PP) sur la tige filetée (MM), puis fixez le tout à l'aide de l'écrou hexagonal (BB). Insérez deux ampoules à culot moyen A19 d'un maximum de 60 W (non incluses) dans le corps du luminaire (B).

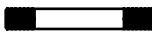
Faites passer la tige filetée (MM) à travers le trou central de l'armature décorative (D), puis fixez le tout à l'aide d'un écrou hexagonal (BB).

Posez la coupelle à fleur (QQ) et la fleur décorative (RR) sur la tige filetée (MM), puis fixez le tout à l'aide de l'écrou sphérique (NN).

Quincaillerie utilisée

BB	Écrou hexagonal		x 3
MM	Tige filetée		x 1
NN	Écrou sphérique		x 1
OO	Rondelle en caoutchouc		x 1
PP	Entretoise		x 1
QQ	Coupelle à fleur		x 1
RR	Fleur décorative		x 1

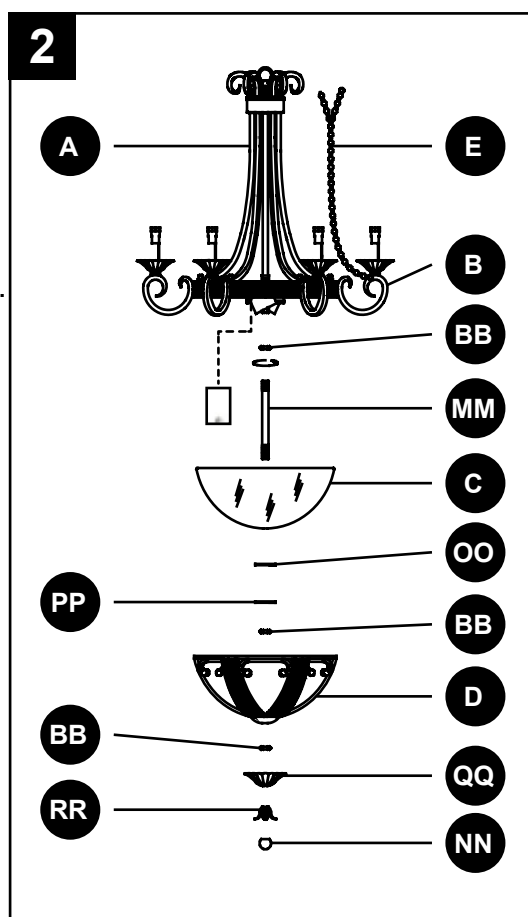

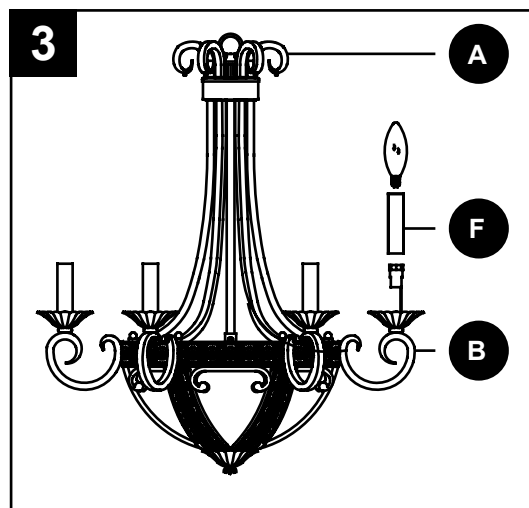

INSTRUCTIONS POUR L'ASSEMBLAGE

3. Posez les manchons (F) sur les douilles du corps du luminaire (B). Insérez six ampoules à petit culot E12 d'un maximum de 60 W (non incluses).



4. Fixez la traverse (CC) à la boîte de sortie (non incluse) à l'aide des vis de boîte de sortie (AA). Serrez fermement.

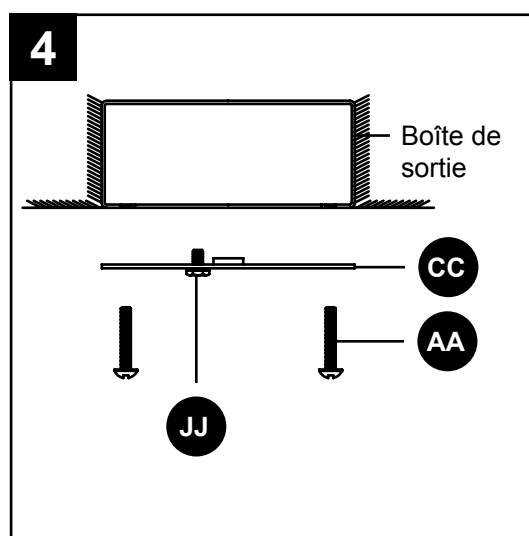

Quincaillerie utilisée

AA	Vis pour boîte de sortie		x 2
CC	Traverse		x 1



5. Vissez un écrou hexagonal (BB) à l'extrémité supérieure de la tige filetée de montage (DD), puis vissez la tige filetée de montage (DD) dans le trou de verrouillage central de la traverse (CC). Fixez l'écrou hexagonal (BB) à la traverse (CC) à l'aide de pinces (non incluses). Vissez un autre écrou hexagonal (BB) à l'extrémité inférieure de la tige filetée (DD).

Quincaillerie utilisée

BB	Écrou hexagonal		x 2
DD	Tige filetée de montage		x 1

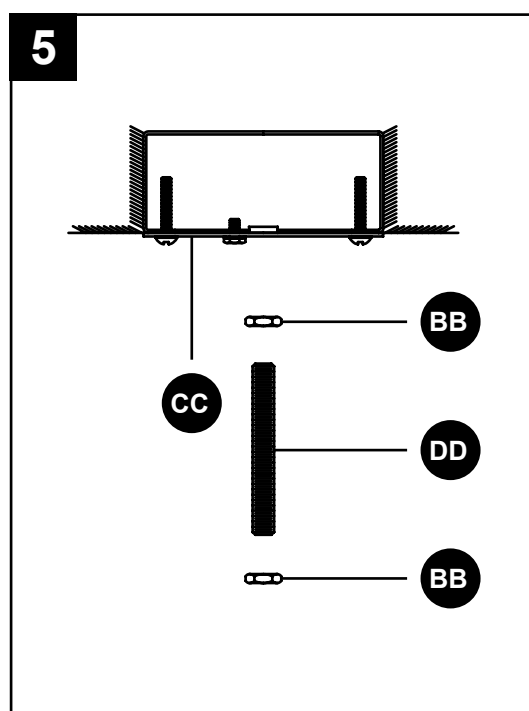





INSTRUCTIONS POUR L'ASSEMBLAGE

6. Retirez la bague d'anneau de fixation (KK) de l'anneau de fixation (GG). Posez l'anneau de fixation (GG) sur la tige filetée de montage (DD) et ajustez l'écrou hexagonal (BB) de façon à ce qu'il se fixe à l'anneau de fixation (GG).

Tirez les fils d'alimentation à travers les maillons de la chaîne (HH), en alternance, puis tirez les fils à travers la bague d'anneau de fixation (KK), le couvercle (FF), l'anneau de fixation (GG) et la tige filetée de montage (DD).

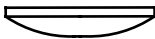
Fixez la chaîne (HH) au maillon préassemblé de l'anneau de fixation (GG), puis fixez la chaîne (HH) à l'anneau de suspension du bras (A) à l'aide du maillon de chaîne (II).

Quincaillerie utilisée

FF	Couvercle		x 1
GG	Anneau de fixation		x 1
HH	Chaîne		x 1
II	Maillon de chaîne		x 2
KK	Bague d'anneau de fixation		x 1

7. Fixez le fil de mise à la terre à la vis de mise à la terre verte (JJ) de la traverse (CC) ou joignez-le au fil de mise à la terre de la boîte de sortie (fil habituellement VERT ou DÉNUDÉ). Si vous choisissez la deuxième option, joignez les deux fils au moyen d'un capuchon de connexion (EE) et enrroulez-les avec du ruban isolant (non inclus) bien serré.

IL EST IMPORTANT QUE LA BOÎTE DE SORTIE DE VOTRE MAISON SOIT CORRECTEMENT MISE À LA TERRE.

Raccordez le fil neutre du luminaire (BLANC ou MARQUÉ sur le côté) au fil neutre (généralement BLANC) de la boîte de sortie. Joignez les deux fils au moyen d'un capuchon de connexion (EE), et couvrez le capuchon de ruban isolant en serrant bien. Connectez le fil chargé du luminaire (NOIR ou NON MARQUÉ sur le côté) au fil chargé (généralement NOIR) de la boîte de sortie. Joignez les deux fils au moyen d'un capuchon de connexion (EE), et couvrez le capuchon de ruban isolant en serrant bien.

Quincaillerie utilisée

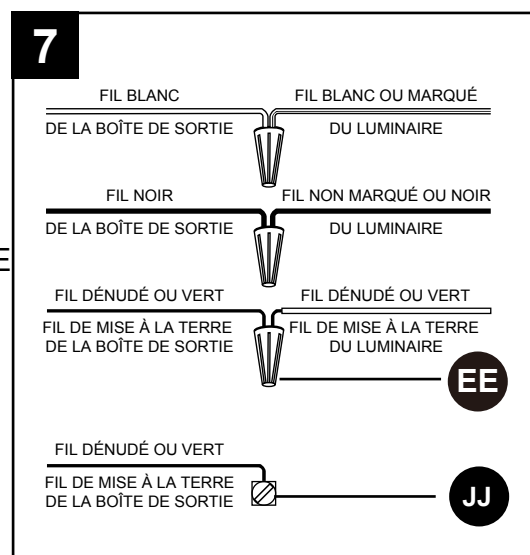
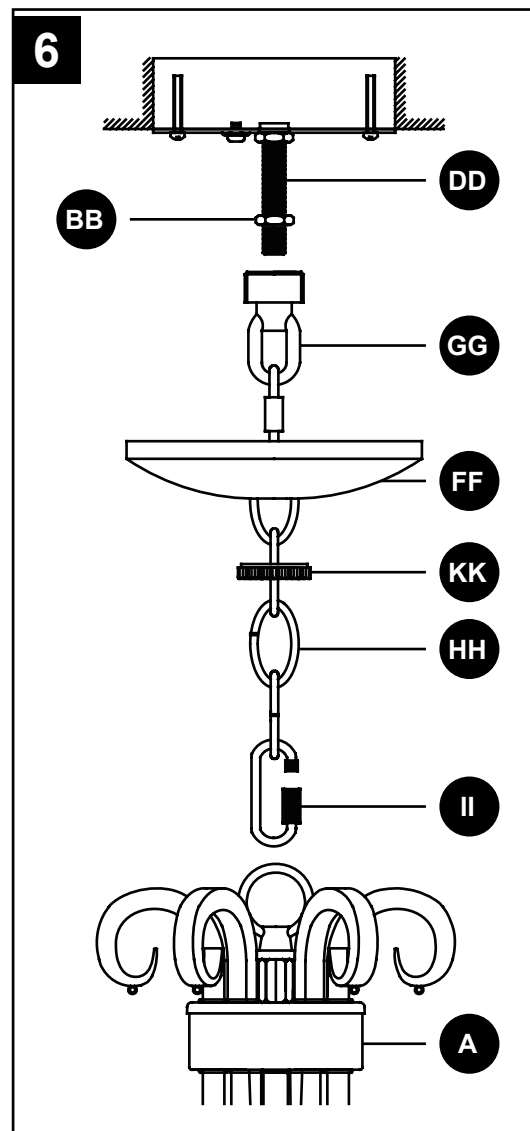

EE	Capuchon de connexion		x 3
-----------	-----------------------	---	-----



INSTRUCTIONS POUR L'ASSEMBLAGE

8. Poussez le couvercle (FF) sur la boîte de sortie. Vissez la bague d'anneau de fixation (KK) à l'anneau de fixation (GG), puis serrez-la fermement de façon à fixer le couvercle (FF).

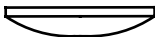
Quincaillerie utilisée

FF	Couvercle		x	1
GG	Anneau de fixation		x	1
KK	Bague d'anneau de fixation		x	1

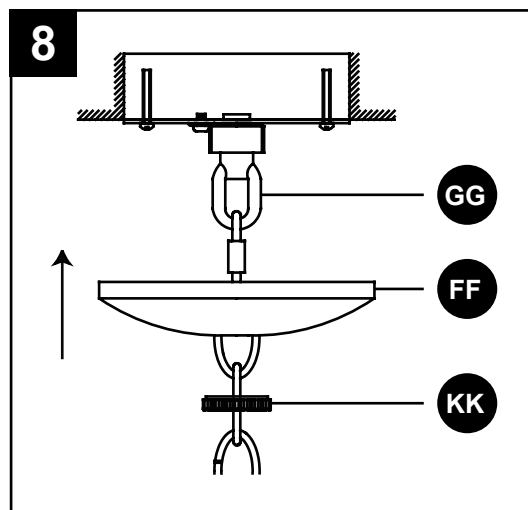

ENTRETIEN

- Nettoyez l'article à l'aide d'un linge doux et sec ou d'un plumeau. Évitez les produits chimiques forts et les nettoyeurs abrasifs; ils pourraient endommager le fini.

DÉPANNAGE

PROBLÈME	CAUSE POSSIBLE	MESURE CORRECTIVE
Une ampoule ne s'allume pas.	<ol style="list-style-type: none">L'ampoule est grillée.L'alimentation est coupée.Les fils électriques sont mal branchés.L'interrupteur est défectueux.	<ol style="list-style-type: none">Remplacez l'ampoule.Vérifiez l'alimentation électrique.Vérifiez le câblage.Testez ou remplacez l'interrupteur.
Un fusible saute ou un disjoncteur se déclenche lorsque le luminaire est mis sous tension.	Des fils sont croisés ou il n'y a pas de mise à la terre.	Vérifiez les connexions.

GARANTIE

Le fabricant garantit tous ses luminaires contre les défauts de matériaux ou de fabrication pour une période de un (1) an à compter de la date d'achat. Si, durant cette période, l'article présente des défauts de matériaux ou de fabrication, retournez-le au détaillant dans sa boîte d'origine, accompagné du reçu. Le fabricant choisira de réparer ou de remplacer le produit, ou de rembourser l'équivalent du prix d'achat. Cette garantie ne s'applique pas aux défauts causés par un usage inapproprié, des dommages accidentels, une manipulation ou une installation inadéquate, et elle exclut expressément toute responsabilité pour des dommages directs, accidentels ou consécutifs. Certains États ou certaines provinces ne permettent pas l'exclusion ou la limitation d'une garantie implicite, de sorte que les limitations et exclusions mentionnées ci-dessus peuvent ne pas s'appliquer à vous. Cette garantie vous confère des droits précis. Il est possible que vous disposiez également d'autres droits, qui varient d'un État ou d'une province à l'autre.

LISTE DES PIÈCES DE RECHANGE

Pour obtenir des pièces de rechange, communiquez avec notre service à la clientèle au 1 800 643-0067, entre 8 h et 18 h (HNE), du lundi au jeudi, ou entre 8 h et 17 h (HNE) le vendredi.

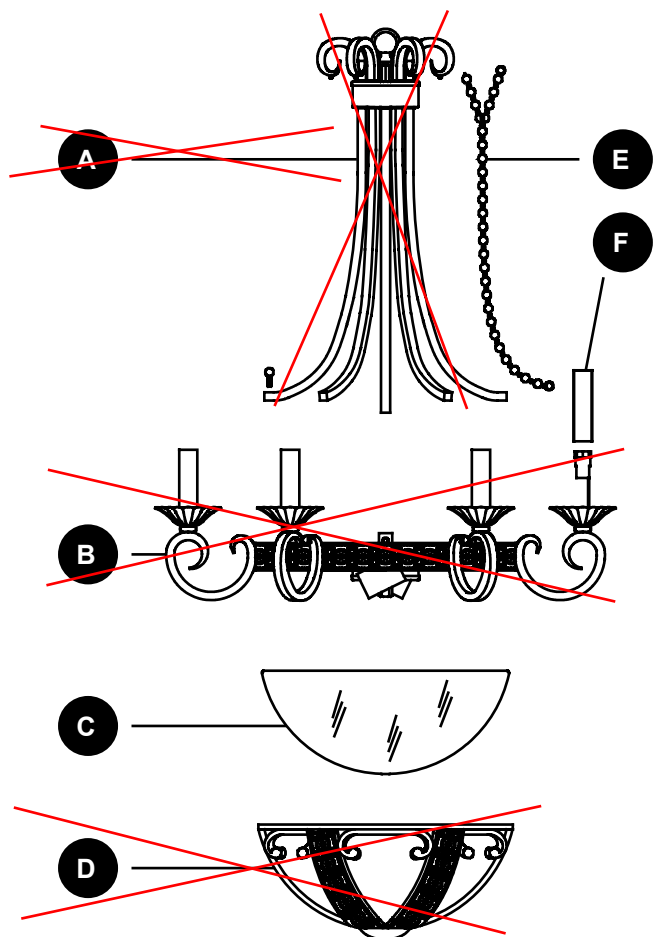

PIÈCE	DESCRIPTION	NO DE PIÈCE
C	Abat-jour	BE0367
E	Chaîne de perles	DB0193
F	Manchon	AF0020
AA	Vis pour boîte de sortie	EK0032
BB	Écrou hexagonal	EZ0001
CC	Traverse	AG0029
DD	Tige filetée de montage	EB0045
EE	Capuchon de connexion	DF0021
FF	Couvercle	AB0194
GG	Anneau de fixation	AD0020
HH	Chaîne	AZ0003
II	Maillon de chaîne	AZ0003-1
JJ	Vis de mise à la terre verte	EZ0071
KK	Bague d'anneau de fixation	AD0020-1
LL	Écrou sphérique avec goujon	AC0057
MM	Tige filetée	ED0130
NN	Écrou sphérique	AC0041
OO	Rondelle en caoutchouc	DF0008
PP	Entretoise	EZ0017
QQ	Coupelle à fleur	AB0342
RR	Fleur décorative	AZ0521

LISTE DES PIÈCES DE RECHANGE

Pour obtenir des pièces de rechange, communiquez avec notre service à la clientèle au 1 800 643-0067, entre 8 h et 18 h (HNE), du lundi au jeudi, ou entre 8 h et 17 h (HNE) le vendredi.

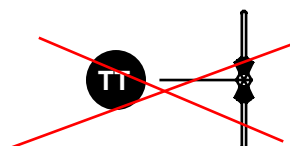
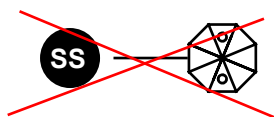
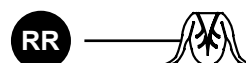
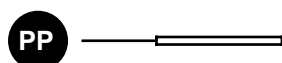
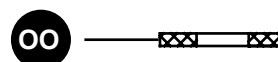
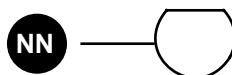
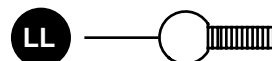
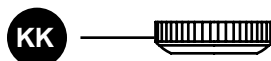
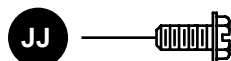
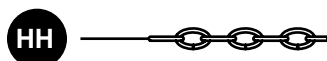
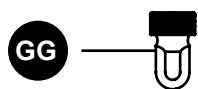
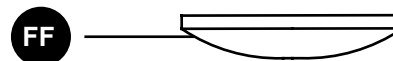
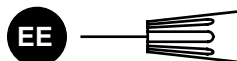
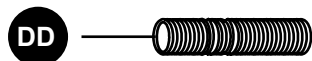
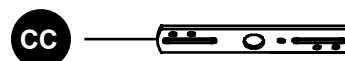
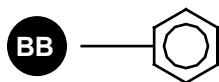
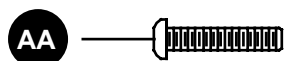

PORTFOLIO®

Portfolio® es una marca registrada de LF, LLC. Todos los derechos reservados.

ARTÍCULO #0388009

CANDELABRO DE 8 LUCES

MODELO #23384-026

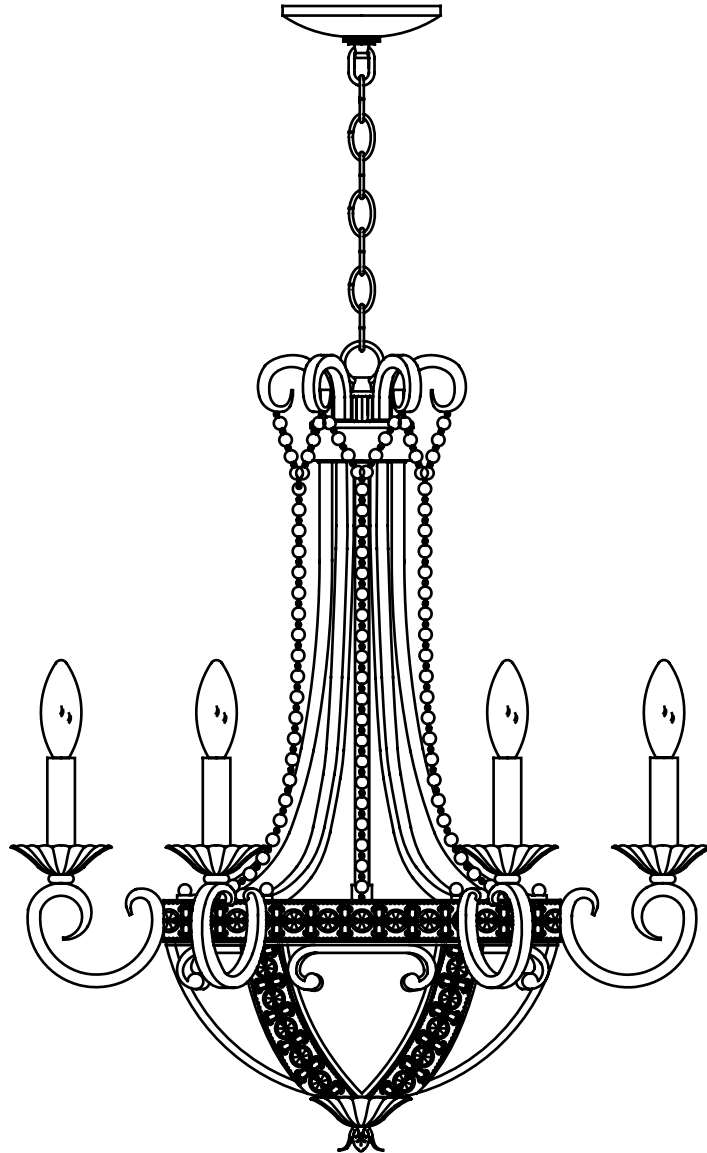

ADJUNTE SU RECIBO AQUÍ

Número de serie _____ Fecha de compra _____



¿Preguntas, problemas, piezas faltantes? Antes de volver a la tienda, llame a nuestro Departamento de Servicio al Cliente al 1-800-643-0067, de lunes a jueves de 8 a.m. a 6 p.m., y los viernes de 8 a.m. a 5 p.m., hora estándar del Este.

CONTENIDO DEL PAQUETE

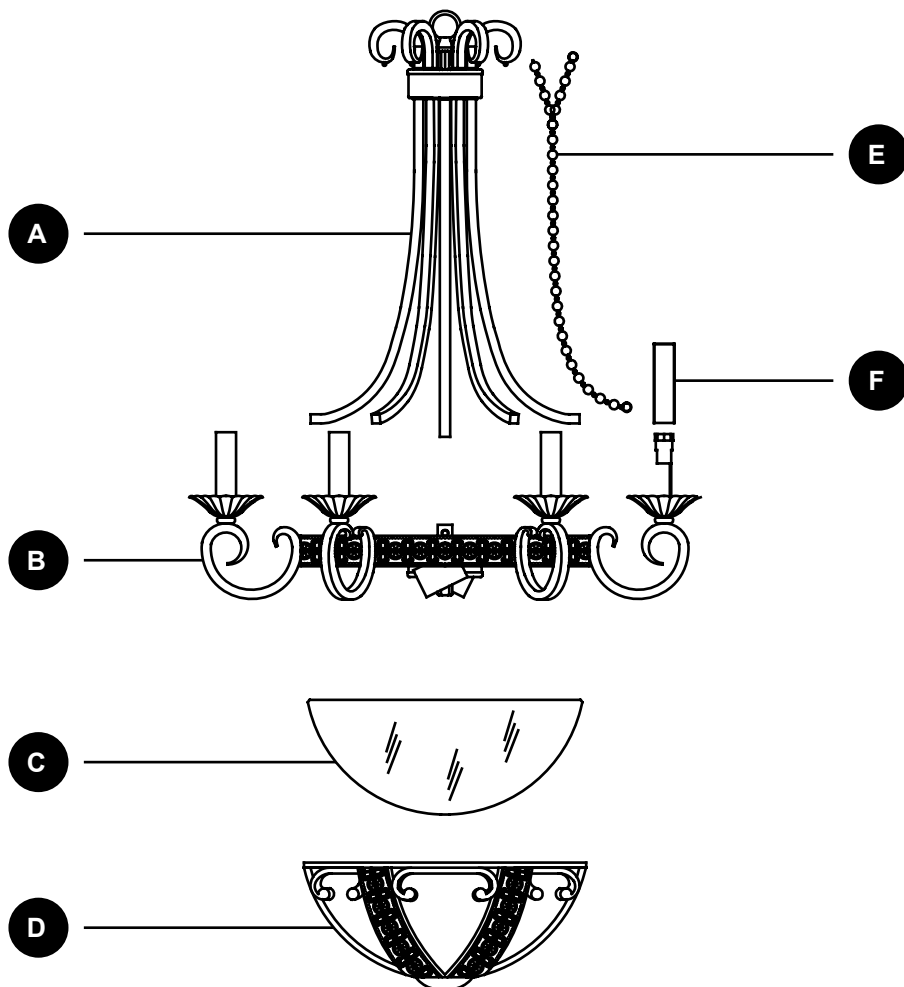

PIEZA	DESCRIPCIÓN	CANTIDAD
A	Brazo	6
B	Cuerpo de la lámpara	1
C	Pantalla	1
D	Marco decorativo	6
E	Cadena con reborde	6
F	Casquillo	6

ADITAMENTOS (se muestran en tamaño real)

AA



Tornillo para la
caja de salida
Cant. 2

BB

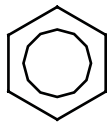

Tuerca hexagonal
Cant. 5

CC



Placa perforada
(no se muestra en
tamaño real)
Cant. 1

DD



Manguito roscado
de montaje
(no se muestra en
tamaño real)
Cant. 1

EE



Conector de
cables
Cant. 3

FF

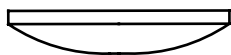

Cubierta
(no se muestra en
tamaño real)
Cant. 1

GG

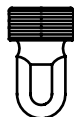

Enganche del
anillo
(no se muestra en
tamaño real)
Cant. 1

HH



Cadena
(no se muestra en
tamaño real)
Cant. 1

II



Eslabón con
seguro giratorio
(no se muestra en
tamaño real)
Cant. 2

JJ



Tornillo verde de puesta
a tierra (preassembled
to Placa perforada
(CC)) (no se muestra en
tamaño real)
Cant. 1

KK



Aro de enganche
del anillo
(preassembled to
Placa perforada
(CC))
Cant. 1

LL



Tuerca esférica
con montante
Cant. 6

MM



Manguito roscado
Cant. 1

NN



Tuerca esférica
Cant. 1

OO



Arandela de goma
Cant. 1

PP

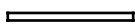

Espaciador
Cant. 1

QQ

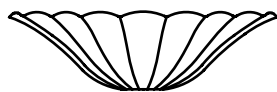

Base con forma
de flor
Cant. 1

RR



Flor decorativa
Cant. 1

INFORMACIÓN DE SEGURIDAD

Lea y comprenda completamente este manual antes de intentar ensamblar, usar o instalar el producto.

ADVERTENCIA

- **RIESGO DE DESCARGA ELÉCTRICA:** Antes de comenzar la instalación, coloque el interruptor de circuito en la posición de apagado o extraiga la caja de fusibles principal.
- **RIESGO DE INCENDIO:** Use las bombillas que se especifican en las marcas y/o las etiquetas en la lámpara.

PRECAUCIÓN

- Por su seguridad, lea completamente las instrucciones antes de comenzar la instalación.
- Consulte con un electricista calificado si tiene dudas sobre la instalación eléctrica.
- Desconecte la alimentación eléctrica a la lámpara antes de reemplazar las bombillas.

PREPARACIÓN

Antes de comenzar a ensamblar el producto, asegúrese de tener todas las piezas. Compare las piezas con la lista del contenido del paquete y el diagrama. No intente ensamblar el producto si falta alguna pieza o si estas están dañadas. Póngase en contacto con el Departamento de Servicio al Cliente para obtener piezas de repuesto.

Tiempo estimado de ensamblaje: 25 a 30 minutos.

Herramientas necesarias para el ensamblaje (no se incluyen): Destornillador de cabeza plana, destornillador Phillips, pinzas, cinta aislante, pinzas cortacables, seis bombillas de base candelabro de 60 vatios como máximo y dos bombillas de base A19 de 60 vatios como máximo.

Herramientas útiles (no se incluyen): Pinzas pelacables, escalera

INSTRUCCIONES DE ENSAMBLAJE

1. Conecte los brazos (A) y el cuerpo de la lámpara (B) por medio de las tuercas esféricas con montantes (LL).

Aditamentos utilizados

LL	Tuerca esférica con montante		x 6
-----------	------------------------------	---	-----

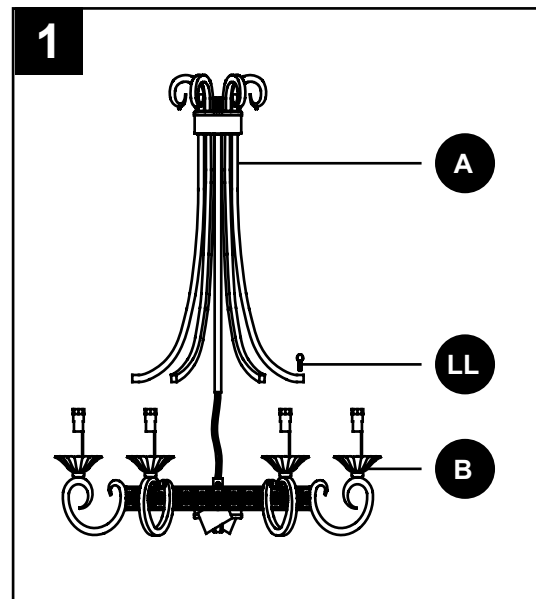

2. Conecte las cadenas con reborde (E) a los brazos (A) y al cuerpo de la lámpara (B).

Enrosque la tuerca hexagonal (BB) al manguito roscado (MM) y luego conéctela a la tuerca de acoplamiento en el cuerpo de la lámpara (B). Inserte la pantalla (C), la arandela de goma (OO) y el espaciador (PP) sobre el manguito roscado (MM) y luego asegúrelos con la tuerca hexagonal (BB). Instale dos bombillas de base mediana A19 de 60 vatios como máximo (no se incluyen) en el cuerpo de la lámpara (B).

Inserte el marco decorativo (D) en el manguito roscado (MM) a través del orificio central y asegúrelo con la tuerca hexagonal (BB).

Inserte la base con forma de flor (QQ) y la flor decorativa (RR) sobre el manguito roscado (MM) y asegúrelos con la tuerca esférica (NN).

Aditamentos utilizados

BB	Tuerca hexagonal		x 3
MM	Manguito roscado		x 1
NN	Tuerca esférica		x 1
OO	Arandela de goma		x 1
PP	Espaciador		x 1
QQ	Base con forma de flor		x 1
RR	Flor decorativa		x 1

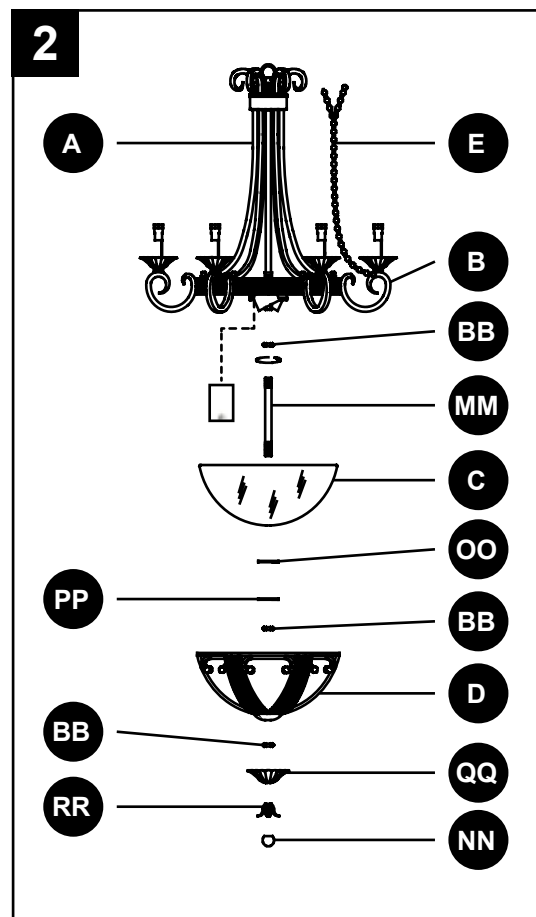

INSTRUCCIONES DE ENSAMBLAJE

3. Instale los casquillos (F) sobre los portalámparas del cuerpo de la lámpara (B). Instale seis bombillas de base candelabro E12 de 60 vatios como máximo (no se incluyen).

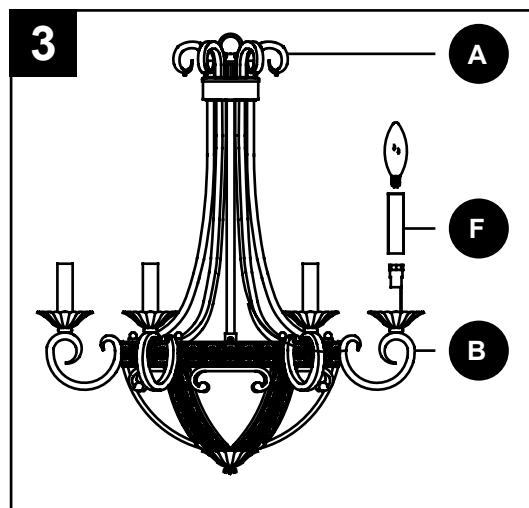

4. Fije la placa perforada (CC) a la caja de salida (no se incluye) con los tornillos para la caja de salida (AA). Apriete hasta que estén ajustados.

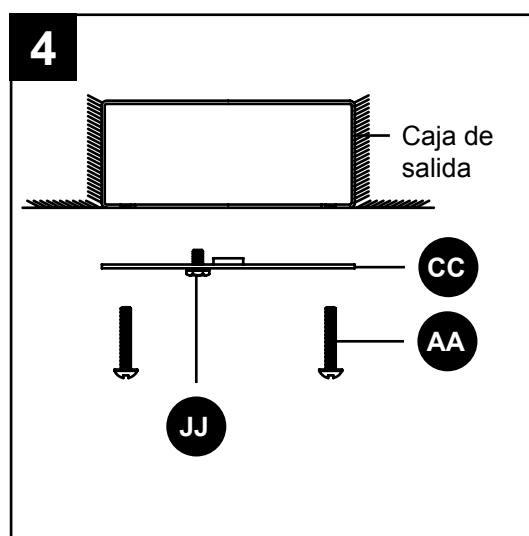

Aditamentos utilizados

AA	Tornillo para la caja de salida		x 2
CC	Placa perforada		x 1

5. Enrosque una tuerca hexagonal (BB) en el extremo superior del manguito roscado de montaje (DD), luego enrosque el manguito roscado de montaje (DD) en el orificio de bloqueo central de la placa perforada (CC). Con unas pinzas (no se incluyen), asegure la tuerca hexagonal (BB) contra la placa perforada (CC). Enrosque otra tuerca hexagonal (BB) en el extremo inferior del manguito roscado de montaje (DD).

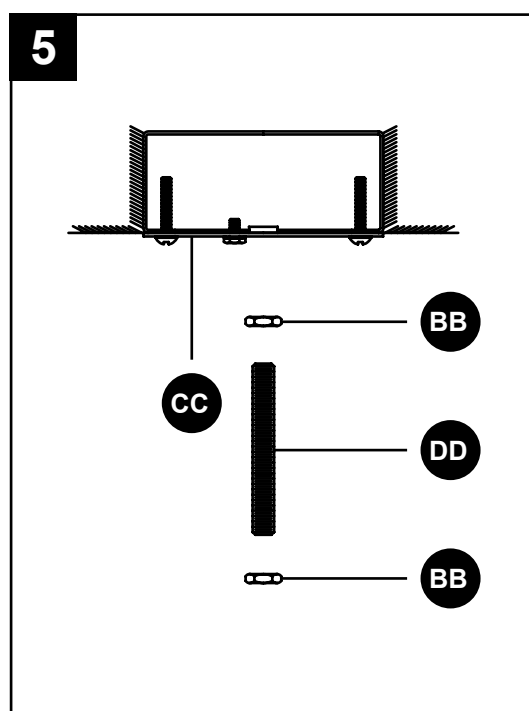

Aditamentos utilizados

BB	Tuerca hexagonal		x 2
DD	Manguito roscado de montaje		x 1





INSTRUCCIONES DE ENSAMBLAJE

6. Retire el aro de enganche del anillo (KK) del enganche del anillo (GG). Gire el enganche del anillo (GG) sobre el manguito roscado de montaje (DD) y ajuste la tuerca hexagonal (BB) para que se fije al enganche del anillo (GG).

Tire de los conductores a través de la cadena (HH), alternando los eslabones, tire de los cables a través del aro del enganche del anillo (KK), de la cubierta (FF), del enganche del anillo (GG) y luego a través del manguito roscado de montaje (DD).

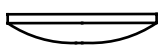
Fije la cadena (HH) al enganche del anillo (GG) con el eslabón preensamblado, luego fije la cadena (HH) al enganche de la lámpara en el brazo (A) con la malla ciclónica (II).

Aditamentos utilizados

FF	Cubierta		x 1
GG	Enganche del anillo		x 1
HH	Cadena		x 1
II	Cadena Link		x 2
KK	Aro de enganche del anillo		x 1

7. Fije el conductor de puesta a tierra de la lámpara al tornillo verde de puesta tierra (JJ) de la placa perforada (CC) o al conductor de puesta a tierra de la caja de salida (que generalmente es un conductor VERDE o DESNUDO). Si lo fija al conductor de puesta a tierra de la caja de salida, una ambos conductores con un conector de cables (EE) y envuélvalos firmemente con cinta aislante (no se incluye).

ES IMPORTANTE QUE LA CAJA DE SALIDA DE SU CASA TENGA UNA PUESTA A TIERRA ADECUADA.

Conecte el conductor neutro de la lámpara (BLANCO o IDENTIFICADO a los costados) al conductor neutro (generalmente BLANCO) de la caja de salida. Una los conductores con un conector de cables (EE) y envuelva firmemente dicho conector (EE) con cinta aislante. Conecte el conductor de corriente (NEGRO o LISO en los costados) de la lámpara al conductor de corriente (generalmente NEGRO) de la caja de salida. Una los conductores con un conector de cables (EE) y envuelva firmemente dicho conector (EE) con cinta aislante.

Aditamentos utilizados

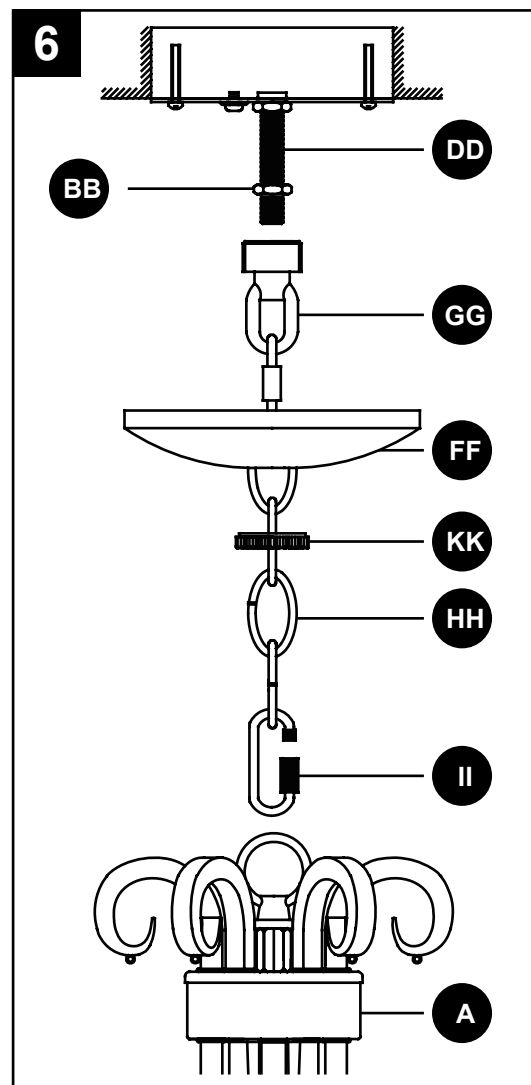

EE	Conector de cables		x 3
-----------	--------------------	---	-----



INSTRUCCIONES DE ENSAMBLAJE

8. Empuje la cubierta (FF) hacia arriba de la caja de salida. Enrosque el aro del enganche del anillo (KK) en el enganche del anillo (GG) y apriete hasta que quede fijo para asegurar la cubierta (FF).

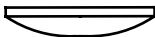
Aditamentos utilizados

FF	Cubierta		x	1
GG	Enganche del anillo		x	1
KK	Aro de enganche del anillo		x	1

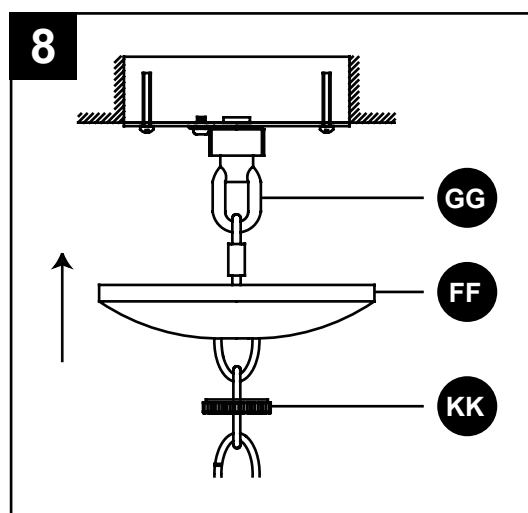

CUIDADO Y MANTENIMIENTO

- Limpie la lámpara con un paño suave y seco o con un paño de limpieza estático. No utilice productos químicos y limpiadores abrasivos ya que pueden dañar el acabado de la lámpara.

SOLUCIÓN DE PROBLEMAS

PROBLEMA	CAUSA POSIBLE	ACCIÓN CORRECTIVA
Las bombillas no encienden.	<ol style="list-style-type: none"> 1. La bombilla está quemada. 2. No hay alimentación. 3. La conexión de los cables es incorrecta. 4. El interruptor está defectuoso. 	<ol style="list-style-type: none"> 1. Reemplace la bombilla. 2. Compruebe si hay suministro de electricidad. 3. Revise el cableado. 4. Pruebe o reemplace el interruptor.
Cuando se enciende la luz, el fusible se quema o el interruptor de circuito se dispara.	Hay cables cruzados o el conductor de fuerza no tiene puesta a tierra.	Revise las conexiones del cableado.

GARANTÍA

El fabricante garantiza que todos sus ensamblajes de iluminación están libres de defectos en los materiales y la mano de obra por un (1) año a contar de la fecha de compra. Si dentro de este período el producto presenta defectos en los materiales o la mano de obra, se debe devolver el producto, junto con una copia del recibo de venta como prueba de la adquisición, en su caja original al lugar donde se compró. El fabricante, a su elección, reparará, reemplazará o reembolsará el monto original de la compra al comprador. Esta garantía no cubre lámparas dañadas debido al mal uso, daño accidental, manipulación y/o instalación inadecuadas y excluye específicamente toda responsabilidad por daños directos, accidentales o resultantes. Debido a que algunos estados no permiten exclusiones o limitaciones en una garantía implícita, las exclusiones y limitaciones anteriores pueden no aplicarse en su caso. Esta garantía le otorga derechos legales específicos. Usted podría tener otros derechos que varían según el estado.

LISTA DE PIEZAS DE REPUESTO

Para obtener piezas de repuesto, llame a nuestro Departamento de Servicio al Cliente al 1-800-643-0067, de lunes a jueves de 8 a.m. a 6 p.m., y los viernes de 8 a.m. a 5 p.m., hora estándar del Este.

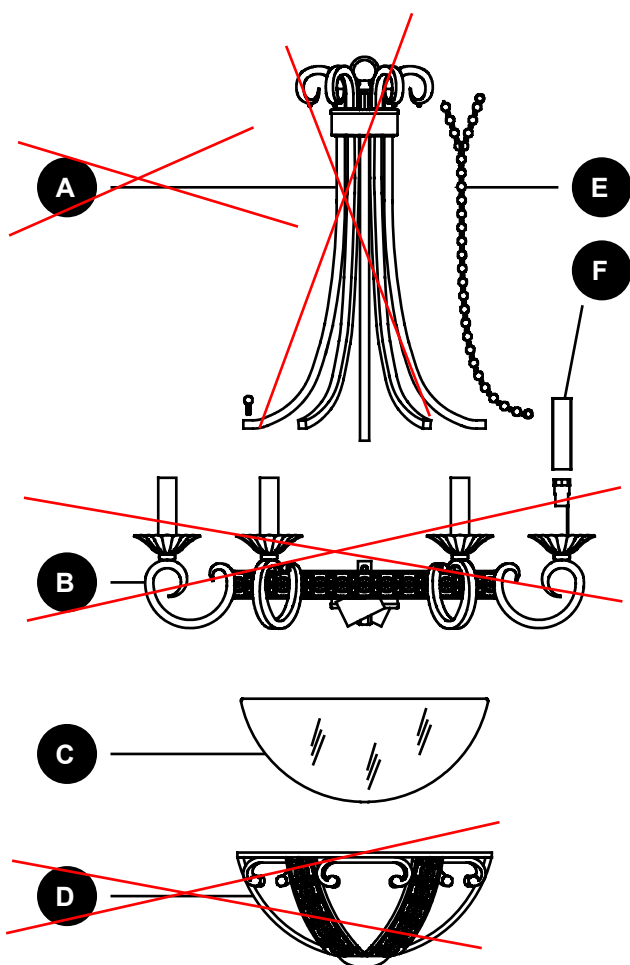

PIEZA	DESCRIPCIÓN	PIEZA #
C	Pantalla	BE0367
E	Cadena con reborde	DB0193
F	Casquillo	AF0020
AA	Tornillo para la caja de salida	EK0032
BB	Tuerca hexagonal	EZ0001
CC	Placa perforada	AG0029
DD	Manguito roscado de montaje	EB0045
EE	Conector de cables	DF0021
FF	Cubierta	AB0194
GG	Enganche del anillo	AD0020
HH	Cadena	AZ0003
II	Malla ciclónica	AZ0003-1
JJ	Tornillo verde de puesta a tierra	EZ0071
KK	Aro de enganche del anillo	AD0020-1
LL	Tuerca esférica con montante	AC0057
MM	Manguito roscado	ED0130
NN	Tuerca esférica	AC0041
OO	Arandela de goma	DF0008
PP	Espaciador	EZ0017
QQ	Base con forma de flor	AB0342
RR	Flor decorativa	AZ0521

LISTA DE PIEZAS DE REPUESTO

Para obtener piezas de repuesto, llame a nuestro Departamento de Servicio al Cliente al 1-800-643-0067, de lunes a jueves de 8 a.m. a 6 p.m., y los viernes de 8 a.m. a 5 p.m., hora estándar del Este.

