

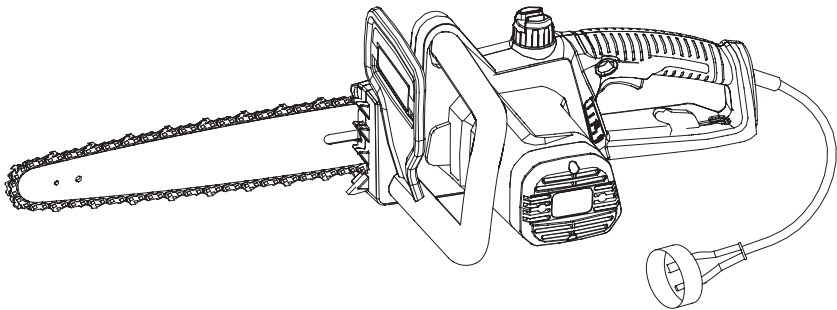

greenworks™

16" 12A ELECTRIC CHAINSAW

2022



Owner's Manual

TOLL-FREE HELPLINE: 1-888-90WORKS (888.909.6757)

 Read all safety rules and instructions carefully before operating this tool.

CONTENTS

Introduction.....	2
Specifications	2
Important Safety Instructions.....	3-5
General Safety Rules.....	6-7
Symbols.....	8-9
Electrical.....	10-11
Know Your Chainsaw	12-13
Assembly	14
Operation.....	15-26
Maintenance	27-36
Troubleshooting	36
Warranty	37
Parts/ Parts List.....	38-40

SPECIFICATIONS

16" 12A ELECTRIC CHAIN SAW

Motor	120 V AC, 60 Hz, 12 Amp
Horsepower	3.0 HP
Wattage	1600 W (running watts) 2400 W (starting watts)
Bar length	16" (40.6 cm)
Speed	6000 RPM (No load)
Chain pitch	3/8" (9.5 mm)
Chain gauge	0.05" (1.3 mm)
Chain type	Oregon®
Net weight.....	9.2 lb (4.2 kg)



IMPORTANT SAFETY INSTRUCTIONS

W A R N I N G

Do not attempt to operate this tool until you have read all of the instructions, safety information, etc. contained in this manual thoroughly and understand them completely. Failure to comply may result in accidents involving fire, electric shock, or serious personal injury.

- Do not start cutting until you have a clear work area, secure footing, and a planned retreat path from the falling tree. Cluttered areas invite accidents.
 - Keep all children, bystanders, visitors, and animals out of the work area while starting or cutting with the chainsaw.
 - Do not operate chainsaw in an explosive atmosphere, such as in the presence of flammable liquids, gases, or dust. Power tools create sparks that may ignite the dust or fumes.
-

W A R N I N G

Use outdoor extension cords marked SW-A, SOW-A, STW-A, STOW-A, SJW-A, SJTW-A, or SJTOW-A. These cords are rated for outdoor use, and reduce the risk of electric shock.

- Polarized Plugs. To reduce the risk of electric shock, this tool has a polarized plug (one blade is wider than the other). This plug will only fit into a polarized outlet one way. If the plug does not fit fully into the outlet, reverse the plug. If it still does not fit, contact a qualified electrician to install the proper outlet. Do not change the plug in any way.
 - Make sure your extension cord is in good condition. When using an extension cord, be sure to use one heavy enough to carry the current your product will draw. A wire gauge size (A.W.G.) of at least 14 is recommended for an extension cord 50' (15 m) or less in length. A cord exceeding 100' (30 m) is not recommended. If in doubt, use the next heavier gauge. The smaller the gauge number, the heavier the cord. An undersized cord will cause a drop in line voltage, resulting in loss of power and overheating.
 - Inspect extension cords periodically, and if damaged, have repaired by a licensed electrician. Constantly stay aware of cord location. Following this rule will reduce the risk of electric shock or fire.
 - Wear snug fitting clothing. Always wear heavy, long pants, overalls, jeans or chaps made of cut-resistant material or ones that contain cut-resistant inserts. Wear non-slip safety footwear. Wear non-slip heavy duty gloves to improve your grip and to protect your hands. Do not wear jewellery, short pants, sandals, or go barefoot. Do not wear loose-fitting clothing that could be drawn into the motor or catch the chain or underbrush. Secure hair so it is above shoulder level.
 - Heavy protective clothing may increase operator fatigue, which could lead to heat stroke.
 - During weather that is hot and humid, heavy work should be scheduled for early morning or late afternoon hours, when temperatures are cooler.
 - Wear eye protection that is marked to comply with ANSI Z87.1 as well as hearing and head protection when operating this equipment. Hearing protection should be worn.
 - Always be aware of what you are doing when using the chainsaw. Use common sense. Do not operate the chainsaw when you are tired, ill, or under the influence of alcohol, drugs, or medication.
-

IMPORTANT SAFETY INSTRUCTIONS

- Do not expose the chainsaw to rain.
- Do not use the chainsaw in damp or wet locations.
- Stay alert and pay attention to what you are doing.
- Keep all parts of your body away from the saw chain when the unit is running.
- Always carry the chainsaw by the front handle with the battery removed and the guide bar and saw chain positioned to the rear.
- Never let anyone use your chainsaw who has not received adequate instructions in its proper use. This applies to rentals as well as privately owned saws.
- Before you start the unit, make sure the saw chain is not contacting any object.
- Stop the chain saw before setting it down.
- To avoid accidental starting, never carry the unit with your finger on the trigger switch .
- Maintain the unit with care. Keep the cutting edge sharp and clean for best performance and to reduce the risk of injury. Follow instructions for lubricating and changing accessories.
- Keep handles dry, clean, and free of oil and grease.
- Do not operate a chainsaw with one hand! Use a firm grip with thumbs and fingers encircling the chainsaw handles. Serious injury to the operator, helpers, bystanders, or any combination of these persons may result from one-handed operation. A chainsaw is intended for two-handed use.
- Avoid body contact with grounded surfaces such as metal pipes and wire fences. There is an increased risk of electric shock if your body is grounded.
- Do not operate a chainsaw that is damaged, improperly adjusted, or not completely and securely assembled. Chain should slow to a stop when the trigger switch is released. If the chain continues to turn after the trigger switch has been released, have the unit serviced by your nearest GreenWorks™ service dealer.
- Check for damaged parts, misalignment or binding of moving parts, broken parts and mountings, and any other condition that may affect the operation of the tool.
- All chainsaw service, other than the items listed in the operation and maintenance sections, should be performed by your nearest GreenWorks™ service dealer.
- Always maintain a proper stance.
- Do not use chainsaw if switch does not turn it on and off. Have defective switch replaced by authorized service centre.
- Do not adapt your chainsaw to a bow guide or use it to power any attachments or devices not listed for the saw.
- Disconnect chainsaw from power supply when not in use, before servicing, and when making adjustments and changing attachments, such as saw chain and guard.
- Do not cut vines and/or small underbrush.
- Do not operate a chainsaw in a tree, on a ladder, or on scaffolding. Doing so is extremely dangerous.

NOTE: The size of the work area depends on the job being performed as well as the size of the tree or workpiece involved. For example, felling a tree requires a larger work area than making bucking cuts.

IMPORTANT SAFETY INSTRUCTIONS

- Use extreme caution when cutting small brush and saplings, because small material may catch the saw chain and be whipped toward you or pull you off balance.
- When cutting a limb that is under tension, be alert for spring back, so that you will not be struck when the tension in the wood fibers is released.
- Do not force the chainsaw. The job can be performed better if the saw is used at the rate that it was designed to work at.
- Always use the right product for your application. The chainsaw should be used for cutting wood only. Never use the chainsaw to cut plastic, masonry or non-wooden building materials.
- Do not use the chainsaw for purposes other than what it is intended for.
- Store chainsaw when not in use. Chainsaw should be stored in a dry and high or locked area, out of the reach of children.
- **Save these instructions.** Refer to them frequently, and use them to instruct others who may use this tool. If you loan someone this tool, also loan them these instructions.

W A R N I N G

Some dust created by power sanding, sawing, grinding, drilling, and other construction activities contains chemicals known to cause cancer, birth defects or other reproductive harm. Some examples of these chemicals are:

- lead from lead-based paints
- crystalline silica from bricks and cement and other masonry products, and
- arsenic and chromium from chemically treated lumber.

Your risk of exposure to these chemicals varies depending on how often you do this type of work. To reduce your exposure to these chemicals, work in a well-ventilated area, and work with approved safety equipment, such as dust masks that are specially designed to filter out microscopic particles.

SAVE THESE INSTRUCTIONS

GENERAL SAFETY RULES

KICKBACK (See Fig. 1 - 2.)

⚠ WARNING

Kickback may occur when the moving chain contacts an object at the upper portion of the tip of the guide bar, or when the wood closes in and pinches the saw chain in the cut. Contact at the upper portion of the tip of the guide bar can cause the chain to dig into the object and stop the chain for an instant. The result is a lightning fast reverse reaction that kicks the guide bar up and back toward the operator. If the saw chain is pinched along the top of the guide bar, the guide bar can be driven rapidly back toward the operator. Either of these reactions can cause loss of saw control, which can result in serious injury. Do not rely exclusively on the safety devices built into the saw. As a chainsaw user, you should take several steps to keep your cutting jobs free from accident or injury.

THE FOLLOWING PRECAUTIONS SHOULD BE FOLLOWED TO MINIMIZE KICKBACK:

1. Always grip the saw firmly with both hands. Hold the saw firmly with both hands when the unit is running. Place your right hand on the rear handle and your left hand on the front handle, with your thumbs and fingers encircling the chain saw handles. A firm grip and a stiff left arm will help you maintain control of the saw if kickback occurs.
 2. Make sure that the area in which you are cutting is free of obstructions. Do not let the nose of the guide bar contact a log, branch, fence, or any other obstruction that could be hit while you are operating the saw.
 3. Always cut with the unit running. Fully squeeze the trigger switch and maintain cutting speed.
 4. Use only the replacement guide bars and low-kickback chains specified by the manufacturer for the saw.
- With a basic understanding of kickback, you can reduce or eliminate the element of surprise. Sudden surprise contributes to accidents.
 - Keep proper footing and balance at all times.
 - Do not cut above shoulder height or overreach when cutting.
 - Follow the sharpening and maintenance instructions for the saw chain.

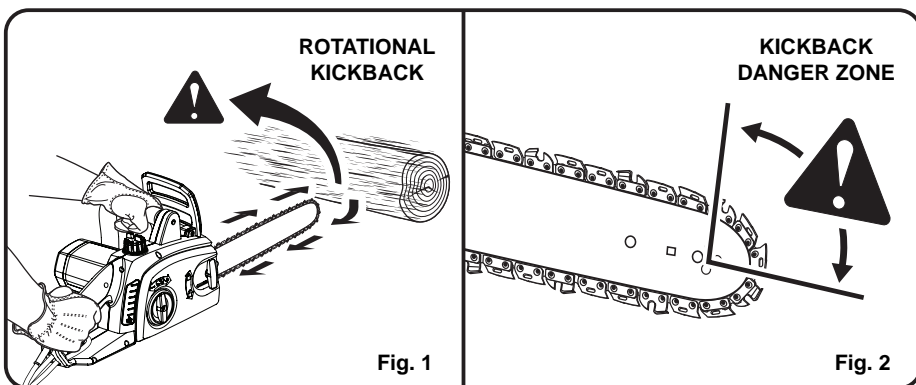

GENERAL SAFETY RULES

- Push and Pull — This reaction force is always opposite to the direction the chain is moving where contact is made with the wood. Thus, the operator must be ready to control the PULL when cutting on the bottom edge of the bar, and the PUSH when cutting along the top edge. (See Fig. 3)

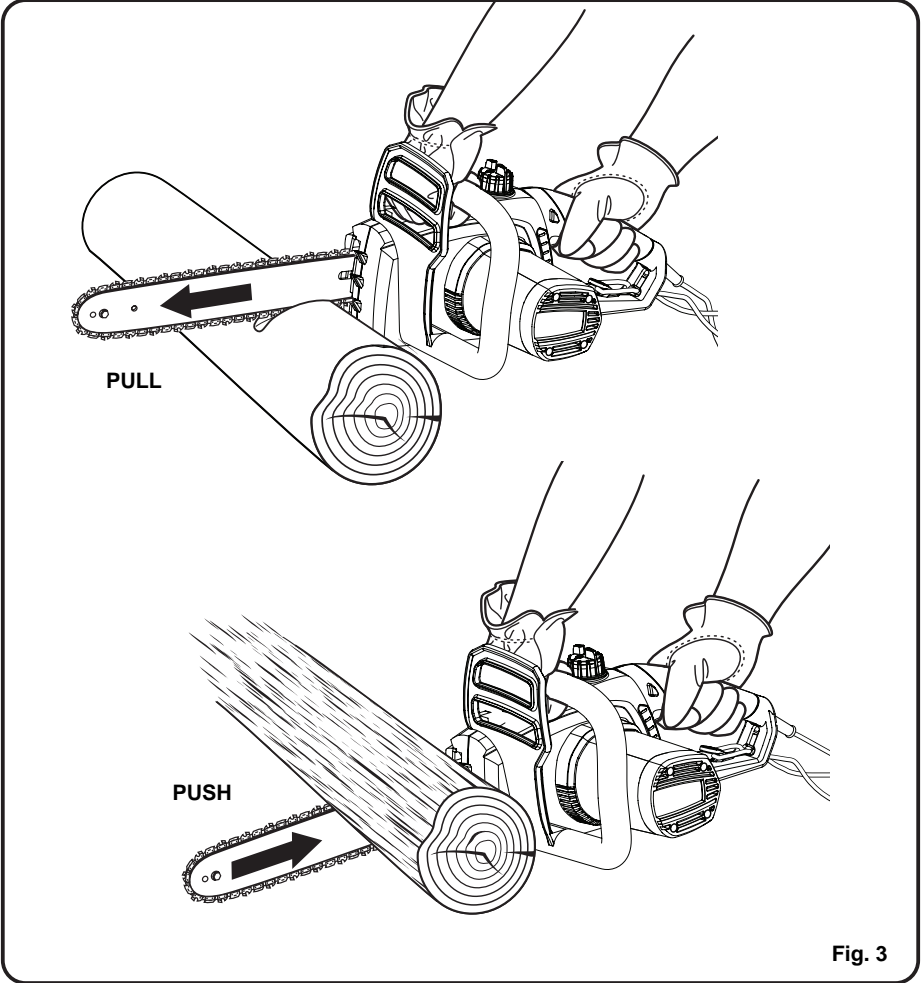













Fig. 3



SYMBOLS

Some of the following symbols may be used on this product. Please study them and learn their meaning. Proper interpretation of these symbols will allow you to operate the product better and safer.

SYMBOL	NAME	DESIGNATION/EXPLANATION
V	Volts	Voltage
A	Amperes	Current
Hz	Hertz	Frequency (cycles per second)
W	Watts	Power
min	Minutes	Time
~	Alternating Current	Type of current
≡	Direct Current	Type or a characteristic of current
n_0	No Load Speed	Rational speed, at no load
	Class II Construction	Double-insulated construction
/min	Per Minute	Revolutions, strokes, surface speed, orbits etc., per minute
	Wet Conditions Alert	Do not expose to rain or use in damp locations
	Read The Operator's Manual	To reduce the risk of injury user must read and understand operator's manual before using this product.
	Eye and Head Protection	Wear eye and head protection when operating this equipment.
	Safety Alert	Precautions that involve your safety.
	Operate With Two Hands	Hold and operate the saw properly with both hands
	Kickback	DANGER! Beware of kickback.
	Bar Nose Contact	Avoid bar nose contact.
	Wear Gloves	Wear non-slip, heavy-duty protective gloves when handling the chainsaw.
	Wear Safety Footwear	Wear non-slip safety footwear when using this equipment.
	Keep Bystanders Away	Keep all bystanders at least 50 ft. away.

SYMBOLS

The following signal words and meanings are intended to explain the levels of risk associated with this product.

SYMBOL	SIGNAL	MEANING
	DANGER	Indicates an imminently hazardous situation, which, if not avoided, will result in death or serious injury.
	WARNING	Indicates a potentially hazardous situation, which, if not avoided, could result in death or serious injury.
	CAUTION	Indicates a potentially hazardous situation, which, if not avoided, may result in minor or moderate injury.
	CAUTION	(Without Safety Alert Symbol) Indicates a situation that may result in property damage.

SERVICE

Servicing requires extreme care and knowledge and should be performed only by a qualified service technician. For service we suggest you return the product to your nearest **AUTHORIZED SERVICE CENTER** for repair. When servicing, use only identical replacement parts.

W A R N I N G

To avoid serious personal injury, do not attempt to use this product until you have read this Owner's Manual thoroughly and understand it completely. If you do not understand the warnings and instructions in this Owner's Manual, do not use this product. Call the Toll-free Helpline (1-888-909-6757) for assistance. The operation of any power tool can result in foreign objects being thrown into your eyes, which can result in severe eye damage. Before operating a power tool, always wear safety goggles, safety glasses with side shields, or a full face shield when needed. We recommend a Wide Vision Safety Mask for use over eyeglasses or standard safety glasses with side shields. Always use eye protection that is marked to comply with ANSI Z87.1.

W A R N I N G

 The operation of any power tool can result in foreign objects being thrown into your eyes, which can result in severe eye damage. Before beginning power tool operation, always wear safety goggles or safety glasses with side shields and, when needed, a full face shield. We recommend Wide Vision Safety Mask for use over eyeglasses or standard safety glasses with side shields. Always use eye protection which is marked to comply with ANSI Z87.1.

SAVE THESE INSTRUCTIONS

ELECTRICAL

⚠ WARNING

TO AVOID ELECTRICAL HAZARDS, FIRE HAZARDS, OR DAMAGE TO THE TOOL, USE PROPER CIRCUIT PROTECTION. THIS CHAINSAW IS WIRED AT THE FACTORY FOR 120 V OPERATION. CONNECT TO A 120 V, 15 A CIRCUIT, AND USE A 15 A TIME-DELAYED FUSE OR CIRCUIT BREAKER. TO AVOID SHOCK OR FIRE WHEN THE POWER CORD IS WORN, CUT, OR DAMAGED IN ANY WAY, REPLACE IT IMMEDIATELY.

DOUBLE INSULATED (See Fig. 4)

This chainsaw has a plug that looks like the one shown in Fig. 4. The chainsaw is double insulated to provide a double thickness of insulation between you and the tool's electrical system. All exposed metal parts are isolated from the internal metal motor components with protective insulation.

⚠ WARNING

TO AVOID INJURY, USE ONLY IDENTICAL CHAINSAW REPLACEMENT PARTS

⚠ WARNING

DOUBLE INSULATION DOES NOT TAKE THE PLACE OF NORMAL SAFETY PRECAUTIONS WHEN OPERATING THIS TOOL.

⚠ WARNING

TO AVOID ELECTRIC SHOCK:

1. Use only identical replacement parts when servicing a tool with double insulation. Servicing should be performed by a qualified technician.
 2. Do not use in wet or damp areas or expose to rain.
-

⚠ CAUTION

IN ALL CASES, MAKE CERTAIN THE RECEPTACLE IN QUESTION IS PROPERLY GROUNDED. IF YOU ARE NOT SURE, HAVE A CERTIFIED ELECTRICIAN CHECK THE RECEPTACLE.

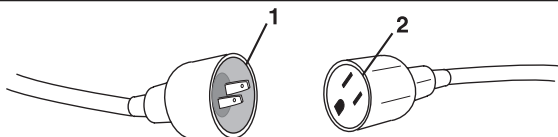

- 1) 2-prong plug
- 2) Properly grounded extension cord

Fig. 4

ELECTRICAL

WARNING

THIS LAWN TOOL IS FOR OUTDOOR USE ONLY. DO NOT EXPOSE TO RAIN OR USE IN DAMP LOCATIONS.

GUIDELINES FOR USING EXTENSION CORDS

USE THE PROPER EXTENSION CORD. Make sure your extension cord is in good condition. When using an extension cord, be sure to use one of heavy enough gauge to carry the current your product will draw. An undersized cord will cause overheating. The table below shows the correct size to use depending on cord length and nameplate ampere rating. If in doubt, use the next heavier gauge. The smaller the gauge number, the heavier the cord.

MINIMUM GAUGE FOR EXTENSION CORDS (AWG)

(WHEN USING 120 V ONLY)

Amp Rating		Total Length of Cord in Feet (meters)			
More Than	Not More Than	25' (7.6 m)	50' (15 m)	100' (30.4 m)	150' (45.7 m)
0	6	18	16	16	14
6	10	18	16	14	12
10	12	16	16	14	12
12	16	14	12	Not Recommended	

Be sure your extension cord is properly wired and in good condition. Always replace a damaged extension cord or have it repaired by a qualified person before using it. Keep your extension cords away from sharp objects, excessive heat and damp or wet areas.

Use a separate electrical circuit for your tools. This circuit must not be less than 12-gauge cord and should be protected with a 15-amp time delayed fuse. Before connecting the motor to the power line, make sure the switch is in the OFF position and the electric current is rated the same as the current stamped on the motor nameplate. Running at a lower voltage will damage the motor.

WARNING

THIS TOOL MUST BE GROUNDED WHILE IN USE TO PROTECT THE OPERATOR FROM ELECTRICAL SHOCK.

SAVE THESE INSTRUCTIONS

KNOW YOUR CHAINSAW

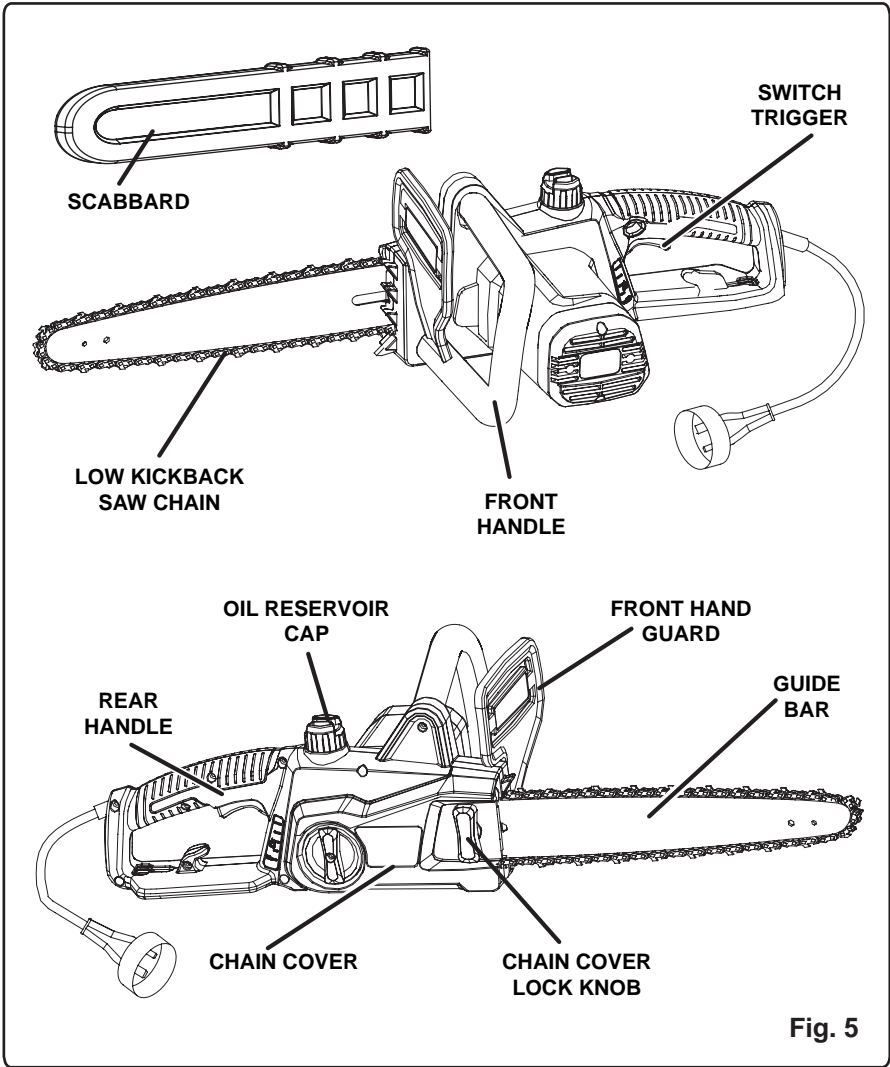

Fig. 5

KNOW YOUR CHAINSAW

The safe use of this product requires an understanding of the information on the tool and in this Owner's Manual, as well as a knowledge of the project you are attempting. Before using this product, familiarize yourself with all operating features and safety rules.

CHAIN TENSIONING KNOB

This feature allows user to adjust the tension of the chain.

GUIDE BAR

The factory-equipped guide bar has a small radius tip that offers a somewhat lower kickback potential.

LOW-KICKBACK SAW CHAIN

The low-kickback saw chain helps minimize the force of a kickback reaction by preventing the cutters from digging in too deeply at the kickback zone.

QUICK-VIEW OIL INDICATOR

Semi-transparent oil reservoir that allows user to see when to add oil.

SWITCH LOCK

A control feature designed to prevent the motor from being started accidentally..

TRIGGER SWITCH

Squeeze the trigger switch to operate the unit after switch lock has been pushed in. Release the trigger switch to stop the unit.

ASSEMBLY

UNPACKING

This product has been shipped completely assembled.

- Carefully remove the product and any accessories from the box. Make sure that all items listed in the packing list are included.
- Inspect the product carefully to make sure no breakage or damage occurred during shipping.
- Do not discard the packing material until you have carefully inspected and satisfactorily operated the product.
- If any parts are damaged or missing, please call 1-888-909-6757 for assistance.

PACKING LIST

- Chainsaw
- Scabbard
- Owner's Manual

W A R N I N G

If any parts are damaged or missing, do not operate this product until the parts are replaced. Failure to heed this warning could result in serious personal injury.

W A R N I N G

Do not connect to power supply until assembly is complete. Failure to comply could result in accidental starting and possible serious personal injury.

W A R N I N G

Do not attempt to modify this product or create accessories not recommended for use with this product. Any such alteration or modification is misuse, and could result in a hazardous condition leading to possible serious personal injury.

OPERATION

⚠ WARNING

Do not allow familiarity with this product to make you careless. Remember that a careless fraction of a second is sufficient to inflict serious injury.

⚠ WARNING

Always wear safety goggles or safety glasses with side shields when operating power tools. Failure to do so could result in objects being thrown into your eyes, resulting in possible serious injury.

⚠ WARNING

Do not use any attachments or accessories not recommended by the manufacturer of this product. The use of attachments or accessories not recommended can result in serious personal injury.

APPLICATIONS

You can use this product for the purposes listed below:

- Basic limbing, felling, and woodcutting
- Removing buttress roots

ADDING BAR AND CHAIN LUBRICANT (See Fig. 6)

Use GREENWORKS Bar and Chain Lubricant. It is designed for chains and chain oilers, and is formulated to perform over a wide temperature range with no dilution required.

NOTE: The chainsaw comes from the factory with no bar and chain oil added. Level should also be checked after every 20 minutes of use, and refilled as needed.

- Remove oil cap.
- Carefully pour the bar and chain oil into the tank.
- Wipe off excess oil.
- Check and fill the oil tank when quick-view oil indicator is below the MIN. line.
- Repeat as needed.

NOTE: Do not use dirty, used or otherwise contaminated oils. Damage may occur to the bar or chain.

NOTE: It is normal for oil to seep from the saw when not in use. To prevent seepage, empty the oil tank after each use, then run for one minute. When storing the unit for a long period of time (three months or longer), be sure the chain is lightly lubricated. This will prevent rust on the chain and bar sprocket.

OPERATION

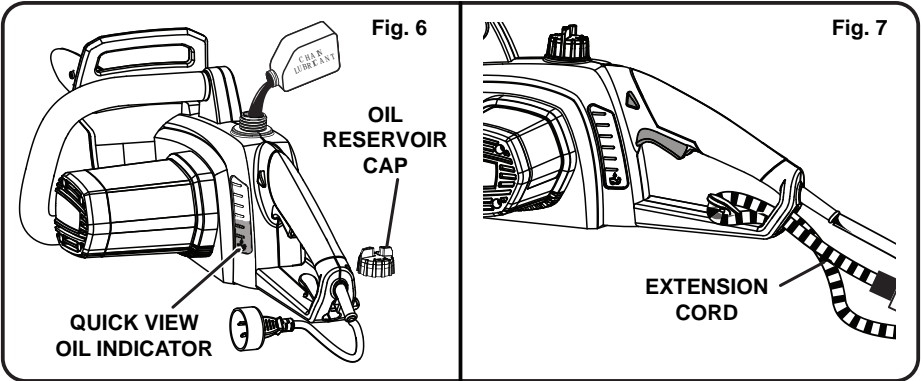

CONNECTING TO POWER SUPPLY (See Fig. 7)

This chainsaw is designed with a cord retainer that prevents the extension cord from being pulled loose while using.

- Form a loop with the end of the extension cord.
- Insert loop portion of extension cord through the opening in the side of the rear handle, and place over cord hitch.
- Slowly pull loop against cord retainer until the slack is removed.
- Plug chainsaw into extension cord.

NOTE: Failure to remove all excess cord slack from extension cord retainer could result in plug loosening from receptacle.

STARTING AND STOPPING THE CHAINSAW (See Fig. 8)

⚠ WARNING

Keep body to the left of the chain line. Never straddle the saw or chain, or lean over past the chain line.

OPERATION

Starting the chain saw:

- Make sure chain tension is at desired setting. Refer to **Adjusting the Chain Tension** in the Maintenance section of this manual.
- Make sure the chain cover lock knob is tight to the chain cover.
- Make sure no objects or obstructions are in immediate vicinity which could come into contact with the bar and chain.
- Press and hold the switch lock. This makes the trigger switch operational.
- Press and hold the trigger switch, release the switch lock, and continue to squeeze the trigger switch for continued operation.

Stopping the chainsaw:

NOTE: It is normal for the chain to coast to a stop once the trigger switch is released.

- Release the trigger switch to stop the chainsaw.
- Upon release of the trigger switch, the switch lock will be automatically reset to the lock position.

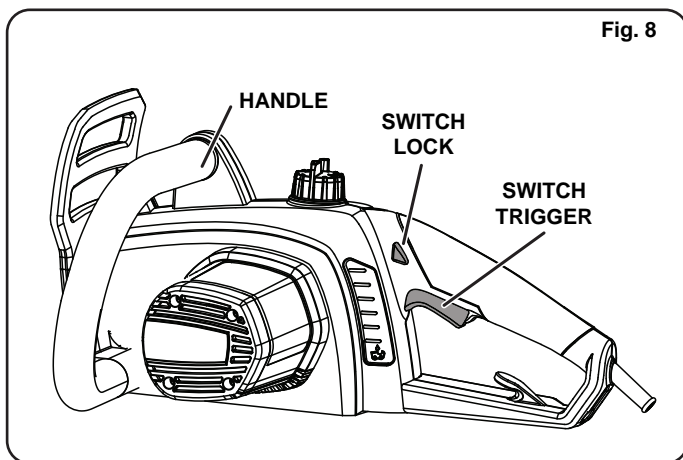

OPERATION

PREPARING FOR CUTTING

PROPER GRIP ON HANDLES (See Fig. 9)

See General Safety Rules for appropriate safety equipment.

- Wear non-slip gloves for maximum grip and protection.
- Hold the saw firmly with both hands. Always keep your left hand on the front handle and your right hand on the rear handle so that your body is to the left of the chain line.
- Maintain a proper grip on the saw whenever the motor is running. The fingers should encircle the handle, with the thumb wrapped under the handlebar. This grip is least likely to be broken by a kickback or other sudden reaction of the saw. Any grip in which the thumb and fingers are on the same side of the handle is dangerous, because a slight kick of the saw can cause loss of control.

⚠ WARNING

Never use a left-handed (cross-handed) grip or any stance that would place your body or arm across the chain line.

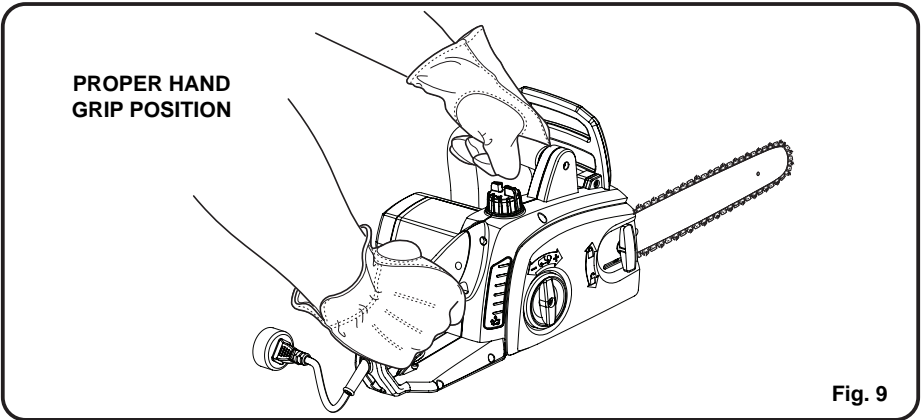

⚠ WARNING

DO NOT operate the trigger switch with your left hand and hold the front handle with your right hand. Never allow any part of your body to be in the chain line while operating a saw.

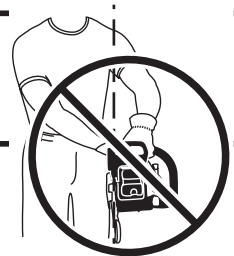

**CHAIN
LINE** →

OPERATION

PROPER CUTTING STANCE (See Fig. 10)

- Balance your weight with both feet on solid ground.
- Keep left arm with elbow locked in a “straight arm” position to withstand any kickback force.
- Keep your body to the left of the chain line.
- Keep your thumb on underside of handlebar.

BASIC OPERATING/CUTTING PROCEDURES

Practice cutting a few small logs using the following technique to get the “feel” of using the saw before you begin a major sawing operation.

- Take the proper stance in front of the wood with the saw idling.
- Press the switch lock and squeeze the trigger switch, then release switch lock and let the chain accelerate to full speed before entering the cut.
- Begin cutting with the saw against the log.
- Keep the unit running the entire time you are cutting, maintain a steady speed.
- Allow the chain to cut for you; exert only light downward pressure. Forcing the cut could result in damage to the bar, chain, or motor.
- Release the trigger switch as soon as the cut is completed, allowing the chain to stop. If you run the saw without a cutting load, unnecessary wear can occur to the chain, bar, and unit.
- Do not put pressure on the saw at the end of the cut.

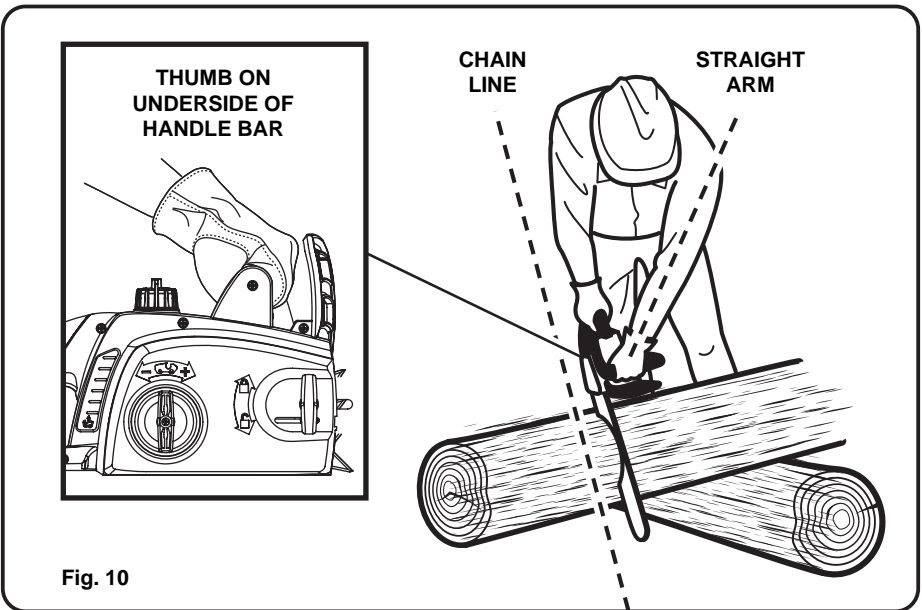

Fig. 10

OPERATION

WORK AREA PRECAUTIONS (See Fig. 11)

- Cut only wood or materials made from wood; no sheet metal, no plastics, no masonry, no non-wooden building materials.
- Never allow children to operate the saw. Allow no person to use this chainsaw who has not read this Owner's Manual or received adequate instructions for the safe and proper use of this chainsaw.
- Keep everyone – helpers, bystanders, children, and animals – a **SAFE DISTANCE** from the cutting area. During felling operations, the safe distance should be a least twice the height of the largest trees in the felling area. During bucking operations, keep a minimum distance of 15' (4.6 m) between workers.
- Always cut with both feet on solid ground to prevent being pulled off balance.
- Do not cut above chest height, because a saw held higher is difficult to control against kickback forces.
- Do not fell trees near electrical wires or buildings. Leave this operation for professionals.
- Cut only when visibility and light are adequate for you to see clearly.



Fig. 11

FELLING TREES

HAZARDOUS CONDITIONS (See Fig. 12)

When felling a tree, it is important that you heed the following warnings to prevent possible serious injury

OPERATION

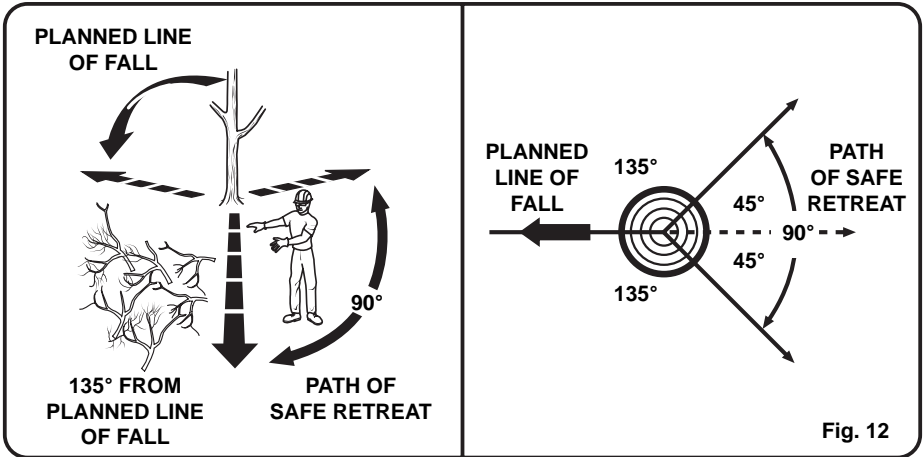

Fig. 12

- Do not cut down trees having an extreme lean, or large trees with rotten limbs, loose bark or hollow trunks. Have these trees pushed or dragged down with heavy equipment, then cut them up.
- Do not cut trees near electrical wires or buildings
- Check the tree for damaged or dead branches that could fall and hit you during felling
- Periodically glance at the top of the tree during the backcut to assure the tree is going to fall in the desired direction
- If the tree starts to fall in the wrong direction, or if the saw gets caught or hung up during the fall, leave the saw and save yourself!

⚠ WARNING

Do not fell trees during periods of high wind or heavy precipitation. Wait until the hazardous weather has ended.

PROPER PROCEDURE FOR TREE FELLING (See Fig. 13)

- Felling a tree — When bucking and felling operations are being performed by two or more persons at the same time, the felling operations should be separated from the bucking operation by a distance of at least twice the height of the tree being felled. Trees should not be felled in a manner that would endanger any person, strike any utility line, or cause any property damage. If the tree does make contact with any utility line, the utility company should be notified immediately.
- Operator should keep on the uphill side of terrain as the tree is likely to roll or slide after it is felled.
- Pick your escape route (or routes in case the intended route is blocked). Clear the immediate area around the tree and make sure there are no obstructions in your planned path of retreat. Clear the path of safe retreat approximately 135° from the planned line of fall.

OPERATION

- Consider the force and direction of the wind, the lean and balance of the tree, and the location of large limbs. These things influence the direction in which the tree will fall. Do not try to fell a tree along a line different from its natural line of fall.
- Remove dirt, stones, loose bark, nails, staples, and wire from the tree where felling cuts are to be made.

Notched Undercut:

- Cut a notch about 1/3 the diameter of the trunk in the side of the tree. Make the notch cuts so they intersect at a right angle to the line of fall. This notch should be cleaned out to leave a straight line. To keep the weight of the wood off the saw, always make the lower cut of the notch before the upper cut.

Felling Backcut:

- As the felling cut gets close to the hinge, the tree should begin to fall. If there is any chance the tree may not fall in the desired direction or it may rock back and bind the saw chain, stop cutting before the felling cut is complete, and use wedges of wood, plastic or aluminum to open the cut and drop the tree along its desired line of fall. Make the backcut level and horizontal, at least 2" (5 cm) above the horizontal cut of the notch.

NOTE: Never cut through to the notch. Always leave a band of wood between the notch and back cut (approximately 2" (5 cm) or 1/10 the diameter of the tree). This is called "hinge" or "hingewood." It controls the fall of the tree, and prevents slipping or twisting or shootback of the tree off the stump.

- On large diameter trees, stop the back cut before it is deep enough for the tree to either fall or settle back on the stump. Then insert soft wooden or plastic wedges into the cut so they do not touch the chain. Drive wedges in, little by little, to help jack the tree over.
- As tree starts to fall, stop the chainsaw and put it down immediately. Retreat along the cleared path, but watch the action in case something falls your way.

⚠ WARNING

Never cut through to the notch when making a back cut. The hinge controls the fall of the tree. This is the section of wood between the notch and backcut.

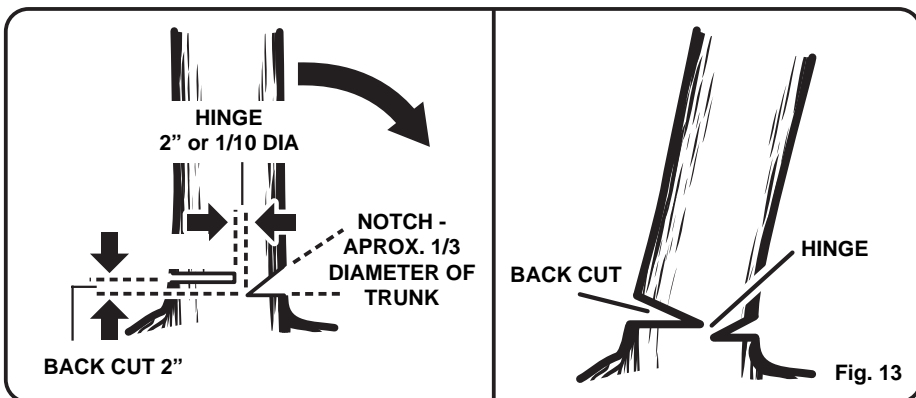

OPERATION

REMOVING BUTTRESS ROOTS (See Fig. 14)

A buttress root is a large root extending from the trunk of the tree above the ground. Remove large buttress roots prior to felling. Make the horizontal cut into the buttress first, followed by the vertical cut. Remove the resulting loose section from the work area. Follow the correct tree felling procedure as stated in Proper Procedure For Tree Felling after you have removed the large buttress roots.

BUCKING (See Fig. 15)

Bucking is the term used for cutting a fallen tree to the desired log length.

- Always make sure your footing is secure and your weight is distributed evenly on both feet.
- Cut only one log at a time.
- Support small logs on a saw horse or another log while bucking.
- Keep a clear cutting area. Make sure no objects can contact the guide bar nose and chain during cutting, because this can cause kickback.
- When bucking on a slope, always stand on the uphill side of the log. To maintain complete control of the chainsaw when cutting through the log, release the cutting pressure near the end of the cut without relaxing your grip on the chainsaw handles. Do not let the chain contact the ground. After completing the cut, wait for the saw chain to stop before you move the chainsaw. Always stop the motor before moving from tree to tree.

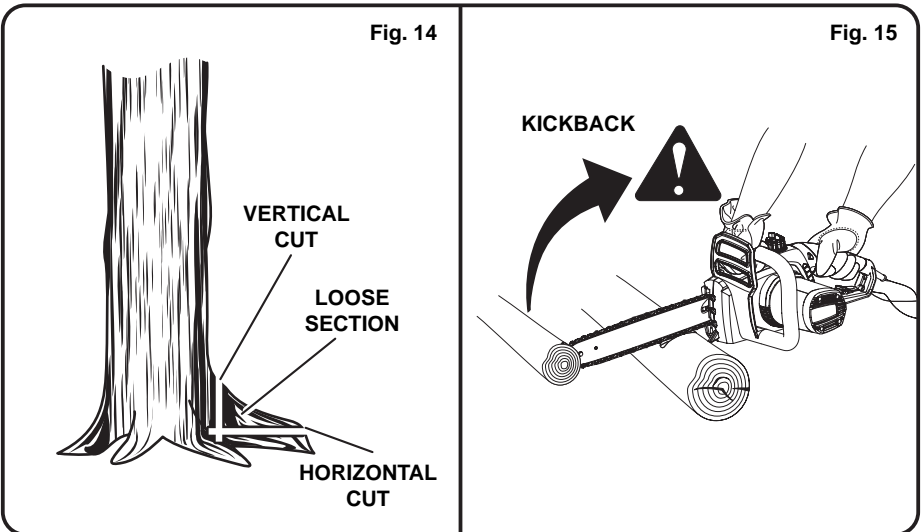

OPERATION

BUCKING WITH A WEDGE (See Fig. 16)

If the wood diameter is large enough for you to insert a soft bucking wedge without touching the chain, you should use the wedge to hold the cut open to prevent pinching.

BUCKING LOGS UNDER STRESS (See Fig. 17)

Make the first bucking cut 1/3 of the way through the log, and finish with a 2/3 cut on the opposite side. As you cut the log, it will tend to bend. The saw can become pinched or hung in the log if you make the first cut deeper than 1/3 of the diameter of the log. Give special attention to logs under stress to prevent the bar and chain from pinching.

OVERBUCKING (See Fig. 18)

Begin on the top side of the log with the bottom of the saw against the log; exert light pressure downward. Note that the saw will tend to pull away from you.

UNDERBUCKING (See Fig. 19)

Begin on the under side of the log with the top of the saw against the log; exert light pressure upward. During underbucking, the saw will tend to push back at you. Be prepared for this reaction, and hold the saw firmly to maintain control.

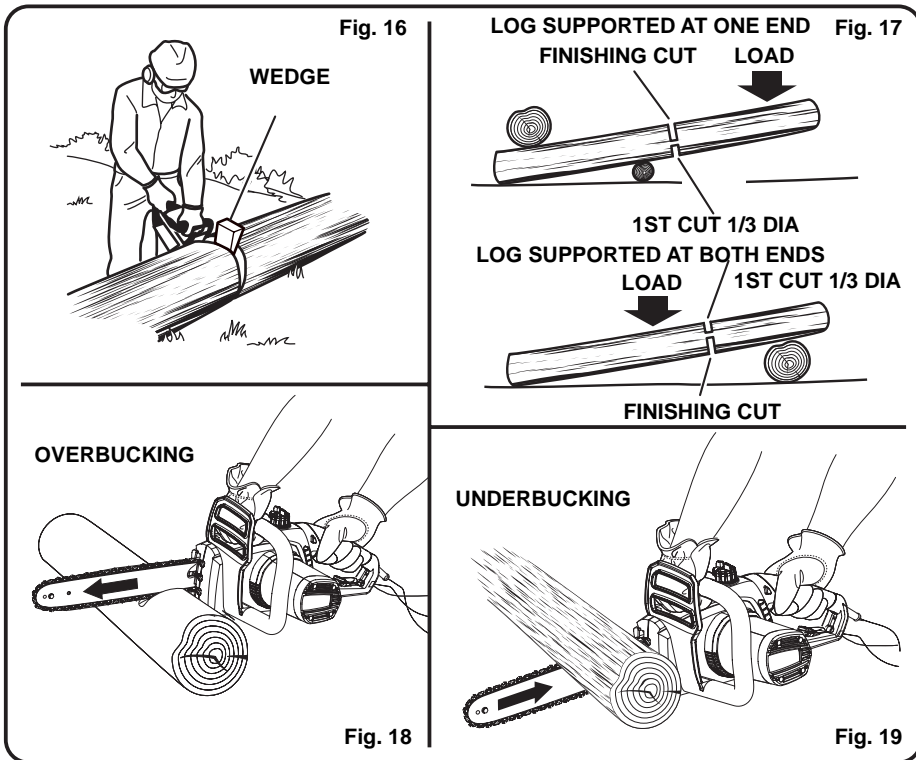

OPERATION

LIMBING (See Fig. 20)

Limbing is removing branches from a fallen tree.

- Work slowly, keeping both hands on the chainsaw with a firm grip. Always make sure your footing is secure and your weight is distributed evenly on both feet.
- Leave the larger support limbs under the tree to keep the tree off the ground while cutting.
- Limbs should be cut one at a time. Remove the cut limbs from the work area often to help keep the work area clean and safe.
- Branches under tension should be cut from the bottom up to avoid binding the chainsaw.
- Keep the tree between you and the chainsaw while limbing. Cut from the side of the tree opposite the branch you are cutting.

PRUNING (See Fig. 21)

Pruning is trimming limbs from a live tree.

- Work slowly, keeping both hands on the chainsaw with a firm grip. Always make sure your footing is secure and your weight is distributed evenly on both feet.
- Do not cut from a ladder. This is extremely dangerous. Leave this operation for professionals.
- Do not cut above chest height, because a saw held higher is difficult to control against kickback.
- When pruning trees, it is important not to make the finishing cut next to the main limb or trunk until you have cut off the limb further out to reduce the weight. This prevents stripping the bark from the main member.
- Underbuck the branch 1/3 through for your first cut.
- Your second cut should overbuck to drop the branch off.
- Now make your finishing cut smoothly and neatly against the main member so the bark will grow back to seal the wound.

⚠ WARNING

Never cut through to the notch when making a back cut. The hinge controls the fall of the tree. This is the section of wood between the notch and backcut.

OPERATION

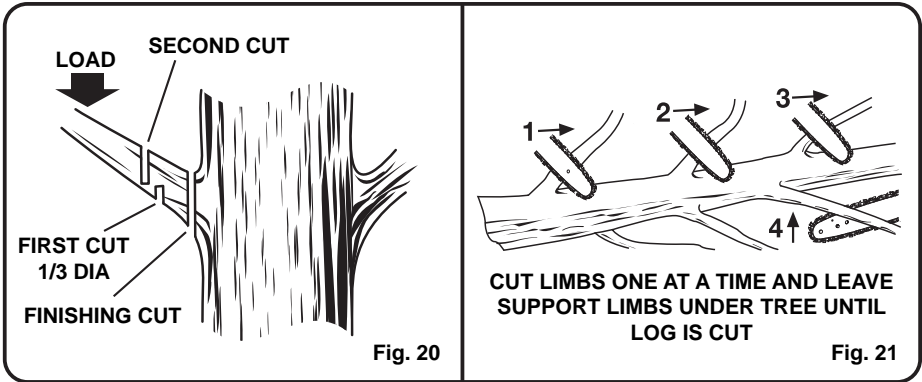

CUTTING SPRINGPOLES (See Fig. 22)

A springpole is any log, branch, rooted stump, or sapling that is bent under tension by other wood, so that it springs back if the wood holding it is cut or removed. On a fallen tree, a rooted stump has a high potential of springing back to the upright position during the bucking cut to separate the log from the stump. Watch out for springpoles — they are dangerous.

⚠ WARNING

Springpoles are dangerous, and could strike the operator, causing the operator to lose control of the chainsaw. This could result in severe or fatal injury to the operator.

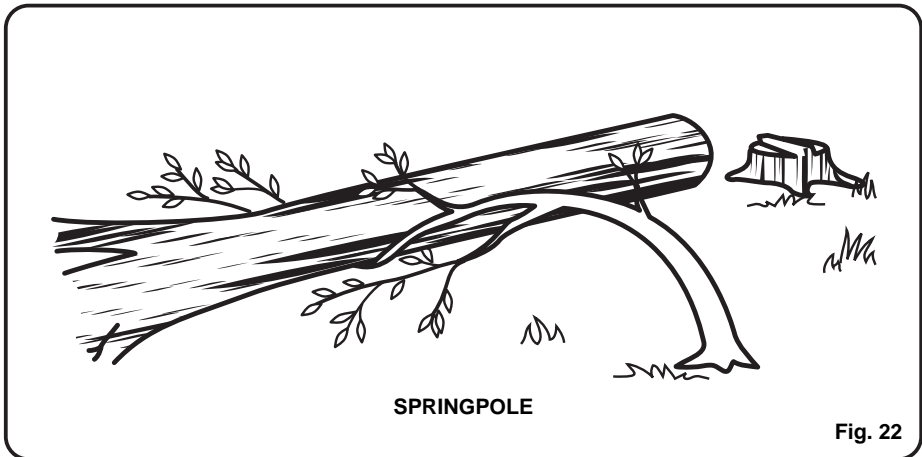

MAINTENANCE

W A R N I N G

When servicing, use only identical GreenWorks™ replacement parts. Use of any other parts may create a hazard or cause product damage.

W A R N I N G

Always wear safety goggles or safety glasses with side shields during power tool operation or when blowing dust. If operation is dusty, also wear a dust mask.

GENERAL MAINTENANCE

Avoid using solvents when cleaning plastic parts. Most plastics are susceptible to damage from various types of commercial solvents. Use a clean cloth to remove dirt, dust, lubricant, grease, etc.

W A R N I N G

Do not let brake fluids, gasoline, petroleum-based products, penetrating lubricants, etc., come into contact with plastic parts at any time. Chemicals can damage, weaken or destroy plastic, which may result in serious personal injury.

LUBRICATION

All of the bearings in this product are lubricated with a sufficient amount of high-grade lubricant for the life of the unit under normal operating conditions. Therefore, no further lubrication is required.

MAINTENANCE

REPLACING THE GUIDE BAR AND CHAIN (See Fig. 23 - 28.)

D A N G E R

Never start the motor before installing the guide bar, chain, chain cover, and chain cover lock knob. Without all these parts in place, the clutch can fly off or explode, exposing the user to possible serious injury.

W A R N I N G

To avoid serious personal injury, read and understand all the safety instructions in this section.

W A R N I N G

Before performing any maintenance, make sure the tool is unplugged from the power supply. Failure to heed this warning could result in serious personal injury.

C A U T I O N

Always wear gloves when handling the bar and chain. These components are sharp and may contain burrs.

W A R N I N G

Never touch or adjust the chain while the motor is running. The saw chain is very sharp. Always wear protective gloves when performing maintenance involving the chain to avoid possible serious lacerations.

*NOTE: When replacing the guide bar and chain, always use the specified bar and chain listed in the **Bar and Chain Combinations** section later in this manual.*

MAINTENANCE

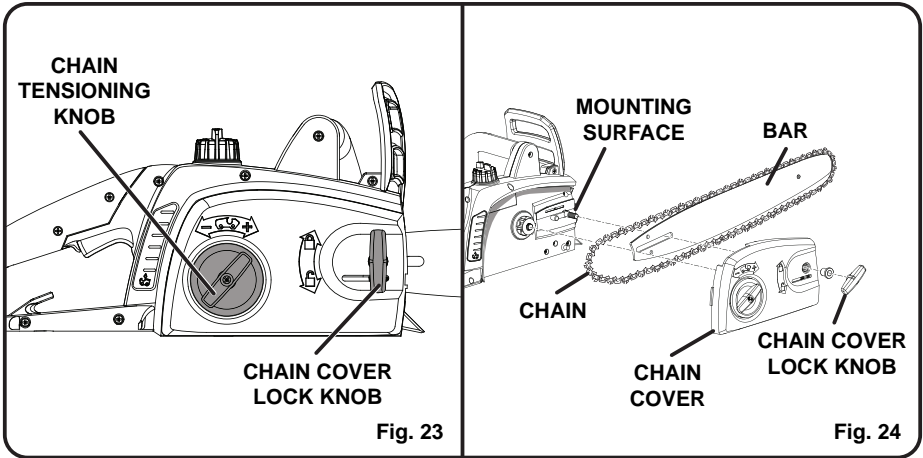

- Disconnect chainsaw from power supply.
- Rotate the chain cover lock knob counter-clockwise, and remove knob.
- Remove the chain cover.
- Remove the bar and chain from the mounting surface.
- Remove the old chain from the bar.
- Lay out the new saw chain in a loop, and straighten any kinks. The cutters should face in the direction of chain rotation. If they face backwards, turn the loop over.
- Place the chain drive links into the bar groove as shown.

NOTE: Make certain of direction of chain.

- Position the chain so there is a loop at the back of the bar.
- Hold the chain in position on the bar, and place the loop around the sprocket.
- Fit the bar flush against the mounting surface so that the bar studs are in the long slot of the bar.

NOTE: When placing the bar on the bar studs, ensure that the adjusting pin is in the chain tension pin hole.

- Replace the chain cover.
- Replace the chain cover lock knob. Rotate knob clockwise to tighten. The bar should still be free to move for tension adjustment.
- Remove all slack from the chain by turning the chain tensioning knob clockwise until the chain seats snugly against the bar with the drive links in the bar groove.
- Lift the tip of the guide bar up to check for sag.

MAINTENANCE

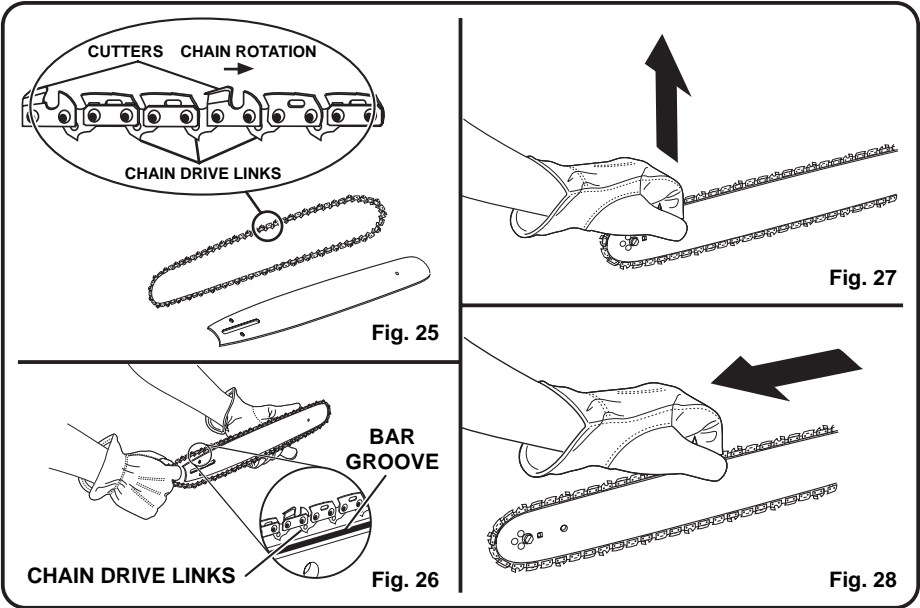

- Release the tip of the guide bar, and turn the chain tensioning knob 1/2 turn clockwise.
- Hold the tip of the guide bar up and tighten the chain cover lock knob.

The chain is correctly tensioned when there is no sag on the underside of the guide bar, and when the chain is snug, but can be turned by hand without binding.

NOTE: If chain is too tight, it will not rotate. Loosen the chain cover lock knob slightly, and turn the chain tensioning knob 1/4 turn counter-clockwise. Lift the tip of the guide bar up, and retighten the chain cover lock knob. Ensure that the chain will rotate without binding.

⚠ WARNING

Never touch or adjust the chain while the motor is running. The saw chain is very sharp. Always wear protective gloves when performing maintenance involving the chain.

ADJUSTING THE CHAIN TENSION (See Fig. 29 - 30.)

- Stop the motor and disconnect from power supply before setting the chain tension.
- Slightly loosen the chain cover lock knob.

MAINTENANCE

- Turn the chain tensioning knob clockwise to tension the chain.

NOTE: A cold chain is correctly tensioned when there is no slack on the underside of the guide bar, the chain is snug, and it can be turned by hand without binding.

- Rotate the chain cover lock knob clockwise to secure. Retension the chain whenever the flats on the drive links hang out of the bar groove.

NOTE: During normal saw operation, the temperature of the chain increases. The drive links of a correctly tensioned warm chain will hang approximately 1/16" (1.3 mm) out of the bar groove.

NOTE: New chains tend to stretch. Check the chain tension frequently and tension as required.

⚠ CAUTION

A chain tensioned while warm may be too tight upon cooling. Check the "cold tension" before next use.

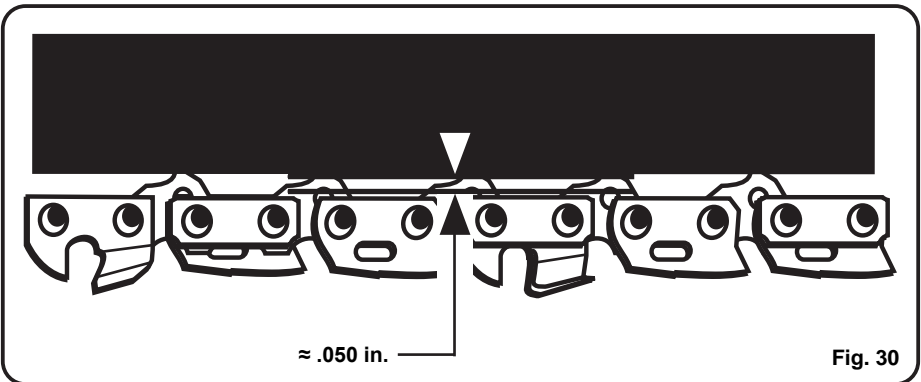
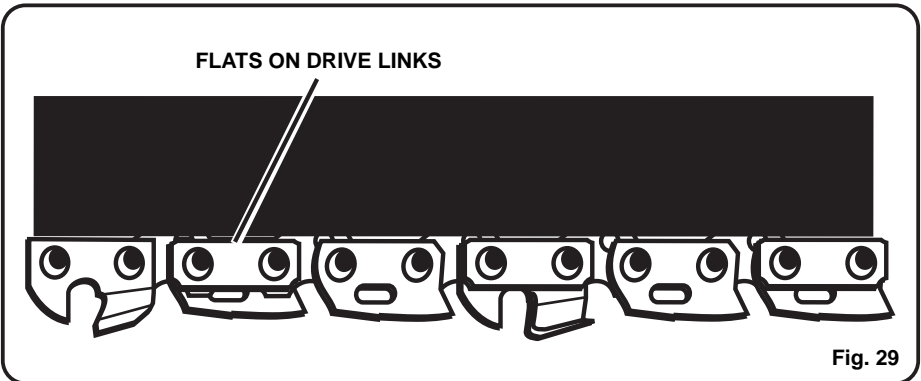

MAINTENANCE

⚠ CAUTION

Make sure the chainsaw is disconnected from the power supply before you work on the saw.

CHAIN MAINTENANCE (See Fig. 31)

Use only a low-kickback chain on this saw. This fast-cutting chain provides kickback reduction when properly maintained. For smooth and fast cutting, maintain the chain properly. The chain requires sharpening when the wood chips are small and powdery, the chain must be forced through the wood during cutting, or the chain cuts to one side. During maintenance of the chain, consider the following:

- Improper filing angle of the side plate can increase the risk of severe kickback.
- Raker (depth gauge) clearance.
- Too low increases the potential for kickback.
- Not low enough decreases cutting ability.
- If the cutter teeth hit hard objects such as nails and stones, or are abraded by mud or sand on the wood, have an authorized service centre sharpen the chain.

NOTE: Inspect the drive sprocket for wear or damage when replacing the chain. If signs of wear or damage are present in the areas indicated, have the drive sprocket replaced by an authorized service centre.

NOTE: If you do not fully understand the correct procedure for sharpening the chain after reading the instructions that follow, have the saw chain sharpened by an authorized service centre or replace with a recommended low-kickback chain.

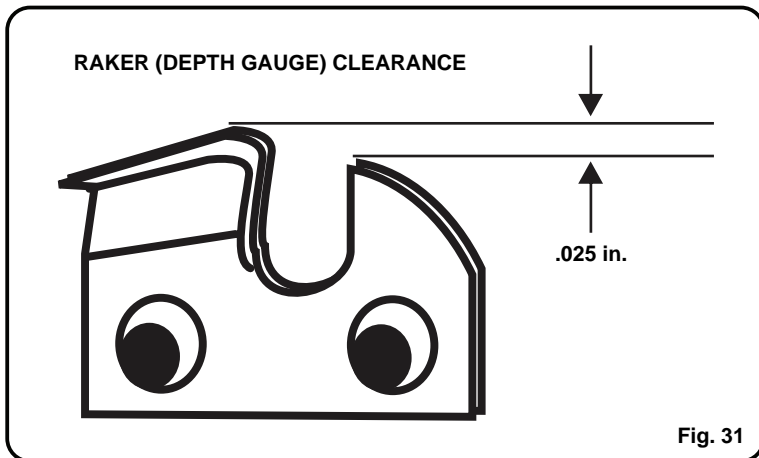

MAINTENANCE

SHARPENING THE CUTTERS (See Fig. 32 - 35.)

Be careful to file all cutters to the specified angles and to the same length, because fast cutting can only be obtained when all cutters are uniform.

CAUTION

Make sure the chainsaw is disconnected from the power supply before you work on the saw.

WARNING

The saw chain is very sharp. Always wear protective gloves when performing maintenance involving the chain to prevent serious personal injury.

- Tension the chain prior to sharpening. Refer to Adjusting The Chain Tension.
- Use a 5/32" (4 mm) diameter round file and holder. Do all of your filing at the midpoint of the bar.
- Keep the file level with the top plate of the tooth. Do not let the file dip or rock.
- Use light but firm pressure. Stroke toward the front corner of the tooth.
- Lift the file away from the steel on each return stroke.
- Put a few firm strokes on every tooth. File all left-hand cutters in one direction. Then move to the other side and file the right-hand cutters in the opposite direction.
- Remove filings from the file with a wire brush.

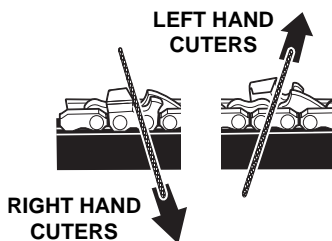
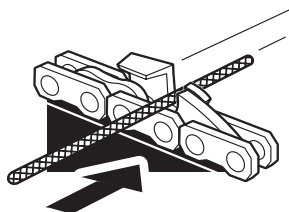
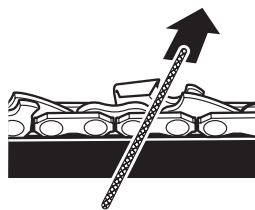
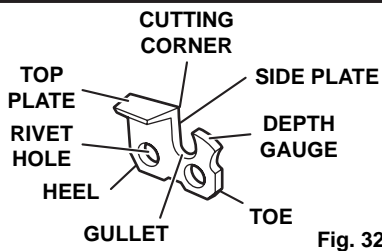

MAINTENANCE

CAUTION

A dull or improperly sharpened chain can cause excessive motor speed during cutting, which may result in severe motor damage.

WARNING

Improper chain sharpening increases the potential for kickback.

WARNING

Failure to replace or repair a damaged chain can cause serious injury.

TOP PLATE FILING ANGLE

- CORRECT 30° – file holders are marked with guide marks to align file properly to produce correct top plate angle.
- LESS THAN 30° – for cross cutting.
- MORE THAN 30° – feathered edge dulls quickly.
- Remove filings from the file with a wire brush.

SIDE PLATE ANGLE

- CORRECT 80° – Produced automatically if you use the correct diameter file in the file holder.
- HOOK – “Grabs” and dulls quickly; increases the potential for KICKBACK. Results from using a file with a diameter too small or a file held too low.
- BACKWARD SLOPE – Needs too much feed pressure; causes excessive wear to the bar and chain. Results from using a file with a diameter too large or file held too high.

MAINTENANCE

MAINTAINING DEPTH GAUGE CLEARANCE

- Maintain the depth gauge at a clearance of .025" (.6 mm). Use a depth gauge tool for checking the depth gauge clearances.
- Every time the chain is filed, check the depth gauge clearance.
- Use a flat file and a depth gauge jointer to lower all gauges uniformly. Use a .025" (.6 mm) depth gauge jointer. After lowering each depth gauge, restore original shape by rounding the front. Be careful not to damage adjoining drive links with the edge of the file.
- Depth gauges must be adjusted with the flat file in the same direction the adjoining cutter was filed with the round file. Use care not to contact cutter face with flat file when adjusting depth gauges.

MAINTAINING THE GUIDE BAR *(See Fig. 36)*

⚠ CAUTION

Make sure the chain has stopped before you do any work on the saw.

Every week of use, reverse the guide bar on the saw to distribute the wear for maximum bar life. The bar should be cleaned every day of use, and checked for wear and damage. Feathering or burring of the bar rails is a normal process of bar wear. Such faults should be smoothed with a file as soon as they occur. A bar with any of the following faults should be replaced:

- Wear inside the bar rails that permits the chain to lay over sideways
- Bent guide bar
- Cracked or broken rails
- Spread rails

Lubricate guide bars weekly with a sprocket at their tip. Using a grease syringe, lubricate weekly in the lubricating hole. Turn the guide bar and check that the lubrication holes and chain groove are free of impurities.

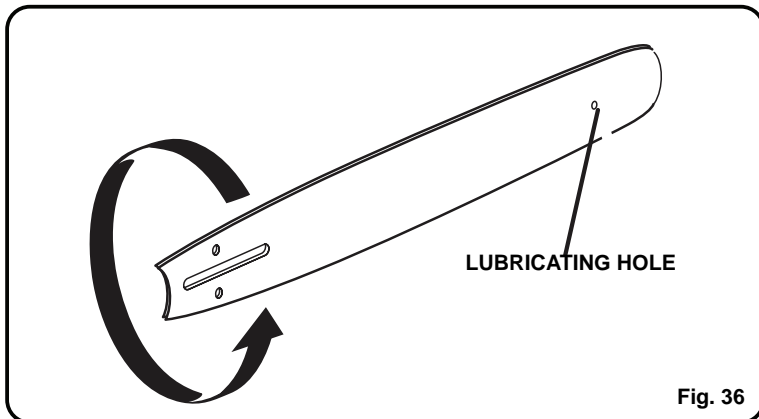

Fig. 36

MAINTENANCE

STORING THE PRODUCT

- Clean all foreign material from the product. Store it in a well-ventilated place that is inaccessible to children. Keep away from corrosive agents such as garden chemicals and de-icing salts.
- Always place the scabbard on the bar and chain before storing or transporting the chainsaw
- Use caution to avoid the sharp teeth of the chain

TROUBLESHOOTING

<u>PROBLEM</u>	<u>CAUSE</u>	<u>REMEDY</u>
Bar and chain running hot and smoking.	Check chain tension for over-tight condition. Chain-oil tank empty.	Plug in the power cord.
Motor runs, but chain is not rotating.	Chain tension too tight. Check guide bar and chain assembly. Check guide bar and chain for damage.	Retension chain, Refer to Adjusting Chain Tension earlier in this manual. Refer to Replacing Bar and Chain earlier in this manual. Inspect guide bar and chain for damage.
Motor runs, chain rotates but does not cut.	Dull chain. Chain on backwards.	Sharpen chain. Reverse direction of chain.

LIMITED FOUR-YEAR WARRANTY



GREENWORKS™ hereby warrants this product, to the original purchaser with **proof of purchase**, for a period of four (4) years against defects in materials, parts or workmanship. GREENWORKS™, at its own discretion will repair or replace any and all parts found to be defective, through normal use, free of charge to the customer. This warranty is valid only for units which have been used for personal use that have not been hired or rented for industrial/commercial use, and that have been maintained in accordance with the instructions in the owners' manual supplied with the product from new.

Battery carries a one (1) year warranty against defects in workmanship and materials. Batteries must be charged in accordance with the operator's manuals directions and regulations in order to be valid.

ITEMS NOT COVERED BY WARRANTY:

1. Any part that has become inoperative due to misuse, commercial use, abuse, neglect, accident, improper maintenance, or alteration; or
2. The unit, if it has not been operated and/or maintained in accordance with the owner's manual; or
3. Normal wear, except as noted below;
4. Routine maintenance items such as lubricants, blade sharpening;
5. Normal deterioration of the exterior finish due to use or exposure.

GREENWORKS HELPLINE (1-888-90WORKS):

Warranty service is available by calling our toll-free helpline, 9am to 5pm EST. Monday – Friday at **1-888-909-6757 (1-888-90WORKS)**.

TRANSPORTATION CHARGES:

Transportation charges for the movement of any power equipment unit or attachment are the responsibility of the purchaser. It is the purchaser's responsibility to pay transportation charges for any part submitted for replacement under this warranty unless such return is requested in writing by GREENWORKS.

PARTS

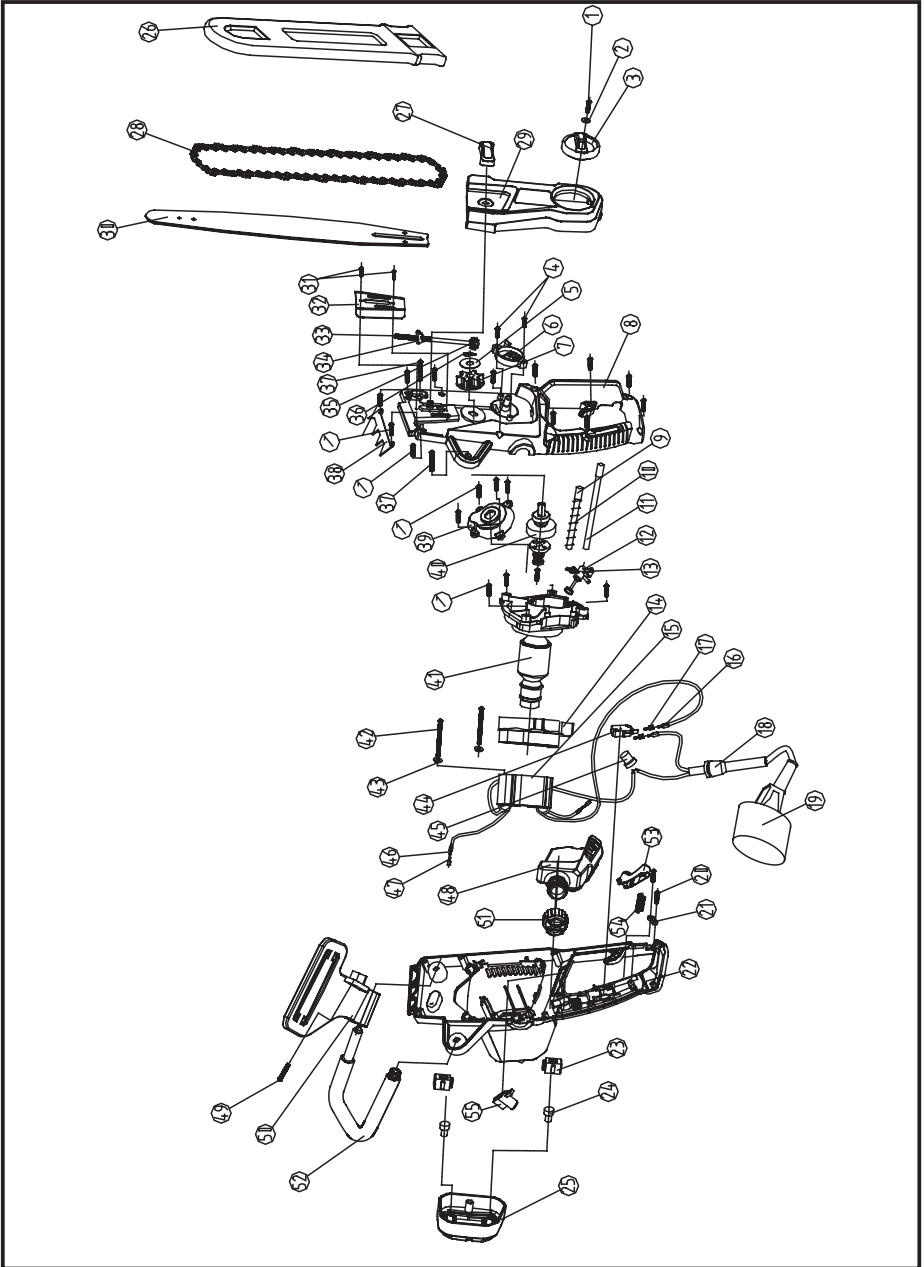

PARTS

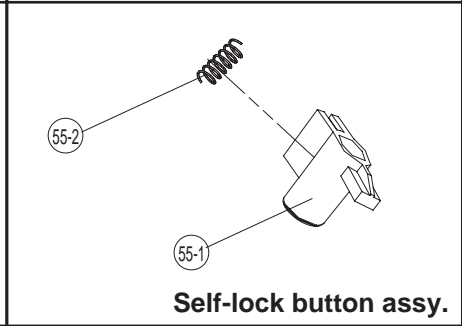
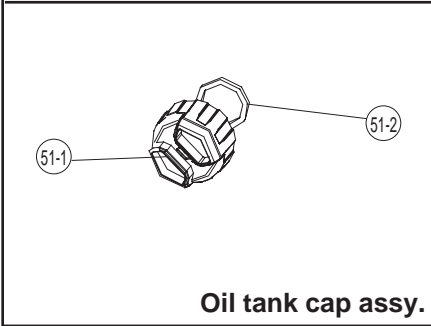
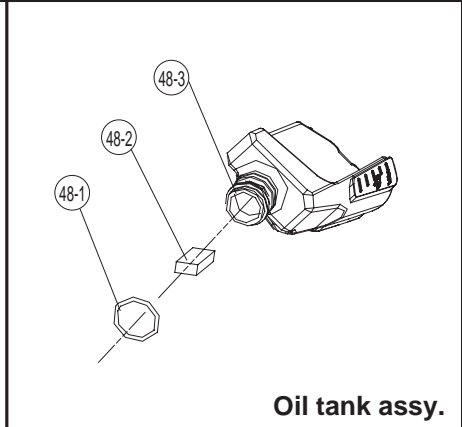
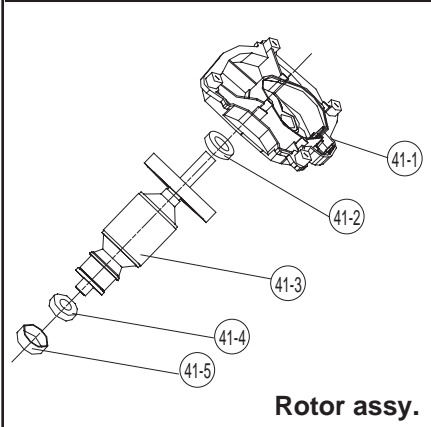
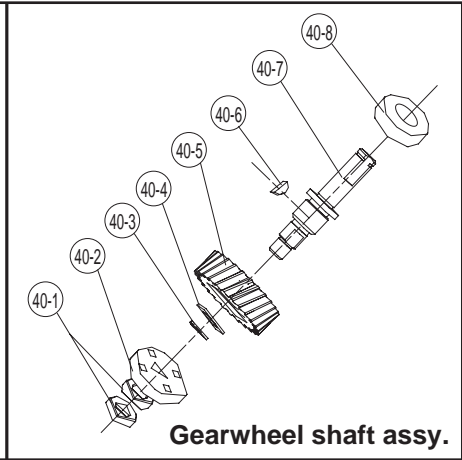
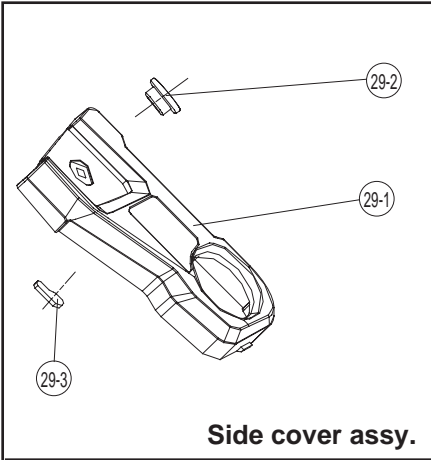

PARTS LIST

ITEM #	PART NO.	QTY	DESCRIPTION
1	3220505	23	Screw ST4×16-F
2	3290305	1	Flat washer Ø4
3	34105403-2	1	Tension knob
4	32204390	2	Screw ST4×10-F
5	33302102A	1	Washer
6	34111159	1	Tension knob borad
7	33902102A	1	Chain wheel
8	34102403-1	1	Right housing
9	34205159	1	Outlet oil tube
10	33209159	1	Outlet oil tube spring
11	34201403	1	Inlet oil tube
12	34906159	1	Oil pump assy.
13	34111403	1	Oil proof wall
14	34112403	1	Wind proof wall
15	36101403	1	Stator assy.
16	3490235	2	Straight bushing
17	36501154	2	Straight terminal
18	34203159	1	Wire sleeve
19	36401403	1	Power cord
20	3220905	2	Screw ST4×12-F
21	3410801	1W	Wire clamp
22	34101403-1	1	Left housing
23	31101403	2	Carbon brush assy.
24	34219281	2	Rubber boss
25	34113403-1	1	Rear cover
26	34148154-2	1	Sheath
27	34104403-2	1	Lock knob
28	31102154	1	16" chain
29	31102403	1	Side cover assy.
29-1	34103403	1	Side cover
29-2	33906159	1	Bushing
29-3	34205403	1	Washer
30	31201403-2	1	16" bar
31	3220203	2	Screw ST2.9×12-C
32	33301403	1R	Rubber pad
33	33203403	1	Tension gear shaft
34	33302403	1	Tension block
35	33904159	1	Tension gear
36	32901159	1R	Retaining ring Ø10

PARTS LIST

ITEM #	PART NO. Q	TY	DESCRIPTION
37	32203403	2	Screw ST4.2x42-F
38	33302159	1	Kickback parts
39	34109403	1	Upper cover (gear-box)
40	31103403	1	Gear wheel shaft assy.
40-1	32102159	2	Bearing
40-2	33901159	1	Oil pump cam
40-3	32901159	1	Retain ring
40-4	33303403	1	Washer
40-5	33202403	1	Gear wheel
40-6	32902152A	1	Half-rounded key
40-7	33201403	1	Gear wheel shaft
40-8	32104154	1	Bearing
41	31106403	1R	otor assy.
41-1	34110403	1	Lower cover (gear-box)
41-2	32103159	1B	earing
41-3	36102403	1	Rotor assembly
41-4	32104154	1	Bearing
41-5	34206159	1	Bearing sheath
42	32201403	2	Screw ST4.2x55-F
43	3290675A	2	Spring washer
44	36301154	1	Micro switch
45	3650135	1	B terminal
46	36501161	2	Staight terminal
47	34901161	2	Staight bushing
48	31104403	1	Oil tank assy.
48-1	34206329	1	O-ring
48-2	34117403	1	Sponge
48-3	34115403	1	Oil bottle
49	3220404	1	Screw ST4.2x25-F
50	34106403-1	1	Guard
51	31105403-1	1	Oil tank cap assy.
51-1	34114403-2	1	Oil tank cap
51-2	3420514A	1	Seal washer
52	34116403-1	1	Auxiliary handle
53	34107403-1	1	Switch trigger
54	33204403	1	Spring for switch trigger
55	31107403-1	1	Self-lock button assy.
55-1	34108403-1	1	Self-lock button
55-2	33205403	1	Spring for self-lock button



TOLL-FREE HELPLINE: 1-888-90WORKS (888.909.6757)

Rev: 01 (01-26-10)

 Printed in China on 100% Recycled Paper