



DASH *go*TM
unprocess your foodTM

Rapid Egg Cooker
welcome booklet



Rapid Egg Cooker

<i>Safety Information</i>	4-5
<i>What's Inside</i>	6-7
<i>Cooking Time</i>	8
<i>Using your Egg Cooker</i>	9-10
<i>Cleaning Your Egg Cooker</i>	12
<i>Troubleshooting</i>	13
<i>Specifications</i>	14
<i>Recipes</i>	15-25
<i>Customer Support</i>	22
<i>Warranty</i>	23

Important Safety Guidelines

PLEASE READ AND SAVE THIS INSTRUCTION AND CARE MANUAL

When using electrical appliances, basic safety precautions should be followed, especially the following:

- Read all instructions carefully.
- Remove all packaging and labels from appliance prior to use.
- To protect against risk of electrical shock do not put cord, plugs, or appliance in or near water or other liquid.
- Keep appliance away from children when in use.
- Only use approved ingredients with this product - other food may damage the appliance.
- Unplug from outlet when not in use, during assembly, during disassembly, and before cleaning.
- Avoid contact with heating parts.
- Do not operate this appliance with a damaged cord, damaged plug, after the appliance malfunctions, is dropped, or damaged in any manner.
- Any maintenance other than cleaning, please contact StoreBound by phone at 1-800-898-6970 from 7AM - 7PM PST Monday - Friday or by email at info@storebound.com.
- Use only Egg Cooker attachments recommended or sold by StoreBound. Others may result in fire, electric shock, or injury.
- Do not use outdoors.
- Do not let the cord hang over edge of table, hang over the sink, or touch hot surfaces.
- Only use the Egg Cooker on a stable surface.
- Make sure the Egg Cooker is off before removing eggs.
- Do not put your hands or other objects into the Egg Cooker while it is in operation. If food spills on the

heating platform, make sure Egg Cooker is turned off and cool before cleaning.

- Keep hands and utensils away from heating platform while cooking eggs to reduce the risk of injury or damage to the Egg Cooker.
- Internal base and contents (water and eggs) of Egg Cooker are hot when in use. Let cool before handling and/or cleaning.
- Do not place on or near a hot gas burner, hot electric burner, or in a heated oven.
- Use extreme caution when handling the Measuring Cup as it contains a sharp pin on the bottom of the cup which may cause injury.
- When cleaning the body do not submerge in any liquid. Instead use a soft wet cloth to wipe down.
- Plastic dome Lid gets hot; do not touch while eggs are cooking. Let cool before touching.
- Be certain Lid is securely in place before engaging appliance.
- Do not open Lid when Egg Cooker is cooking.
- Do not put the appliance in the refrigerator.
- Do not use expired eggs, expired egg whites, or expired liquid eggs.



Parts & Features

1. Cover Handle
2. Steamer Hole
3. Lid
4. Egg Poacher
5. Egg Tray Handle
6. Egg Bowl
7. Egg Tray
8. Measuring Cup
9. Pin
10. Body
11. Plug

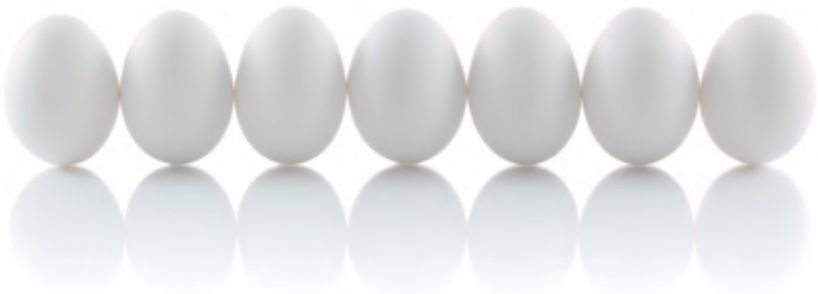

What's Inside

welcome booklet

7

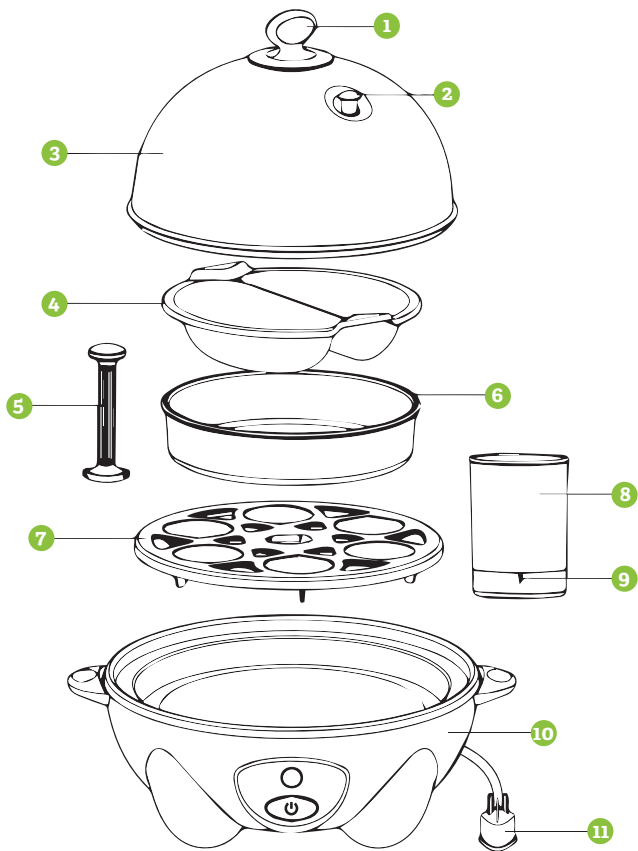

Soft, medium and hard-boiled eggs

The following time guidelines are for Large eggs. Extra Large or Jumbo eggs may require additional time in the cooker to achieve the desired results.

If you like your eggs a little more firm, let them sit covered in the Egg Cooker for a few minutes more.

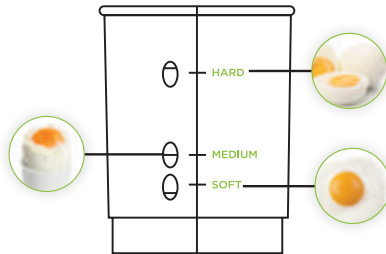

If you want completely hard boiled eggs, let them sit for an extra 5 minutes after the automatic shutoff.

Style	Quantity	Time
Soft-Boiled	1-6 eggs	6 minutes
Medium Egg	1-6 eggs	7 minutes
Hard-Boiled	1-6 eggs	12 minutes

Directions

The Egg Cooker will automatically turn on when plugged in and will turn off after all the water has evaporated from the Heating Plate.

1. Remove the Lid.
2. Use the Measuring Cup to place the appropriate amount of clean water into the Egg Cooker.
3. Pierce the **larger end of each egg** with the pin attached to the bottom of the Measuring Cup.
4. Attach the Egg Tray handle to the Egg Tray. Place an egg in each designated spot in the Egg Tray.
5. Make sure that the holes in the larger end of the eggs are pointed upwards. Do not let the eggs touch the Heating Plate.
6. Cover with the Lid and plug Egg Cooker in.
7. When the light turns off, the eggs will be cooked. Actual cooking time will depend on number of eggs and desired consistency (see Cooking Time).
8. Remove eggs after the automatic shut off.
9. Run cool water over the eggs before eating them.

Enjoy your eggs!

Poached eggs:

1. Fill the Measuring Cup with cold water to the Medium line.
2. Pour cold water into the Heating Plate (in the body of the Egg Cooker.)
3. Place Egg Tray on the body and place Egg Poaching Tray on top of the Egg Tray.
4. Break an egg into each poaching section.
5. Cover the Lid and plug Egg Cooker in.
6. When the light turns off, the eggs will be poached. Remove eggs immediately.

Omelette:

1. Fill the Measuring Cup with cold water to the Medium Line.
2. Pour cold water into the Heating Plate.
3. Place Egg Tray on the body and place Egg Bowl on top of the Egg Tray.
4. Mix eggs in a bowl before pouring into Egg Bowl.
5. Cover the Lid and plug Egg Cooker in.
6. When the light turns off, the omelette will be cooked. For a dry omelette, leave the eggs in the cooker for an additional two minutes.



health fact!

*Did you know that egg whites are a great source of protein?
It's true!*

CAUTION: During and after use, the Egg Cooker is hot.

Do not attempt to clean your Egg Cooker until the appliance has cooled. Do not submerge the main body in any liquid.

Your Egg Cooker is not dishwasher safe.

1. Before cleaning or moving the appliance, make sure to unplug the Egg Cooker.
2. Wipe down the main body and Heating Plate with a wet cloth.
3. Wash the attachments and Lid in the sink with hot, soapy water.

Although your Egg Cooker is simple to use and durable, please refer to the following list if problems occur:

1. The power light does not turn on.

- Ensure that the power cord is plugged into the power outlet
- Check to make sure the power outlet is operating correctly.
- Press the power button (located on the front of your Egg Cooker.)
- Determine if a power failure has occurred in your home, apartment or building.

2. The eggs are over or under cooked.

- Use the Measuring Cup to place the appropriate amount of water in your Egg Cooker. Refer to the section, “Using Your Egg Cooker.”
- Refer to the section “Cooking Time” and observe the recommended cooking times for Soft/Runny, Medium or Hard Boiled eggs.

If your problem is not resolved in the instructions listed, please contact StoreBound by phone at 1-800-898-6970 from 7AM - 7PM PST Monday - Friday, or by email at info@storebound.com.

Description	Dash Go Egg Cooker
Model	DEC005 Series
Rated Voltage	120v ~
Rated Frequency	60Hz
Rated Power	360Watts
Egg Capacity	6 Eggs
Dimensions	7.36" x 6.29" x 6.29"



Stock#: REC-062013V3



RECIPES

EGGCELLENT IDEAS

DEVILED EGGS



INGREDIENTS

7 hard-boiled eggs, cooled
3 tbsp mayonnaise
1 tbsp Dijon-style mustard

$\frac{1}{8}$ tsp salt
3-5 drops hot sauce
dash of paprika, chives and dill

DIRECTIONS

Remove shells from fully cooked eggs. Cut each egg in half. Remove yolks. Put egg yolks in a large bowl and break up the yolks.

Mix in mayonnaise, mustard, salt, and hot sauce. Spoon the mixture into the egg whites. Place the eggs into the refrigerator until ready to serve. Just before serving, sprinkle on a dash of paprika, chives and dill.

Get eggcited for some devilish treats!



EGGS BENEDICT**INGREDIENTS**

4 egg yolks
3½ tbsp lemon juice
1 pinch ground white pepper
¼ tsp Worcestershire sauce
1 tbsp water
1 cup butter, melted
pinch of salt

4 eggs
fresh asparagus
4 strips Canadian-style bacon
2 english muffins cut in half
2 tbsp butter, softened
chives or cayenne pepper



DIRECTIONS

HOLLANDAISE SAUCE

On the stovetop, fill the bottom of a double boiler part-way with water. Make sure that water does not touch the bottom of the bowl. Bring water to a gentle simmer.

In the top of the double boiler, whisk together egg yolks, lemon juice, white pepper, Worcestershire sauce, and 1 tablespoon water. Add the melted butter to egg yolk mixture 1 or 2 tablespoons at a time while whisking yolks constantly.

If hollandaise begins to get too thick, add a teaspoon or two of hot water. Continue whisking until incorporated. Whisk in salt then remove from heat. Place a Lid on pan to keep sauce warm.



DIRECTIONS CONTINUED...

Fill the Measuring Cup with cold water to the Medium 1-3 eggs line. Pour cold water onto Heating Plate. Place Egg Tray on base and place lightly greased poaching tray on top of the Egg Tray. Break an egg into each poaching section.

Replace the Lid and turn the Egg Cooker on. When buzzer sounds the eggs will be poached. Remove eggs immediately to prevent overcooking. Repeat for desired amount of eggs.

Butter english muffin. Place bottom of english muffin half on plate, place Canadian-style bacon, asparagus, 1 poached egg, a spoonful of hollandaise sauce then garnish with chives or cayenne pepper (optional).



EGG SALAD



INGREDIENTS

7 hard-boiled eggs, cooled
½ stalk celery
⅓ cup mayonnaise

2 tablespoons Dijon-style mustard
¼ tablespoon salt
⅛ teaspoons black pepper

DIRECTIONS

Remove shells from fully cooked eggs. Cut the eggs into quarters. Cut the celery into a small dice. Mix the eggs and the celery together. Add mayonnaise, mustard, salt, and pepper. Mix until desired texture is reached.

Enjoy your eggcellent salad!



chef tip!

For a healthy twist, you can make this egg salad with half the egg-yolks and light, or olive-oil based mayonnaise.

HEALTHY OMELETTE



INGREDIENTS

2 egg whites
1 whole egg
cooked green beans or asparagus

¼ cup Parmesan or pecorino cheese
salt & pepper
lettuce & tomato to garnish

DIRECTIONS

Beat 2 egg whites and 1 whole egg together. Pour into omelette tray.

Add cooked green beans or asparagus and let cook according to instructions on page 9. Before serving, sprinkle with Parmesan and season with salt & pepper to taste.



chef tip!

Bulking up the volume of the omelette with egg whites is a great way to cut calories but still make a sizable portion.

If your device fails to function as required, please check the troubleshooting checklist on bydash.com. There may only be a minor problem that you can solve yourself.

For product support, warranty and maintenance related questions (other than cleaning) please contact StoreBound directly at: 1-800-898-6970 from 7AM - 7PM PST, Monday - Friday, or by email at info@storebound.com.

REPAIRS

DANGER! Risk of electric shock! The Dash Go Rapid Egg Cooker is an electrical appliance. Do not attempt to repair the appliance yourself under any circumstances.

Contact customer service regarding repairs to the device.

Warranty

welcome booklet

27



STOREBOUND, LLC, - 1 YEAR LIMITED WARRANTY

Your Storebound product is warranted to be free from defects in material and workmanship for a period of one (1) year from the date of the original purchase when utilized for normal and intended household use. Should any defect covered by the terms of the limited warranty be discovered within one (1) year, StoreBound LLC will repair or replace or replace the defective part. To process a warranty claim, contact customer care agent at 1-800-898-6970 for further assistance and instruction. A customer care agent will conduct troubleshooting in an attempt to fix any minor problems. If troubleshooting fails to fix the problem, a return authorization will be issued. Proof of purchase indicating date and place of purchase is required and should accompany the return. You must also include your full name, shipping address, and telephone number. We are unable to ship returns to a PO Box. Storebound will be responsible for delays or unprocessed claims resulting from a purchaser's failure to provide any or all of the necessary information. Freight costs must be prepaid by the purchaser.

Send all Inquires to: info@storebound.com

There are no express warranties except as listed above

REPAIR OR REPLACEMENT AS PROVIDED UNDER THIS WARRANTY IS THE EXCLUSIVE REMEDY OF THE CUSTOMER. STOREBOUND SHALL NOT BE LIABLE FOR ANY INCIDENTAL OR CONSEQUENTIAL DAMAGES FOR BREACH OF ANY EXPRESS OR IMPLIED WARRANTY ON THIS PRODUCT EXCEPT TO THE EXTENT PROHIBITED BY APPLICABLE LAW. ANY IMPLIED WARRANTY OF MERCHANTABILITY OR FITNESS FOR A PARTICULAR PURPOSE ON THIS PRODUCT IS LIMITED IN DURATION TO THE DURATION OF THIS WARRANTY.

Some states do not allow the exclusion or limitation of incidental or consequential damages, or limitations on how long an implied warranty lasts, so the above exclusions or limitations may not apply to you. This warranty gives you specific legal rights and you may also have other rights, which vary from state to state.

Evan Dash, CEO

A handwritten signature in black ink that reads "Evan Dash".



*Please visit bydash.com
Customer Support 1-800-898-6970*