

ITEM #0402068

DINING TABLE

MODEL #S-1335T

allen + roth® is a registered trademark of LF, LLC. All Rights Reserved.

Français p. 7
Español p. 13

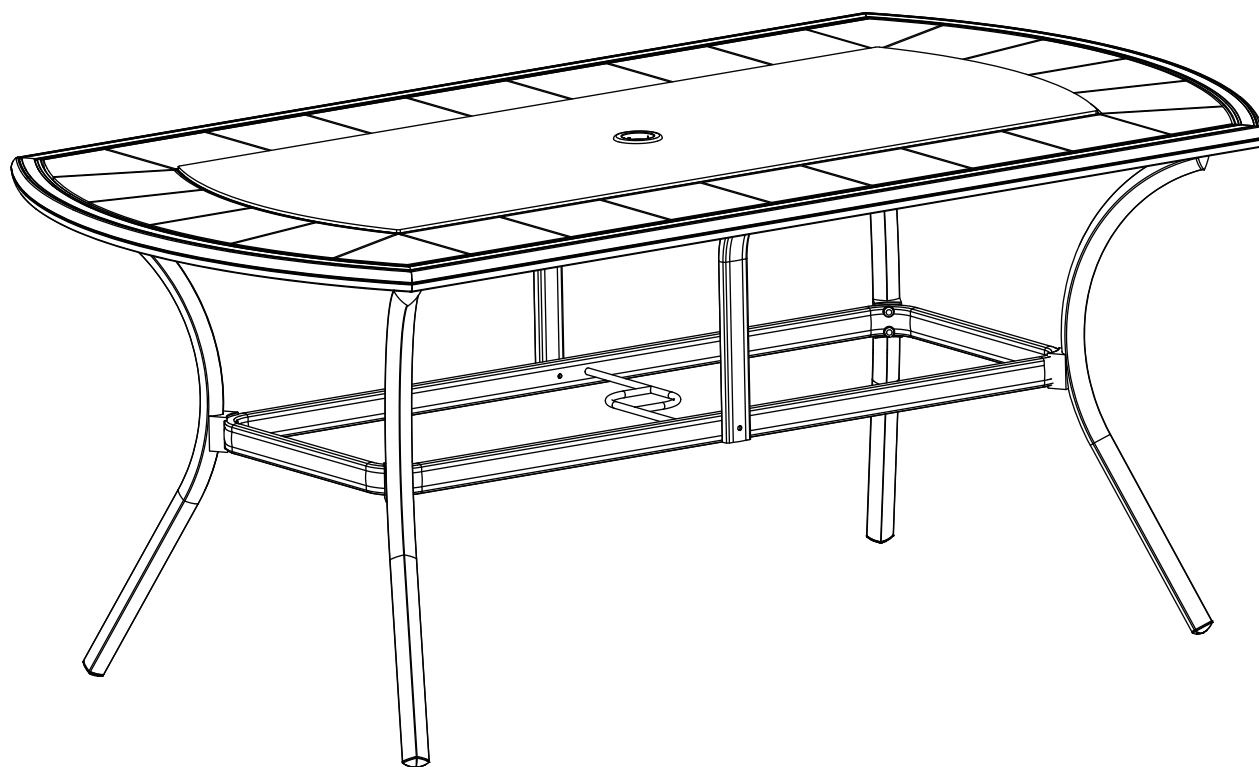

ATTACH YOUR RECEIPT HERE

Serial Number _____ Purchase Date _____



Questions, problems, missing parts? Before returning to your retailer, call our customer service department at 1-866-439-9800, 8 a.m. - 8 p.m., EST, Monday - Friday.

XXXXXX

PACKAGE CONTENTS

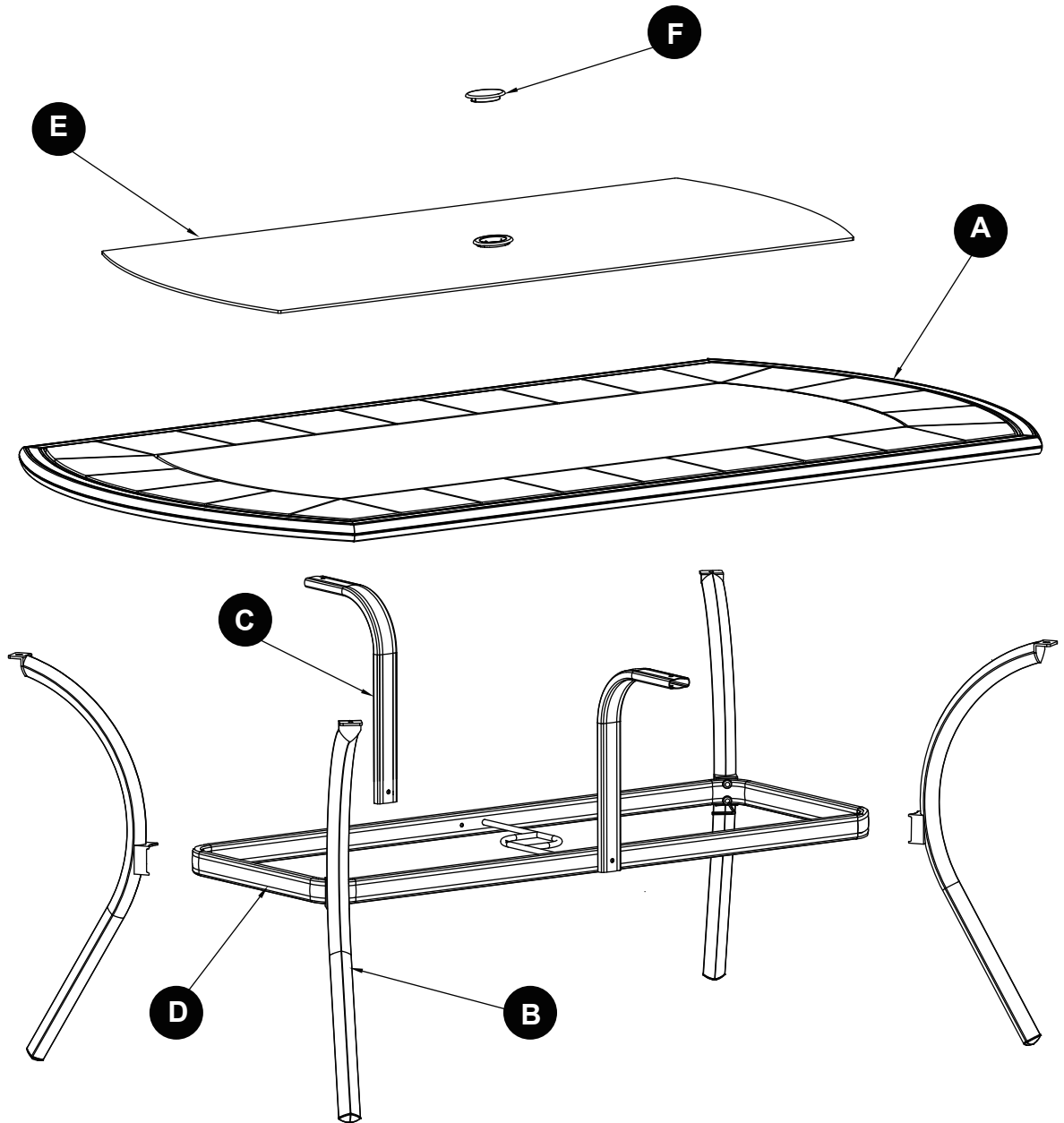

PART	DESCRIPTION	QUANTITY
A	Slate Table Top	1
B	Table Legs	4
C	Top Strut	2
D	Body Ring	1
E	Glass Top	1
F	Glass Top Cap	1

HARDWARE CONTENTS

AA



Long bolt
Qty.8

BB

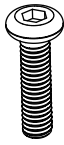

Medium bolt
Qty.4

CC

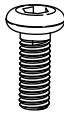

Short bolt
Qty.4

DD

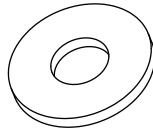

Big Washer
Qty.4

EE

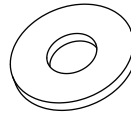

Small
Washer
Qty.12

FF

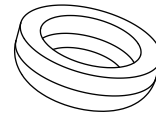

Bolt Cap
Qty.12

GG

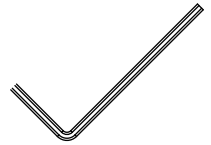

Allen Key
Qty.1

SAFETY INFORMATION

Please read and understand this entire manual before attempting to assemble, operate or install the product.

CAUTION

- Assemble on a soft, non-abrasive surface.
- Don't fully fasten the bolts until all bolts are in place.
- Changes or modifications not approved by the party responsible for compliance could void the user's authority to operate the equipment.

PREPARATION

Before beginning assembly of product, make sure all parts are present. Compare parts with package contents list and hardware contents list. If any part is missing or damaged, do not attempt to assemble the product.



Estimated Assembly Time: 30 minutes

Tools Required for Assembly: Allen key (included).

ASSEMBLY INSTRUCTIONS



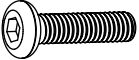

1. Attach the table legs (B) and the top struts (C) to the body ring (D) with the long bolts (AA) and the medium bolts (BB) through small washers (EE) using the Allen Key (GG). When all the bolts are in place, tighten them fully and cover the bolts with bolt caps (FF).

Hardware Used

AA	Long bolt		x 8
BB	Medium bolt		x 2
EE	Small Washer		x 10
FF	Bolt Cap		x 10

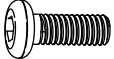
2. Place the slate table top (A) face down on a non-abrasive surface. Attach the table leg assembly using bolts. For the table legs (B), use short bolts (CC) and big washers (DD). For the table struts (C), use medium bolts (BB) and small washers (EE). When all bolts are in place, tighten fully. Cover the medium bolts (BB) with bolts caps (FF).

Hardware Used

BB	Medium bolt		x 2
CC	Short bolt		x 4
DD	Big Washer		x 4
EE	Small Washer		x 2
FF	Bolt Cap		x 2

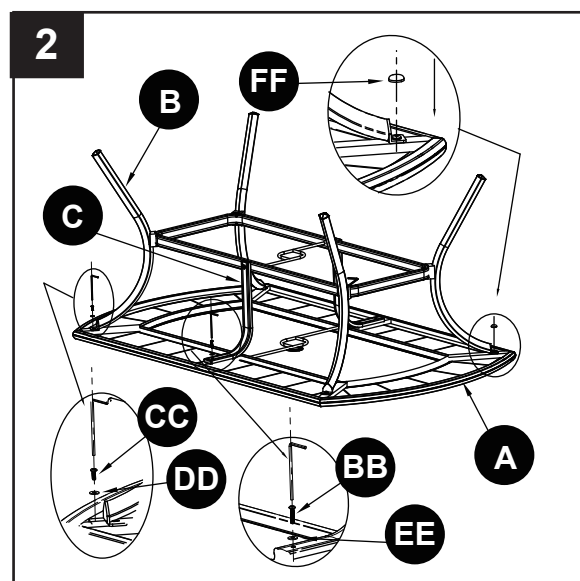
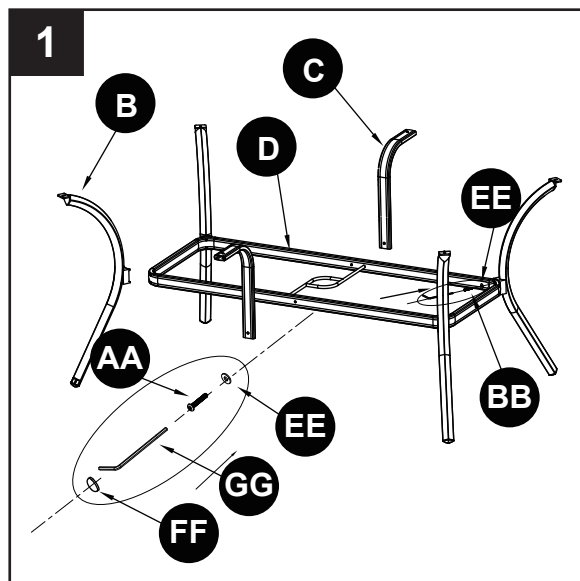

3. Place the glass top (E) with the smooth surface facing upward on the slate table top (A). Fix the glass top cap (F) through the central hole.

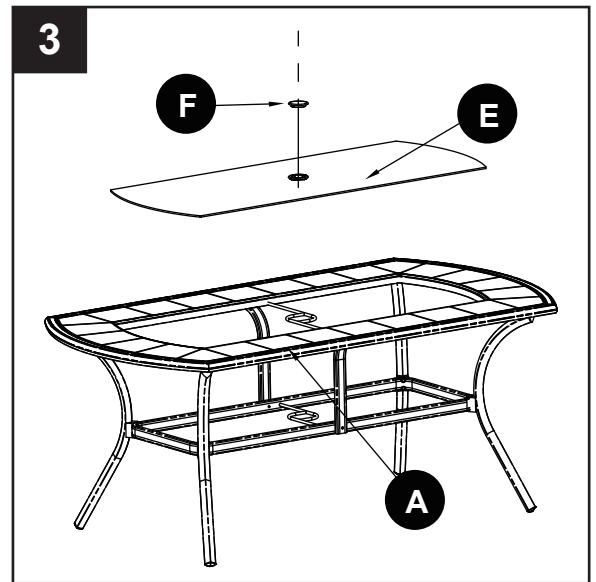

CARE AND MAINTENANCE

- Immediately remove any spot or stain.
- To clean, wash with a mild soap, rinse with water and let air dry.
- Do not use strong solvents or bleach as they may damage the surface.
- Use an outdoor cover to extend the life of your table.

LIMITED WARRANTY







This warranty is for the original purchaser and applies to defects in materials and workmanship of your patio furniture, provided your unit is maintained with care and used only for personal, residential purposes.

Frames are warranted to be free from defects in material or workmanship for five (5) years.

Exclusions: Items used for commercial, contract or other non-residential purposes, display models, items purchased "as is," or items damaged due to acts of nature, vandalism, misuse or improper assembly are not covered. Discoloration or fading of the finish or fabrics as a result of exposure to the elements, chemicals or spills is not covered. Tabletop breakage, corrosion or rusting of hardware and damages to frames or welds caused by improper assembly, misuse or natural causes are not covered.

For warranty service, call our customer service department at 1-866-439-9800, 8 a.m. - 8 p.m., EST, Monday - Friday.

REPLACEMENT PARTS LIST

PART	DESCRIPTION	PAPT#	
AA	Long Bolt	HW0002B	
BB	Medium Bolt	HW0003B	
CC	Short Bolt	HW0004B	
DD	Big Washer	HW0007W	
EE	Small Washer	HW0006W	
FF	Bolt cap	HW0008C	
GG	Allen Key	HW0009A	

Printed in China

allen + roth® is a registered trademark of LF, LLC. All Rights Reserved.