

REFRIGERATOR USER INSTRUCTIONS

THANK YOU for purchasing this high-quality product. If you should experience a problem not covered in TROUBLESHOOTING, please visit our website at www.kitchenaid.com for additional information. If you still need assistance, call us at 1-800-422-1230. In Canada, visit our website at www.kitchenaid.ca or call us at 1-800-807-6777.

You will need your model and serial number, located on the inside wall of the refrigerator compartment.

Para obtener acceso a “Instrucciones para el usuario del refrigerador” en español, o para obtener información adicional acerca de su producto, visite: www.kitchenaid.com.

Necesitará su número de modelo y de serie, ubicado en el interior del compartimiento del refrigerador.

Table of Contents / Table des matières

REFRIGERATOR SAFETY	2	SÉCURITÉ DU RÉFRIGÉRATEUR	26
Proper Disposal of Your Old Refrigerator	2	Mise au rebut adéquate de votre vieux réfrigérateur	27
INSTALLATION INSTRUCTIONS	3	INSTRUCTIONS D'INSTALLATION	27
Unpack the Refrigerator	3	Déballage du réfrigérateur	27
Location Requirements	3	Exigences d'emplacement	28
Remove and Replace Refrigerator Doors and Drawer Front	4	Retrait et réinstallation des portes du réfrigérateur et de l'avant du tiroir	28
Electrical Requirements	6	Spécifications électriques	31
Water Supply Requirements	6	Spécifications de l'alimentation en eau	31
Connect the Water Supply	6	Raccordement à l'alimentation en eau	31
Handle Installation and Removal	8	Installation et démontage des poignées	33
Door Closing and Door Alignment	9	Fermeture et alignement de la porte	34
FILTERS AND ACCESSORIES	9	FILTRES ET ACCESSOIRES	35
Water Filtration System	9	Système de filtration de l'eau	35
Install Air Filter	10	Installation du filtre à air	35
Install Produce Preserver	10	Installation du conservateur pour produits frais	36
Accessories	11	Accessoires	37
REFRIGERATOR USE	11	UTILISATION DU RÉFRIGÉRATEUR	37
Opening and Closing Doors	11	Ouverture et fermeture des portes	37
Using the Controls	12	Utilisation des commandes	37
Water Dispenser	13	Distributeur d'eau	39
Ice Maker	13	Machine à glaçons	40
REFRIGERATOR FEATURES	14	CARACTÉRISTIQUES DU RÉFRIGÉRATEUR	40
Refrigerator Shelves	14	Tablettes du réfrigérateur	40
Pantry Drawer	14	Garde-manger	41
Crisper	15	Bac à légumes	41
DOOR FEATURES	15	CARACTÉRISTIQUES DE LA PORTE	42
Condiment Bins	15	Balconnets à condiments	42
Fresh Bin	15	Balconnet fraîcheur	42
Half-Height Bin	16	Balconnet mi-hauteur	42
REFRIGERATOR CARE	16	ENTRETIEN DU RÉFRIGÉRATEUR	42
Cleaning	16	Nettoyage	42
Changing the Light Bulbs	16	Remplacement des ampoules d'éclairage	43
Vacation and Moving Care	17	Entretien avant les vacances ou lors d'un déménagement	43
TROUBLESHOOTING	18	DÉPANNAGE	44
WATER FILTER CERTIFICATIONS	23	FEUILLE DE DONNÉES SUR LA PERFORMANCE	50
PERFORMANCE DATA SHEET	24	GARANTIE	51
WARRANTY	25		

REFRIGERATOR SAFETY

Your safety and the safety of others are very important.

We have provided many important safety messages in this manual and on your appliance. Always read and obey all safety messages.



This is the safety alert symbol.

This symbol alerts you to potential hazards that can kill or hurt you and others.

All safety messages will follow the safety alert symbol and either the word "DANGER" or "WARNING."

These words mean:

⚠ DANGER

You can be killed or seriously injured if you don't immediately follow instructions.

⚠ WARNING

You can be killed or seriously injured if you don't follow instructions.

All safety messages will tell you what the potential hazard is, tell you how to reduce the chance of injury, and tell you what can happen if the instructions are not followed.

IMPORTANT SAFETY INSTRUCTIONS

WARNING: To reduce the risk of fire, electric shock, or injury when using your refrigerator, follow these basic precautions:

- Plug into a grounded 3 prong outlet.
- Do not remove ground prong.
- Do not use an adapter.
- Do not use an extension cord.
- Disconnect power before servicing.
- Replace all parts and panels before operating.
- Remove doors from your old refrigerator.
- Use nonflammable cleaner.
- Keep flammable materials and vapors, such as gasoline, away from refrigerator.
- Use two or more people to move and install refrigerator.
- Disconnect power before installing ice maker (on ice maker kit ready models only).
- Use a sturdy glass when dispensing ice (on some models).
- Do not hit the refrigerator glass doors (on some models).

SAVE THESE INSTRUCTIONS

State of California Proposition 65 Warnings:

WARNING: This product contains one or more chemicals known to the State of California to cause cancer.

WARNING: This product contains one or more chemicals known to the State of California to cause birth defects or other reproductive harm.

Proper Disposal of Your Old Refrigerator

⚠ WARNING

Suffocation Hazard

Remove doors from your old refrigerator.

Failure to do so can result in death or brain damage.

IMPORTANT: Child entrapment and suffocation are not problems of the past. Junked or abandoned refrigerators are still dangerous – even if they will sit for "just a few days." If you are getting rid of your old refrigerator, please follow these instructions to help prevent accidents.

Before You Throw Away Your Old Refrigerator or Freezer:

- Take off the doors.
- Leave the shelves in place so that children may not easily climb inside.

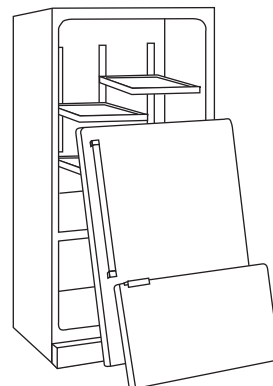

Important information to know about disposal of refrigerants:

Dispose of refrigerator in accordance with Federal and Local regulations. Refrigerants must be evacuated by a licensed, EPA certified refrigerant technician in accordance with established procedures.

INSTALLATION INSTRUCTIONS

Unpack the Refrigerator

⚠️ WARNING

Excessive Weight Hazard

Use two or more people to move and install refrigerator.

Failure to do so can result in back or other injury.

Remove the Packaging

- Remove tape and glue residue from surfaces before turning on the refrigerator. Rub a small amount of liquid dish soap over the adhesive with your fingers. Wipe with warm water and dry.
- Do not use sharp instruments, rubbing alcohol, flammable fluids, or abrasive cleaners to remove tape or glue. These products can damage the surface of your refrigerator. For more information, see “Refrigerator Safety.”
- Dispose of/recycle all packaging materials.

When Moving Your Refrigerator:

Your refrigerator is heavy. When moving the refrigerator for cleaning or service, be sure to cover the floor with cardboard or hardboard to avoid floor damage. Always pull the refrigerator straight out when moving it. Do not wiggle or “walk” the refrigerator when trying to move it, as floor damage could occur.

Clean Before Using

After you remove all of the packaging materials, clean the inside of your refrigerator before using it. See the cleaning instructions in “Refrigerator Care.”

Important information to know about glass shelves and covers:

Do not clean glass shelves or covers with warm water when they are cold. Shelves and covers may break if exposed to sudden temperature changes or impact, such as bumping. Tempered glass is designed to shatter into many small, pebble-size pieces. This is normal. Glass shelves and covers are heavy. Use both hands when removing them to avoid dropping.

Location Requirements

⚠️ WARNING



Explosion Hazard

Keep flammable materials and vapors, such as gasoline, away from refrigerator.

Failure to do so can result in death, explosion, or fire.

To ensure proper ventilation for your refrigerator, allow for a ½" (1.25 cm) of space on each side and at the top. Allow for a 1" (2.54 cm) space behind the refrigerator. If your refrigerator has an ice maker, allow extra space at the back for the water line connections. When installing your refrigerator next to a fixed wall, leave a 2" (5.08 cm) minimum space between the refrigerator and wall to allow the door to swing open.

NOTE: This refrigerator is intended for use in a location where the temperature ranges from a minimum of 55°F (13°C) to a maximum of 110°F (43°C). The preferred room temperature range for optimum performance, which reduces electricity usage and provides superior cooling, is between 60°F (15°C) and 90°F (32°C). It is recommended that you do not install the refrigerator near a heat source, such as an oven or radiator.

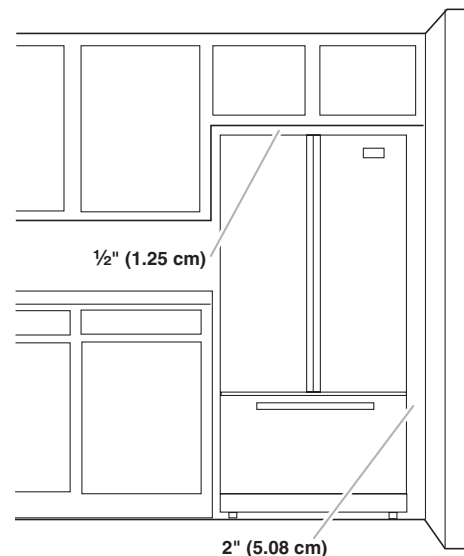

Remove and Replace Refrigerator Doors and Drawer Front

Depending on the width of your door opening, it may be necessary to remove the refrigerator doors to move the refrigerator into your home.

IMPORTANT:

- If the refrigerator was previously installed and you are moving it out of the home, before you begin, turn the refrigerator control OFF, and unplug the refrigerator or disconnect power. Remove food and any adjustable door or utility bins from doors.
- Keep the refrigerator doors closed until you are ready to lift them free from the cabinet. Provide additional support for the refrigerator door while the hinges are being removed. Do not depend on the door gasket magnets to hold the door in place while you are working.
- All graphics referenced in the following instructions are included later in this section after "Final Steps."

TOOLS NEEDED: 5/16", 3/8", and 1/4" hex head socket wrenches, Torx®† T25 screwdriver, #2 Phillips screwdriver, and a flat-blade screwdriver.

Remove Doors and Hinges

1. Unplug refrigerator or disconnect power.
 2. Remove the base grille. Grasp the grille firmly and pull it toward you.
 3. Starting with the right-hand side door, remove the parts for the top hinge as shown in Top Hinge graphic. Lift the refrigerator door from the bottom hinge pin.
 4. Remove the hinge pin cover from the bottom hinge pin and keep it for later use. See Bottom Hinge graphic.
 5. Remove top hinge cover from left-hand side refrigerator door.
 6. Remove the parts for the top hinge as shown in Top Hinge graphic. Lift the left-hand side door from the bottom hinge pin.
- NOTE:** On some models, remove the hinge pin cover from the bottom hinge pin and keep it for later use. See Bottom Hinge graphic.

Replace Doors and Hinges

1. Assemble the parts for the top hinges as shown in Top Hinge graphic. Do not tighten the screws completely.
 2. Replace the parts for the bottom hinge as shown in Bottom Hinge graphic. Tighten screws. Replace the refrigerator door.
- NOTE:** Provide additional support for the refrigerator door while the hinges are being moved. Do not depend on the door gasket magnets to hold the door in place while you are working.
3. Align the door so that the bottom of the refrigerator doors align evenly with the top of the freezer drawer. Tighten all screws.
 4. Replace the top hinge covers.

Remove and Replace Freezer Drawer Front

IMPORTANT: Two people may be required to remove and replace the freezer drawer. Graphics are included later in this section.

To remove drawer front:

1. Open the freezer drawer to full extension.
 2. Loosen the four screws attaching the drawer glides to the drawer front. See Drawer Front Removal graphic.
- NOTE:** Loosen screws three to four turns. Keep the screws in the drawer front.
3. Lift drawer front upward and off the screws. See Drawer Front Removal graphic.

4. The refrigerator leveling/roller assembly protrudes from each side of the cabinet base. Remove the three screws attaching each assembly, and remove the assemblies. See Refrigerator Leveling/Roller Assembly graphic.

To replace drawer front:

1. Align the leveling/roller assembly with the holes on each side of the refrigerator cabinet. Using the screws removed, reinstall the assemblies to the cabinet base. Tighten the screws completely.
2. Slide the drawer glides out of the freezer compartment. Insert the screws in the top of the drawer front into the slots in the drawer brackets. See Drawer Front Replacement graphic.
3. Pull the drawer brackets toward you to position the two screws in the bottom of the drawer front into the brackets and completely tighten the four screws. See Drawer Front Replacement graphic.
4. Replace the base grille.
 - Pull open the freezer drawer.
 - Align the three clips on the back of the base grille with the three tabs at the base of the refrigerator.
 - Push the base grille in toward the refrigerator until it is firmly in place.

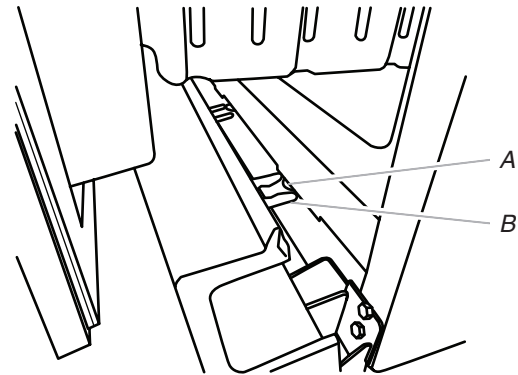

A. Tab
B. Clip

Final Steps

! WARNING



Electrical Shock Hazard

Plug into a grounded 3 prong outlet.

Do not remove ground prong.

Do not use an adapter.

Do not use an extension cord.

Failure to follow these instructions can result in death, fire, or electrical shock.

1. Plug into a grounded 3 prong outlet.
2. Return all removable parts to doors and drawer and food to refrigerator and freezer.

†@TORX is a registered trademark of Acument Intellectual Properties, LLC.

Door Removal and Replacement

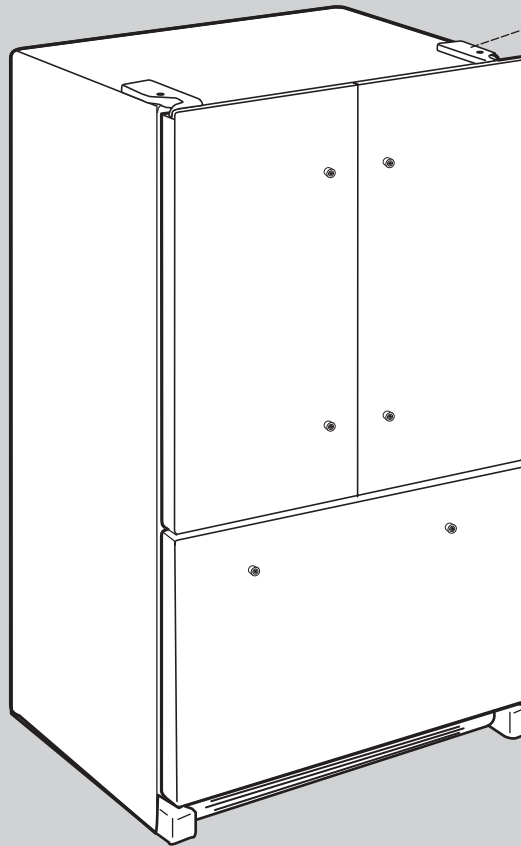

Top Hinges

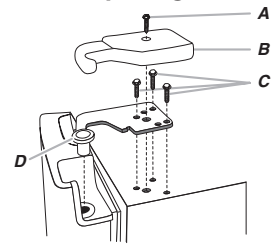

- A. Hinge Cover Screw
- B. Top Hinge Cover
- C. $\frac{5}{16}$ " Hex-Head Hinge Screws
- D. Top Hinge

Bottom Hinges

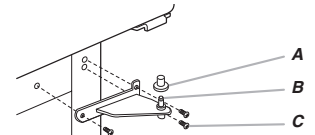

- A. Hinge Pin Cover
- B. Bottom Hinge
- C. Hinge Screws

Leveling/Roller Assembly

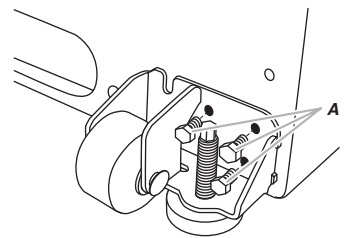

- A. Assembly Screws

Drawer Front Removal

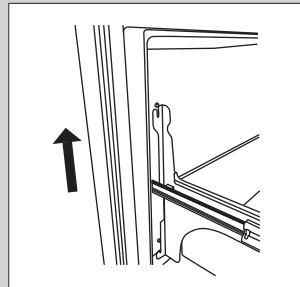
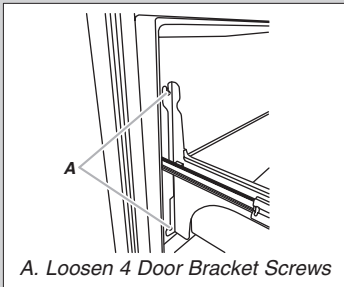

Drawer Front Replacement

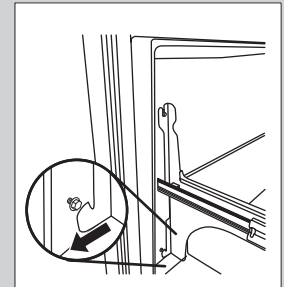
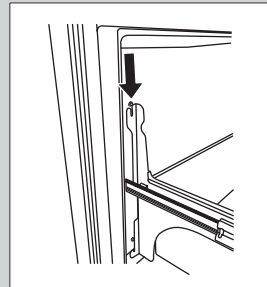

Electrical Requirements

⚠ WARNING



Electrical Shock Hazard

Plug into a grounded 3 prong outlet.

Do not remove ground prong.

Do not use an adapter.

Do not use an extension cord.

Failure to follow these instructions can result in death, fire, or electrical shock.

Before you move your refrigerator into its final location, it is important to make sure you have the proper electrical connection.

Recommended Grounding Method

A 115 volt, 60 Hz., AC only 15- or 20-amp fused, grounded electrical supply is required. It is recommended that a separate circuit serving only your refrigerator be provided. Use an outlet that cannot be turned off by a switch. Do not use an extension cord.

NOTE: Before performing any type of installation, cleaning, or removing a light bulb, turn Cooling OFF, and then disconnect the refrigerator from the electrical source. When you have finished, reconnect the refrigerator to the electrical source and turn Cooling ON. See "Using the Controls."

Water Supply Requirements

A cold water supply with water pressure between 30 and 120 psi (207 and 827 kPa) is required to operate the water dispenser and ice maker. If you have questions about your water pressure, call a licensed, qualified plumber.

Reverse Osmosis Water Supply

IMPORTANT: The pressure of the water supply coming out of a reverse osmosis system going to the water inlet valve of the refrigerator needs to be between 30 and 120 psi (207 and 827 kPa).

If a reverse osmosis water filtration system is connected to your cold water supply, the water pressure to the reverse osmosis system needs to be a minimum of 40 to 60 psi (276 to 414 kPa).

If the water pressure to the reverse osmosis system is less than 40 to 60 psi (276 to 414 kPa):

- Check to see whether the sediment filter in the reverse osmosis system is blocked. Replace the filter if necessary.
- Allow the storage tank on the reverse osmosis system to refill after heavy usage. The tank capacity could be too low to keep up with the requirements of the refrigerator.
- If your refrigerator has a water filter, it may further reduce the water pressure when used in conjunction with a reverse osmosis system. Remove the water filter. See "Water Filtration System."

If you have questions about your water pressure, call a licensed, qualified plumber.

Connect the Water Supply

Read all directions before you begin.

IMPORTANT:

- All installations must meet local plumbing code requirements.
- Use copper tubing or Whirlpool supply line, Part Number 8212547RP, and check for leaks.
- Install copper tubing only in areas where the temperatures will remain above freezing.

TOOLS NEEDED:

Gather the required tools and parts before starting installation. Read and follow the instructions provided with any tools listed here.

- Flat-blade screwdriver
- 1/4" Nut driver
- 7/16" and 1/2" Open-end or two adjustable wrenches
- 1/4" Drill bit
- Cordless drill

NOTE: Your refrigerator dealer has a kit available with a 1/4" (6.35 mm) saddle-type shutoff valve, a union, and copper tubing. Before purchasing, make sure a saddle-type valve complies with your local plumbing codes. Do not use a piercing-type or 3/16" (4.76 mm) saddle valve which reduces water flow and clogs more easily.

Connect to Water Line

Style 1

1. Unplug refrigerator or disconnect power.
2. Turn OFF main water supply. Turn ON nearest faucet long enough to clear line of water.
3. Locate a 1/2" to 1 1/4" (1.25 cm to 3.18 cm) vertical cold water pipe near the refrigerator.

IMPORTANT:

- Make sure it is a cold water pipe.
 - Horizontal pipe will work, but drill on the top side of the pipe, not the bottom. This will help keep water away from the drill and normal sediment from collecting in the valve.
4. Determine the length of copper tubing you need. Measure from the connection on the lower left rear of refrigerator to the water pipe. Add 7 ft (2.1 m) to allow for cleaning. Use 1/4" (6.35 mm) O.D. (outside diameter) copper tubing. Be sure both ends of copper tubing are cut square.
 5. Using a cordless drill, drill a 1/4" hole in the cold water pipe you have selected.

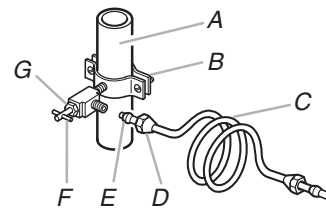

- A. Cold water pipe
- B. Pipe clamp
- C. Copper tubing
- D. Compression nut
- E. Compression sleeve
- F. Shutoff valve
- G. Packing nut

6. Fasten the shutoff valve to the cold water pipe with the pipe clamp. Be sure the outlet end is solidly in the 1/4" (6.35 mm) drilled hole in the water pipe and that the washer is under the pipe clamp. Tighten the packing nut. Tighten the pipe clamp screws slowly and evenly so washer makes a watertight seal. Do not overtighten or you may crush the copper tubing.

- Slip the compression sleeve and compression nut onto the copper tubing as shown. Insert the end of the tubing into the outlet end squarely as far as it will go. Screw compression nut onto outlet end with adjustable wrench. Do not overtighten.
- Place the free end of the tubing in a container or sink, and turn ON the main water supply. Flush the tubing until water is clear. Turn OFF the shutoff valve on the water pipe. Coil the copper tubing.

Style 2

- Unplug refrigerator or disconnect power.
- Remove and discard the black nylon plug from the gray water tube on the rear of the refrigerator.
- Thread the provided nut onto the water valve as shown.

NOTE: Tighten the nut by hand. Then tighten it with a wrench two more turns. Do not overtighten.

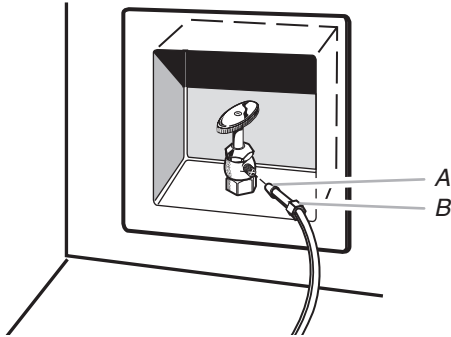

A. Bulb
B. Nut (provided)

- Turn shutoff valve ON.
- Check for leaks. Tighten any nuts or connections (including connections at the valve) that leak.

Connect to Refrigerator

Style 1

- Unplug refrigerator or disconnect power.
- Attach the copper tube to the valve inlet using a compression nut and sleeve as shown. Tighten the compression nut. Do not overtighten.
- Use the tube clamp on the back of the refrigerator to secure the tubing to the refrigerator as shown. This will help avoid damage to the tubing when the refrigerator is pushed back against the wall.
- Turn shutoff valve ON.
- Check for leaks. Tighten any connections (including connections at the valve) or nuts that leak.

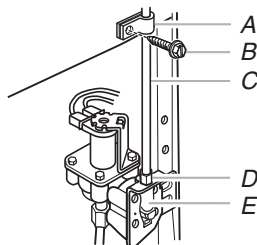

A. Tube clamp
B. Tube clamp screw
C. Copper tubing
D. Compression nut
E. Valve inlet

- On models with ice makers, the ice maker is equipped with a built-in water strainer. If your water conditions require a second water strainer, install it in the 1/4" (6.35 mm) water line at either tube connection. Obtain a water strainer from your nearest appliance dealer.

Style 2

- Unplug refrigerator or disconnect power.
- Remove and discard the black nylon plug from the gray water tube on the rear of the refrigerator.
- If the gray water tube supplied with the refrigerator is not long enough, a 1/4" x 1/4" (6.35 mm x 6.35 mm) coupling is needed in order to connect the water tubing to an existing household water line. Thread the provided nut onto the coupling on the end of the copper tubing.

NOTE: Tighten the nut by hand. Then tighten it with a wrench two more turns. Do not overtighten.

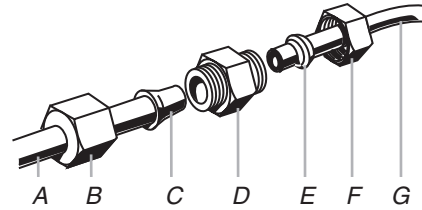

A. Refrigerator water tubing
B. Nut (provided)
C. Bulb
D. Coupling (provided)
E. Ferrule (purchased)
F. Nut (purchased)
G. Household water line

- Turn shutoff valve ON.
- Check for leaks. Tighten any nuts or connections (including connections at the valve) that leak.

Complete the Installation

⚠ WARNING



Electrical Shock Hazard

Plug into a grounded 3 prong outlet.

Do not remove ground prong.

Do not use an adapter.

Do not use an extension cord.

Failure to follow these instructions can result in death, fire, or electrical shock.

- Plug into a grounded 3 prong outlet.

NOTES:

- Allow 24 hours to produce the first batch of ice. Discard the first three batches of ice produced. Allow 3 days to completely fill ice container.
- For models with a water dispenser, flush the water system. See "Water Dispenser."

Handle Installation and Removal

Parts Included: Refrigerator door handles (2),
Freezer drawer handle (1)

Tools Needed: 1/8" Hex key wrench

Install Door Handles

NOTE: Handle mounting setscrews are preinstalled inside the handle.

1. Remove the handles from the packaging inside the refrigerator.
2. Open a refrigerator door. On the opposite door, place the handle on the shoulder screws with the setscrews facing the adjacent door.

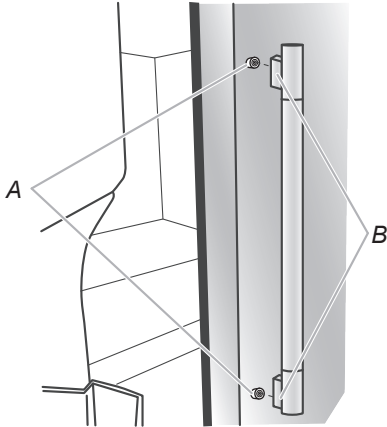

A. Shoulder screws
B. Setscrews inside the handle

3. Firmly push the handle toward the door until the handle base is flush against the door.
4. While holding the handle, insert the short end of the hex key into the upper hole and slightly rotate the hex key until it is engaged in the setscrew.

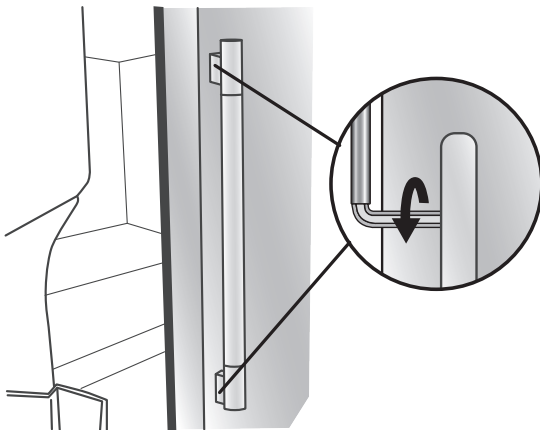

5. Using a clockwise motion tighten the setscrew until the screw feels tight.
6. Repeat steps 4 and 5 to fasten the lower setscrew.
IMPORTANT: When the screws feel tight, tighten them an additional quarter-turn. The handle is not properly installed without this extra tightening.
7. Repeat steps 2 through 6 to install the other handle onto the adjacent refrigerator door.

Install Drawer Handle

1. With the freezer drawer closed, place the handle on the shoulder screws with the setscrews facing down toward the floor.

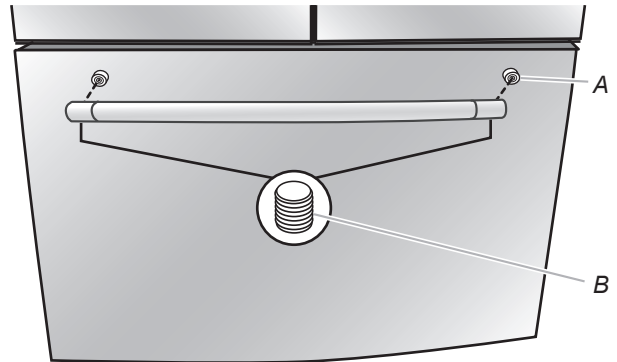

A. Shoulder screw
B. Setscrews inside the handle

2. Firmly push the handle toward the drawer until the handle base is flush against the drawer.
3. Insert the short end of the hex key into the left-hand hole and slightly rotate the hex key until it is engaged in the setscrew.



4. Using a left to right motion tighten the setscrew a quarter-turn at a time. Repeat until the screw feels tight.
5. Repeat steps 3 and 4 to fasten the right-hand setscrew to the shoulder screw.

IMPORTANT: When the screws feel tight, tighten them an additional quarter-turn. The handle is not properly installed without this extra tightening.

6. Save the hex key and all instructions.

Remove the Handles

1. While holding the handle, insert the short end of the hex key into a setscrew hole and slightly rotate the hex key until it is engaged in the setscrew.
2. Using a right to left motion loosen the setscrew a quarter-turn at a time.
3. Repeat steps 1 and 2 for the other setscrew. Slowly pull the handle away from the door or drawer.
4. If necessary, use a Phillips screwdriver to remove the shoulder screws from the door.

Door Closing and Door Alignment

IMPORTANT: To comply with Americans with Disabilities Act (ADA) guidelines, fully retract the rollers into the cabinet to lower the refrigerator.

Door Closing

The base grille covers the leveling screws and roller assemblies located at the bottom of the refrigerator cabinet below the freezer drawer. Before making adjustments, remove the base grille and move the refrigerator to its final location.

1. Remove the base grille. Grasp the grille firmly and pull it toward you.
2. Move the refrigerator to its final location.
NOTE: To allow the refrigerator to roll easier, raise the leveling legs off the floor by turning the leveling screws counterclockwise. The front rollers will be touching the floor.
3. So the doors will close easier, use a $\frac{1}{4}$ " hex driver to turn both leveling screws clockwise. This will raise the front of the refrigerator tilting it slightly downward to the rear. Turn both leveling screws the same amount.

NOTE: Having someone push against the top of the refrigerator takes some weight off the leveling screws. This makes it easier to turn the screws.

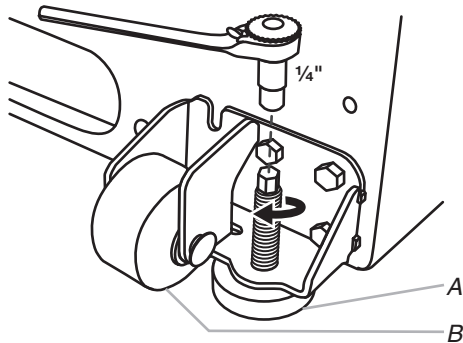

A. Leveling screw
B. Front roller

4. Open both doors again to make sure they close as easily as you like and that they stay closed. If not, tilt the refrigerator slightly more to the rear by turning both leveling screws to the right. It may take several more turns.

NOTE: To keep the refrigerator level, you should turn both leveling screws the same amount.

5. Replace the base grille.
 - Pull open the freezer drawer.
 - Align the three clips on the back of the base grille with the three tabs at the base of the refrigerator.
 - Push the base grille in toward the refrigerator until it is firmly in place.

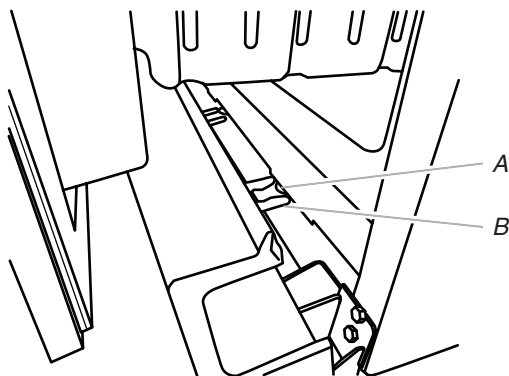

A. Tab
B. Clip

Door Alignment

If the space between the refrigerator doors and freezer drawer looks uneven, you can adjust it using the following instructions:

1. Remove the top hinge cover.
2. Loosen the top hinge screws using a $\frac{5}{16}$ " socket or wrench.
3. Have someone hold the door in place or put a spacer between the doors and drawer.
4. Tighten the top hinge screws once the door is in the desired location.
5. Replace the top hinge cover.

FILTERS AND ACCESSORIES

Water Filtration System

Do not use with water that is microbiologically unsafe or of unknown quality without adequate disinfection before or after the system. Systems certified for cyst reduction may be used on disinfected waters that may contain filterable cysts.

Water Filter Status Light

The water filter status light on the control panel will help you know when to order and replace the water filter.

- GOOD - The water filter icon on the control lights up in BLUE.
- ORDER a replacement filter - The water filter icon on the control lights up in YELLOW.
- REPLACE the water filter - The water filter icon on the control lights up in RED and "Replace Filter" will appear on the display.
- EXPIRED - The water filter icon lights up in RED and "Replace Filter" flashes on the display.

NOTE: If water flow to your water dispenser or ice maker decreases noticeably, change the filter sooner. The disposable water filter should be replaced at least every 6 months, depending on your water quality and usage.

- After changing the water filter, reset the status. Press and hold the WATER FILTER button for 3 seconds. When the system is reset, the water filter icon will return to its BLUE color and the words "Replace Filter" will disappear from the display.

Changing the Water Filter

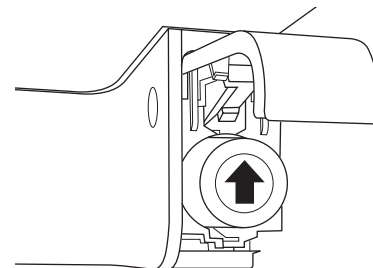

1. Locate the water filter in the top-right corner of the refrigerator compartment.
2. Lift open the filter cover door. The filter will be released and then eject as the door is opened.
3. When the door is completely open, pull the filter straight out.

NOTE: There may be some water in the filter. Some spilling may occur. Use a towel to wipe up any spills.

4. Take the new filter out of its packaging and remove the covers from the O-rings. Be sure the O-rings are still in place after the covers are removed.
5. With the arrow pointing up, align the new filter with the filter housing and slide it into place. The filter cover door will automatically begin to close as the new filter is inserted.
6. Close the filter cover door completely in order to snap the filter into place. You may need to press hard.
7. Flush the water system. See “Water Dispenser”.

Install Air Filter (on some models)

The air filter reduces the buildup of odors. This helps to maintain a cleaner environment inside the refrigerator.

On some models, your refrigerator’s accessory packet includes an air filter, which must be installed prior to use. On some models, the air filter is already installed at the factory.

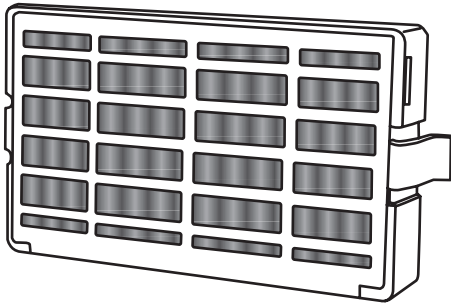

Installing the Air Filter

Install the air filter behind the vented door, located along the rear interior wall of the refrigerator compartment.

1. Remove the air filter from its packaging.
 - NOTE:** An air filter status indicator is included with the air filter. The indicator is not needed for models that display the air filter status on the control panel.
2. Lift open the vented door.
3. Snap the filter into place.

Air Filter Status Indicator

The control panel displays the Air Filter status.

- **GOOD** - The air filter icon on the control lights up in BLUE.
- **ORDER** a replacement - The air filter icon on the control lights up in YELLOW.
- **REPLACE** air filter - The air filter icon on the control lights up in RED and “Replace Filter” will appear.
- **EXPIRED** - The air filter icon lights up in RED and “Replace Filter” flashes on the control display.

After replacing the air filter, press and hold the AIR FILTER button for 3 seconds. The filter icons will turn off. See “Using the Controls.” When the system is reset, the air filter icon will return to its BLUE color and the words “Replace Filter” will disappear from the display.

NOTE: At any filter status, pressing and holding the AIR FILTER button for 3 seconds will reset the air filter status to Good and the air filter icon will turn off.

Replacing the Air Filter

The disposable air filter should be replaced every 6 months, or when the status indicator air filter icon turns on and starts flashing when the refrigerator door is opened.

To order a replacement air filter, contact us. See “Accessories.”

1. Remove the used air filter by squeezing in on the side tabs.
2. Install the new air filter and reset the status indicator using the instructions in the previous section.

Install Produce Preserver (on some models)

The produce preserver absorbs ethylene, to slow the ripening process of many produce items. As a result, certain produce items will stay fresh longer.

Ethylene production and sensitivity varies depending on the type of fruit or vegetable. To preserve freshness, it is best to separate produce with sensitivity to ethylene from fruits that produce moderate to high amounts of ethylene.

	Sensitivity to Ethylene	Ethylene Production
Apples	High	Very High
Asparagus	Med.	Very Low
Berries	Low	Low
Broccoli	High	Very Low
Cantaloupe	Med.	High
Carrots	Low	Very Low
Citrus Fruit	Med.	Very Low
Grapes	Low	Very Low
Lettuce	High	Very Low
Pears	High	Very High
Spinach	High	Very Low

Installing the Produce Preserver

CAUTION: IRRITANT

MAY IRRITATE EYES AND SKIN. DANGEROUS FUMES FORM WHEN MIXED WITH OTHER PRODUCTS.

Do not mix with cleaning products containing ammonia, bleach or acids. Do not get in eyes, on skin or clothing. Do not breathe dust. Keep out of reach of children.

FIRST AID TREATMENT: Contains potassium permanganate. If swallowed, call a Poison Control Center or doctor immediately. Do not induce vomiting. If in eyes, rinse with water for 15 minutes. If on skin, rinse with water.

1. Find the Produce Preserver housing inside the refrigerator.

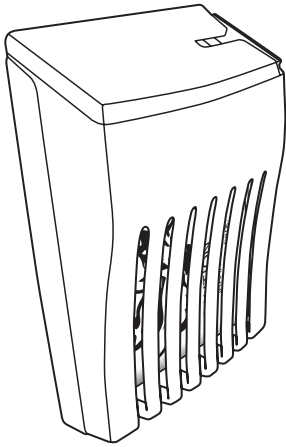

2. Open the housing by pulling up and out on the back.
3. Remove the FreshFlow™ Produce Preserver pouches from the packaging and place them into the housing.
NOTE: For best performance, always use two pouches.
4. Place the Produce Preserver housing onto the tab located on the back wall of the crisper drawer.

Installing the Status Indicator

The produce preserver comes with a status indicator, which should be activated and installed at the same time the pouches are installed.

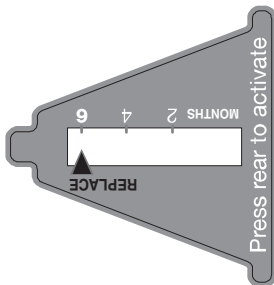

1. Place the indicator face-down on a firm, flat surface.
2. Apply pressure to the bubble on the back of the indicator until the bubble pops, to activate the indicator.
3. Slide open the cap on the top of the produce preserver housing.
4. Place the indicator in the top of the housing, facing outward.
5. Slide the cap closed, and check that the indicator is visible through the rectangular hole in the cap.
NOTE: The cap will not easily close if the indicator's bubble has not been popped.

Replacing the Produce Preserver

The disposable pouches should be replaced every 6 months or when the status indicator changes completely from white to red. To order replacements, contact us. See "Accessories" for information on ordering.

1. Remove the used pouches from the produce preserver housing.
2. Remove the used status indicator.
3. Install the replacement pouches and status indicator using the instructions in the previous sections.

Accessories

The following accessories are available for your refrigerator. To order, contact us and ask for the part numbers.

In the U.S.A., visit our web page www.kitchenaid.com/accessories or call 1-800-901-2042.

In Canada, visit our web page www.whirlpoolparts.ca or call 1-800-807-6777.

affresh®† Stainless Steel Cleaner:

Order Part #W10355016

affresh®† Stainless Steel Wipes:

Order Part #W10355049

affresh®† Kitchen & Appliance Cleaner:

Order Part #W10355010

Water Filter:

Order Part # W10295370A or FILTER1

Air Filter:

Order Part #W10311524 or AIR1

Produce Preserver:

Order Part #W10346771A or FRESH1

Water Filter, Air Filter and Produce Preserver Bundle Pack:

Order Part #W10443987BL

REFRIGERATOR USE

Opening and Closing Doors

There are two refrigerator compartment doors. The doors can be opened and closed either separately or together.

There is a vertically-hinged seal on the left refrigerator door.

- When the left side door is opened, the hinged seal automatically folds inward so that it is out of the way.
- When both doors are closed, the hinged seal automatically forms a seal between the two doors.

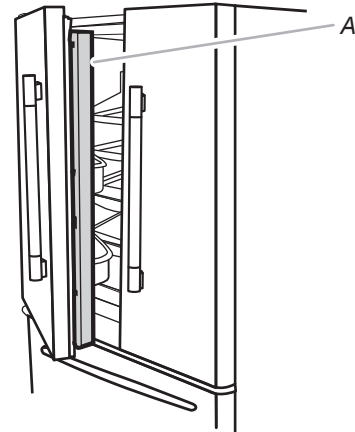

A. Hinged seal

†® AFFRESH is a Trademark of Whirlpool, U.S.A.

Using the Controls

IMPORTANT:

- Wait 24 hours for your refrigerator to cool completely before adding food. If you add food before the refrigerator has cooled completely, your food may spoil.

NOTE: Adjusting the refrigerator and freezer temperature controls to a colder than recommended setting will not cool the compartments any faster.

- The recommended setting should be correct for normal household refrigerator use. The controls are set correctly when milk or juice is as cold as you like and when ice cream is firm.

NOTE: Areas such as a garage or porch may experience warmer or colder temperatures and higher humidity than inside the home. You may need to adjust the temperature away from the recommended set points to accommodate for these conditions.

- If the temperature is too warm or too cold in the refrigerator or freezer, before adjusting the controls, first check the air vents located in the refrigerator and freezer compartments to be sure they are not blocked by food items.

Control Panel

The control panel is located inside the refrigerator compartment. This control operates both the refrigerator and freezer compartments.

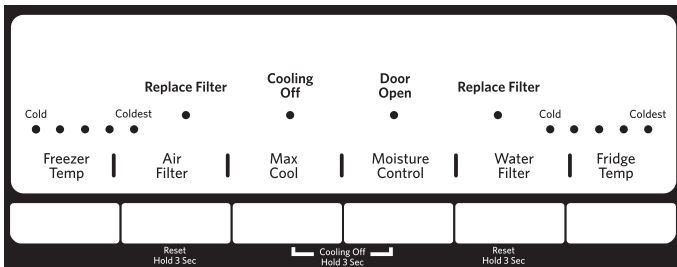

The control panel will display the Home Screen, as shown, when either refrigerator door is opened.

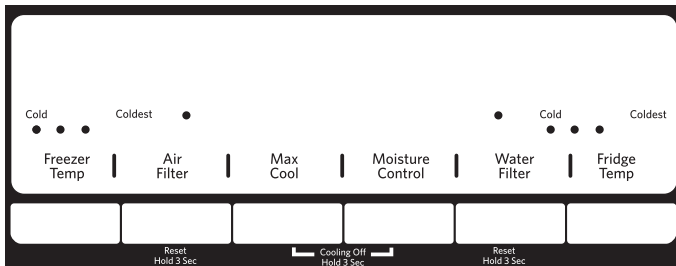

Temperature Control

For your convenience, the temperature control is preset at the factory. When you first install your refrigerator, make sure the control is still set to the recommended setting as shown.

Recommended Setting (3 lit boxes)

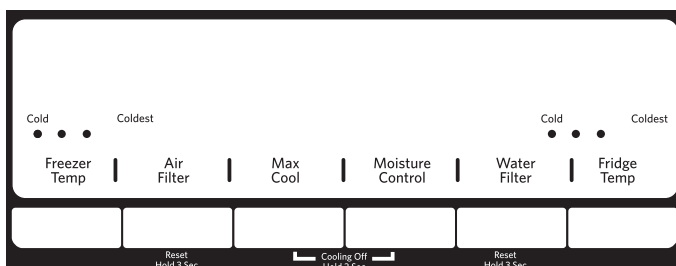

Adjusting the Temperature

If you need to adjust the temperature in either the refrigerator or freezer compartment, use the settings listed in the following chart as a guide.

- Press either the FREEZER TEMP or FRIDGE TEMP button to select the desired temperature setting from (1 box [least cold] to 5 boxes [coldest]).

NOTE: Except when starting the refrigerator, do not adjust the control more than one setting at a time. Wait 24 hours between adjustments for the temperature to stabilize.

CONDITION/REASON:	ADJUSTMENT:
REFRIGERATOR too warm	FRIDGE TEMP one setting (box) more
FREEZER too warm/too little ice	FREEZER TEMP one setting (box) more
REFRIGERATOR too cold	FRIDGE TEMP one setting (box) less
FREEZER too cold	FREEZER TEMP one setting (box) less

Cooling Off/On

Your refrigerator and freezer will not cool and water will not dispense when cooling is turned off.

- To turn cooling off, press and hold both the MAX COOL and MOISTURE CONTROL buttons, at the same time, for 3 seconds. When cooling is off, "Cooling Off" will appear on the display screen.
- To turn cooling back on, press and hold both the MAX COOL and MOISTURE CONTROL buttons, at the same time, for 3 seconds. When cooling is on, "Cooling Off" will disappear and the previously selected settings will appear on the display screen.

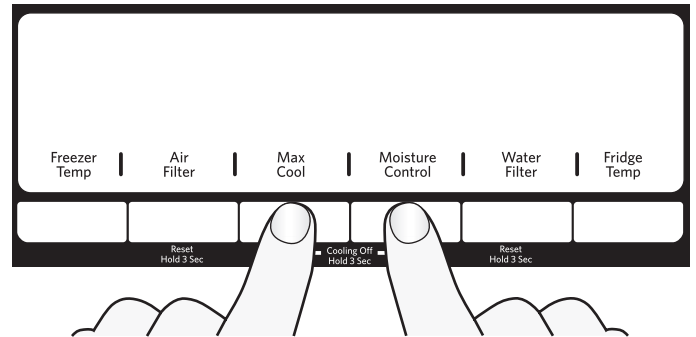

Additional Features

Max Cool

The Max Cool feature assists during times of high refrigerator use, full grocery loads or temporarily warm room temperatures.

- Press MAX COOL to set the freezer and refrigerator to the coldest temperature settings. Press MAX COOL again to return to the selected temperature set point.

NOTES:

- The Max Cool icon will be illuminated while the refrigerator is in Max Cool mode. The displayed compartment temperature settings will not change.
- The Max Cool feature will turn off automatically after 24 hours.



Moisture Control

The moisture control feature turns on a heater to help reduce moisture on the door hinge seal. Use in humid environments or when you notice moisture on the door hinge seal. The refrigerator uses more energy when Moisture Control is on.

- To turn on the Moisture Control feature, press and hold **MOISTURE CONTROL** for 3 seconds.
- To turn off the Moisture Control feature, press and hold **MOISTURE CONTROL** for 3 seconds.

Moisture
Control

Door Open Alarm

- The Door Open icon lights up when a door has been open for 5 minutes and cooling is on. An alert tone will sound three times, and the Door Open icon will flash seven times. This pattern will repeat every 2 minutes until all the doors are closed completely. The feature then resets and will reactivate when a door is left open again for 5 minutes.

NOTES:

- To mute the audible alarm while keeping the doors open, such as while cleaning the inside of the refrigerator, press any button on the control panel. The alarm sound will be temporarily turned off, but the Door Open icon will still be displayed on the dispenser control panel.
- All doors must be completely closed to turn off the Door Open icon.

Door
Open

Sabbath Mode

Sabbath mode is designed for those whose religious observances require turning off the lights.

In Sabbath Mode the temperature set points remain unchanged, but the interior and dispenser lights turn off, all sounds and alarms are disabled and the dispenser screen backlight turns off.

- To turn on Sabbath Mode, press and hold both **FREEZER TEMP** and **FRIDGE TEMP** at the same time for 3 seconds. After 3 seconds, an “engage” tone will sound and the icons on the control panel display will flash and then disappear.

NOTE: You must close the doors to turn off the lights. The lights will remain off while the refrigerator is in Sabbath mode.

- To turn off Sabbath Mode, press and hold both **FREEZER TEMP** and **FRIDGE TEMP** at the same time for 3 seconds. After 3 seconds, a “disengage” tone will sound and the control panel will display the normal screen.

NOTE: After turning off Sabbath Mode, you must first close the doors to turn ON the lights. Then the lights will function normally.

NOTES:

- Sabbath mode does not disable the water dispenser or the ice maker. To turn off the ice maker, see “Ice Maker.”
- If a power failure occurs or you unplug the refrigerator while it is in Sabbath mode, it will take 10 minutes for the cooling system to resume when power is restored.

Water Filter Status Light and Reset

The filter reset control allows you to restart the water filter status tracking feature each time you replace the water filter. See “Water Filtration System.”

- Press and hold **WATER FILTER** for 3 seconds, to reset the water filter status to Good. The Water Filter icon will turn blue.

Air Filter Status Light and Reset

The filter reset control allows you to restart the air filter status tracking feature each time you replace the air filter. See “Install Air Filter.”

- Press and hold **AIR FILTER** for 3 seconds, to reset the air filter status to Good. The Air Filter icon will turn blue.

Water Dispenser

IMPORTANT:

- Allow 3 hours for the refrigerator to cool down and chill water.
- Allow 24 hours to produce the first batch of ice. Discard the first three batches of ice produced.

Flush the Water System

Air in the water dispensing system can cause the water dispenser to drip. After connecting the refrigerator to a water source or replacing the water filter, flush the water system.

Flushing the water dispensing system, forces air from the water line and filter and prepares the water filter for use. Additional flushing may be required in some households.

NOTE: As air is cleared from the system, water may spurt out of the dispenser.

1. Using a sturdy container, depress and hold the water dispenser paddle for 5 seconds.
2. Release the dispenser paddle for 5 seconds. Repeat steps 1 and 2 until water begins to flow.
3. Once water begins to flow, continue depressing and releasing the dispenser pad (5 seconds on, 5 seconds off) until a total of 4 gal. (15 L) has been dispensed.

Dispense Water

1. Hold a container under the dispenser spout while pressing the dispenser pad.
2. Release the dispenser pad to stop dispensing.

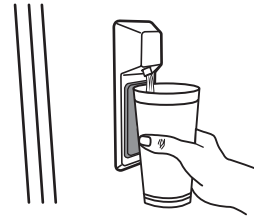

Ice Maker

(on some models)

IMPORTANT: For models with a water filter, after connecting the refrigerator to a water source or replacing the water filter, fill and discard three full containers of ice to prepare the water filter for use.

Turning the Ice Maker On/Off

To turn the ice maker ON, simply lower the wire shutoff arm.

To manually turn the ice maker OFF, lift the wire shutoff arm to the OFF (arm up) position and listen for the click.

NOTE: Your ice maker has an automatic shutoff. As ice is made, the ice cubes will fill the ice storage bin and the ice cubes will raise the wire shutoff arm to the OFF (arm up) position. Do not force the wire shutoff arm up or down.

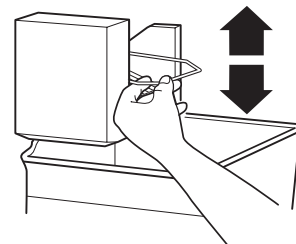

Ice Storage Bin

1. Wash the ice storage bin with mild soap and warm water.
2. Slide the ice storage bin under the ice maker, and push it toward the back as far as it will go.
3. Lower the arm on the ice maker to the “On” position.
NOTE: It usually takes approximately 24 hours for the ice maker to begin producing ice. You may notice the ice has an “off-taste.” If so, discard the first three batches of ice produced. After that the “off-taste” should be gone.

Ice Production Rate

- The ice maker should produce approximately 8 to 12 batches of ice in a 24-hour period. Allow 3 days to completely fill the ice container.
- To increase ice production, lower the freezer and refrigerator temperature. See “Using the Controls.” Wait 24 hours between adjustments.

Remember

- The quality of your ice will be only as good as the quality of the water supplied to your ice maker. Avoid connecting the ice maker to a softened water supply. Water softener chemicals (such as salt) can damage parts of the ice maker and lead to poor quality ice. If a softened water supply cannot be avoided, make sure the water softener is operating properly and is well maintained.
- Do not use anything sharp to break up the ice in the bin. This can cause damage to the ice storage bin and the dispenser mechanism.
- Do not store anything on top of or in the ice maker or ice storage bin.

REFRIGERATOR FEATURES

NOTE: Your model may have some or all of these features.

Important information to know about glass shelves and covers:

Do not clean glass shelves or covers with warm water when they are cold. Shelves and covers may break if exposed to sudden temperature changes or impact, such as bumping. Tempered glass is designed to shatter into many small, pebble-size pieces. This is normal. Glass shelves and covers are heavy. Use both hands when removing them to avoid dropping.

Refrigerator Shelves

The shelves in your refrigerator are adjustable to match your individual storage needs.

Glass Shelves

To remove a shelf:

1. Remove items from the shelf.
2. Slide the shelf straight out to the stop.
3. Depending on your model, lift the back or front of the shelf past the stop. Pull the shelf out the rest of the way.

To replace a shelf:

1. Slide the back of the shelf into the track in the wall of the cabinet.
2. Guide the front of the shelf into the shelf track. Be sure to slide the shelf in all the way.

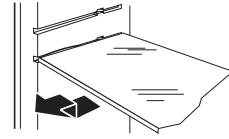

Fold Away Shelf (on some models)

To retract the fold away shelf:

- Retract the fold away section of the shelf by holding the front of the shelf with one hand and lifting up on the center front of the shelf. Then push back and down on the shelf until it slides beneath the back section of the shelf.

To replace the fold away shelf:

- Replace the fold away section of the shelf by holding the front of the shelf with one hand and pulling the center of the shelf until the fold away section is returned to its full shelf position.

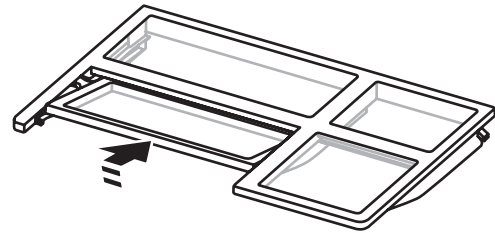

Pantry Drawer

Pantry Drawer

To remove and replace the pantry drawer:

1. Slide pantry drawer out to the stop.
2. Lift front of pantry drawer with one hand while supporting bottom of drawer with other hand. Slide drawer out the rest of the way.
3. Replace the drawer by sliding it back in fully past the drawer stop.

Pantry Drawer Cover

To remove and replace the pantry drawer cover:

1. Remove the pantry drawer.
2. From underneath, push up on the glass cover and pull it out.
3. Replace the pantry drawer cover by lowering it into place.
4. Replace the pantry drawer.

Pantry Drawer Control

The amount of air flowing through the pantry drawer affects the temperature inside the drawer.

The airflow control is located on the left side of the pantry drawer.

To adjust the airflow:

- Colder - Slide the control forward, toward the front of the pantry drawer. The airflow is open.
- Cold - Slide the control all the way toward the rear of the pantry drawer. The airflow is closed, as shown.

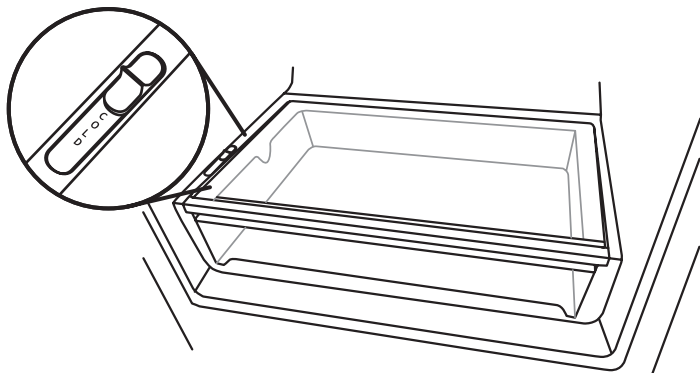

Crisper

Crisper Drawers

To remove and replace the crisper drawer:

1. Slide the crisper drawer straight out to the stop. Lift the front and slide the drawer out the rest of the way.
2. Replace the drawer by sliding the drawer in fully past the stop.

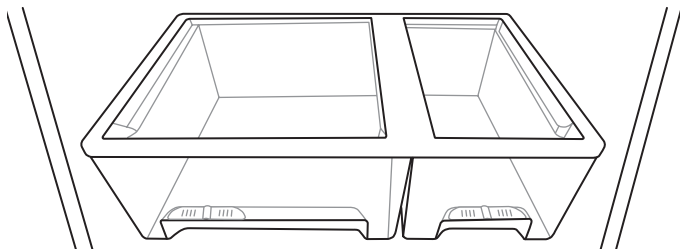

Crisper Cover

To remove and replace the glass crisper cover:

1. Pull the glass straight out.
2. Replace the glass by pushing it straight in.

Crisper Humidity Control (on some models)

You can control the amount of humidity in the moisture-sealed crisper. Adjust the control to any setting between LOW and HIGH. LOW (open) lets moist air out of the crisper for best storage of fruits and vegetables with skins.

- Fruit: Wash, let dry and store in refrigerator in plastic bag or crisper. Do not wash or hull berries until they are ready to use. Sort and keep berries in original container in crisper, or store in a loosely closed paper bag on a refrigerator shelf.
- Vegetables with skins: Place in plastic bag or plastic container and store in crisper.

HIGH (closed) keeps moist air in the crisper for best storage of fresh, leafy vegetables.

- Leafy vegetables: Wash in cold water, drain and trim or tear off bruised and discolored areas. Place in plastic bag or plastic container and store in crisper.

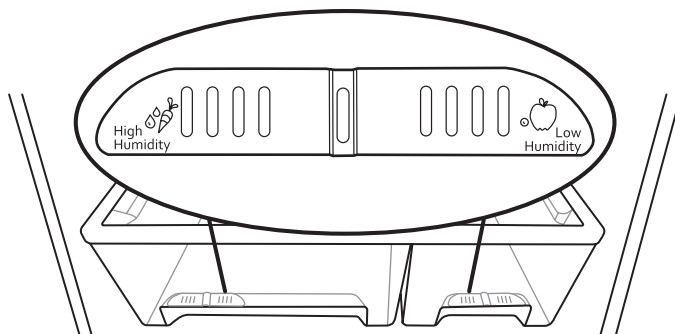

DOOR FEATURES

NOTE: Your model may have some or all of these features.

Condiment Bins

To remove and replace the condiment bins:

1. Tilt the bin by grabbing it and pulling outward.
2. Remove the bin by grabbing it and lifting it upward off the glides.
3. Replace the bin by sliding it back onto the glides and then push it closed.

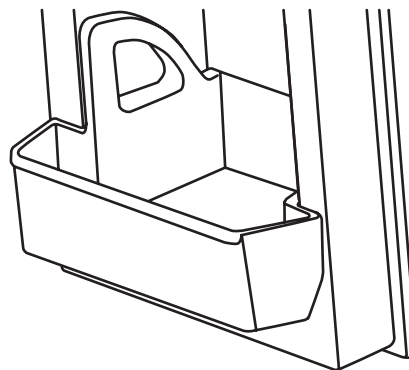

Fresh Bin

(on some models)

To remove and replace the fresh bin:

1. Open the bin by grabbing the top center lip of the bin and tilting the bin outward.
2. Remove the bin by grabbing both sides of the bin and lifting the bin upward off the glides.
3. Replace the bin by sliding it back into its tilted position on the glides and then push it closed.

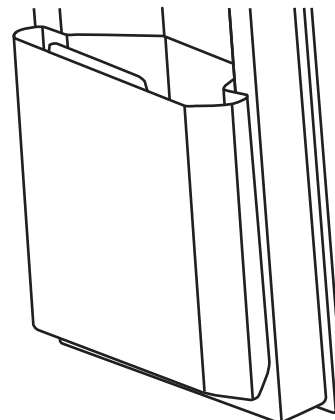

Half-Height Bin

(on some models)

To remove and replace the half-height bin:

1. Tilt the bin by grabbing it and pulling outward.
2. Remove the bin by grabbing it and lifting it upward off the glides.
3. Replace the bin by sliding it back onto the glides and then push it closed.

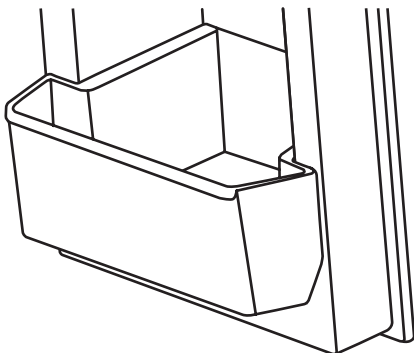

REFRIGERATOR CARE

Cleaning

⚠ WARNING



Explosion Hazard

Use nonflammable cleaner.

Failure to do so can result in death, explosion, or fire.

Both the refrigerator and freezer sections defrost automatically. However, clean both sections about once a month to avoid buildup of odors. Wipe up spills immediately.

IMPORTANT:

- Because air circulates between both sections, any odors formed in one section will transfer to the other. You must thoroughly clean both sections to eliminate odors. To avoid odor transfer and drying out of food, wrap or cover foods tightly.
- For stainless steel models, stainless steel is corrosion-resistant and not corrosion-proof. To help avoid corrosion of your stainless steel, keep your surfaces clean by using the following cleaning instructions.

To Clean Your Refrigerator:

NOTE: Do not use abrasive or harsh cleaners such as window sprays, scouring cleansers, flammable fluids, muriatic acid, cleaning waxes, concentrated detergents, bleaches or cleansers containing petroleum products on exterior surfaces (doors and cabinet), plastic parts, interior and door liners or gaskets. Do not use paper towels, scouring pads, or other harsh cleaning tools.

1. Unplug refrigerator or disconnect power.
2. Hand wash, rinse, and dry removable parts and interior surfaces thoroughly. Use a clean sponge or soft cloth and a mild detergent in warm water.

3. Clean the exterior surfaces.

Painted metal: Wash painted metal exteriors with a clean, soft cloth or sponge and a mild detergent in warm water. Rinse surfaces with clean, warm water and dry immediately to avoid water spots.

Stainless steel: Wash stainless steel surfaces with a clean, soft cloth or sponge and a mild detergent in warm water. Rinse surfaces with clean, warm water and dry immediately to avoid water spots.

NOTE: When cleaning stainless steel, always wipe in the direction of the grain to avoid cross-grain scratching.

4. There is no need for routine condenser cleaning in normal home operating environments. If the environment is particularly greasy or dusty, or there is significant pet traffic in the home, the condenser should be cleaned every 2 to 3 months to ensure maximum efficiency.

If you need to clean the condenser:

- Remove the base grille.
- Use a vacuum cleaner with a soft brush to clean the grille, the open areas behind the grille and the front surface area of the condenser.
- Replace the base grille when finished.

5. Plug in refrigerator or reconnect power.

Changing the Light Bulbs

IMPORTANT:

- Not all appliance bulbs will fit your refrigerator. Be sure to replace the bulb with an appliance bulb of the same size, shape, and wattage.
- To ensure optimum refrigerator performance, replace light bulbs as soon as they burn out.

Refrigerator Compartment Light

The lighting located at the top of the refrigerator compartment never needs to be replaced. If the lights do not illuminate when the door is opened, call for assistance or service. In the U.S.A., call 1-800-253-1301. In Canada, call 1-800-807-6777.

Freezer Compartment Light (on some models)

1. Unplug the refrigerator or disconnect power.
2. Remove the light shield (on some models).
 - Top of the freezer compartment - Slide the light shield toward the back of the compartment to release it from the light assembly.

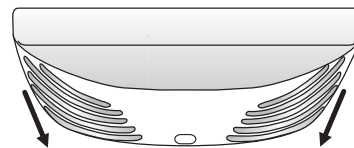

3. Replace the burned-out bulb with an appliance bulb(s) no greater than 25 watts.
4. Replace the light shield.
5. Plug in refrigerator or reconnect power.

Vacation and Moving Care

Vacations

If You Choose to Leave Refrigerator On While You Are Away:

1. Use up any perishables and freeze other items.
2. If your refrigerator has an automatic ice maker and is connected to the household water supply, turn off the water supply to the refrigerator. Property damage can occur if the water supply is not turned off.
3. If you have an automatic ice maker, turn off the ice maker.
NOTE: Depending on your model, raise the wire shutoff arm to OFF (up) position or press the switch to OFF.
4. Empty the ice bin.

If You Choose to Turn Refrigerator Off Before You Leave:

1. Remove all food from the refrigerator.
2. If your refrigerator has an automatic ice maker:
 - Turn off the water supply to the ice maker at least one day ahead of time.
 - When the last load of ice drops, raise the wire shutoff arm to the OFF (up) position or move the switch to the OFF setting.
3. Depending on the model, turn the Refrigerator Control to OFF or turn cooling off. See "Using the Controls" in the User Instructions, User Guide, or Use & Care Guide.
4. Clean, wipe, and dry thoroughly.
5. Tape rubber or wood blocks to the tops of both doors to prop them open far enough for air to get in. This stops odor and mold from building up.

Moving

When you are moving your refrigerator to a new home, follow these steps to prepare it for the move.

1. If your refrigerator has an automatic ice maker:
 - Turn off the water supply to the ice maker at least one day ahead of time.
 - Disconnect the water line from the back of the refrigerator.
 - When the last load of ice drops, raise the wire shutoff arm to the OFF (up) position or move the switch to the OFF setting.
2. Remove all food from the refrigerator and pack all frozen food in dry ice.
3. Empty the ice bin.
4. Depending on the model, turn the Refrigerator Control to OFF or turn cooling off. See "Using the Controls" in the User Instructions, User Guide, or Use & Care Guide.
5. Unplug refrigerator.
6. Clean, wipe, and dry thoroughly.
7. Take out all removable parts, wrap them well, and tape them together so they don't shift and rattle during the move.
8. Depending on the model, raise the front of the refrigerator so it rolls more easily OR screw in the leveling legs so they don't scrape the floor. See "Door Closing and Door Alignment".
9. Tape the doors closed and tape the power cord to the back of the refrigerator.

When you get to your new home, put everything back and refer to the Installation Instructions for preparation instructions. Also, if your refrigerator has an automatic ice maker, remember to reconnect the water supply to the refrigerator.

TROUBLESHOOTING

First try the solutions suggested here or visit our website and reference FAQs (Frequently Asked Questions) to possibly avoid the cost of a service call.
In the U.S.A., www.kitchenaid.com In Canada, www.kitchenaid.ca

Operation

⚠ WARNING



Electrical Shock Hazard

Plug into a grounded 3 prong outlet.

Do not remove ground prong.

Do not use an adapter.

Do not use an extension cord.

Failure to follow these instructions can result in death, fire, or electrical shock.

PROBLEM	POSSIBLE CAUSES	SOLUTIONS
The refrigerator will not operate	Check electrical supply	<p>Plug the power cord into a grounded 3 prong outlet.</p> <p>Do not use an extension cord.</p> <p>Make sure there is power to the outlet. Plug in a lamp to see if the outlet is working.</p> <p>Reset a tripped circuit breaker. Replace any blown fuses. NOTE: If problems continue, contact an electrician.</p>
	Check controls	Make sure the controls are turned on. See "Using the Controls."
	New installation	<p>Allow 24 hours following installation for the refrigerator to cool completely.</p> <p>NOTE: Adjusting the temperature controls to the coldest setting will not cool either compartment quicker.</p>
The motor seems to run too much	High efficiency compressor and fans	This is normal. Larger, more efficient refrigerators run longer.
	The room or outdoor temperature is hot	It is normal for the refrigerator to work longer under these conditions. For optimum performance, place the refrigerator in an indoor, temperature controlled environment. See "Location Requirements."
	A large amount of warm food has been recently added	Warm food will cause the refrigerator to run longer until the air cools to the desired temperature.
	The door(s) are opened too frequently or for too long	Warm air entering the refrigerator causes it to run more. Open the door less often.
	The refrigerator door or freezer drawer is ajar	Make sure the refrigerator is level. See "Door Closing and Door Alignment." Keep food and containers from blocking the door.
	The refrigerator control is set too cold	Adjust the refrigerator control to a less cold setting until the refrigerator temperature is as desired. See "Using the Controls."
	The door or drawer gasket is dirty, worn, or cracked	Clean or change the gasket. Leaks in the door seal will cause the refrigerator to run longer in order to maintain desired temperatures.

PROBLEM	POSSIBLE CAUSES	SOLUTIONS
The lights do not work	A light bulb is loose in the socket or burned out	Tighten or replace the light bulb. See “Changing the Light Bulbs.”
	The dispenser light is set to OFF	On some models, the dispenser light will operate only when a dispenser paddle is pressed. If you want the dispenser light to stay on continuously, see “Water Dispenser.”
	The control is set to Sabbath Mode (on some models)	Turn off Sabbath Mode. See “Using the Controls.”

Noise

PROBLEM	POSSIBLE CAUSES	SOLUTIONS
The refrigerator seems noisy Below are listed some normal sounds with explanations.	The compressor in your new refrigerator regulates temperature more efficiently while using less energy, and operates quietly. Due to the reduction in operating noise you may notice more intermittent noises.	
Sound of the compressor running longer than expected	High efficiency compressor and fans	This is normal. Larger, more efficient refrigerators run longer.
Pulsating/Whirring	Fans/compressor adjusting to optimize performance during normal compressor operation	This is normal
Popping	Contraction/expansion of inside walls, especially during initial cool-down	This is normal
Hissing/Dripping	Flow of refrigerant, or flow of oil in the compressor	This is normal
Vibration	The refrigerator may not be steady	Adjust the leveling screws and lower the leveling foot firmly against the floor. See “Door Closing and Door Alignment.”
Rattling/Banging	Movement of the water lines against the refrigerator cabinet, or of items placed on top of the refrigerator cabinet	Move excess water line away from the refrigerator cabinet or fasten excess tubing to the cabinet. See “Connect the Water Supply,” or remove items from the top of the refrigerator.
Sizzling	Water dripping on the heater during defrost cycle	This is normal
Water running/Gurgling	May be heard when ice melts during the defrost cycle and water runs into the drain pan	This is normal
Buzzing	Heard when the water valve opens to fill the ice maker	This is normal
Creaking/Cracking	May be heard as ice is being ejected from the ice maker mold	This is normal
Ker-plunk	May be heard when the ice falls into the ice storage bin	This is normal

Temperature and Moisture

PROBLEM	POSSIBLE CAUSES	SOLUTIONS
Temperature is too warm	The refrigerator has just been installed	Allow 24 hours following installation for the refrigerator to cool completely.
	Cooling is turned off	Turn on cooling. See “Using the Controls.”
	The controls are not set correctly for the surrounding conditions	Adjust the controls a setting colder. Check the temperature in 24 hours. See “Using the Controls.”
	The door(s) are opened often or not closed completely	Allows warm air to enter refrigerator. Minimize door openings and keep doors fully closed.
	A large load of food was recently added	Allow several hours for refrigerator to return to normal temperature.

PROBLEM	POSSIBLE CAUSES	SOLUTIONS
Temperature is too cold in the refrigerator/crisper	The refrigerator air vent(s) are blocked	If the air vent located in the top, left, rear corner of the refrigerator compartment is blocked by items placed directly in front of it, the refrigerator will get too cold. Move items away from the air vent.
	The controls are not set correctly for the surrounding conditions	Adjust the controls a setting warmer. Check the temperature in 24 hours. See "Using the Controls."
	The ice storage bin is not in the correct position	See "Ice Maker."
Temperature is too cold in the pantry drawers	The control is not set correctly for the items stored in drawer	Adjust the control setting. See "Refrigerator Features."
There is interior moisture buildup NOTE: Some moisture buildup is normal.	The room is humid	A humid environment contributes to moisture buildup.
	The door(s) are opened often or not closed completely	Allows humid air to enter the refrigerator. Minimize door openings and close doors completely.
	The door is blocked open	Move food packages away from door.
	A bin or shelf is in the way	Push bin or shelf back into the correct position.
	Storing liquid in open containers	This adds humidity to the refrigerator interior. Keep all containers tightly covered.
There is frost/ice buildup in the freezer compartment	The doors are opened often or left open	Minimize door openings and keep doors fully closed.
	Poor door seal	Ensure door seals are making full contact with the refrigerator cabinet to allow for an adequate seal.
	Temperature controls are not set correctly	See "Using the Controls" for recommended temperature settings.

Ice and Water

PROBLEM	POSSIBLE CAUSES	SOLUTIONS
The ice maker is not producing ice or is not producing enough ice	The refrigerator is not connected to a water supply or the water supply shutoff valve is not turned on	Connect refrigerator to water supply and turn water shutoff valve fully open.
	There is a kink in the water source line	A kink in the line can reduce water flow. Straighten the water source line.
	The ice maker is not turned on	Make sure the ice maker is on. See "Ice Maker."
	The refrigerator has just been installed	Wait 24 hours after ice maker installation for ice production to begin. Wait 3 days for full ice production.
	The refrigerator door is not closed completely	Close the door firmly. If it does not close completely, see "The doors will not close completely."
	A large amount of ice was recently removed	Allow 24 hours for ice maker to produce more ice.
	An ice cube is jammed in the ice maker ejector arm	Remove ice from the ejector arm with a plastic utensil. NOTE: On some models, press the lever which opens the ice maker door to access the ejector arm.
	A water filter is installed on the refrigerator	Remove the water filter and operate the ice maker. If ice volume improves, then the filter may be clogged or incorrectly installed. Replace filter or reinstall it correctly.
A reverse osmosis water filtration system is connected to your cold water supply	This can decrease water pressure. See "Water Supply Requirements."	

PROBLEM	POSSIBLE CAUSES	SOLUTIONS
The ice cubes are hollow or small NOTE: This is an indication of low water pressure.	The water shutoff valve is not fully open	Turn the water shutoff valve fully open.
	There is a kink in the water source line	A kink in the line can reduce water flow. Straighten the water source line.
	A water filter is installed on the refrigerator	Remove filter and operate ice maker. If ice quality improves, then the filter may be clogged or incorrectly installed. Replace filter or reinstall it correctly.
	A reverse osmosis water filtration system is connected to your cold water supply	This can decrease water pressure. See "Water Supply Requirements."
	Questions remain regarding water pressure	Call a licensed, qualified plumber.
Off-taste, odor or gray color in the ice or water	Recently installed or replaced plumbing connections. New plumbing connections can cause discolored or off-flavored ice and water.	Discard the ice and wash the ice storage bin. Flush the water system with 4 gal. (15 L) of water. Allow 24 hours for the ice maker to make new ice, and discard the first 3 batches of ice produced.
	The ice has been stored too long	Discard ice. Wash ice storage bin. Allow 24 hours for ice maker to make new ice.
	The water has been stored too long	Dispense at least 1 qt (1 L) of water per week to maintain a fresh supply.
	Odor from stored food has transferred to the ice	Use airtight, moistureproof packaging to store food.
	There are minerals (such as sulfur) in the water	A water filter may need to be installed to remove the minerals.
	There is a water filter installed on the refrigerator	Gray or dark discoloration in ice may indicate that the water filtration system needs additional flushing. Flush the water system after installing and before using a new water filter. See "Water Dispenser" for water filter flushing instructions.
	The water filter needs to be replaced	Replace the disposable water filter at least every 6 months or when indicated. See "Water Filtration System."
The water dispenser will not operate properly	The refrigerator is not connected to a water supply or the water supply shutoff valve is not turned on	Connect the refrigerator to the water supply and turn the water shutoff valve fully open.
	There is a kink in the water source line	A kink in the water line can reduce water flow from the water dispenser and result in hollow or irregular shaped ice. Straighten the water source line.
	The refrigerator has just been installed	Flush and fill the water system. See "Water Dispenser."
	The water pressure to the house is not at or above 30 psi (207 kPa)	The water pressure to the house determines the flow from the dispenser. See "Water Supply Requirements."
	A reverse osmosis water filtration system is connected to your cold water supply	A reverse osmosis water filtration system can decrease water pressure. See "Water Supply Requirements."
	A water filter is installed on the refrigerator	Remove filter and operate dispenser. If water flow increases, the water filter may be clogged or incorrectly installed. Replace filter or reinstall it correctly.
	The refrigerator door is not closed completely (on some models)	Close the door firmly. If it does not close completely, see "The doors will not close completely."
	The refrigerator doors were recently removed	Make sure the water dispenser wire/tube assembly has been properly reconnected at the top of the refrigerator door. See "Remove and Replace Refrigerator Doors and Drawer Front."

PROBLEM	POSSIBLE CAUSES	SOLUTIONS
Water is leaking or dripping from the dispenser system NOTE: A few drops of water after dispensing is normal.	The glass was not held under the dispenser long enough	Hold the glass under the dispenser 2 to 3 seconds after releasing the dispenser lever.
Water continues to drip from the dispenser beyond the first few drops.	The refrigerator has just been installed	Flushing the water system removes the air from the lines which causes the water dispenser to drip. Flush the water system. See “Water Dispenser.”
	The water filter was recently changed	Flushing the water system removes the air from the lines which causes the water dispenser to drip. Flush the water system. See “Water Dispenser.”
Water is leaking from the back of the refrigerator	The water line connections were not fully tightened	See “Connect the Water Supply.”
	Recently removed the doors and did not fully tighten water line connection	See “Remove and Replace Refrigerator Doors and Drawer Front.”
Water from the dispenser is warm NOTE: Water from the dispenser is only chilled to 50°F (10°C).	The refrigerator has just been installed	Allow 24 hours after installation for the water supply to cool completely.
	A large amount of water was recently dispensed	Allow 3 hours for the water supply to cool completely.
	Water has not been recently dispensed	The first glass of water may not be cool. Discard the first glass of water dispensed.
	The refrigerator is not connected to a cold water pipe	Make sure the refrigerator is connected to a cold water pipe. See “Water Supply Requirements.”

Doors



PROBLEM	POSSIBLE CAUSES	SOLUTIONS
The door(s) or drawer will not close completely	The door or drawer is blocked open	Move food packages away from door(s). Remove ice or other items which have fallen onto the floor of the freezer compartment.
	A bin or shelf is in the way	Push bin or shelf back into the correct position.
	Recently installed	Remove all packaging materials.
The doors are difficult to open	The door gaskets are dirty or sticky	Clean gaskets and contact surfaces with mild soap and warm water. Rinse and dry with soft cloth.
The doors appear to be uneven	The doors need to be aligned or the refrigerator needs to be leveled	See “Door Closing and Door Alignment.”
The doors do not open or close as expected	The refrigerator tilt needs to be adjusted	Adjust the refrigerator tilt. See “Door Closing and Door Alignment.”

WATER FILTER CERTIFICATIONS

State of California
Department of Public Health
Water Treatment Device
Certificate Number
11 - 2069
Date Issued: March 15, 2011

<u>Trademark/Model Designation</u> P5WB12NL	<u>Replacement Elements</u> P4RFWB12
Manufacturer: Whirlpool Corp.	
The water treatment device(s) listed on this certificate have met the testing requirements pursuant to Section 116830 of the Health and Safety Code for the following health related contaminants:	
<u>Microbiological Contaminants and Turbidity</u> Cysts	<u>Inorganic/Radiological Contaminants</u> Asbestos Lead
<u>Organic Contaminants</u> Atrazine Lindane Toxaphene 2,4-D	
Rated Service Capacity: 120 gallons	Rated Service Flow: 0.5 gpm

Conditions of Certification:
Do not use where water is microbiologically unsafe or with water of unknown quality, except that systems certified for cyst reduction may be used on disinfected waters that may contain filterable cysts.

PERFORMANCE DATA SHEET

Water Filtration System Model P8WB2L/P8RFWB2L Capacity 200 Gallons (757 Liters)



System tested and certified by NSF International against NSF/ANSI Standard 42, Standard 53, and Standard 401 for the reduction of contaminants specified on the Performance Data Sheet.

This system has been tested according to NSF/ANSI Standards 42, 53 and 401 for the reduction of the substances listed below. The concentration of the indicated substances in water entering the system was reduced to a concentration less than or equal to the permissible limit for water leaving the system, as specified in NSF/ANSI Standards 42, 53 and 401.

Substance Reduction	Influent Challenge Concentration	Maximum Permissible Product Water Concentration	Average% Reduction
Aesthetic Effects			
Chlorine Taste/Odor	2.0 mg/L ± 10%	50% reduction	97.0%
Particulate Class I*	At least 10,000 particles/mL	85% reduction	>99.9%
Contaminant Reduction	Influent Challenge Concentration	Maximum Permissible Product Water Concentration	Average% Reduction
Lead: @ pH 6.5 / @ pH 8.5	0.15 mg/L ± 10%	0.010 mg/L	>99.3% / 98.6%
Benzene	0.015 mg/L ± 10%	0.005 mg/L	93.8%
p-Dichlorobenzene	0.225 mg/L ± 10%	0.075 mg/L	99.8%
Carbofuran	0.08 mg/L ± 10%	0.040 mg/L	81.9%
Toxaphene	0.015 ± 10%	0.003 mg/L	>95%
Atrazine	0.009 mg/L ± 10%	0.003 mg/L	87.0%
Asbestos	10 ⁷ to 10 ⁸ fibers/L ^{††}	99%	>99%
Live Cysts [†]	50,000/L min.	99.95%	>99.99%
Turbidity	11 NTU ± 10%	0.5 NTU	96.9%
Lindane	0.002 ± 10%	0.0002 mg/L	>99.2%
Tetrachloroethylene	0.015 mg/L ± 10%	0.005 mg/L	96.6%
o-Dichlorobenzene	1.8 mg/L ± 10%	0.60 mg/L	92.3%
Ethylbenzene	2.1 mg/L ± 10%	0.70 mg/L	86.9%
1,2,4-Trichlorobenzene	0.210 mg/L ± 10%	0.07 mg/L	>99.8%
2,4 - D	0.210 mg/L ± 10%	0.07 mg/L	88.5%
Styrene	2.0 mg/L ± 10%	0.1 mg/L	99.6%
Toluene	3.0 mg/L ± 10%	1.0 mg/L	93.5%
Endrin	0.006 mg/L ± 10%	0.002 mg/L	81.7%
Atenolol	200 ± 20%	30 ng/L	95.7%
Trimethoprim	140 ± 20%	20 ng/L	96.1%
Linuron	140 ± 20%	20 ng/L	96.3%
Estrone	140 ± 20%	20 ng/L	95.3%
Nonylphenol	1400 ± 20%	200 ng/L	95.5%

Test Parameters: pH = 7.5 ± 0.5 unless otherwise noted. Flow = 0.75 gpm (2.84 Lpm). Pressure = 60 psig (413.7 kPa). Temp. = 68°F to 71.6°F (20°C to 22°C). Rated service capacity = 200 gallons (757 liters).

The compounds certified under NSF 401 have been deemed as “emerging compounds/incidental contaminants.” Emerging compounds/incidental contaminants are those compounds that have been detected in drinking water supplies at trace levels. While occurring at only trace levels, these compounds can affect the public acceptance/perception of drinking water quality.

- It is important that operational, maintenance, and filter replacement requirements be carried out for the product to perform as advertised. Property damage can occur if all instructions are not followed.
- The disposable cartridge must be changed at least every 6 months.
- Use replacement filter P8RFWB2L, part #EDR1RXD1/EDR1RXD1B. 2015 suggested retail price of \$49.99 U.S.A./\$49.99 Canada. Prices are subject to change without notice.
- The filter monitor system measures the amount of water that passes through the filter and alerts you when it is time to replace the filter. Refer to the “Using the Controls” or “Water Filtration System” section (in the User Instructions or User Guide) to learn how to check the water filter status.
- After changing the water filter, flush the water system. See “Water and Ice Dispensers” or “Water Dispenser” in the User Instructions or User Guide.
- These contaminants are not necessarily in your water supply. While testing was performed under standard laboratory conditions, actual performance may vary.
- The product is for cold water use only.
- The water system must be installed in compliance with state and local laws and regulations.
- Do not use with water that is microbiologically unsafe or of unknown quality without adequate disinfection before or after the system. Systems certified for cyst reduction may be used on disinfected waters that may contain filterable cysts. EPA Est. No. 082047-TWN-001
- Refer to the “Warranty” section (in the User Instructions or User Guide) for the Manufacturer’s limited warranty, name and telephone number.

Application Guidelines/Water Supply Parameters

Water Supply	Potable City or Well
Water Pressure	30 - 120 psi (207 - 827 kPa)
Water Temperature	33° - 100°F (0.6° - 37.8°C)
Service Flow Rate	0.75 gpm (2.84 L/min) @ 60 psi

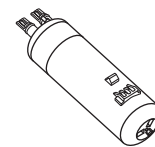

*Class I particle size: >0.5 to <1 um

†Based on the use of Cryptosporidium parvum oocysts

††Fibers greater than 10 um in length

KITCHENAID® REFRIGERATION LIMITED WARRANTY

ATTACH YOUR RECEIPT HERE. PROOF OF PURCHASE IS REQUIRED TO OBTAIN WARRANTY SERVICE.

Please have the following information available when you call the Customer eXperience Center:

- Name, address and telephone number
- Model number and serial number
- A clear, detailed description of the problem
- Proof of purchase including dealer or retailer name and address

IF YOU NEED SERVICE:

1. Before contacting us to arrange service, please determine whether your product requires repair. Some questions can be addressed without service. Please take a few minutes to review the Troubleshooting or Problem Solver section of the Use and Care Guide, scan the QR code on the right to access additional resources, or visit <http://kitchenaid.custhelp.com>.
2. All warranty service is provided exclusively by our authorized KitchenAid Service Providers. In the U.S. and Canada, direct all requests for warranty service to:

KitchenAid Customer eXperience Center

In the U.S.A., call 1-800-422-1230. In Canada, call 1-800-807-6777.

If outside the 50 United States or Canada, contact your authorized KitchenAid dealer to determine whether another warranty applies.



<http://kitchenaid.custhelp.com>

TEN YEAR LIMITED WARRANTY

WHAT IS COVERED

LIMITED WARRANTY

For one year from the date of purchase, when this major appliance is installed, operated and maintained according to instructions attached to or furnished with the product, KitchenAid brand of Whirlpool Corporation or Whirlpool Canada LP (hereafter "KitchenAid") will pay for Factory Specified Replacement Parts and repair labor to correct defects in materials or workmanship that existed when this major appliance was purchased, or at its sole discretion replace the product. In the event of product replacement, your appliance will be warranted for the remaining term of the original unit's warranty period.

SECOND THROUGH FIFTH YEAR LIMITED WARRANTY ON CAVITY LINER AND SEALED REFRIGERATION SYSTEM

In the second through fifth years from the date of purchase, when this major appliance is installed, operated and maintained according to the instructions attached to or furnished with the product, KitchenAid brand will pay for factory specified replacement parts and repair labor for the following components to correct non-cosmetic defects in materials and workmanship in this part that prevent function of the refrigerator and that existed when this major appliance was purchased:

- Refrigerator/freezer cavity liner if the part cracks due to defective materials or workmanship.
- Sealed Refrigeration system (includes compressor, evaporator, condenser, dryer and connecting tubing).

SIXTH THROUGH TENTH YEAR LIMITED WARRANTY (SEALED REFRIGERATION SYSTEM ONLY - LABOR NOT INCLUDED)

In the sixth through tenth year from the date of purchase, when this major appliance is installed, operated and maintained according to instructions attached to or furnished with the product, KitchenAid brand will pay for factory specified replacement parts for the following components to correct defects in materials or workmanship in the sealed refrigeration system (includes compressor, evaporator, condenser, dryer and connecting tubing) that existed when this major appliance was purchased.

YOUR SOLE AND EXCLUSIVE REMEDY UNDER THIS LIMITED WARRANTY SHALL BE PRODUCT REPAIR AS PROVIDED HEREIN. Service must be provided by a KitchenAid designated service company. This limited warranty is valid only in the United States or Canada and applies only when the major appliance is used in the country in which it was purchased. This limited warranty is effective from the date of original consumer purchase. Proof of original purchase date is required to obtain service under this limited warranty.

WHAT IS NOT COVERED

1. Commercial, non-residential or multiple-family use, or use inconsistent with published user, operator or installation instructions.
2. In-home Instruction on how to use your product
3. Service to correct improper product maintenance or installation, installation not in accordance with electrical or plumbing codes or correction of household electrical or plumbing (i.e. house wiring, fuses or water inlet hoses).
4. Consumable parts (i.e. light bulbs, batteries, air or water filters, preservation solutions, etc.).
5. Defects or damage caused by the use of non-genuine KitchenAid parts or accessories.
6. Damage from accident, misuse, abuse, fire, floods, acts of God or use with products not approved by KitchenAid.
7. Repairs to parts or systems to correct product damage or defects caused by unauthorized service, alteration or modification of the appliance.
8. Cosmetic damage including scratches, dents, chips, and other damage to appliance finishes unless such damage results from defects in materials and workmanship and is reported to KitchenAid within 30 days.
9. Discoloration, rust or oxidation of surfaces resulting from caustic or corrosive environments including but not limited to high salt concentrations, high moisture or humidity or exposure to chemicals.
10. Food or medicine loss due to product failure.
11. Pick-up or delivery. This product is intended for in-home repair.
12. Travel or transportation expenses for service in remote locations where an authorized KitchenAid servicer is not available.
13. Removal or reinstallation of inaccessible appliances or built-in fixtures (i.e. trim, decorative panels, flooring, cabinetry, islands, countertops, drywall, etc.) that interfere with servicing, removal or replacement of the product.
14. Service or parts for appliances with original model/serial numbers removed, altered or not easily determined.

The cost of repair or replacement under these excluded circumstances shall be borne by the customer.

DISCLAIMER OF IMPLIED WARRANTIES

IMPLIED WARRANTIES, INCLUDING ANY IMPLIED WARRANTY OF MERCHANTABILITY OR IMPLIED WARRANTY OF FITNESS FOR A PARTICULAR PURPOSE, ARE LIMITED TO ONE YEAR OR THE SHORTEST PERIOD ALLOWED BY LAW. Some states and provinces do not allow limitations on the duration of implied warranties of merchantability or fitness, so this limitation may not apply to you. This warranty gives you specific legal rights, and you also may have other rights that vary from state to state or province to province.

DISCLAIMER OF REPRESENTATIONS OUTSIDE OF WARRANTY

KitchenAid makes no representations about the quality, durability, or need for service or repair of this major appliance other than the representations contained in this warranty. If you want a longer or more comprehensive warranty than the limited warranty that comes with this major appliance, you should ask KitchenAid or your retailer about buying an extended warranty.

LIMITATION OF REMEDIES; EXCLUSION OF INCIDENTAL AND CONSEQUENTIAL DAMAGES

YOUR SOLE AND EXCLUSIVE REMEDY UNDER THIS LIMITED WARRANTY SHALL BE PRODUCT REPAIR AS PROVIDED HEREIN. KITCHENAID SHALL NOT BE LIABLE FOR INCIDENTAL OR CONSEQUENTIAL DAMAGES. Some states and provinces do not allow the exclusion or limitation of incidental or consequential damages, so these limitations and exclusions may not apply to you. This warranty gives you specific legal rights, and you also may have other rights that vary from state to state or province to province.