

MOTION-ACTIVATED WALL LANTERN

MODEL #VEL-03091103CA-PIR-BZ

Portfolio® is a registered trademark of LF, LLC. All rights reserved.

Français p. 9

Español p. 17

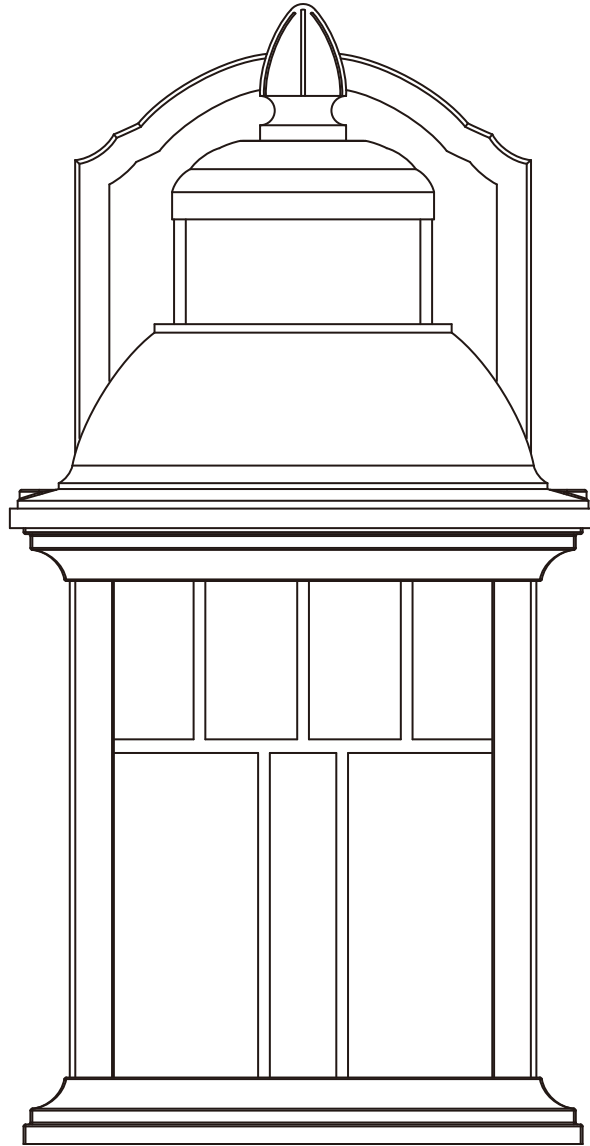

ATTACH YOUR RECEIPT HERE

Serial Number _____ Purchase Date _____



Questions, problems, missing parts? Before returning to your retailer, call our customer service department at 1-800-643-0067, 8 a.m. – 6 p.m., EST, Monday – Thursday, 8 a.m. – 5 p.m., EST, Friday

PACKAGE CONTENTS

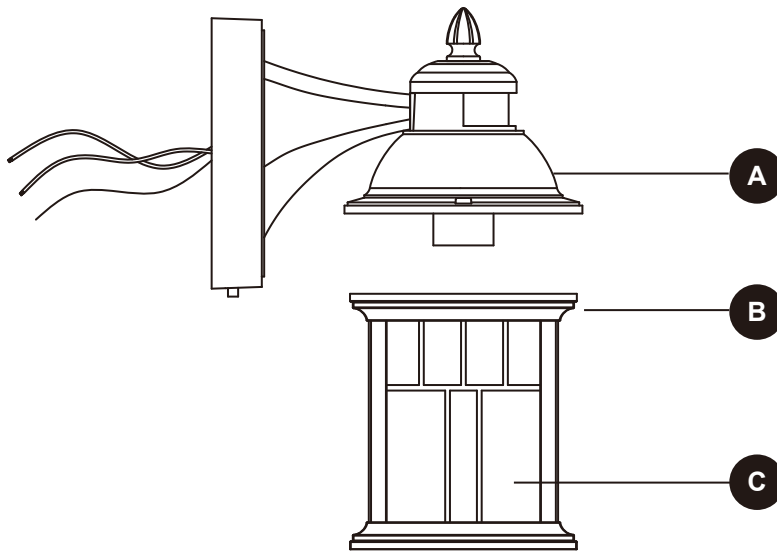

PART	DESCRIPTION	QUANTITY
A	Fixture body	1
B	Cage	1
C	Glass (preassembled to Cage (B))	3

HARDWARE CONTENTS (shown actual size)

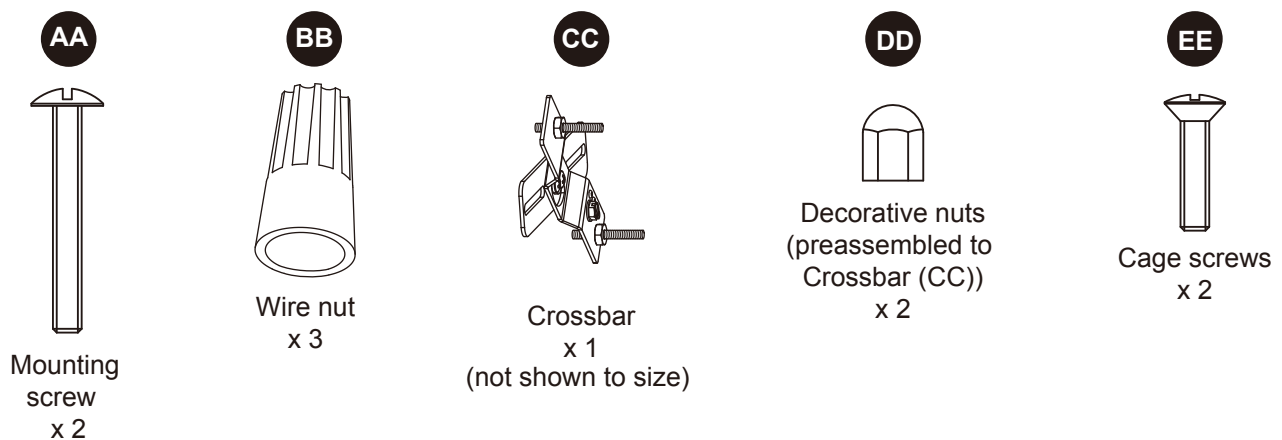

⚠ SAFETY INFORMATION

Please read and understand this entire manual before attempting to assemble, operate or install the product.

CAUTION

- Turn off the main power at circuit breaker before installing fixture.
- There is no serviceable part inside the motion sensor. Do not try to repair or disassemble the unit. Doing so could damage the unit and cause possible electrical shock. Consult a qualified electrician if needed.
- Save these instructions.

WARNING

- All electrical connections must be in accordance with local and National Electrical Code standards. If you are unfamiliar with proper electrical wiring connections, obtain the services of a qualified electrician.
- This light fixture is designed to fit standard junction boxes as defined by the National Electrical Code. Please contact a qualified electrician if you have any questions regarding the installation.

PREPARATION

Before beginning to assemble or install lighting fixture, make sure all parts are present. Compare parts with package contents list and hardware contents list. If any part is missing or damaged, do not attempt to assemble, install or operate the fixture.

Estimated Assembly Time: 30 – 60 minutes (Installation time will vary depending on skill level and existing wiring conditions. Estimated installation time assumes standard wall junction box and supply wiring are already installed).

Tools Required for Assembly (not included): Phillips screwdriver, slotted screwdriver, wrench or pliers, silicone caulking adhesive and caulking gun.

Helpful tools (not included): Wire cutters and/or wire strippers, step ladder.

ASSEMBLY INSTRUCTIONS

1. Turn OFF power to work area at main circuit breaker or fuse box. CAUTION: Do not rely on the wall switch alone to turn off power.

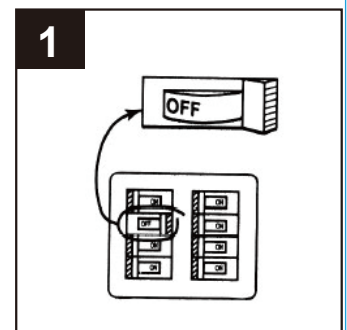

2. Install a bulb (not included) to the socket of the fixture body (A). Do not exceed a 100-watt incandescent light bulb. Attach the cage (B) to the fixture body (A) using the cage screws (EE).

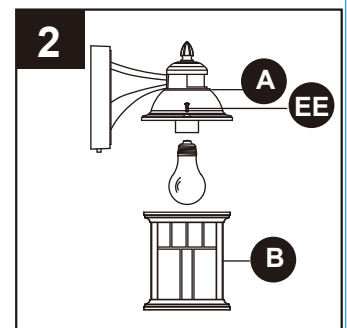

Hardware Used

EE Cage Screw  x 2

ASSEMBLY INSTRUCTIONS

3. Remove the crossbar (CC) and two decorative nuts (DD) from accessory bag. Save decorative nuts (DD) for later. Attach the crossbar (CC) to the junction box (not included) with the mounting screws (AA).

Hardware Used

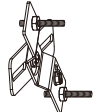
AA	Mounting Screw		x 2
CC	Crossbar		x 1

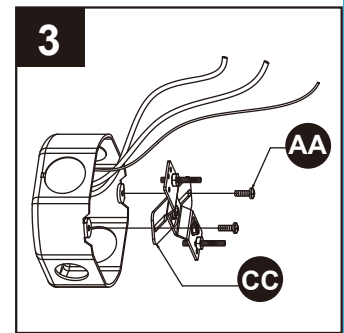

4. Attach the black supply wire to the black fixture wire and the white supply wire to the white fixture wire using wire nuts (BB). Connect the fixture ground wire and the supply ground wire together using a wire nut (BB). Wrap all wire connections with electrical tape (not included) for a more secure connection. Note: If you have electrical questions, consult your local electrical code for approved grounding methods.

Hardware Used

BB	Wire Nut		x 3
-----------	----------	---	-----

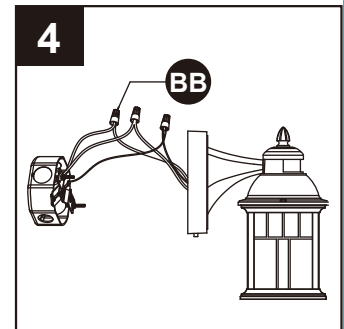

5. Make sure wire connections are secure. Carefully position wires and wire nuts (BB) into the junction box. Place the wall plate of fixture body (A) over the junction box and onto the mounting screws. Adjust the mounting screws until they protrude out from the wall plate 1/4 in. Remove the wall plate and secure the position of the mounting screws by tightening the hex nuts preassembled to crossbar (CC). Place the wall plate back onto the fixture mounting screws, and secure it into place using the decorative nuts (DD).

Hardware Used

DD	Decorative Nut		x 2
-----------	----------------	---	-----

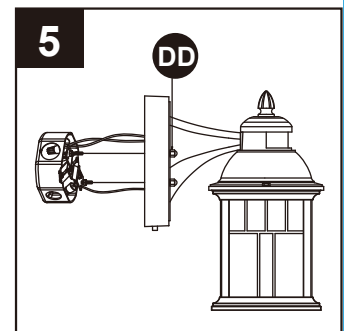

⚠ CAUTION: The lamp fixture is designed to be mounted so that the motion detector controls face toward the ground. If the lamp fixture is mounted in any other position, it may be possible for water to enter the unit and cause damage to the unit and cause possible electric shock. Make sure the controls are facing toward the ground!

⚠ IMPORTANT: After mounting the fixture, it will be necessary to apply silicone sealant caulking compound to the perimeter of the fixture where the back of the cover plate meets the mounting surface. Silicone caulking prevents water from entering the junction box.

Your installation is now complete. Turn on power at the circuit breaker and flip the wall switch to the ON position. The wall switch must remain in the ON position for the motion detector to operate properly.

OPERATING INSTRUCTIONS

GETTING STARTED:

After installing the fixture, slide the "TIMER" switch to "TEST". Restore power at the circuit breaker and turn on your wall switch (if applicable). The light will turn on and remain on for approximately 45 seconds. Then the light will flash 3 times and turn off.

In the beginning, it is necessary to first switch to TEST mode, which will allow you to easily set the motion sensor sensitivity. In TEST mode, the motion sensor will turn on the light when it senses movement. Four to five seconds after movement has stopped, the light will turn off.

SETTING SENSITIVITY IN TEST MODE:

(NOTE: Sensitivity directly correlates to the sensor's detection range). In TEST mode, slide the "SENSITIVITY" switch to a desired level: "L" for low, "M" for medium, or "H" for high. From a distance, walk through the coverage area. When the light turns on, note your distance from the fixture. Try different approaches toward the fixture from various angles. Try pathways where you expect high traffic, such as walkways and driveways.

If necessary, select a different "SENSITIVITY" switch position to increase or decrease sensitivity/range. Repeat the steps above. Continue to adjust the sensitivity until optimum results are attained.

SELECTING FUNCTION:

After setting the sensitivity, select the function by sliding to "TIMER" switch to one of the following positions:

"TIMER" Switch Position	Function	Description
4	Motion Sensor	At dusk, the motion sensor will activate (Motion Sensing Mode). Any movement within the coverage area, will cause the light to turn on. After movement has stopped, the light will remain on for the preset time limit (4 or 10 minutes). At the time limit, the light will turn off. The motion sensor will remain active throughout the night. At dawn, the motion sensor will deactivate.
10		

NOTE: To make sure the above functions operate properly, always keep the wall switch in the "ON" position (including the daytime).

To meet ENERGY STAR requirements the timer switch must be set to 4 or 10 to prevent operation during full daylight.

SELECTING A LOCATION:

- When selecting a location, be aware of the motion sensor's maximum range of 30 ft. and 220° detection angle (Fig. 1). In addition, be aware of its 15° detection down-angle (from horizontal) (Fig. 2). Mounting the fixture too high or in front of a sloped surface, such as an uphill walkway or driveway, may affect the motion sensor's effectiveness.

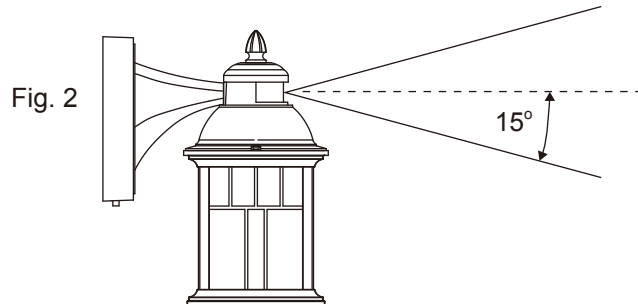
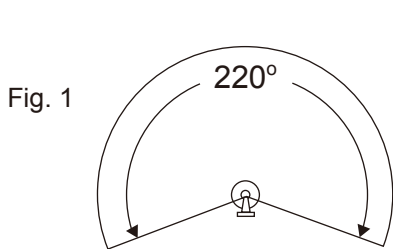

OPERATING INSTRUCTIONS

- Select locations away from heat sources, such as heating vents, air conditioners, and heated swimming pools.
- When selecting a location, be aware that the motion sensor is more sensitive to movement across its coverage area and less sensitive to movement toward or away from the motion sensor (Fig. 3).

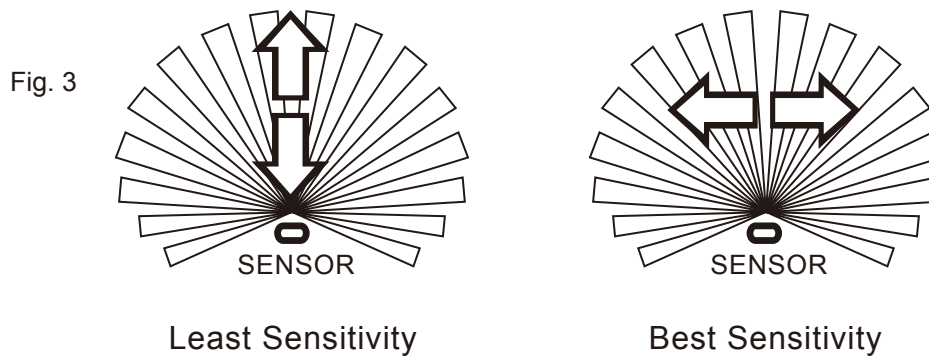

- Select locations away from nighttime light sources, such as street lamps or other light fixtures. They may shine light onto the fixture's photocell sensor (located at the bottom of the back plate, between the two switches). This light might cause the circuit to "think" that it is daytime and not allow the fixture's functions to operate.
- Be aware that shade from a porch or an eave may not allow enough daylight to shine onto the photocell sensor and may cause the circuit to "think" that it is nighttime, and subsequently cause the light to come on during the daytime.
- Be aware that motorized equipment, such as power tools, on the same electrical circuit may cause oscillations on the electrical line that might cause the fixture to malfunction.

ADDITIONAL NOTE:

- This fixture uses one 100-watt max. A19-shape incandescent bulb (not included).
- Select a lamp with rated life of 3,000 hours or more.
- Minimum starting temperature for lamp is -0.4°F .

CARE AND MAINTENANCE

Clean the glass and coated metal surfaces with a non-abrasive cleaner. Do not use any cleaners with chemicals, solvents or harsh abrasives. The motion detecting lens is coated with a specially painted finish and requires special care when cleaning. Use only a soft dry cloth to dust or wipe the lens area. Another area that will need special attention is the photocell window. The photocell detects light through this small window. Keep this area clean to prevent dirt from collecting.

Excessive accumulation of dirt or dust on the photocell window may cause the lantern to come on during the day. The light fixture is designed to safely operate with a single 100 watt medium-base incandescent bulb (not included). DO NOT over lamp this fixture. Some models require the removal of a cover to access the bulb. To remove the cover, remove the decorative nuts that secure the cover in place. Replace the decorative nuts after installing the bulb.

TROUBLESHOOTING

PROBLEM	POSSIBLE CAUSE	CORRECTIVE ACTION
In motion sensing mode, the light does not turn on when there is motion.	<ol style="list-style-type: none"> 1. Wall switch or circuit breaker is off. 2. Light bulb may be dead. 3. Light bulb is loose. 4. Incorrect or loose wire connections. 5. Too much sunlight is shining onto photocell sensor in the early evening. 6. Too much light is shining onto photocell sensor due to another light source, such as a street lamp or other light fixture. 7. Moving persons or vehicles are below the view of the motion sensor, because motion sensor is mounted too high. 	<ol style="list-style-type: none"> 1. Turn on switch or circuit breaker. 2. Test the light bulb in a known working light fixture. Replace light bulb. 3. Tighten light bulb in socket. 4. Check wire connections. 5. Relocate fixture away from a western facing wall. 6. Eliminate or turn off other light source. OR Block other light source from shining onto photocell sensor. OR Relocate fixture. 7. Relocate fixture to a lower position or to a different location.
In motion sensing mode, the light stays on continuously.	False triggering caused by a heat source, such as a heater or dryer vent or heated swimming pool.	Eliminate heat source. OR Relocate fixture.
The light comes on for no apparent reason.	<ol style="list-style-type: none"> 1. Street or sidewalk traffic is triggering the motion sensor. 2. False triggering cause by a heat source, such as a heater or dryer vent or heated swimming pool. 	<ol style="list-style-type: none"> 1. Lower the sensitivity. 2. Eliminate heat source. OR Relocate fixture.
The light comes on during the daytime or too early in the evening.	The fixture may be installed in a shaded area, such as under a porch or eave, preventing daylight from shining onto the photocell sensor.	Relocate fixture.
In motion sensing mode, the light always on during the daytime or evening	Setting problem.	Turn off the wall switch, wait 10 seconds or longer, before turning the wall switch on again.

WARRANTY

- Instructions shall caution users that modifications not approved by the party responsible for compliance could void user's authority to operate the equipment.
- NOTE: This equipment has been tested and found to comply with the limits for a Class B digital device, pursuant to part 15 of the FCC rules. These limits are designed to provide reasonable protection against harmful interference in a residential installation. This equipment generates, uses and can radiate radio frequency energy and, if not installed and used in accordance with the instructions, may cause harmful interference to radio or television reception, which can be determined by turning the equipment off and on, the user is encouraged to try to correct the interference by one or more of the following measures: Reorient or relocate the equipment into an outlet on a circuit different from that to which the receiver is connected; or consult the dealer or an experienced radio/TV technician for help.

THREE-YEAR LIMITED WARRANTY

If this product fails due to a defect in materials or workmanship within three (3) years from the date of purchase, return it along with proof of date of purchase to the retailer and it will be replaced with the same or comparable model free of charge.

This warranty is void if damage or defect has resulted from accident, abuse, misuse or faulty repair. This warranty gives you specific legal rights and you may have other rights that vary from state to state. IN NO EVENT WILL LIABILITY EXTEND TO ANY CONSEQUENTIAL, SPECIAL, INCIDENTAL OR INDIRECT DAMAGES OF ANY KIND ARISING OUT OF THE USE OR MISUSE OF THIS PRODUCT. SOME STATES DO NOT ALLOW THE EXCLUSION OR LIMITATION OF INCIDENTAL OR CONSEQUENTIAL DAMAGES SO THE ABOVE EXCLUSION OR LIMITATION MAY NOT APPLY TO YOU.

For warranty service: Call 1-800-643-0067, 8 a.m. – 6 p.m., EST, Monday – Thursday, 8 a.m. – 5 p.m., EST, Friday.

REPLACEMENT PARTS LIST

For replacement parts, call our customer service department at 1-800-643-0067, 8 a.m. – 6 p.m., EST, Monday – Thursday, 8 a.m. – 5 p.m., EST, Friday.

PART	DESCRIPTION	PART#
C	Glass	GBC180
AA	Mounting screws	90115
BB	Wire nuts	9132-P4
CC	Crossbar	9100D
DD	Decorative nuts	9003C
EE	Cage screws	9004NT-15

AA

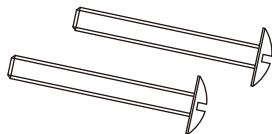

BB

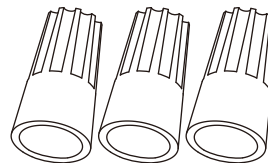

EE

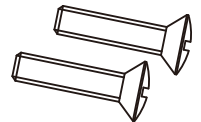

CC

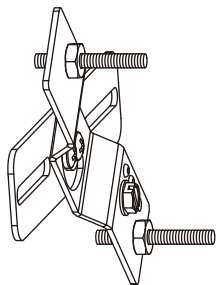

DD

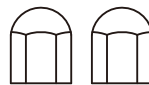

C

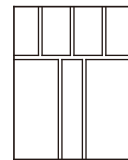

Printed in China