

PRODUCT SPECIFICATIONS

OVERALL ASSEMBLED DIMENSIONS

HEIGHT: 76.2 CM (30") (WITH SPRAYER),
HEIGHT: 71.1 CM (28") (WITHOUT SPRAYER),
WIDTH: 51 CM (20") DIA.

PUMP: UL LISTED. 12V, 60HZ, MODEL: YP-850L, 8 WATT + 2 x 0.2 WATT, HEAD: 120 CM (47-1/4"), FLOW: 600 L/H, SUBMERSIBLE FOUNTAIN PUMP.

TRANSFORMER: UL LISTED FOR WET LOCATION. INPUT: 120V, OUTPUT: 12V. 830 MA, 10 WATT.

2 LIGHTS: (2) PIECES LED LIGHTS, 12V, 0.2 WATT, 3200 K.

COLUMN: PAINTED RESIN, 36 CM (14-1/8") DIA. (TOP) x 18 CM (7") DIA. (BOTTOM) x 17 CM (6-11/16") HEIGHT, SHAPED AS SHOWN.

LID: PAINTED RESIN, 46 CM (18-1/8") DIA. x 2.5 CM (1") HEIGHT.

RESERVOIR: PAINTED RESIN, 51 CM (20") DIA. x 56.5 CM (22-1/4") HEIGHT, SHAPED AS SHOWN.

DECORATIVE RIVER STONES: A BAG OF RIVER STONES (3~5 CM, 3.3 LBS.) ARE INCLUDED.

CORD: UL LISTED, FROM PUMP TO PUMP CONNECTOR: MIN. 305 CM (10 FT.) LENGTH, BLACK COLOR. WIRES MUST BE LEAD FREE.

LABELS: MANUFACTURING DATE, MODEL # AND COUNTRY OF ORIGIN LABEL PROVIDED, WARNING LABEL FOR PARTS AND PARTS ARROW LABEL WERE STUCK ON INSIDE OF BOX.

PACKAGING AND SHIPPING DETAILS

THE FOUNTAIN IS DISASSEMBLED FOR SHIPPING. THE COMPONENT PARTS ARE CAREFULLY WRAPPED AND PLACED IN THE INNER PACKING SO THAT THEY CAN NOT MOVE DURING SHIPPING. A SMALL BAG OF SILICA IS INCLUDED IN THE PACKAGE.

THE CARTON IS MADE OF DOUBLE WALL CORRUGATED CARDBOARD "A MA A". BROWN IN COLOR. THE INNER PACKING IS DIE-CUT CARDBOARD AND/OR STYROFOAM SUFFICIENT TO PROTECT AND SECURE THE FOUNTAIN AND MUST PASS THE FEDEX AND ISTA-3A DROP TEST REQUIREMENTS.

EACH CARTON SHALL BE PRINTED WITH A LINE DRAWING AND THE KENROY HOME NAME AND LOGO, MODEL NUMBER AND FINISH, EACH CARTON SHALL BE PROVIDED A UPC LABEL. THE UPC BAR CODE AS FOLLOWS: LT=053392116415.

OTHER DETAILS

MODEL 50185LT INSTRUCTIONS ARE TO BE PACKED WITH EACH FOUNTAIN. INSTRUCTIONS MUST BE PRINTED CLEARLY ON QUALITY PAPER.

ALL VISIBLE PARTS MUST MATCH FOUNTAIN FINISH UNLESS OTHERWISE SPECIFIED.

ALL BAGS MUST BE LABELED WITH OFFICIAL "THIS BAG IS NOT A TOY" STATEMENT.

WE REQUIRED THAT A COLOR PIGMENT CLOSE TO THE FINISH COLOR OF THE FOUNTAIN MUST BE MIXED INTO THE RESIN/MATERIAL PRIOR TO THE MOLD COMPLETION. THIS IS TO ASSURE IF WE HAVE ANY PEELING OF PAINT THE RESIN IS THE SAME COLOR AS THE FINISH OF THIS ITEM.

EACH FOUNTAIN SHOULD HAVE A PIGMENT COLOR REFERENCE CHIP FOR THE UNPAINTED GOODS FOR INSPECTION.

ASSEMBLY TIME: 15 MINUTES.

THIS FOUNTAIN IS RATED FOR OUTDOOR USE.

DIMS OF BOX: 61 CM (24") LENGTH x 61 CM (24") WIDTH x 68 CM (26-3/4") HEIGHT. (CUFT.: 2.64')

NET WEIGHT: 42.9 LBS. GROSS WIEGHT: 49.5 LBS.

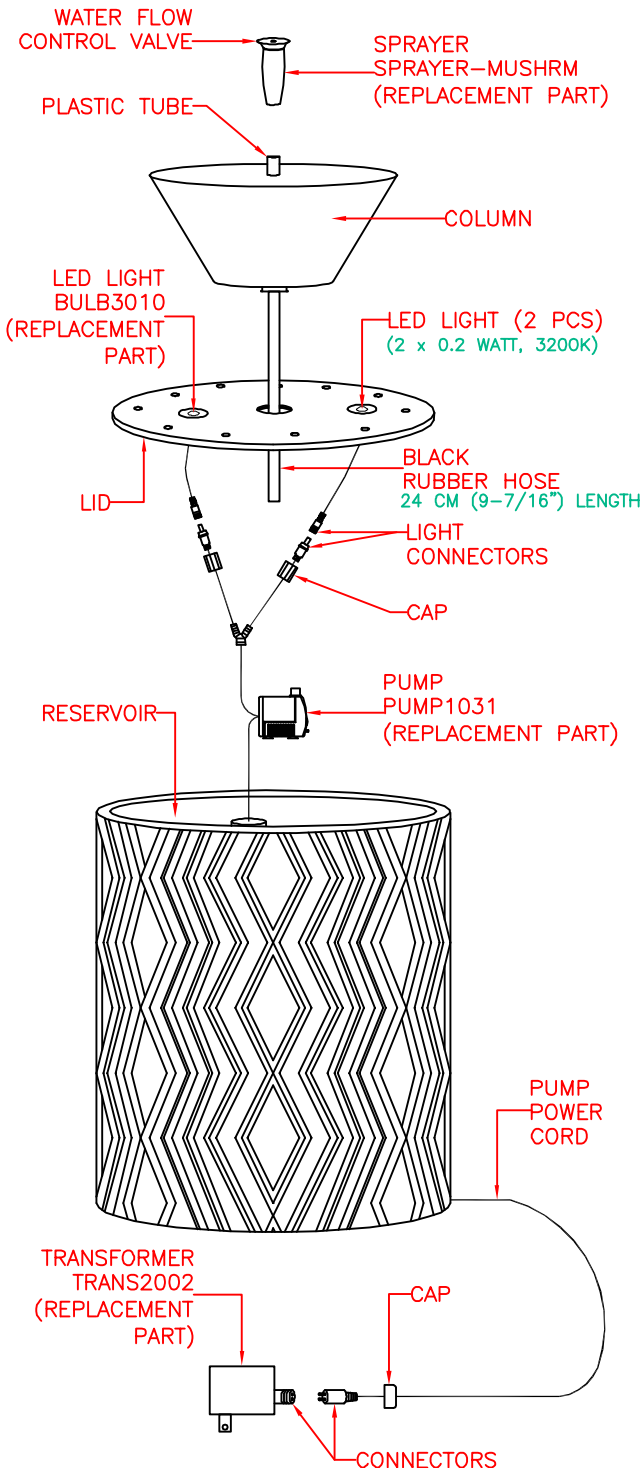

AVAILABLE PARTS ARE:

PUMP1031 (PUMP)
TRANS2002 (TRANSFORMER)
BULB3010 (LED LIGHT)
SPRAYER-MUSHRM (SPRAYER)

**KENROY
HOME**

11660 CENTRAL PARKWAY
JACKSONVILLE, FL. 32224
PHONE: 904-642-4340
FAX: 904-642-4150

THIS DOCUMENT AND THE INFORMATION THAT IT DISCLOSES IS THE EXCLUSIVE PROPERTY OF KENROY HOME. ANY REPRODUCTION OR USE OF THIS DRAWING IN PART OR IN WHOLE, WITHOUT THE EXPRESS CONSENT OF THE PROPRIETOR IS PROHIBITED. © 2011 KENROY HOME.

DATE: 6/8/2011

SCALE: NONE

DRAWN BY: JAMES

REFERENCE:
EXCARET OUTDOOR FLOOR FOUNTAIN

APPROVAL:

REVISION DATE:

REVISION DATE:

REVISION DATE:

REVISION DATE:

MODEL #:

50185

FINISH:
LIGHT TRAVATINE

PAGE: 1 OF 1