

## Features

- 3-year warranty from date of installation
- Steam generators can be installed up to 25' (7.6 m) away from steam bath area

## STEAM GENERATOR K-1714 ALSO K-1715

## Codes/Standards Applicable

Specified model meets or exceeds the following:

- UL 499
- CSA C22.2 No. 88

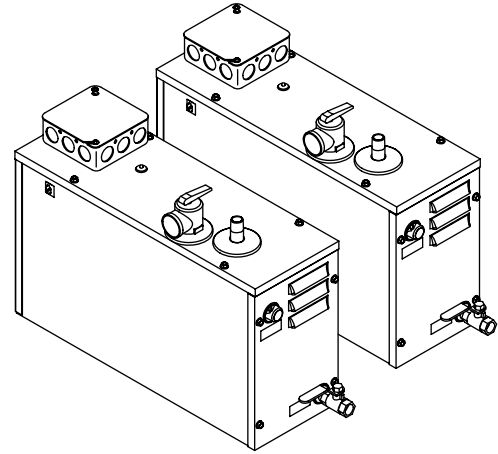

## Colors/Finishes

- NA: None applicable

## Accessories

- CP: Polished Chrome
- PB: Vibrant® Polished Brass
- Other: Refer to Price Book for additional colors/finishes

## Specified Model

Model	Description	Colors/Finishes
K-1714	18 kW Fast-Response® steam generator (qty of 2, 9 kW each)	<input type="checkbox"/> NA
K-1715	22 kW Fast-Response® steam generator (qty of 2, 11 kW each)	<input type="checkbox"/> NA

**Required Accessories:** Choose either Option 1 or Option 2 below.

*Option 1:*

K-1698	Steam control kit, power clean	<input type="checkbox"/> CP	<input type="checkbox"/> PB	<input type="checkbox"/> Other_____
--------	--------------------------------	-----------------------------	-----------------------------	-------------------------------------

*Option 2:*

K-1838	Steam adaptor kit and dual steam head <b>AND</b>	<input type="checkbox"/> CP	<input type="checkbox"/> PB	<input type="checkbox"/> Other_____
--------	--	-----------------------------	-----------------------------	-------------------------------------

K-694	Landscape digital interface <b>OR</b>			<input type="checkbox"/> Other_____
-------	---------------------------------------	--	--	-------------------------------------

K-695	Portrait digital interface			<input type="checkbox"/> Other_____
-------	----------------------------	--	--	-------------------------------------

*Optional accessories are available, refer to the Kohler Price Book.*

## Product Specification

The steam generator shall have a three-year warranty from date of installation. Steam generator shall be installed up to 25' (7.6 m) away from the steam bath area. Steam generator shall be Kohler Model K-\_\_\_\_\_-NA.

## Technical Information

Water and drain requirements:	
Water supply	3/8" line, 3/8" NPT female thread
Steam line	1/2" copper line 1/2" NPT female thread
Pressure relief valve	3/4" NPT male thread, valve supplied
Drain line	3/8" line, 3/8" NPT male thread, ball valve supplied
Generator Weight Total:	18 kW, 22 kW = 42 lbs (19 kg)

Generator Electrical Rating		
K-1714 (qty of 2, 9 kW each)	18 kW	240 V, 45 A, 50/60 Hz
K-1715 (qty of 2, 11 kW each)	22 kW	240 V, 46 A, 50/60 Hz

## Required Electrical Service

Dedicated circuit required for each generator:	
Steam generator K-1714	240 V, 60 A, 50/60 Hz
Steam generator K-1715	240 V, 60 A, 50/60 Hz

## Installation Notes

Install this product according to the installation guide.

For this steam generator, enclosure shall not exceed the maximum rating volume.

To determine the appropriate model for your installation, determine the cubic feet of your steam area by multiplying L x W x H. Compare the total to chart and use the closest match. Always round up. For every foot of ceiling height over 8' (2.45 m) use the next larger steam unit.

Steam generator model	Power Rating	Max Volume Rating
K-1714	18 kW	480 cu. ft. (14 cu. m)
K-1715	22 kW	634 cu. ft. (18 cu. m)

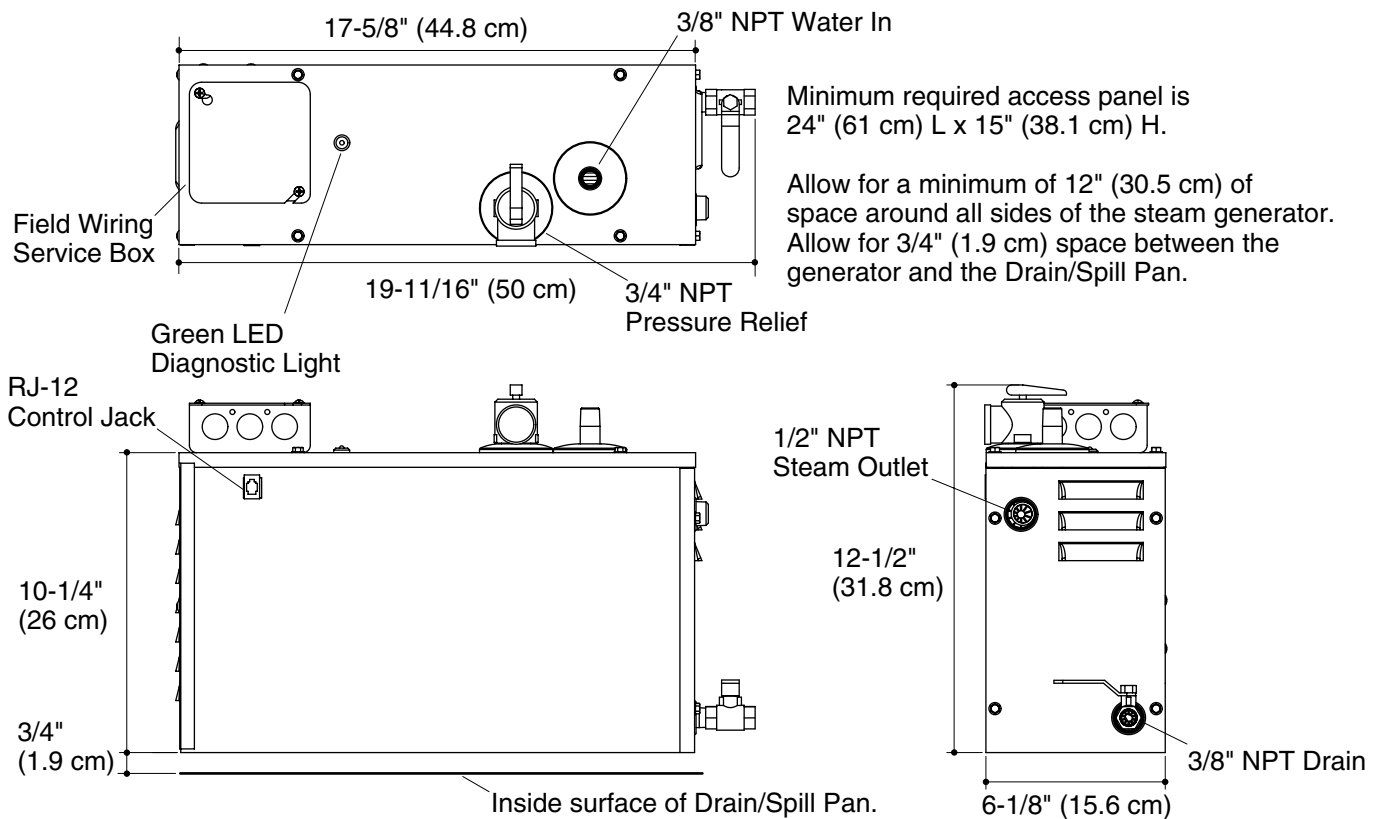

## Product Diagram