



Portfolio® is a registered trademark of LF, LLC. All rights reserved.

ITEM #0031473

3-LIGHT VANITY BAR

MODEL #FV11-114

Français p. 8

Español p. 15

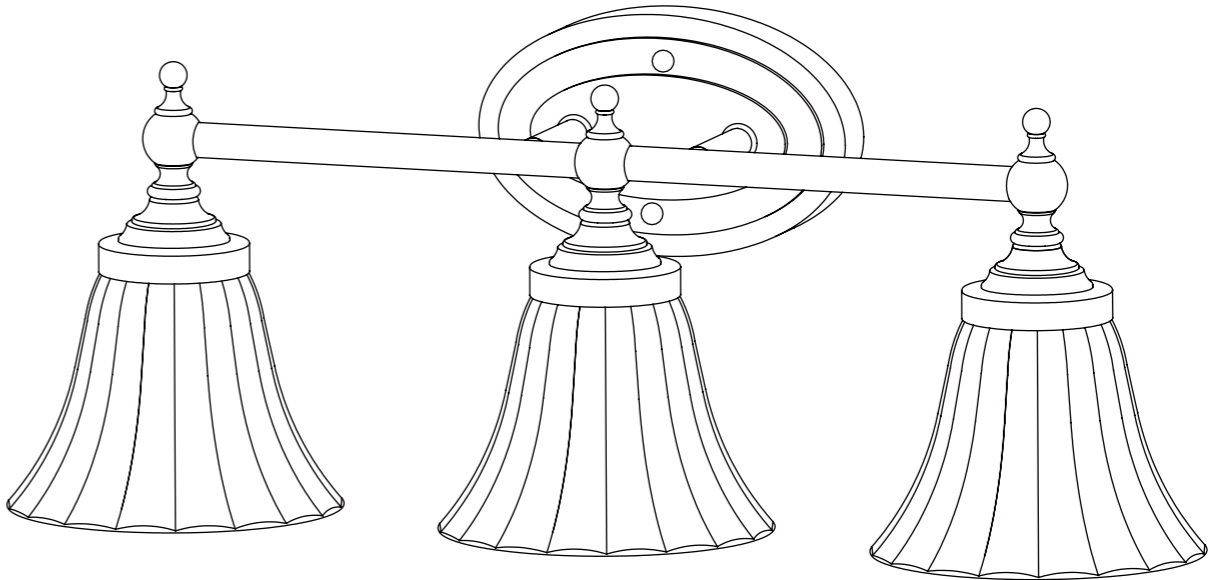

ATTACH YOUR RECEIPT HERE

Serial Number _____ Purchase Date _____



Intertek



Questions, problems, missing parts? Before returning to your retailer, call our customer service department at 1-800-643-0067, 8 a.m. - 6 p.m., EST, Monday - Thursday, 8 a.m. - 5 p.m., EST, Friday.



PACKAGE CONTENTS

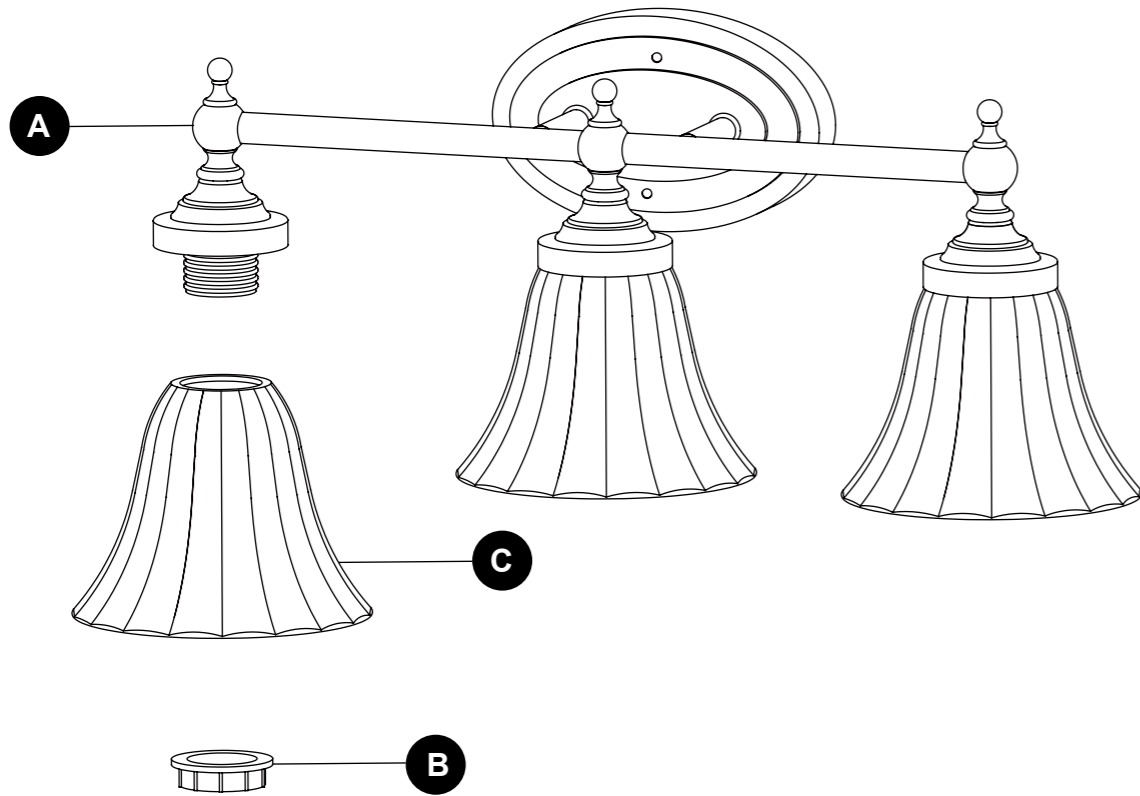

| PART | DESCRIPTION | QUANTITY |
|------|---|----------|
| A | Fixture | 1 |
| B | Socket ring (preassembled to Fixture (A)) | 3 |
| C | Glass shade | 3 |

HARDWARE CONTENTS (shown actual size)

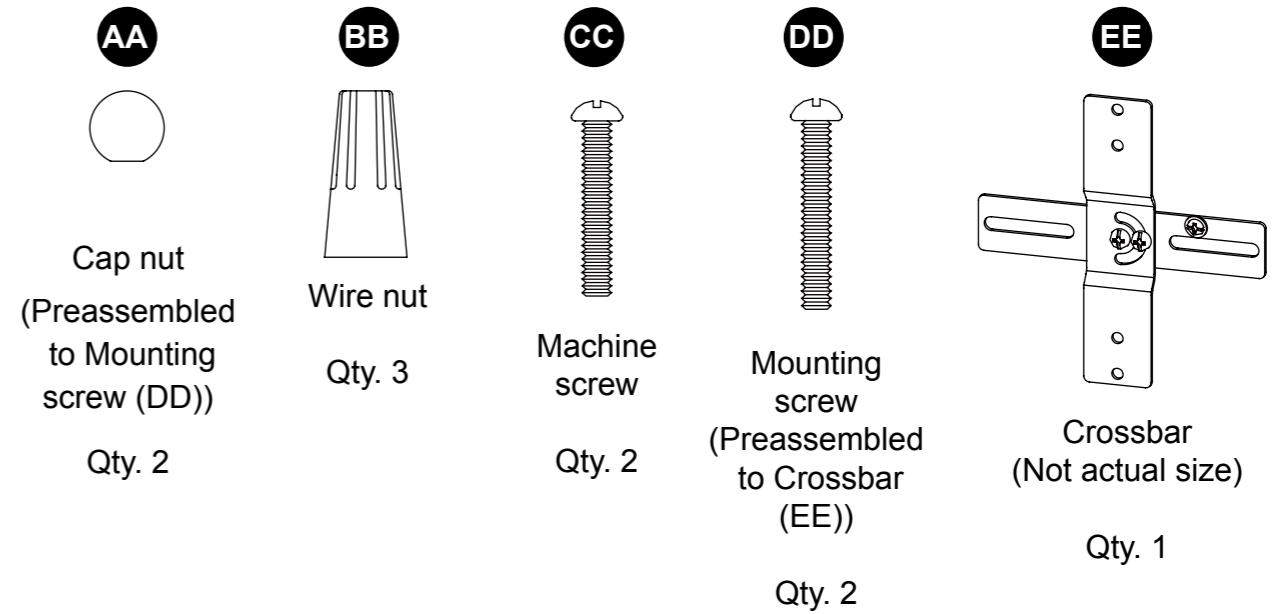

! SAFETY INFORMATION

Please read and understand this entire manual before attempting to assemble, operate or install the product.

! WARNING

- TURN OFF ELECTRICITY at main fuse box (or circuit breaker box) before beginning installation by removing fuse (or switching off circuit breaker).
- MINIMUM 90°C SUPPLY CONDUCTORS.

CAUTION

- CONSULT A QUALIFIED ELECTRICIAN TO ENSURE CORRECT BRANCH CIRCUIT CONDUCTOR.
- If in doubt about electrical installation, consult a licensed electrician.

PREPARATION

Before beginning assembly of product, make sure all parts are present. Compare parts with package contents list and hardware contents list. If any part is missing or damaged, do not attempt to assemble the product.

Estimated Assembly Time: 25 minutes



Tools Required for Assembly (not included): Flathead screwdriver, Phillips screwdriver, Pliers, Electrical tape, Wire cutters, Safety glasses.

Helpful Tools (not included): Wire strippers.

ASSEMBLY INSTRUCTIONS

1. Remove cap nuts (AA) from mounting screws (DD) preassembled to crossbar (EE). Attach crossbar (EE) to the outlet box (not included) with machine screws (CC). Note: The mounting screws (DD) should protrude away from the outlet box.

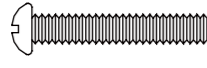
Hardware Used

| | | |
|--------------------------|---|-----|
| AA Cap nut |  | x 2 |
| CC Machine screw |  | x 2 |
| DD Mounting screw |  | x 2 |
| EE Crossbar |  | x 1 |

2. Strip 3/4 in. of insulation from wire ends. Twist stripped ends together with pliers (not included), black to black (power) and white to white (neutral). Attach copper wire to ground wire. **Helpful hint:** If necessary, attach copper ground wire to grounded junction box.

3. Attach wire nuts (BB). Tape wire nuts (BB) and wires together.

Hardware Used

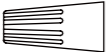

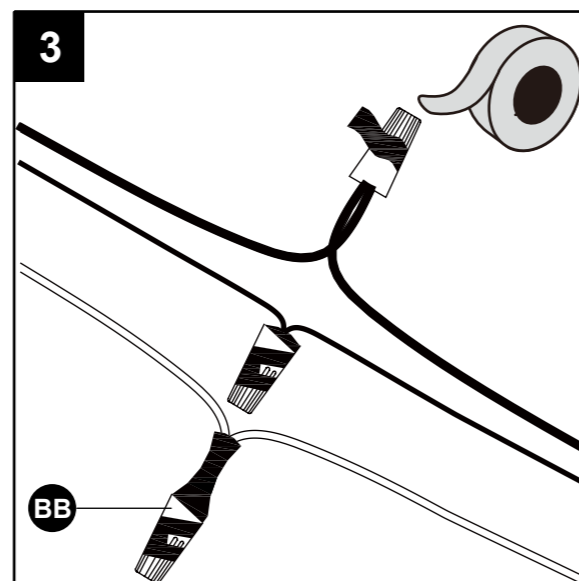
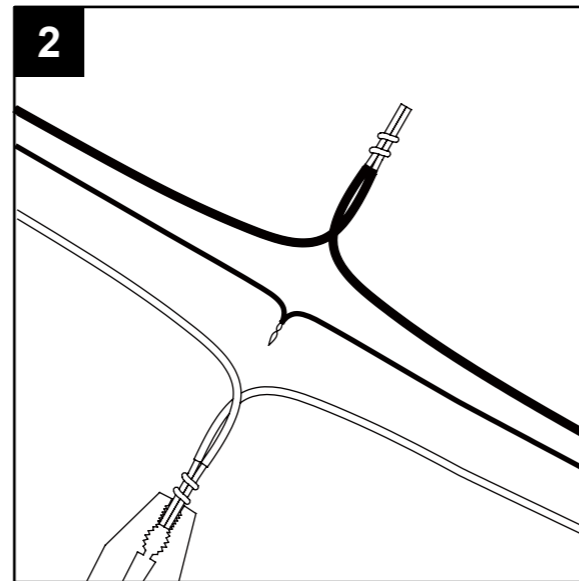
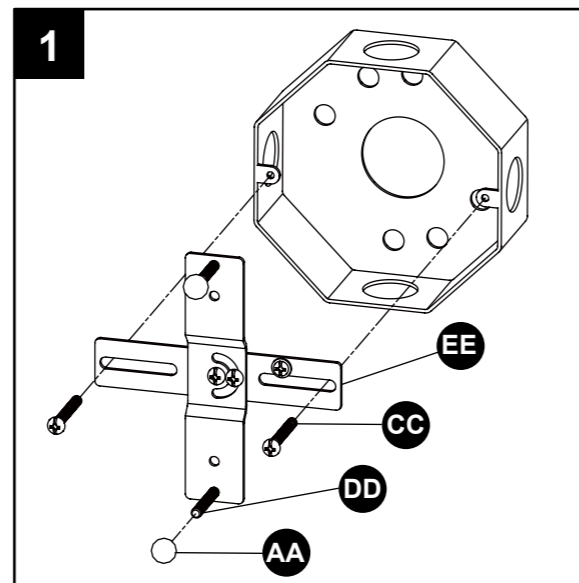
| | | |
|--------------------|---|-----|
| BB Wire nut |  | x 3 |
|--------------------|---|-----|



ASSEMBLY INSTRUCTIONS

4. Place fixture (A) onto mounting screws (DD). Secure with cap nuts (AA). Note: The fixture (A) can be installed with the sockets facing up or down.

Hardware Used

| | | |
|--------------------------|---|-----|
| AA Cap nut |  | x 2 |
| DD Mounting screw |  | x 2 |

5. Remove socket rings (B). Install glass shades (C) over sockets of fixture (A), then secure with socket rings (B).

6. Install light bulbs (not included). Use three 60-watt max. standard-base bulbs or three 13-watt standard-base CFL bulbs.

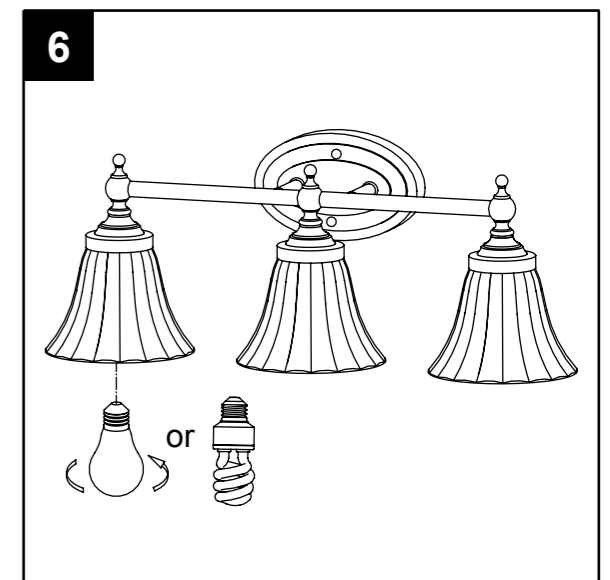
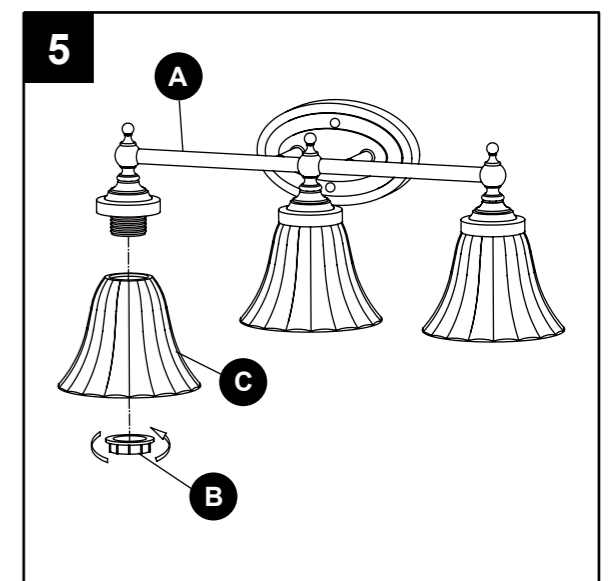
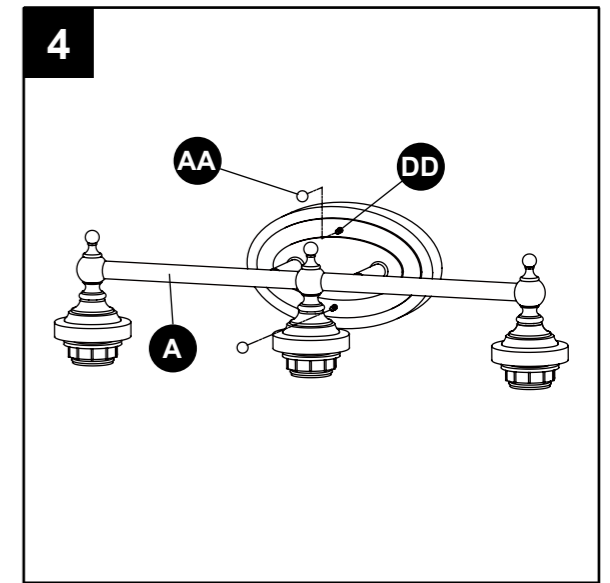

CARE AND MAINTENANCE

- Shut off main power supply before wiping product with damp cloth or window cleaner. Do not use abrasives.

TROUBLESHOOTING

| PROBLEM | POSSIBLE CAUSE | CORRECTIVE ACTION |
|--|---|--|
| Bulb won't light. | <ol style="list-style-type: none"> 1. Bulb is burned out. 2. Power is off. 3. Faulty wire connection. 4. Faulty switch. | <ol style="list-style-type: none"> 1. Replace light bulb. 2. Make sure power supply is on. 3. Check wiring. 4. Test or replace switch. |
| Fuse blows or circuit breaker trips when light is turned on. | Crossed wires or power wire is grounding out. | Check wire connections. |

WARRANTY

The manufacturer warrants all of its lighting fixtures against defects in materials and workmanship for one (1) year from the date of purchase. If within this period the product is found to be defective in material or workmanship, the product must be returned, with a copy of the original sales receipt as proof of purchase in the original carton, to the place of purchase. The manufacturer will, at its option, repair, replace or refund the original purchase price to the consumer. This warranty does not cover fixtures becoming defective due to misuse, accidental damage, improper handling and/or installation and specifically excludes liability for direct, incidental or consequential damages. As some states do not allow exclusions or limitations on an implied warranty, the above exclusions and limitations may not apply to you. This warranty gives you specific legal rights, and you may have other rights that vary from state to state.

REPLACEMENT PARTS LIST

For replacement parts, call our customer service department at 1-800-643-0067, 8 a.m. - 6 p.m., EST, Monday - Thursday, 8 a.m. - 5 p.m., EST, Friday.

| PART | DESCRIPTION | PART # |
|------|----------------|------------|
| AA | Cap nut | 110-100900 |
| BB | Wire nut | 375-022000 |
| CC | Machine screw | 109-042600 |
| DD | Mounting screw | 109-042800 |
| EE | Crossbar | 152-103000 |

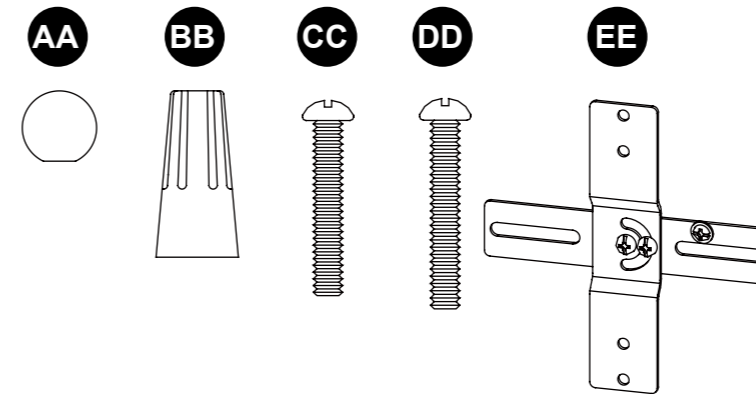

Printed in China

Portfolio® is a registered trademark of LF, LLC. All rights reserved.