



OPERATOR'S MANUAL

5-Gallon Pancake Air Compressor

Item #2275



09/10

IMPORTANT:



Your new WEN® tool and/or equipment has been engineered and manufactured to high standards for dependability, ease of operation, and operator safety. Properly cared for, it will give you years of rugged, trouble-free performance.

Pay close attention to the Rules for Safe Operation and Warnings. If you use your tool and/or equipment properly and only for what it is intended, you will enjoy years of safe, reliable service.



It's not how, it's WEN the project get's done!
Contact us for product questions or technical support.



WenProducts.com



[800-232-1195](tel:800-232-1195) M-F 8-5 (CST)



techsupport@wenproducts.com

AIR COMPRESSOR IDENTIFICATION

For information and questions please contact customer service at 1-800-232-1195. Please fill out the information below and have it accessible prior to calling. For the Serial Number refer to the specifications sticker on your Air Compressor.

DATE OF PURCHASE: _____

PURCHASED FROM: _____

ITEM #: _____

SERIAL NUMBER: _____



TABLE OF CONTENTS

Specifications 3

Important Safety Instructions 4

General Safety Instructions 4–6

Air Compressor Safety Instructions 6–7

Electrical Instructions 7–9

Components 10

Assembly Instructions. 11

Operation 12–13

Maintenance 13–15

Troubleshooting. 16

Service 16

Exploded View 17

Parts List 18

Warranty 19

SPECIFICATIONS

5-Gallon Pancake Air Compressor

Item #:	2275
Motor:	120V, 60Hz, 13 Amps
Pressure Range:	85–125 psi
Air Flow:	4.2 CFM @ 40 psi 3.2 CFM @ 90 psi
Air Outlet Size:	1/4" NPT
Tank Capacity:	5-Gallons
Weight:	48 lbs.



IMPORTANT SAFETY INSTRUCTIONS

1. The purpose of safety symbols is to attract your attention to possible dangers. The safety symbols, and the explanations with them, deserve your careful attention and understanding. The safety warnings do not by themselves eliminate any danger. The instructions or warnings they give are not substitutes for proper accident prevention measures.



WARNING: This is a safety alert symbol. It is used to alert you to potential personal injury hazards. Obey all safety rules that follow this symbol to avoid possible injury or death.

Note: Advises you of information or instructions vital to the operation or maintenance of the equipment.

2. Servicing requires extreme care and knowledge and should be performed only by a qualified service technician. For service we suggest you return the tool/equipment to WEN PRODUCTS for repair. When servicing, use only identical WEN replacement parts.

3. READ ALL INSTRUCTIONS BEFORE USING YOUR AIR COMPRESSOR.

4. Failure to follow all instructions listed below may result in electrical shock, fire and/or serious personal injury.



WARNING: Do not attempt to operate this tool/equipment until you have read thoroughly and understand completely all instructions, safety rules, contained in this manual. Failure to comply can result in accidents involving fire, electric shock, or serious personal injury. Save this operator's manual and review frequently for continuing safe operation and instructing others who may use this tool/equipment.

5. Safe operation of this tool/equipment requires that you read and understand this operator's manual and all labels affixed to the tool/equipment. Safety is a combination of common sense, staying alert and knowing how your tool/equipment works.

GENERAL SAFETY INSTRUCTIONS



WARNING: Read all safety warnings and instructions. Failure to follow the warnings and instructions may result in electric shock, fire and/or serious injury.

SAVE ALL WARNINGS AND INSTRUCTIONS FOR FUTURE REFERENCE.



Work Area Safety

1. Keep work area clean and well lit. Cluttered or dark areas invite accidents.
2. Do not operate your Air Compressor in explosive atmospheres, such as in the presence of flammable liquids, gases or dust. Air Compressor motors produce sparks which may ignite the dust or fumes.
3. Keep children and bystanders away from an operating Air Compressor.

Electrical Safety

1. Air Compressor plugs must match the outlet. Never modify the plug in any way. Do not use any adapter plugs with grounded Air Compressors. Standard plugs and matching outlets will reduce the risk of electric shock.
2. Do not expose your Air Compressor to rain or wet conditions. Water entering your Air Compressor will increase the risk of electric shock.
3. Do not abuse the cord. Never use the cord for unplugging your Air Compressor. Keep the cord away from heat, oil, sharp edges or moving parts. Damaged or entangled cords increase the risk of electric shock.

Personal Safety

1. Stay alert, watch what you are doing and use common sense when operating your Air Compressor. Do not use your Air Compressor while you are tired or under the influence of drugs, alcohol or medication. A moment of inattentiveness while operating your Air Compressor may result in serious personal injury.
2. Use protective safety equipment. Always wear ANSI-approved eye protection during setup and use.
3. Prevent unintentional starting. Ensure the switch is in the OFF position before connecting to power source or moving your Air Compressor.

Air Compressor Use and Care

1. Do not use your Air Compressor if the switch does not turn ON and OFF. An Air Compressor that cannot be controlled with the switch is dangerous and must be repaired.
2. Disconnect the plug from the power source before making any adjustments, changing accessories, or storing your Air Compressor. This preventive safety measures reduce the risk of starting your Air Compressor accidentally.



3. Store your Air Compressor out of the reach of children and do not allow people unfamiliar with your Air Compressor or these instructions to operate it. An Air Compressor is dangerous in the hands of untrained users.
4. Maintain your Air Compressor. Keep your Air Compressor clean for maximum performance. Follow the instructions for lubricating and changing accessories. Keep your Air Compressor dry, clean and free from oil and grease. Check for misalignment or binding of moving parts, breakage of parts and any other condition that may affect your Air Compressor's operation. If damaged, have your Air Compressor repaired professionally before use. Many accidents are caused by a poorly maintained Air Compressor.
5. Use your Air Compressor in accordance with these instructions, taking into account the working conditions and the work to be performed. Use of your Air Compressor for operations different from those intended could result in a hazardous situation.

Service

Have your Air Compressor serviced by a qualified professional repair person using only identical replacement parts. This will ensure that the safety of your Air Compressor is maintained.

AIR COMPRESSOR SAFETY INFORMATION

1. RISK OF FIRE OR EXPLOSION – Do not spray flammable liquid in a confined area or towards a hot surface. The spray area must be well-ventilated. Do not smoke while spraying or spray where spark or flame is present.
2. ARCING PARTS – Keep your Air Compressor at least 20 feet away from explosive vapors, such as when spraying with a spray gun.
3. RISK OF BURSTING – Do not adjust regulator higher than marked maximum pressure of attached pneumatic tool/equipment.
4. RISK OF INJURY – Do not direct air stream at people or animals.
5. Do not use to supply breathing air.
6. Do not leave your Air Compressor unattended for an extended period while plugged in. Unplug compressor after use.
7. Keep your Air Compressor well-ventilated and do not cover during use.
8. Drain tank daily or after use. Internal rust causes tank failure and explosion.
9. Your Air Compressor's cylinder head and air lines get hot during operation. Do not touch or allow children nearby during or immediately following operation.
10. Do not use the air hose to move your Air Compressor.



11. Release the pressure in the storage tank before moving.
12. The use of accessories or attachments not recommended by the manufacturer may result in bodily injury.
13. All air line components, including hoses, pipe, connectors, and filters must be rated for a minimum working pressure of 150% of the maximum system pressure.
14. Industrial applications must follow OSHA guidelines.
15. This product is not a toy. Keep it out of reach from children.
16. People with pacemakers should consult their physician(s) before use. Electromagnetic fields in close proximity to heart pacemaker could cause pacemaker interference or pacemaker failure.



WARNING: The brass components of this product contain lead, a chemical known to the State of California to cause birth defects (or other reproductive harm). (California Health & Safety code 25249.5, et seq.)

17. The warnings, precautions, and instructions discussed in this Operator's Manual cannot cover all the possible conditions and situations that may occur. It must be understood by the operator that common sense and caution are factors which cannot be built into this product, but must be supplied by the operator.

ELECTRICAL INSTRUCTIONS

Grounding Instructions

1. IN THE EVENT OF A MALFUNCTION OR BREAKDOWN, grounding provides the path of least resistance for electric current and reduces the risk of electric shock. This tool/equipment is equipped with an electric cord that has an equipment grounding conductor and a grounding plug. The plug **MUST** be plugged into a matching outlet that is properly installed and grounded in accordance with **ALL** local codes and ordinances.
2. **DO NOT MODIFY THE PLUG PROVIDED.** If it will not fit the outlet, have the proper outlet installed by an electrician.
3. **IMPROPER CONNECTION** of the equipment grounding conductor can result in electric shock. The conductor with the green insulation (with or without yellow stripes) is the equipment grounding conductor. If repair or replacement of the electric cord or plug is necessary, **DO NOT** connect the equipment grounding conductor to a live terminal. **CHECK** with a licensed electrician or service personnel if you do not completely understand the grounding instructions, or if you are not sure if the tool/equipment is properly grounded.



4. USE ONLY THREE WIRE EXTENSION CORDS with have 3-prong plugs and 3-prong outlets that accept the tool/equipment's plug. Repair or replace damaged or worn cords immediately.
5. CAUTION: In all cases, make certain the outlet is properly grounded. If you are not sure if it is, have a licensed electrician check the outlet.



WARNING: This tool/equipment is for indoor use only. Do not expose to rain or use in damp locations.

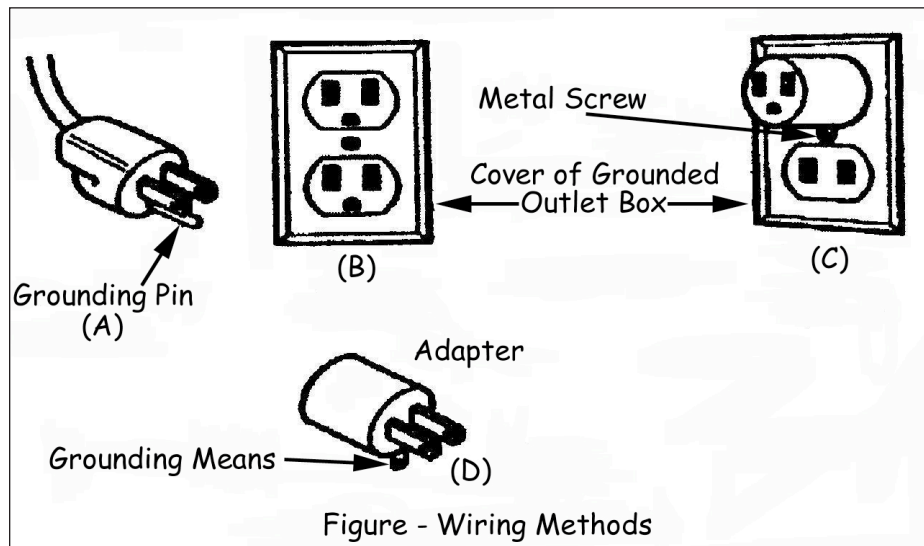

Fig. 1

1. Tools/equipment with three wire grounding plugs (Fig. 1, A) are intended for use on a circuit that has an outlet that looks like the one illustrated (Fig. 1, B).
2. A temporary adapter (Fig. 1, B & C) may be used to connect this plug to a 2-pole receptacle (Fig. 1, B) if a properly grounded outlet is not available.
3. The temporary adapter should be used only until a properly grounded outlet can be installed by a qualified electrician.
4. The green colored rigid ear, lug, etc. extending from the adapter must be connected to a permanent ground such as a properly grounded outlet box (Fig. 1, D).



Extension Cord Guidelines

Make sure your extension cord is in good condition. When using an extension cord, be sure to use one heavy enough to carry the current your product will draw. An undersized cord will cause a drop in line voltage resulting in loss of power and overheating. The table below shows the correct size to be used according to cord length and nameplate ampere rating. If in doubt, use the next heavier gauge. The smaller the gauge number, the heavier the cord.

Minimum gauge for Extension Cords (AWG)					
(When using 120V only)					
Ampere Rating		Total Length of Cord in feet			
More Than	Not More Than	25	50	100	150
0	6	18	16	16	14
6	10	18	16	14	12
10	12	16	16	14	12
12	16	14	12	Not Recommended	

1. Be sure your extension cord is properly wired and in good condition. Always replace a damaged extension cord or have it repaired by a qualified person before using it.
2. Protect your extension cords from sharp objects, excessive heat and damp or wet areas.
3. Use a separate electrical circuit for your tools. This circuit must not be less than a #12 wire and should be protected with a 20 Amp time delayed fuse.
4. Before connecting the motor to the power line, make sure the switch is in the OFF position and the electric current is rated the same as the current stamped on the motor nameplate. Running at a lower voltage will damage the motor.



WARNING: This tool must be grounded while in use to protect the operator from electrical shock.



COMPONENTS



Fig. 2

- | | |
|-------------------------|-------------------------|
| 1 – Carrying Handle | 2 – Air Filter |
| 3 – ON/OFF Switch | 4 – Regulator |
| 5 – Air Flow Valve | 6 – Air Regulator Gauge |
| 7 – Tank Pressure Gauge | 8 – Drain Valve |
| 9 – Rubber Foot | |



ASSEMBLY INSTRUCTIONS

Unpacking

1. When unpacking, make sure that the machine is intact and undamaged.
2. Please check that the following items are included with your Air Compressor.

– Oil Bottle

– Air Filter

– Oil Breather Cap

3. If any parts are missing or broken, please call our customer services at 1-800-232-1195.
4. Your Air Compressor requires minimum assembly. Remove the parts from the carton.



Fig. 3

Air Filter Installation (Fig. 3)

This Air Compressor is shipped with a plastic plug in the air filter hole. Before operating this unit, remove the plug and connect the air filter (Fig 3).

Add Oil and Install Oil Breather Cap (Fig. 4 & 5)

1. Your Air Compressor ships without oil in the Crankcase.

Note: BEFORE STARTING YOU AIR COMPRESSOR YOU MUST ADD OIL TO THE CRANKCASE AS DESCRIBED BELOW.

2. Place your Air Compressor on level ground.
3. Remove the Oil Shipping Plug from the Oil Fill Hole located on the top of the case cover at the rear of the Air Compressor (Fig. 5).
4. Slowly pour the oil into the Oil Fill Hole until the oil level rises to the center of the red dot on the Oil Sight Glass (Fig. 5).
5. Install the Oil Breather Cap into the Oil Fill Hole.

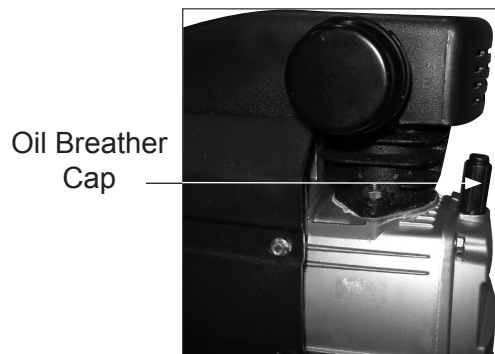
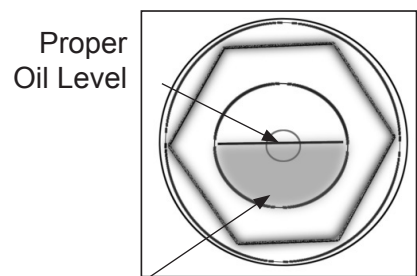

Fig. 4



Proper Oil Level
Minimum Oil Level

Fig. 5



OPERATION

BEFORE OPERATING YOUR NEW AIR COMPRESSOR complete the following steps.

1. Check that all nuts and bolts are secure.
2. Make sure the oil has been properly added to your Air Compressor.
3. Place your Air Compressor on a firm, level surface in a clean, dry, well ventilated area.
4. Your Air Compressor should be located 12 to 18 inches from walls or any other obstruction which would interfere with airflow. Your Air Compressor should be located in a temperature controlled area between 32° and 95°F.
5. Your Air Compressor is designed with heat dissipation fins which allow for proper cooling. Keep the fins and all other parts clean from dust or dirt. A clean Air Compressor runs cooler and provides longer service.
6. Do not place rags, containers or other material on top of your Air Compressor.

Power Source Connection

Your Air Compressor is designed to operate on a properly grounded 120 volt, 60HZ, single phase, alternating current (AC) power source with a fused 20 Amp time delayed fuse or circuit breaker. It is recommended that a qualified electrician verify the ACTUAL VOLTAGE at the receptacle into which the unit will be plugged and confirm that the receptacle is properly fused and grounded. The use of the proper circuit size can eliminate nuisance circuit breaker tripping while operating your Air Compressor. For electrical details see pages 7–9.

Initial Start-Up Procedures

1. Open the Air Tank Drain Valve to permit air to escape, preventing air pressure buildup in the Air Tank.
2. Run the compressor for a minimum of 20 minutes in this “no-load” position to lubricate the piston.
3. Close Air Tank Drain Valve. Your compressor is ready for use.
4. See pneumatic tool instructions for instructions on how to connect the tool to your Air Compressor.

Depending on the CFM draw of the tools being operated, your new Air Compressor can be used for operating paint sprayers, air tools, grease guns, airbrushes, caulking guns, abrasive blasters, tire & plastic toy inflation, spraying weed killer and insecticides, etc. Proper adjustment of the Air Pressure Regulator is necessary for all of these operations. Refer to the air pressure specifications provided with the tool you are using.



General Overview

1. To compress air, the piston moves up and down in the cylinder. On the down stroke air is drawn in through the valve inlet. The discharge valve remains closed. On the upstroke of the piston air is compressed.
2. The inlet valve closes and air is forced out through the discharge valve, through the Check Valve, and into the Air Tank.
3. Working air is not available until the Air Compressor has raised the tank pressure above that required at the air service connection.
4. The air inlet filter openings must be kept clear of obstructions, which could reduce air delivery of the Air Compressor.

Air Pressure Adjustment

1. Your Air Compressor is supplied with an Air Pressure Regulator. This Regulator adjusts the air pressure.
2. To increase air pressure, turn the Air Regulator clockwise.
3. To decrease air pressure, turn the Air Regulator counterclockwise.
4. The Air Regulator gauge will show the current pressure selected.

MAINTENANCE

Daily (or before each use)

1. Check oil level.
2. Check for any unusual noise or vibration.
3. Be sure all nuts and bolts are tight.

Weekly

1. Clean breather hole on Oil Breather Cap.
2. Drain water from the Air Tank through the Drain Valve.
3. Keep Air Filter clean at all times. Do not operate the Air Compressor with the air filter removed.
4. A dirty Air Filter will not allow your Air Compressor to operate at full capacity. Before you use your Air Compressor, check the Air Filter to be sure it is clean. If it is dirty replace the filter element.



Monthly

Inspect air system for leaks by applying soapy water to all joints. Tighten these joints if leaks are discovered.

6 Months (or after 250 hours of operation - whichever comes first)

Change Air Compressor Oil.

Note: Change the oil more often if your Air Compressor is used near paint spraying operations or in dusty environments.

Checking the Air Compressor Oil

1. Place your Air Compressor on a level surface. The oil level should be at the red dot on the Oil Sight Glass.
2. If oil level is low, remove Oil Breather Cap and add enough oil to bring the oil level to the red dot on the Oil Sight Glass.

Changing the Air Compressor Oil

Note: This compressor uses only SAE 5W-30 motor oil.

1. Remove the Oil Sight Glass by turning counterclockwise with wrench.

Note: Oil will begin to drain as the Oil Sight Glass is loosened. Make sure a funnel and oil pan are in place BEFORE loosening the Oil Sight Glass.

2. Once the Oil Sight Glass is removed, tilt your Air Compressor forwards to allow all the oil to drain out of the Crankcase.
3. Once the oil is drained, replace the Oil Sight Glass and securely tighten in place with a wrench. Be careful not to over tighten the Oil Sight Glass, as this could damage the rubber seal.
4. Place your Air Compressor on level surface.
5. Remove the Oil Breather Cap.
6. Slowly pour the oil into the oil fill hole, until the oil level rises to the center of the red dot on the Oil Sight Glass.
7. Install the Oil Breather Cap into the oil fill hole.
8. Always inspect Air Compressor before use, and make sure it is in good working condition. Use compressed air to clean the machine where possible.



9. Check the power cable to make sure it is intact and free from cracks, bare wires etc.
10. Avoid using solvents when cleaning plastic parts, most plastics are susceptible to damage from the various types of commercial solvents.



TROUBLESHOOTING

Problem	Cause	Solution
Air Compressor will not start	Thermal Overload	Allow to cool and push the reset button located in the Crankcase close to the Air Filter.
	Blown fuse or circuit breaker tripped.	Replace or reset fuse/circuit breaker.
	Loose electrical connections	Check wiring connections
Low pressure	Restricted Air Filter	Replace Air Filter
	Defective Check Valve	Replace Check Valve
	Air leak in Safety Valve	Check valve by pulling on ring. If condition persists, replace valve
Safety valve releasing	Defective Pressure Switch	Replace pressure switch
Oil discharge in Air Compressor	Too much oil in Crankcase	Drain Crankcase and refill to proper level on Oil Sight Glass
	Compressor overheated	Reduce air pressure regulation.
	Restricted Oil Breather Cap	Clean or replace Oil Breather Cap.

**If trouble persists please call our customer service
1-800-232-1195, M–F 8–5 (CST)**

SERVICE

1. Mechanical and/or electrical tool service is to be performed only by professional qualified repair personnel. Service performed by unqualified personnel may result in a risk of injury.
2. When servicing a tool, use only identical replacement parts. Use of unauthorized parts or failure to follow maintenance instructions may create a risk of electrical shock or injury.

NOTE: If any parts are damaged or missing, do not attempt to plug in the power cord and turn the switch on until the damaged or missing parts are obtained and are installed correctly.



EXPLODED VIEW

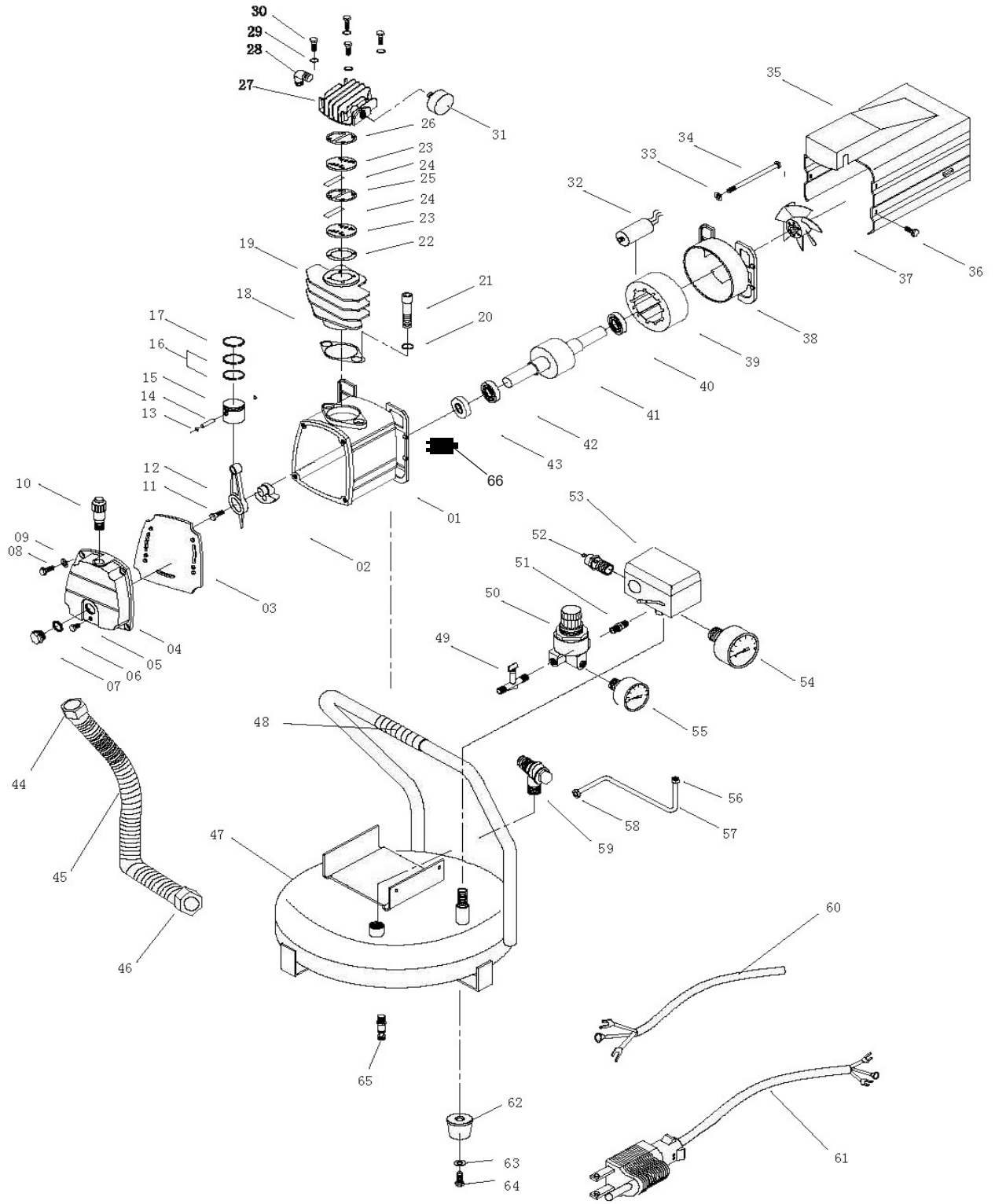



PARTS LIST

Part #	Stock #	Description	Part #	Stock #	Description
1	2274-001	Crankcase	34	2274-034	Bolt
2	2274-002	Crank Shaft	35	2274-035	Motor Cover
3	2274-003	Gasket	36	2274-036	Bolt
4	2274-004	Crankcase Cover	37	2274-037	Fan
5	2274-005	Bolt	38	2274-038	Motor Back Cover
6	2274-006	O-ring	39	2274-039	Stator
7	2274-007	Oil Sight Glass	40	2274-040	Bearing
8	2274-008	Bolt	41	2274-041	Rotor
9	2274-009	Washer	42	2274-042	Bearing
10	2274-010	Oil Breather Cap	43	2274-043	Oil Seal
11	2274-011	Bolt	44	2275-044	Exhaust Pipe Nut
12	2274-012	Connecting Rod	45	2275-045	Exhaust Pipe
13	2274-013	Circle Clip	46	2275-046	Exhaust Pipe Nut
14	2274-014	Piston Pin	47	2275-047	Air Tank
15	2274-015	Piston	48	2275-048	Carrying Handle
16	2274-016	Piston Oil Ring	49	2275-049	Air Flow Valve
17	2274-017	Piston Ring	50	2274-062	Regulator
18	2274-018	Gasket	51	2275-051	Connector
19	2274-019	Cylinder	52	2274-049	Safety Valve
20	2274-020	Washer	53	2275-053	Pressure Switch
21	2274-021	Bolt	54	2274-064	Tank Pressure Gauge
22	2274-022	Valve Gasket	55	2274-061	Air Regulator Gauge
23	2274-023	Valve	56	2275-056	Unloading Nut
24	2274-024	Valve Plate	57	2275-057	Unloading Pipe
25	2274-025	Gasket	58	2275-058	Unloading Nut
26	2274-026	Cylinder Head Gasket	59	2274-057	Check Valve
27	2274-027	Cylinder Head	60	2275-060	Wire Cable
28	2274-028	Elbow Connector	61	2275-061	Power Cord
29	2274-029	Washer	62	2275-062	Rubber Foot
30	2274-030	Bolt	63	2275-063	Washer
31	2274-031	Air Filter	64	2275-064	Bolt
32	2274-032	Capacitor	65	2274-050	Drain Valve
33	2274-033	Washer	66	2274-069	Overload Reset



ONE (1) YEAR LIMITED WARRANTY

WEN® is committed to building tools that are dependable for years. Our warranties are consistent with our commitment and dedication to quality.

ONE (1) YEAR LIMITED WARRANTY OF WEN PRODUCTS FOR HOME USE.

GREAT LAKES TECHNOLOGIES, LLC ("Seller") warrants to the original purchaser only, that all WEN consumer power tools will be free from defects in material or workmanship for a period of one (1) year from date of purchase. Ninety (90) days for all WEN Products, if the tool is used for professional or commercial use.

SELLER'S SOLE OBLIGATION AND YOUR EXCLUSIVE REMEDY under this One (1) Year Limited Warranty and, to the extent permitted by law, any warranty or condition implied by law, shall be the repair or replacement of parts, without charge, which are defective in material or workmanship and which have not been misused, carelessly handled, or misrepaired by persons other than Seller or Authorized Service Center. To make a claim under this Limited Warranty, you must return the entire power tool product; transportation prepaid, to Great Lakes Technologies, LLC, 501 Davis Road, Elgin, IL 60123. Include a legible copy of the original receipt, which lists the date of purchase (month and year) and the name of the company purchased from.

THIS LIMITED WARRANTY DOES NOT APPLY TO ANY ACCESSORY ITEMS INCLUDED WITH THE TOOL SUCH AS CIRCULAR SAW BLADES, DRILL BITS, ROUTER BITS, JIGSAW BLADES, SANDING BELTS, GRINDING WHEELS AND OTHER RELATED ITEMS OR TO ANY REPLACEMENT PARTS LISTED UNDER MAINTENANCE.

ANY IMPLIED WARRANTIES SHALL BE LIMITED IN DURATION TO ONE (1) YEAR FROM DATE OF PURCHASE. SOME STATES IN THE U.S. AND SOME CANADIAN PROVINCES DO NOT ALLOW LIMITATIONS ON HOW LONG AN IMPLIED WARRANTY LASTS, SO THE ABOVE LIMITATION MAY NOT APPLY TO YOU.

IN NO EVENT SHALL SELLER BE LIABLE FOR ANY INCIDENTAL OR CONSEQUENTIAL DAMAGES (INCLUDING BUT NOT LIMITED TO LIABILITY FOR LOSS OF PROFITS) ARISING FROM THE SALE OR USE OF THIS PRODUCT. SOME STATES IN THE U.S. AND SOME CANADIAN PROVINCES DO NOT ALLOW THE EXCLUSION OR LIMITATION OF INCIDENTAL OR CONSEQUENTIAL DAMAGES, SO THE ABOVE LIMITATION OR EXCLUSION MAY NOT APPLY TO YOU.

THIS LIMITED WARRANTY GIVES YOU SPECIFIC LEGAL RIGHTS, AND YOU MAY ALSO HAVE OTHER RIGHTS WHICH VARY FROM STATE TO STATE IN THE U.S., PROVINCE TO PROVINCE IN CANADA AND FROM COUNTRY TO COUNTRY.

THIS LIMITED WARRANTY APPLIES ONLY TO PORTABLE ELECTRIC TOOLS, BENCH POWER TOOLS, OUTDOOR POWER EQUIPMENT AND PNEUMATIC TOOLS SOLD WITHIN THE UNITED STATES OF AMERICA, CANADA AND THE COMMONWEALTH OF PUERTO RICO. FOR WARRANTY COVERAGE WITHIN OTHER COUNTRIES, CONTACT WEN CUSTOMER SUPPORT.