



MERCER VI

72" x 36" Skirted Acrylic Air Bath

Model Number
 3672MASR-WH
 3672MASL-WH
 RH & LH Drain White Air Bath
 3672MASR-BI
 3672MASL-BI
 RH & LH Drain Biscuit Air Bath

Features

- 20+ high output lateral air jets
- 12 Amp variable speed blower
- Constructed of high-gloss durable acrylic
- Pre-leveled base for easy installation
- Automatic purge cycle with timer
- Maintenance water heater included
- Pillow included
- Made in the USA



All dimensions are +/- 1/2" and subject to change without notice
Confirm specifications before installation

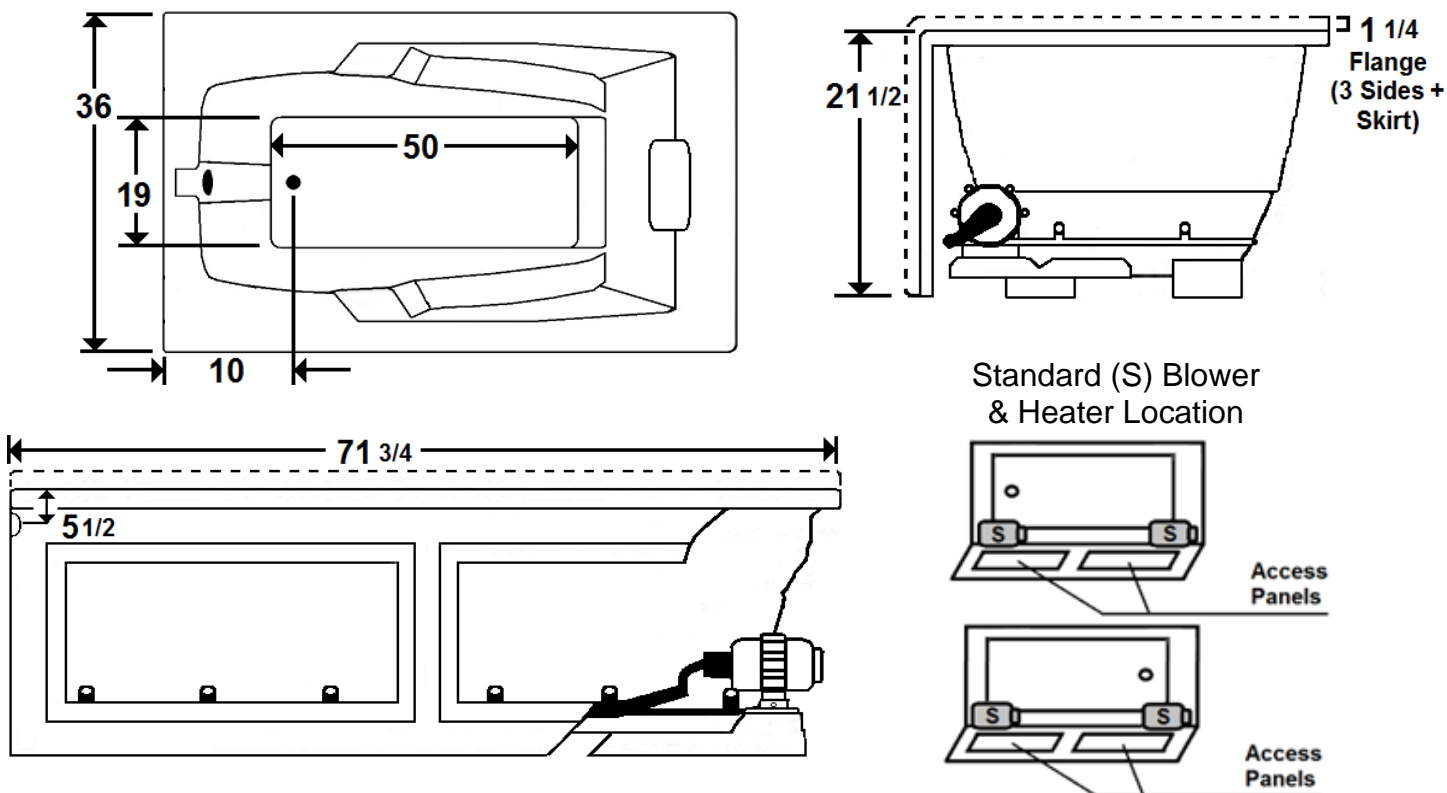

Technical Information

- Weight: 145 lbs.
- Water Depth to Overflow: 15 1/4"
- Water Operating Level: NA
- Water Capacity: 71 gal.
- Sump Dimension: 50" x 19"

Electrical Requirements.

- Standard Blower: 12 Amps
- Maintenance Heater: 12.5 Amps
- 2, 20 Amp Dedicated GFCI's required