

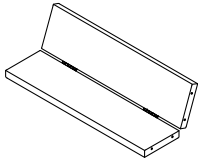

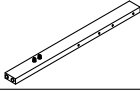

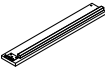
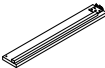

ASSEMBLY INSTRUCTIONS
Item No : WF281695
Description : BED STORAGE BENCH

Thank you for purchasing this quality product. Be sure to check all packing material carefully for small part that may have come loose inside the carton during shipment.



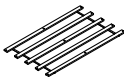
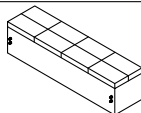



PART LIST :

No.	Description	Sketch	Quantity
A	Headboard		1PC
B	HB Posters L/R		2PCS
C	Side Rail Left		2PCS
D	Side Rail Right		2PCS
E	Support Side Rail		2PCS
F	Center Support Slats		2PCS
G	Slat Support Leg		6PCS
H	Slats Roll		2SET
J	Storage Body		1PC
K	Round Leg		4PCS

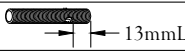
TOOLS REQUIRED (Not provided)



HARDWARE LIST :

No.	Description	Sketch	Size	Quantity
M	Bolt		Ø 5/16" * 2" L	8PCS
N	Thread Bolt		Ø 5/16" * 2" L	8PCS
O	Hexagonal Nut		Ø 5/16"	8PCS
P	Spring Washer		Ø 5/16"	16PCS
Q	Flat Washer		Ø 5/16"	16PCS
R	Open Wrench		M12	1PC
S	Allen Key		M4 * 2-1/2" L	1PC
T	Screw		Ø 8 * 1-1/4" L	20PCS

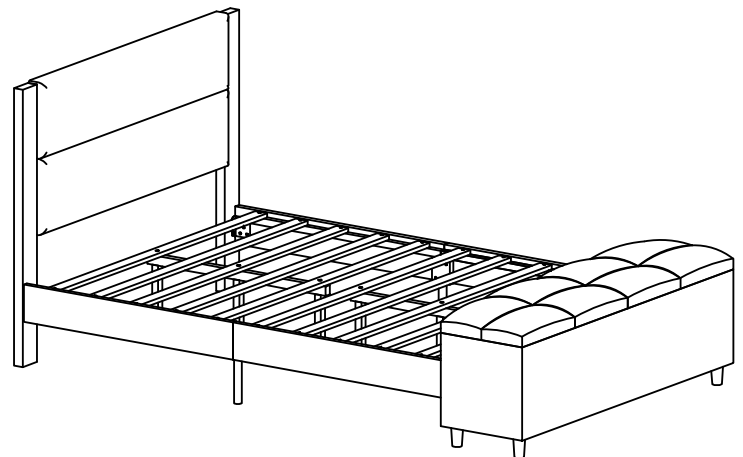

PLEASE DO NOT RETURN PRODUCT TO THE STORE.

If you have any problem or concerns, please feel free to contact our customer service department. Please send your request to the following contact details according to the platform you purchased.

ASSEMBLY INSTRUCTIONS





Item No : WF281695

Description : BED STORAGE BENCH

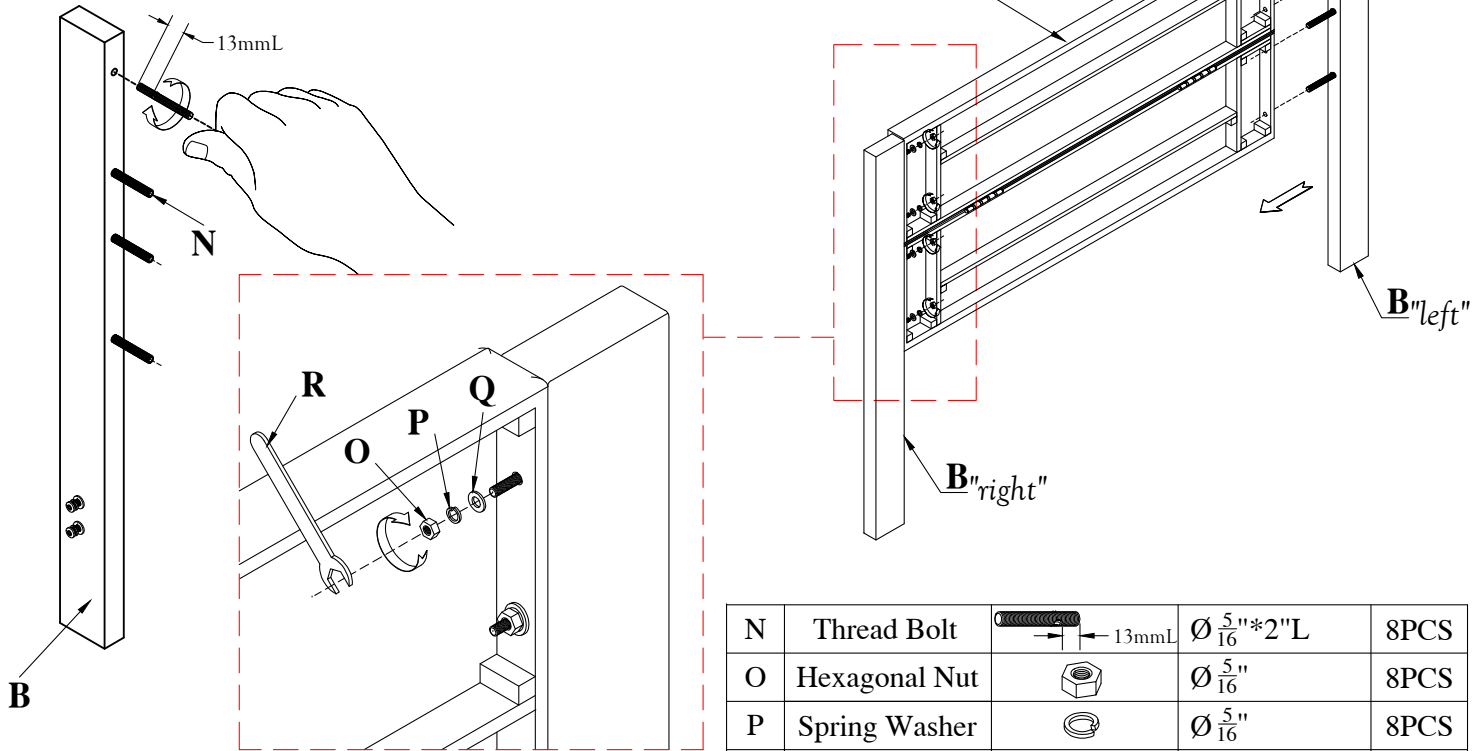
Thank you for purchasing this quality product. Be sure to check all packing material carefully for small part that may have come loose inside the cartons during shipment.

Step 1. Attach the Thread Bolt(N) to the HB Posters L/R(B) cushion, onto pre-drilled holes and secure by hand. Next locate the correct. Put the HB Posters L/R(B) cushion to the Headboard(A), by using the Flat Washer(Q), Spring Washer(P), Hex Nut(O) and Open Wrench(R).



N	Thread Bolt	 13mmL	$\text{Ø} \frac{5}{16} \text{''} * 2 \text{''} \text{L}$	8PCS
O	Hexagonal Nut		$\text{Ø} \frac{5}{16} \text{''}$	8PCS
P	Spring Washer		$\text{Ø} \frac{5}{16} \text{''}$	8PCS
Q	Flat Washer		$\text{Ø} \frac{5}{16} \text{''}$	8PCS
R	Open Wrench		M12	1PC

Step 2. Put both secure four Round legs(K) into pre-drilled holes on the bottom of the Storage Body(J). Please avoid overtightening.

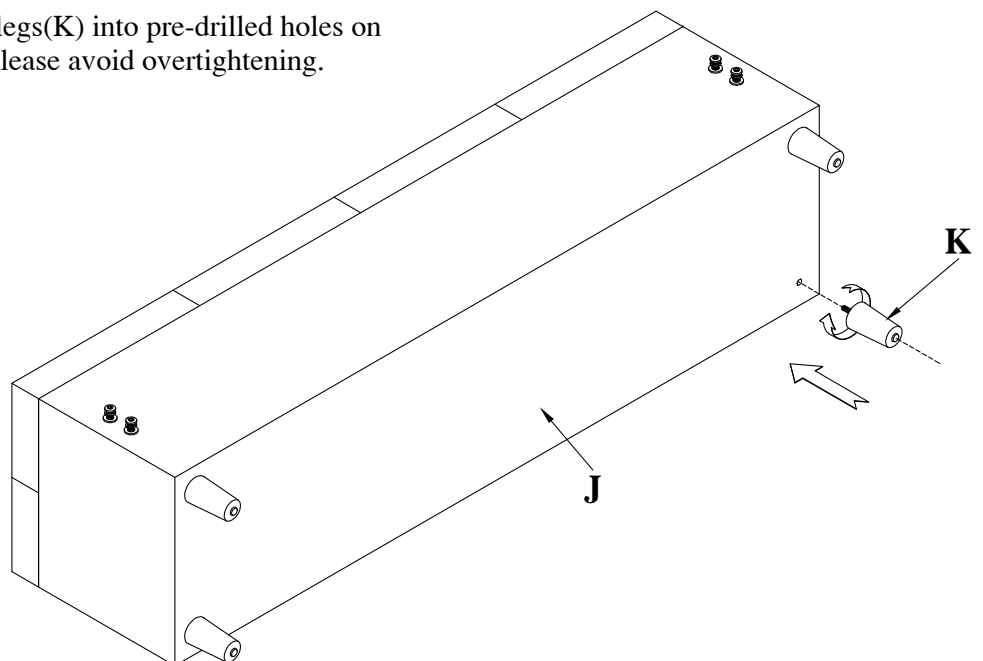



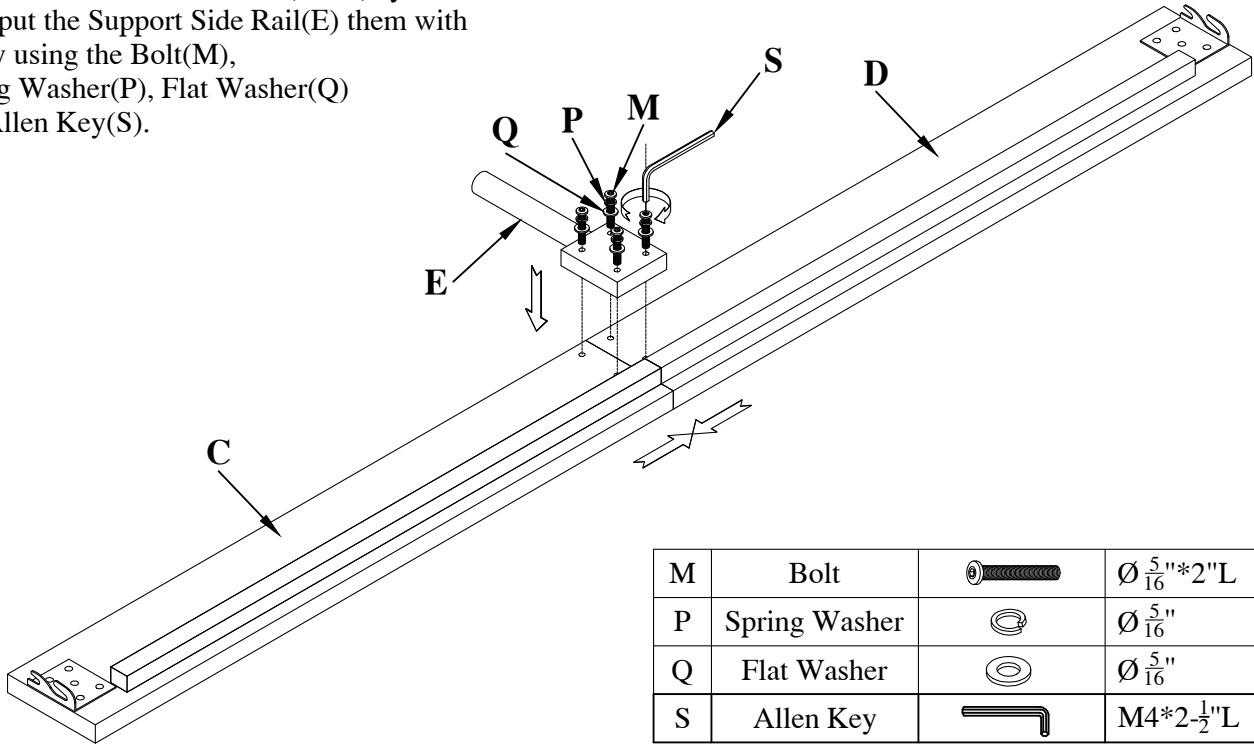

ASSEMBLY INSTRUCTIONS
Item No : WF281695
Description : BED STORAGE BENCH

Thank you for purchasing this quality product. Be sure to check all packing material carefully for small part that may have come loose inside the carton during shipment.

Step 3. Put the Side Rail L/R(C&D) symmetrical.
 Next put the Support Side Rail(E) them with the by using the Bolt(M), Spring Washer(P), Flat Washer(Q) and Allen Key(S).



M	Bolt		$\text{Ø} \frac{5}{16} \times 2''\text{L}$	8PCS
P	Spring Washer		$\text{Ø} \frac{5}{16}''$	8PCS
Q	Flat Washer		$\text{Ø} \frac{5}{16}''$	8PCS
S	Allen Key		$\text{M4} \times 2\frac{1}{2}''\text{L}$	1PC

Step 4. Before performing this step, please loosen the Bolts of the HB Posters L/R(B) cushion and Storage Body(J), intended to hook metal Rail L/R(C;D) is securely inserted into the bolts, then the tighten them with the Allen Key(S).

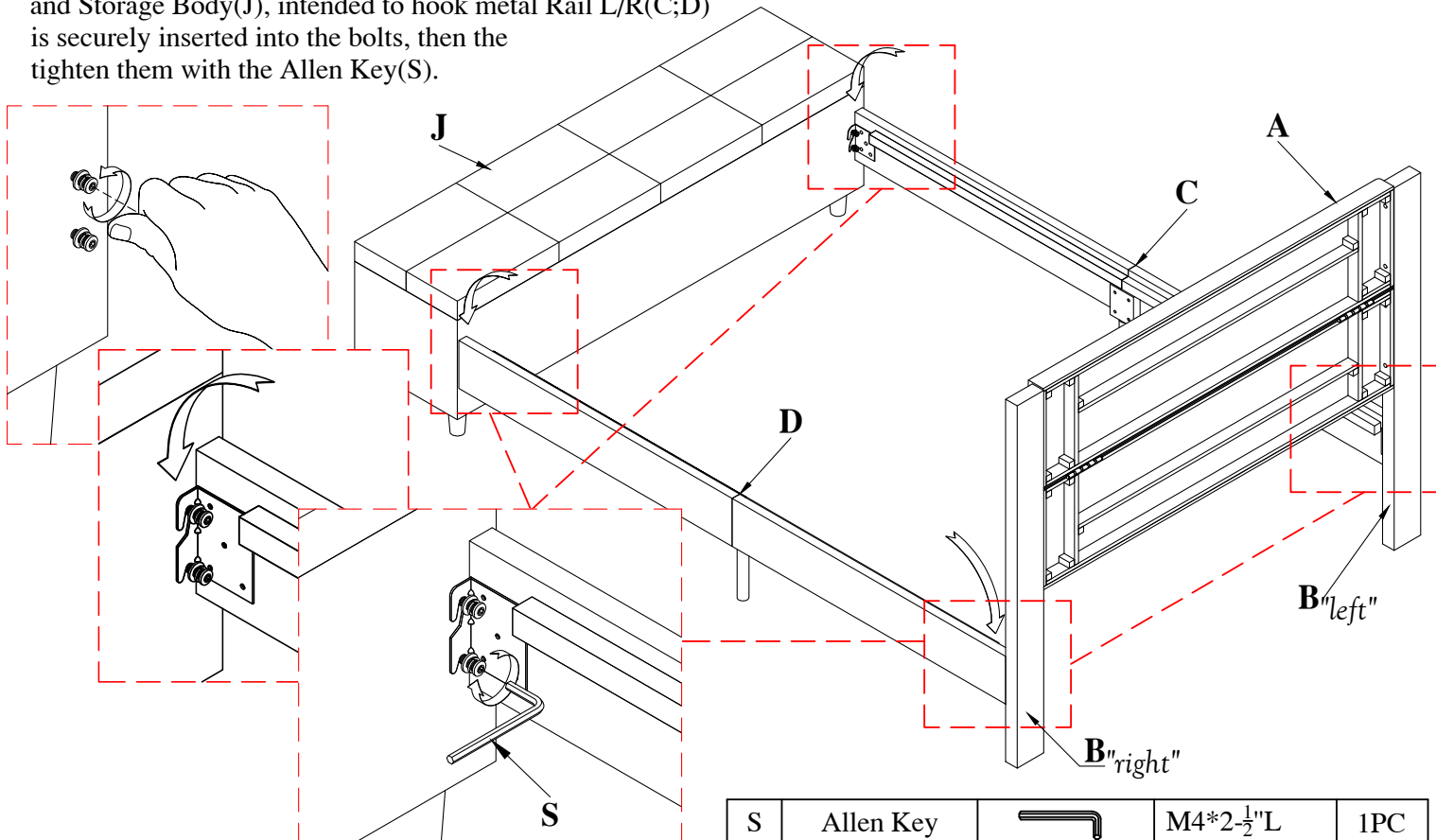

S	Allen Key		$\text{M4} \times 2\frac{1}{2}''\text{L}$	1PC
---	-----------	---	---	-----

ASSEMBLY INSTRUCTIONS
Item No : WF281695
Description : BED STORAGE BENCH

Thank you for purchasing this quality product. Be sure to check all packing material carefully for small part that may have come loose inside the carton during shipment.

Step 5. Set Slat roll(H), link pre-wire up. Next, Place the Center support(F), align the drill holes. At the same time, use the Support leg(G) to pass through the holes on the Center rail(F) one by one, to link through the Slat roll(H) and tighten them together.

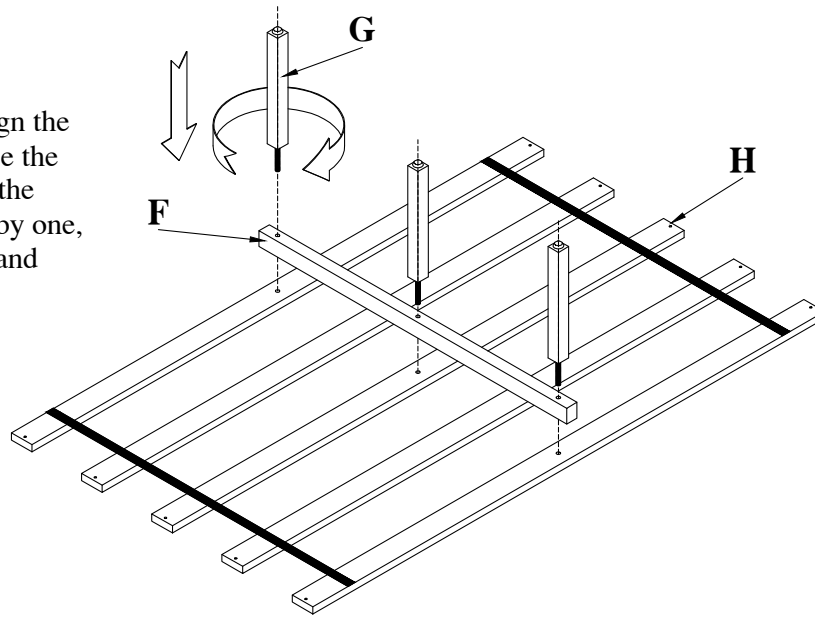

Step 6. Put the two Slat roll clusters on the side rails of the bed to be neat, then tighten they are by Screws(T).

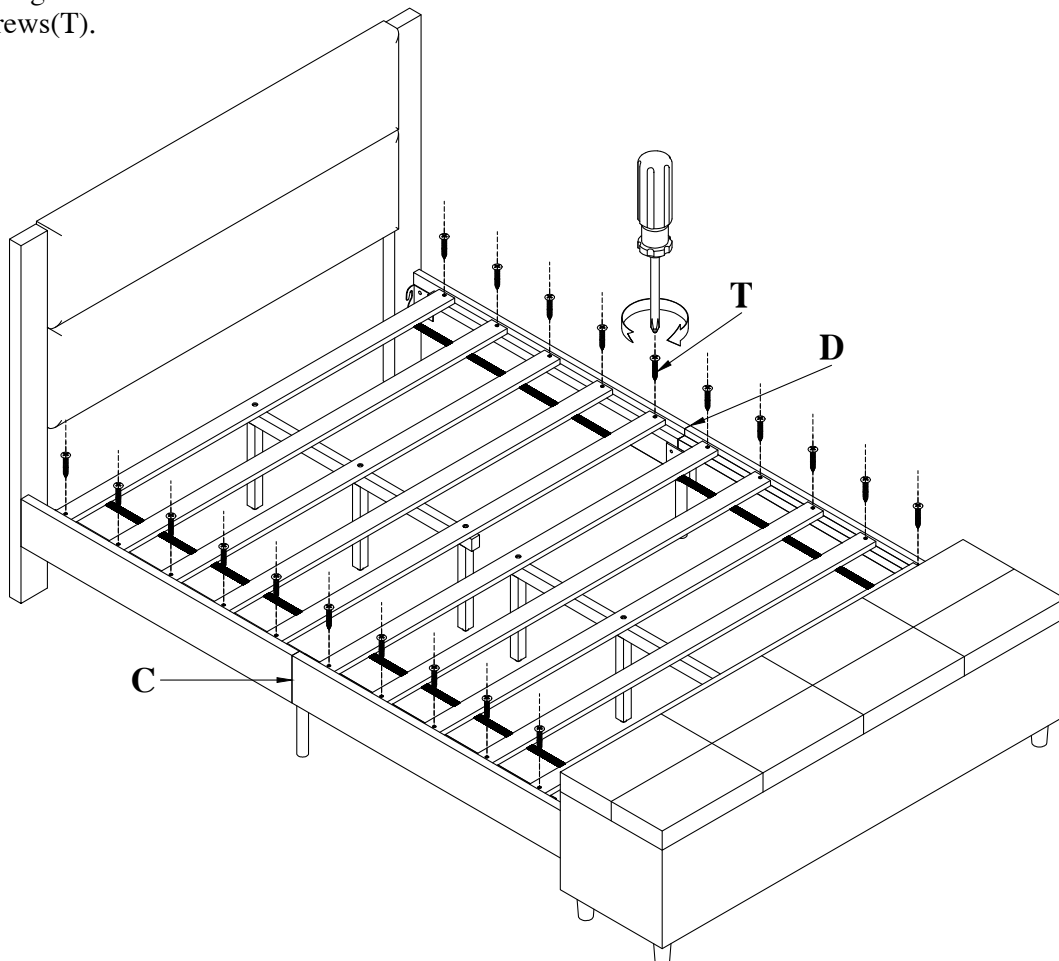

T	Screw		Ø8*1-¼"L	20PCS
---	-------	---	----------	-------