



















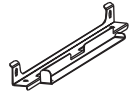
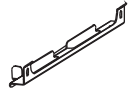











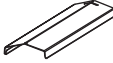

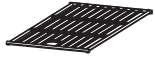





No.	#	QTY / CANT. / QTÉ	Description / Descripción / Description	Image / Imagen / Image
1	07-QPG-08-DD3 +AJQP GDZ01	1	LP cylinder screw Perno de fijación de la bombona Vis de bouteille de gaz	
2	05-WXL-27	4	Caster Rueda Roulette	
3	EJDB08H2B-A	1	Bottom shelf Estante inferior Etagere inferieure	
4	EJGDSJB01	2	Triangle support plate Placa de soporte triangular Plaque de support triangulaire	
5	EJHB022B	1	Rear panel Panel trasero Panneau arrière	
6	EJCB03	2	Side panel Panel lateral Panneau latéral	
7	EJQPGRB01-DS1 +EJQPGRBJQ P01-RGC	1	Thermal baffle Deflector térmico Panneau isolant	
8	04-GBS-2-02- 200-PG	1	Door handle Tirador de la puerta Poignée de la porte	
9	04-BSZ-03-BK	2	Handle sleeve Base de encastre del tirador Manche de poignée	
10	EJSM042B +EJSMNC042B -DS1	1	Cabinet door Puerta del armario Porte d'armoire	
11	EJLTGDBL02	1	Grease tray bracket (L) Fijación de Bandeja de recojida de grasa (I) Support du Lèchefrite (G)	
12	EJLTGDBR02	1	Grease tray bracket (R) Fijación de Bandeja de recojida de grasa (D) Support du Lèchefrite (D)	
13	ET47GDZJL	2	Side shelf bracket (L) Soporte de bandeja lateral (I) Support de étagère latérale (G)	
14	ET47GDZJR	2	Side shelf bracket (R) Soporte de bandeja lateral (D) Support de étagère latérale (D)	
15	EJHL04H2B-A +06-CTL-01	1	Cart beam Barra del carro Poutre du chariot	
16	EJMGDPR01	1	Beam connector (R) Unión de la barra (D) Articulation du corps principal (D)	
17	ELYB02-LS4	1	Grease cup Depósito de recogida de grasa Bac à graisse	
18	ELYBZJL02	1	Grease cup bracket (L) Fijación del depósito de recogida de grasa (I) Support du bac à graisse (G)	

No.	#	QTY / CANT. / QTÉ	Description / Descripción / Description	Image / Imagen / Image
19	ELYBZJR02	1	Grease cup bracket (R) Fijación del depósito de recojida de grasa(D) Support du bac à graisse (D)	
20	ELJYP012B-DS2	1	Grease tray Bandeja de recogida de grasa Lèchefrite	
21	ET47H +08-ZZL-07 +07-GGL-21-SI	2	Side shelf Bandeja lateral Étagère latérale	
22		1	Main body Cuerpo principal Corps principal	
23	06-WDJ-2-03- RGC+06-WDZ-04	1	Thermometer Termómetro Thermomètre	
24	ELFHB07	3	Flame tamer Regulador de llama Atténuateur de flamme	
25	ELBWW012B-SS4	1	Warming rack Rejilla para calentar Grille de réchauffement	
26	03-ZTW-E-01-TC4	2	Cooking grate Rejilla para asar Grille de cuisson	

No.	#	Image / Imagen / Image	No.	#	Image / Imagen / Image
A	M5-10	 x61	G	M5-10	 x4
B	Hooks Ganchos Crochets	 x6	H	M4-10	 x2
C	Stud with nut Espárrago con tuerca integrada Goujon avec écrou	 x2	I	Washer Arandela Rondelle	 x4
D	M5-10	 x10	J	M4-8	 x4
E	Magnet Imán Aimant	 x1	K	Washer Arandela Rondelle	 x1
F	M6-12	 x4			

TOOLS REQUIRED / HERRAMIENTAS REQUERIDAS / OUTILS REQUIS

Phillips screwdriver Destornillador phillips Tournevis phillips	Wrench Llave Clé		
---	------------------------	--	---

Before beginning assembly, make sure all parts are present. If any parts are missing or damaged, do not attempt to assemble the products. Contact customer service for replacement parts via telephone or email.

- Tools needed (not included): Phillips screwdriver and wrench
- Approximate assembly time: 40 minutes
- Note: 1. The right and left sides of the grill are designed as if you are facing the front of the grill.
2. Model shown for illustration purpose only, specific please in kind prevail.

Antes de comenzar el montaje, asegúrese de que todas las piezas estén presentes. Si falta alguna pieza o está dañada, no intente ensamblar los productos. Póngase en contacto con el servicio de atención al cliente para obtener piezas de repuesto por teléfono o correo electrónico.

- Herramienta necesaria (no incluido): Destornillador phillips y llave
- Tiempo aproximado de ensamblaje: 40 minutos
- Nota: 1. Los lados derecho e izquierdo de la parrilla están diseñados como si estuvieras frente a la parte delantera de la parrilla.
2. El modelo que se muestra es sólo para fines ilustrativos, prevalecen los específicos en especie.



Avant de commencer l'assemblage, assurez-vous que toutes les pièces sont présentes. Si des pièces sont manquantes ou endommagées, n'essayez pas d'assembler les produits. Contactez le service de clientèle pour les pièces de rechange par téléphone ou par e-mail.

- Outils nécessaires (non inclus): Tournevis phillips et clé
- Temps nécessaire pour l'assemblage: 40 minutes
- Remarque: 1. Les côtés droit et gauche du gril sont conçus comme si vous faisiez face à l'avant du gril.
2. Le modèle est présenté à des fins d'illustration uniquement, spécifiques en nature prévalent.

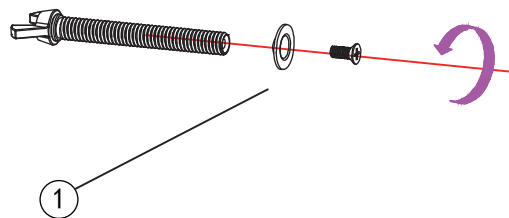
1



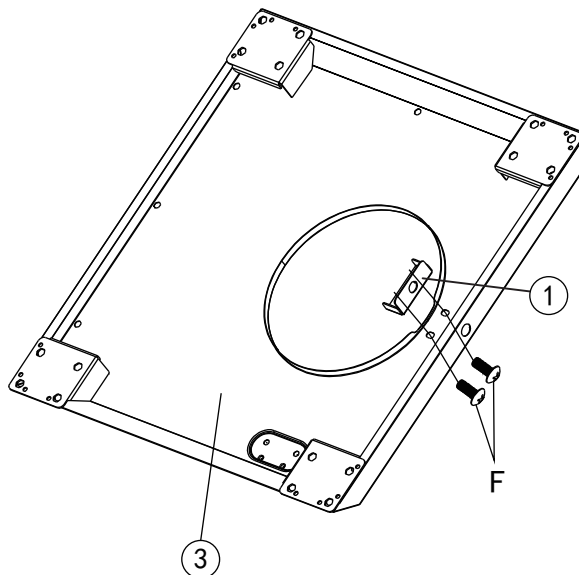

- Use the pre-installed screws from the LP cylinder screw.
- Utilice los tornillos preinstalados del tornillo del cilindro GLP.
- Utilisez les vis pré-installées de la bonbonne de gaz LP.

2 F   x2

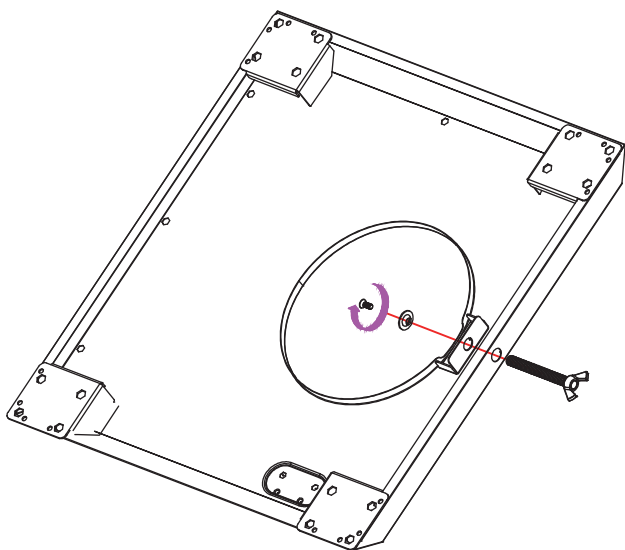

3



4 A   x16

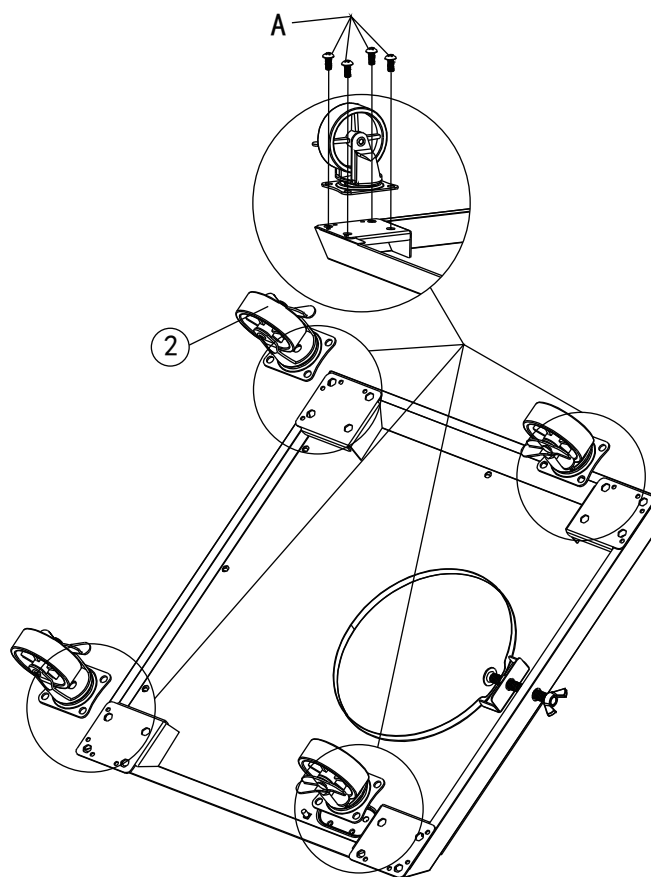

5 A  ×4

- Do not secure the bolts until step 7.
- No apretar las tornillos hasta el paso 7.
- Ne pas fixez les boulons avant l'étape 7.

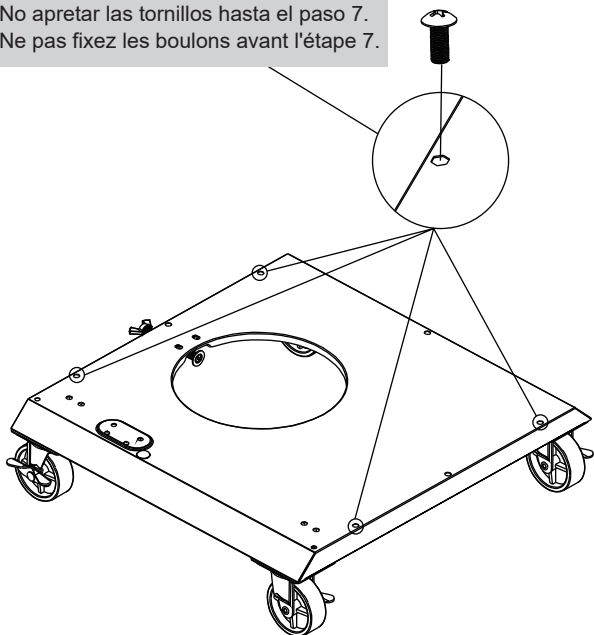

6

- Snap
- Encajar
- Enclenche

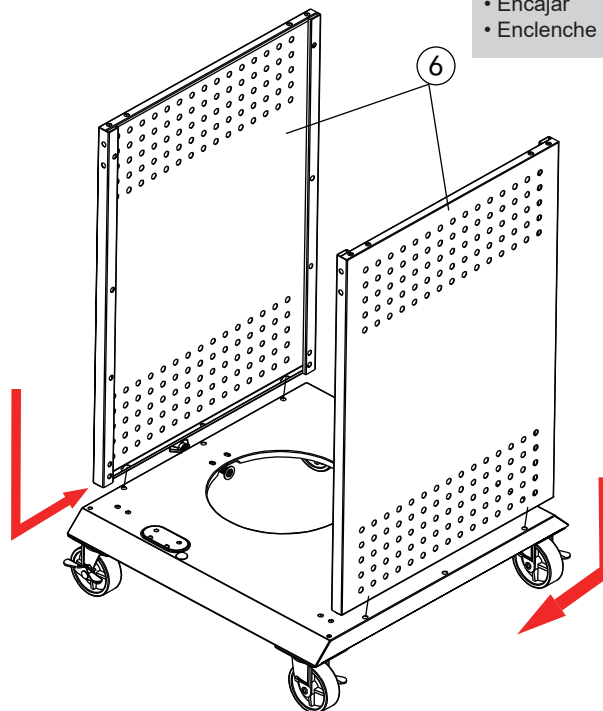

7 A  ×2

- Tighten
- Apretar
- Serre

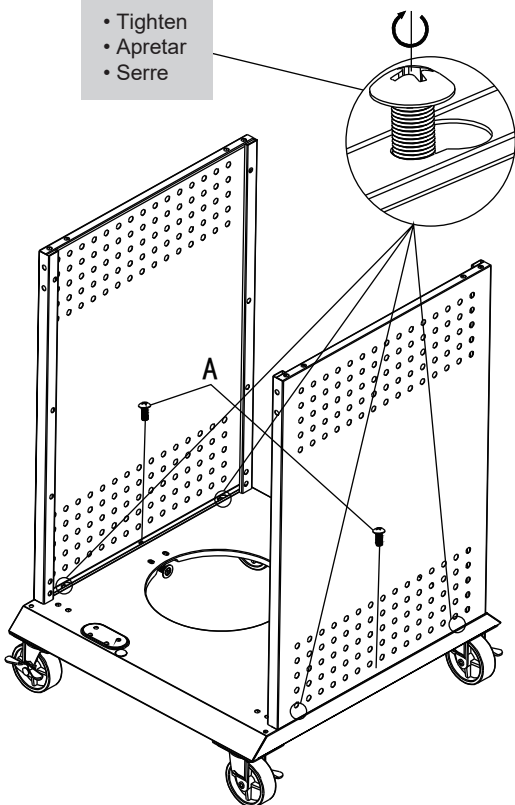

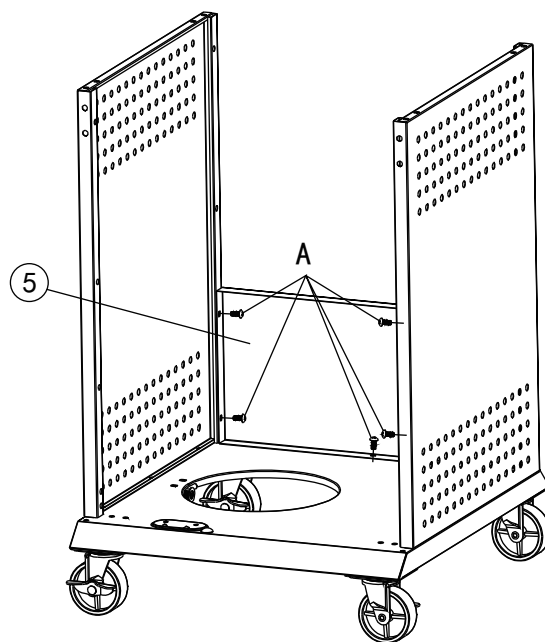

8 A  ×5

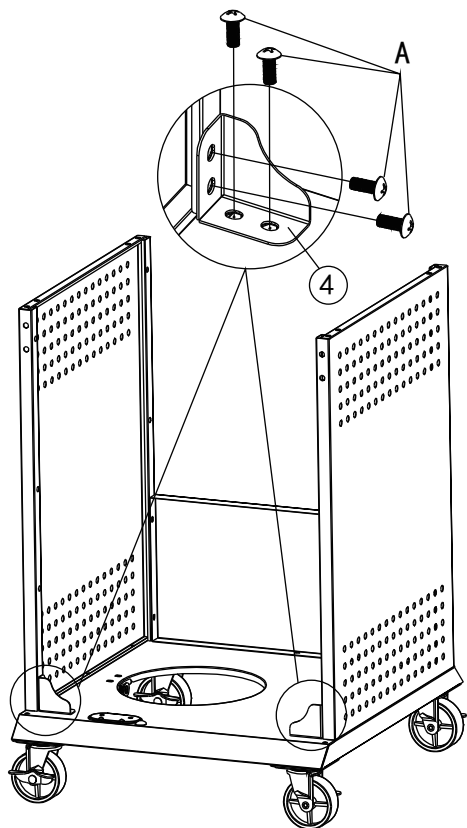

9 A  x8



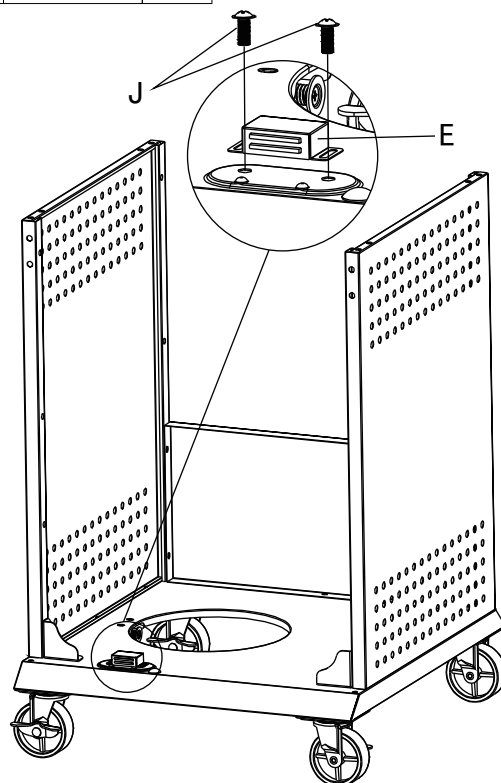

10 E  x1
J  x2

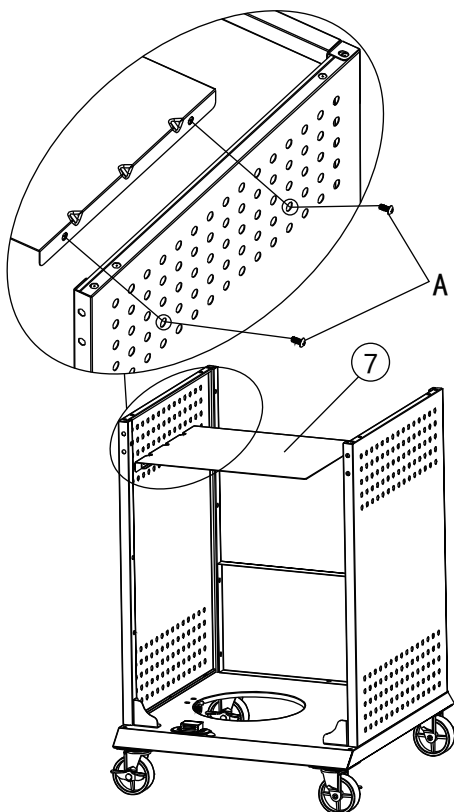

11 A  x2



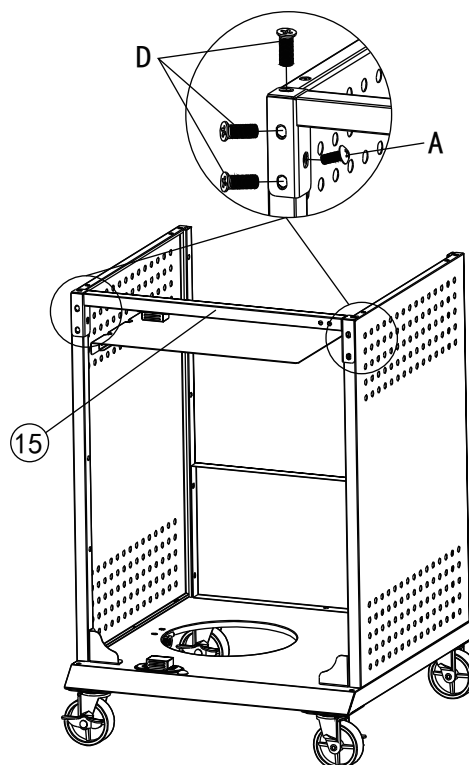

12 D  x6
A  x2

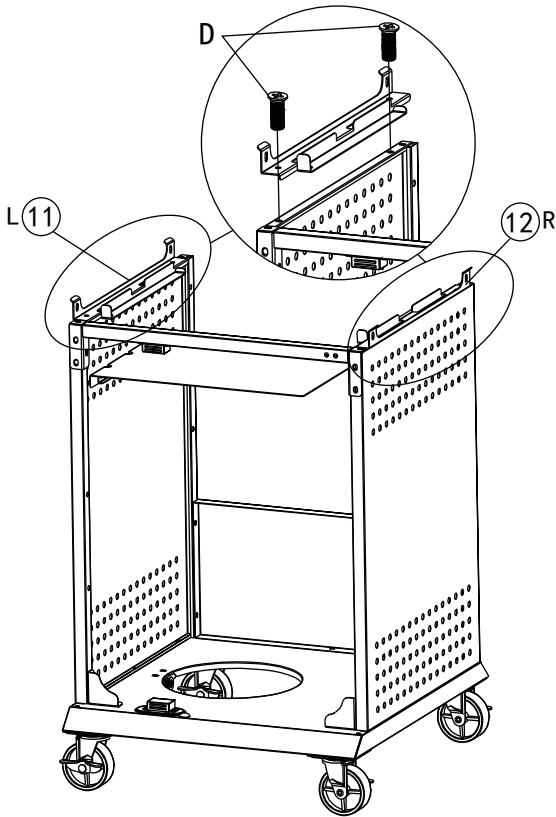

13 D  ⊕ ×4



14 I  ×2 C  ×2
F  ⊕ ×2

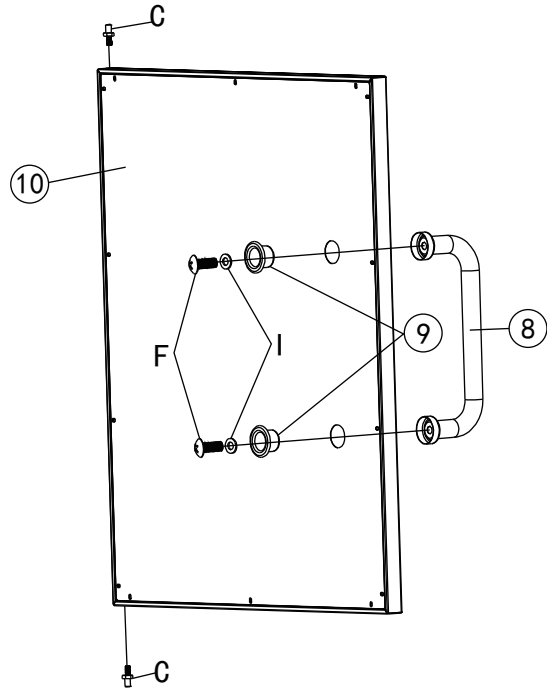

15 H  ⊕ ×2

3RD

- Tighten
- Apretar
- Serre

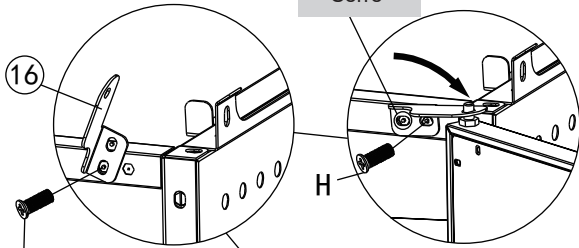

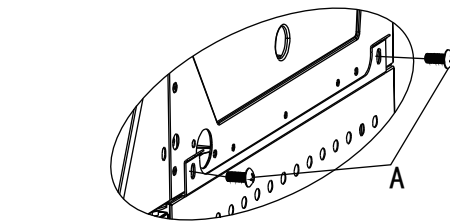

16 A  ⊕ ×4

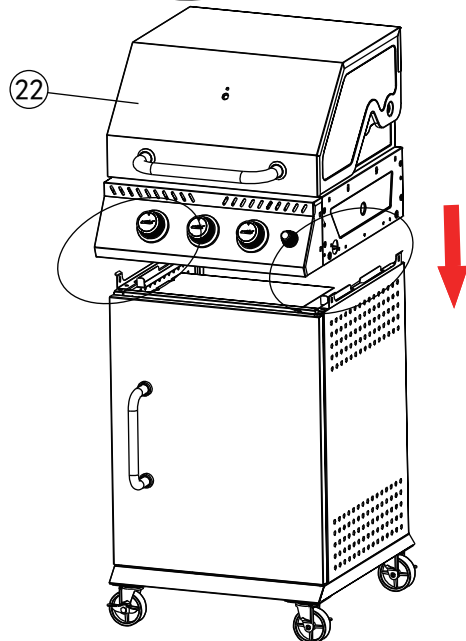
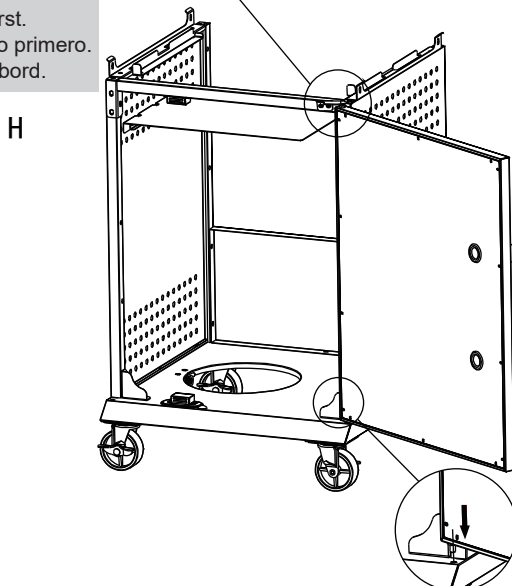

1ST

- Half screw first.
- Medio tornillo primero.
- Demi-vis d'abord.



17	B		×6
	A		×6

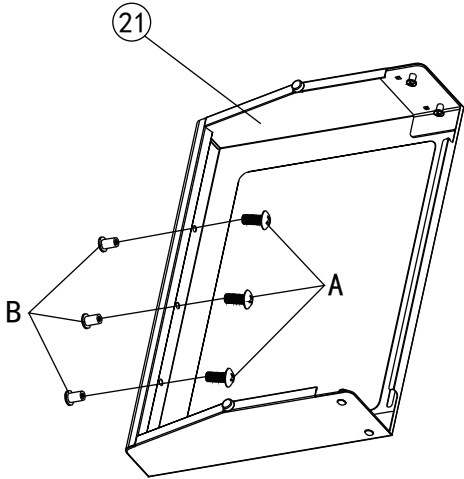

- Repeat for the other side.
- Repita esto paso para el otro lado.
- Répéter le étape pour l'autre côté.

18	A		×4
-----------	---	--	----

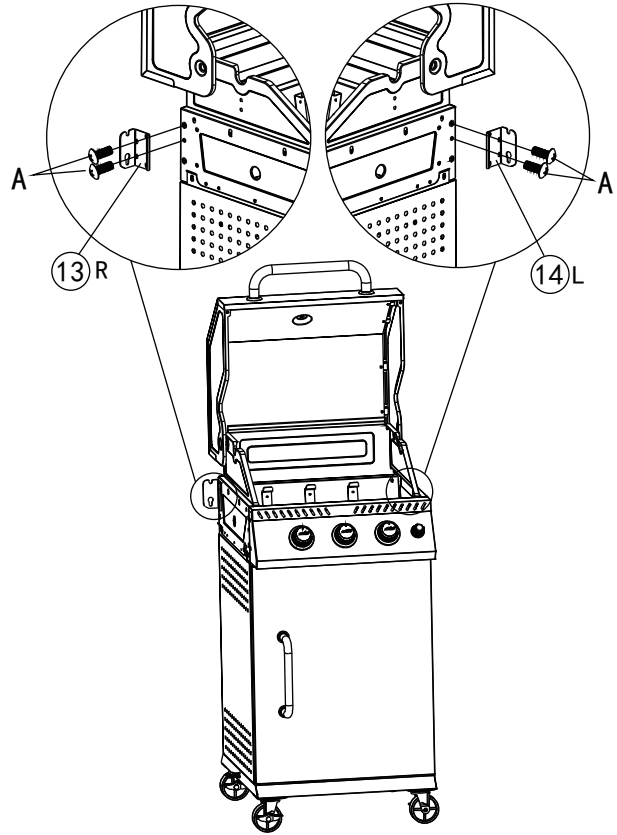

19	A		×4
-----------	---	---	----

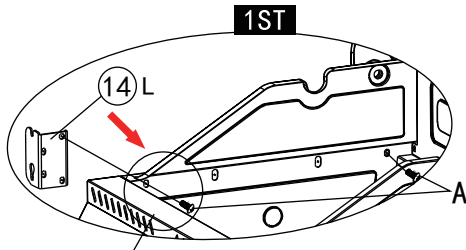

- Half screw first.
- Medio tornillo primero.
- Demi-vis d'abord.

- Attach it to the side shelf.
- Y ppr último, fijarlo a la estantería lateral.
- Fixez à l'étagère latérale.

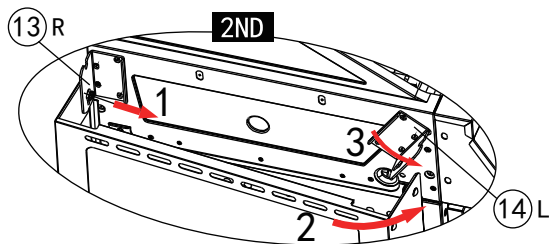

- Rotate to lock onto the side shelf.
- Girarlo hasta que encaje en la estantería lateral.
- Tournez pour verrouiller sur l'étagère latérale.

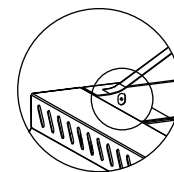
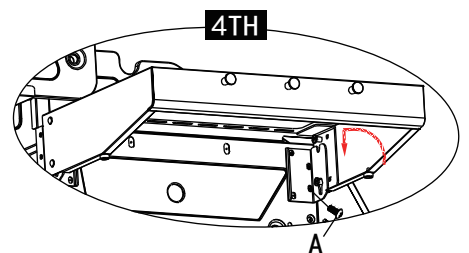
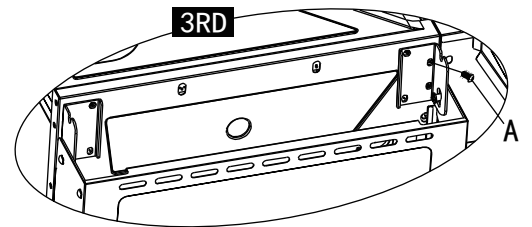

- Tighten
- Apretar
- Serre

20 A  ⊕ ×4

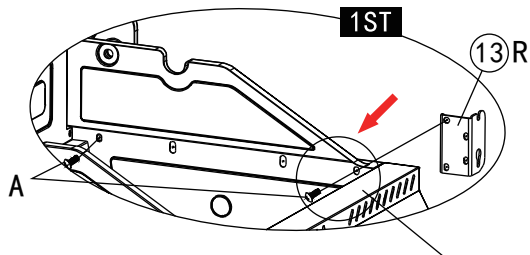

- Half screw first.
- Medio tornillo primero.
- Demi-vis d'abord.

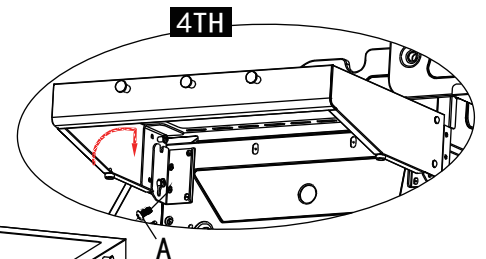
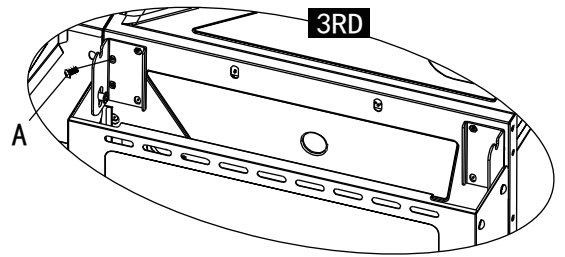

- Rotate to lock onto the side shelf.
- Girarlo hasta que encaje en la estantería lateral.
- Tournez pour verrouiller sur l'étagère latérale.

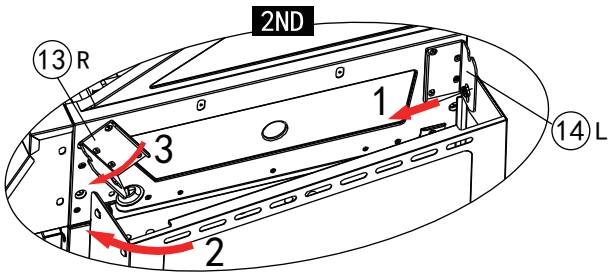

- Attach it to the side shelf.
- Y ppr último, fijarlo a la estantería lateral.
- Fixez à l'étagère latérale.

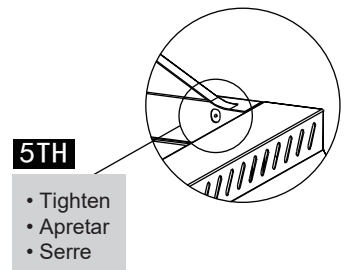
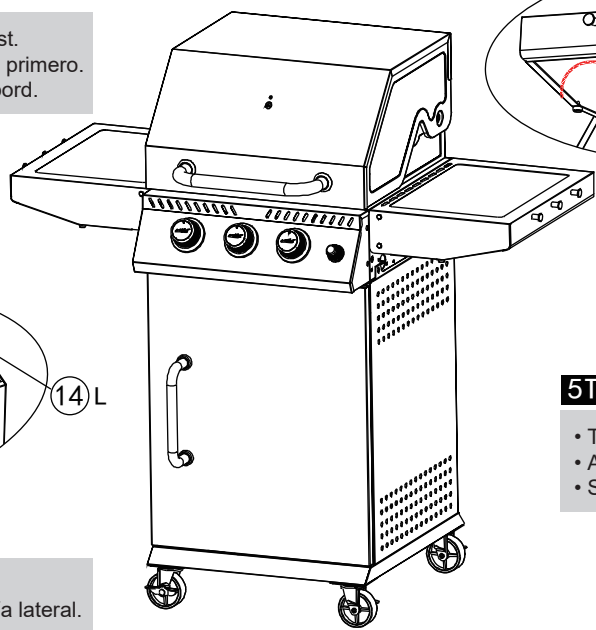

- Tighten
- Apretar
- Serre

21 G  ⊕ ×4

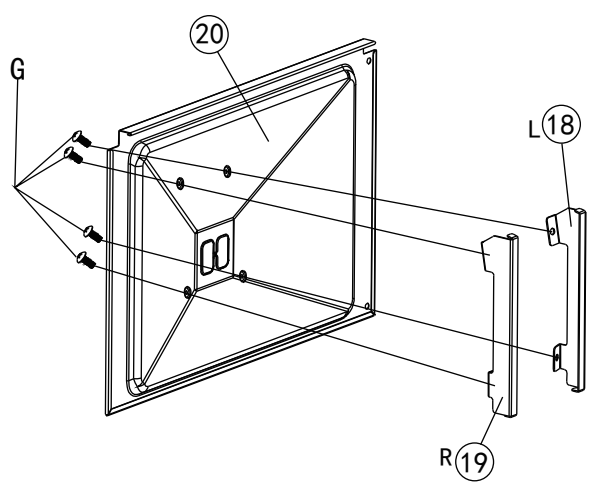

22

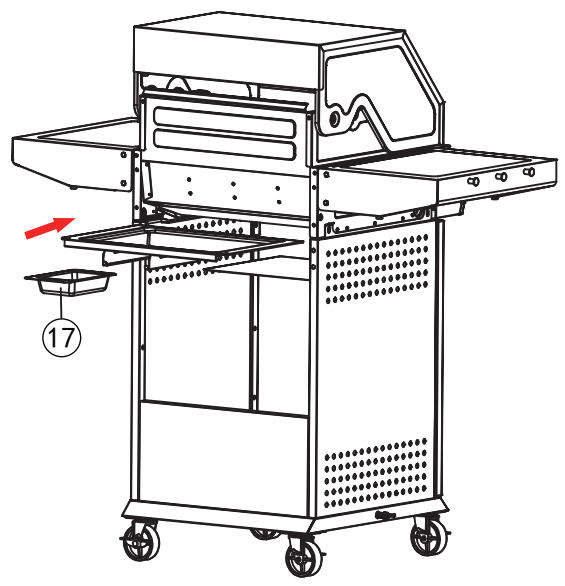

23 K  x1

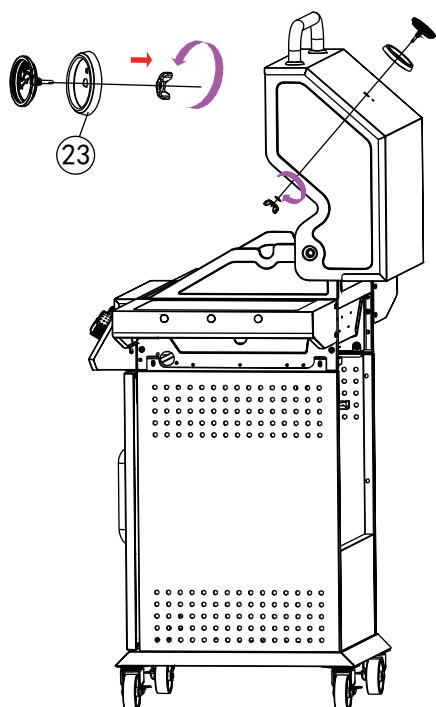

24

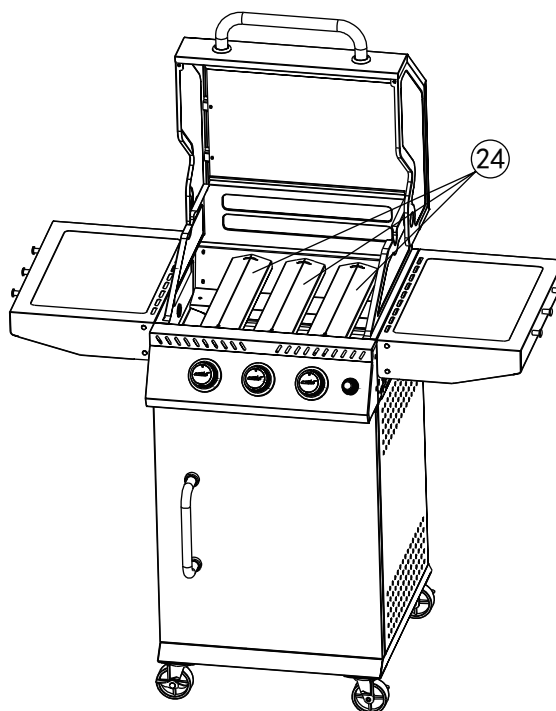

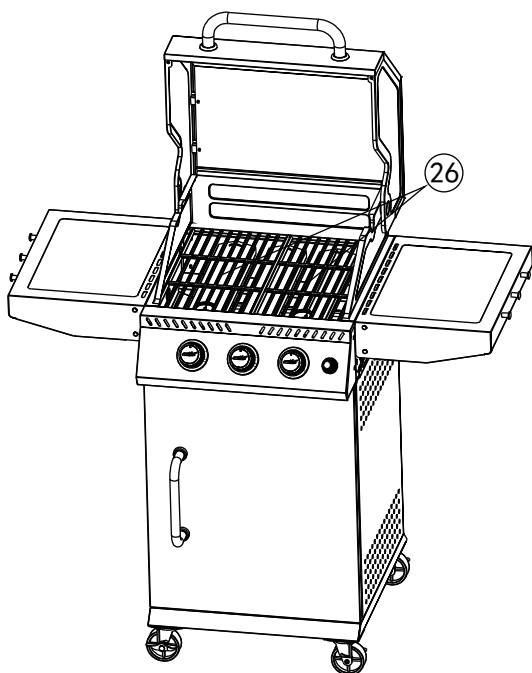

25

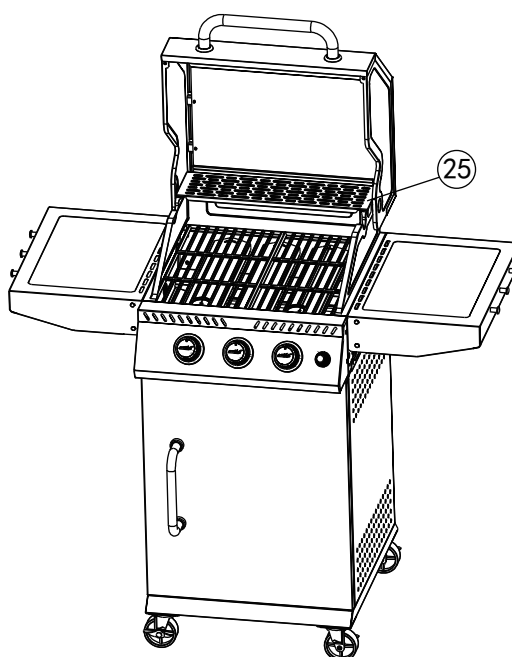

26

- Remove protective film from stainless steel warming rack before using.
- Retire la película protectora de la rejilla para calentarde acero inoxidable antes de usar.
- Retirez le film protecteur de la grille de réchauffement en acier inoxydable avant utilisation.



27	I		x2
	J		x2

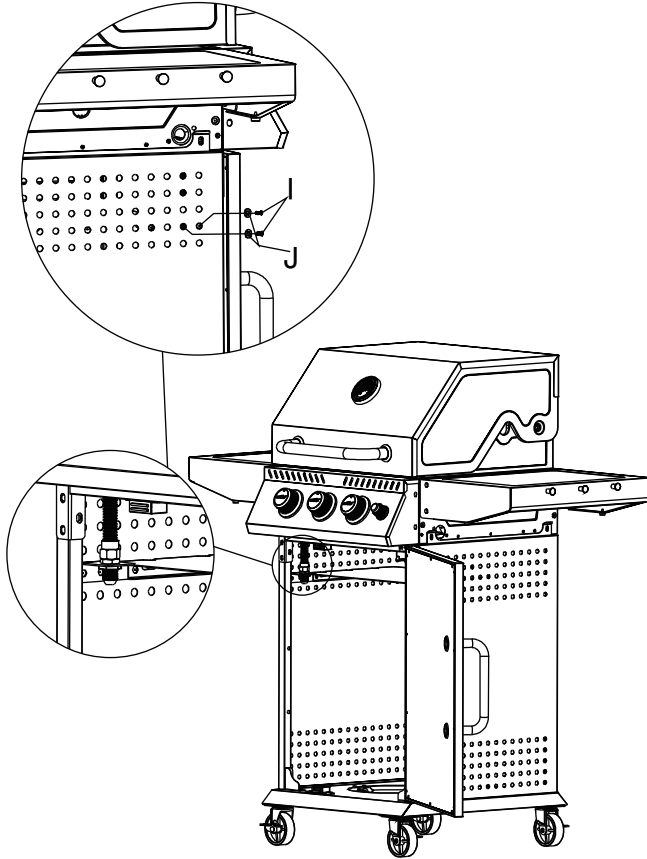

**Thank You
For Choosing Us.**

**Any Problem!
We Can Help!**

**Customer
Service**

1-800-618-6798

Monday to Friday (8:30 am - 5:00 pm EST)

service@royalgourmetusa.com