

Exposed Shower Faucet Installation Manual

W-321(ES)

Warranty Duration

All components of this faucet system are covered under a lifetime limited warranty, ensuring they are free from defects in material and workmanship for the original purchaser.

Repair and Replacement

If the product shows defects in material or workmanship under normal use and within the warranty period, we will, at our discretion, either repair the product or provide a replacement at no cost to the original purchaser. Please note that proof of purchase (e.g., an invoice) is required when requesting service. The warranty does not cover damages caused by improper installation, misuse, or modifications.

Exclusions

We shall not be responsible for the following cases:

- Damage to the product caused by improper installation, misuse, unauthorized repair or replacement, or abuse (including damage during shipment).
- Damage to the product caused by improper dismantling after installation.
- Damage resulting from abnormal water pressure or impurities in water pipes, which is not covered under this warranty.
- Rust on the product due to insufficient care and maintenance, which is not covered under this warranty.
- Damage caused by natural disasters such as fire, flood, earthquake, lightning storms, etc., which is not covered under this warranty.

I hope this helps! If you have any further questions or concerns, please let me know.

Having Trouble? Contact us.

 Email: info@faucetsupport.com

 Toll Free: 1-888-969-6880



M7218
SFS-1329R

CONTENT

Pressure Balance Shower Faucet Installation Manual ----- (1-5)

CONTENIDO

**Manual de Instalación del Grifo de Ducha con Equilibrio de Presión
----- (6-10)**

◆ Installation and Maintenance Instructions

1. Check the accessories list to verify that all parts are complete in this package.
2. Do not disassemble the main body by yourself.
3. Connect inlet pipes to supply valves.
4. Make sure inlet pipes and supply valves have no impurities and are cleaned, with no impurities in the pipeline.
5. After installation, check all joints for leakages.
6. Do not leave the shower faucet exposed to a severely corrosive

Do's

1. In order to keep the mixer surface bright, please clean the mixer regularly.
2. Rinse the faucet with clean water and wipe it with a soft cotton cloth.
3. Use one of the following cleaners to remove dirt from the surface:
 - a. Mild liquid cleaner.
 - b. Colorless glass cleaner and powder cleaner that do not cause abrasion and can be dissolved completely.
 - c. Polish liquid that does not cause abrasion.

Don'ts

1. Avoid using cleaning powder, harsh cleaning chemicals, brushes and coarse cloth to prevent scratching and friction.
2. Do not use acid cleaners to clean the faucet as they may cause surface corrosion of the faucet. If the faucet is exposed to harmful acid substances, please rinse it immediately with water.

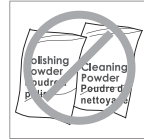
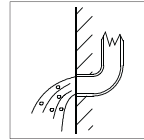
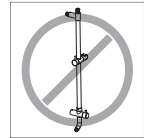

Tools Needed:

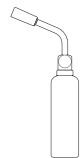
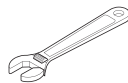
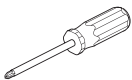

◆ **2-Function Rain Shower Faucet Accessories List**

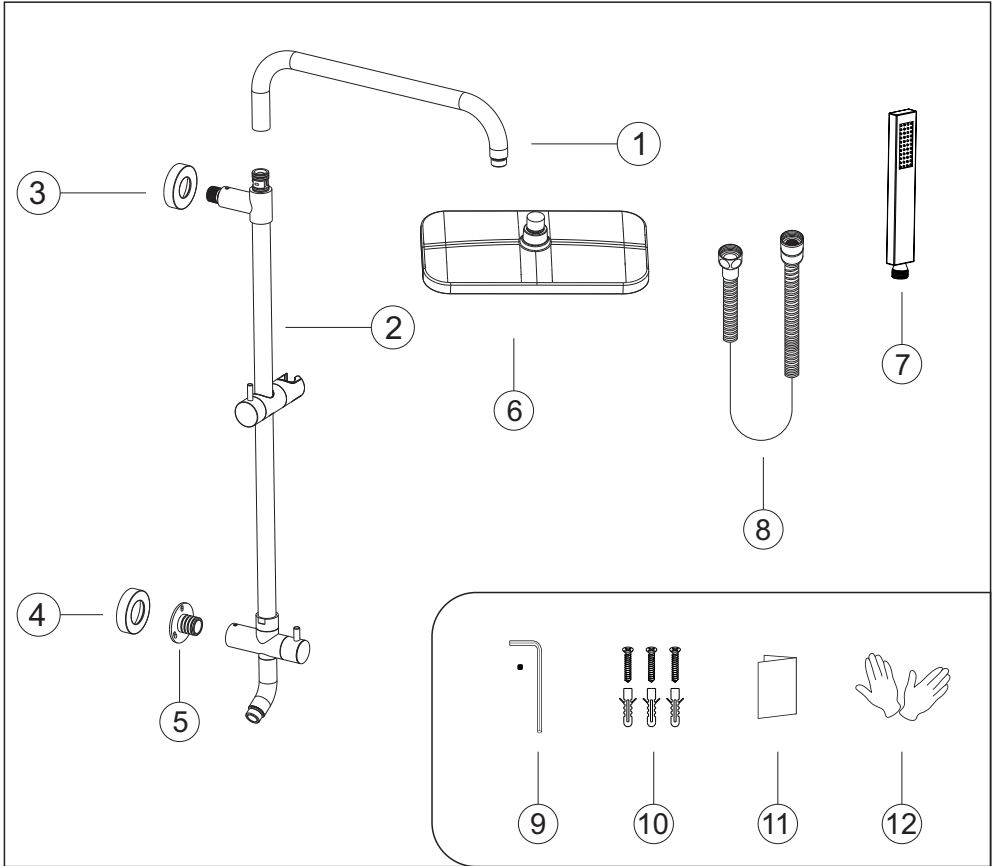

No.	Part Name	Qty	No.	Part Name	Qty
1	Shower Rod Elbow	1	7	Hand Shower	1
2	Shower Rod	1	8	Shower Hose	1
3	Inlet Decorative Cover	1	9	Shower Rod Elbow Parts	1set
4	Connector Decorative Cover	1	10	Fixed Joint Parts	1set
5	Fixed Joint	1	11	Instruction Manual	1
6	Shower Head	1	12	Gloves	2

◆ Essential Dimensions & Water Pipe Lines

Unit: mm/inch

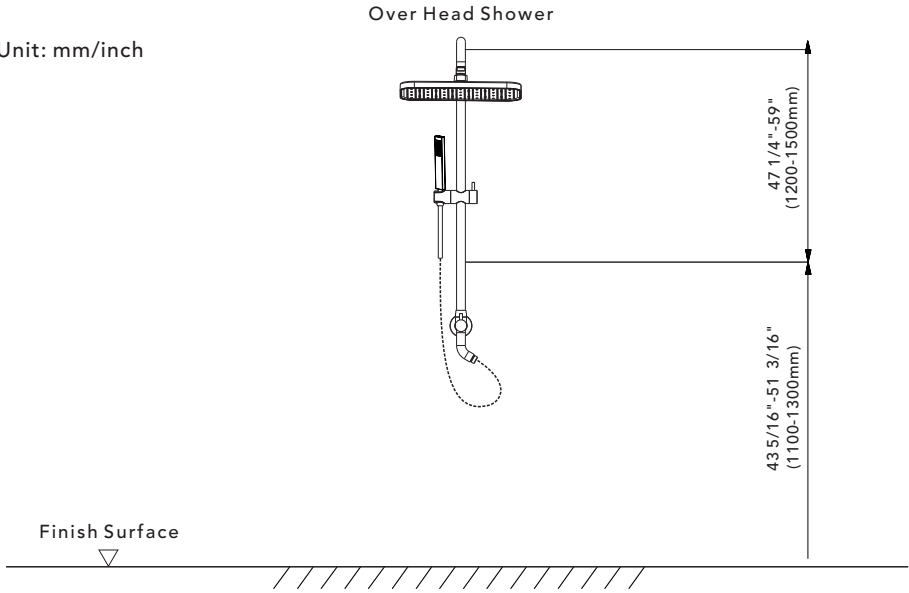

◆ Installation Depth of the Shower bar

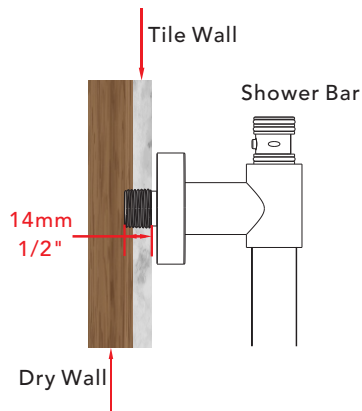

The thickness of the tile must be calculated for installation.

Connector size of male thread: USA: 1/2"-14NPT, Canada: 1/2"-14NPT, Europe: G1/2".

◆ Shower Rod Installation

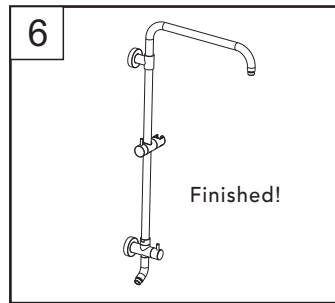
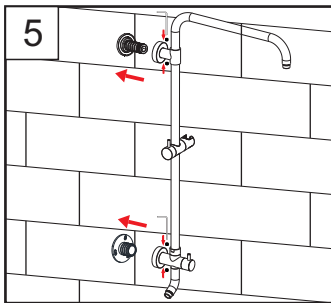
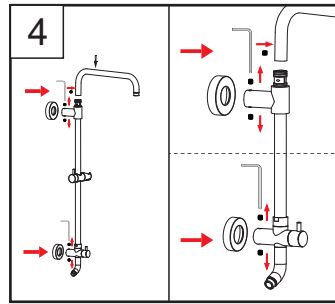
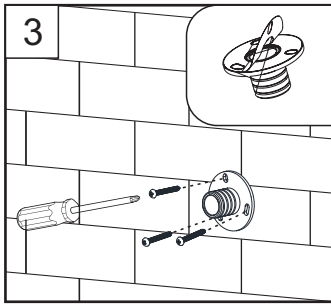
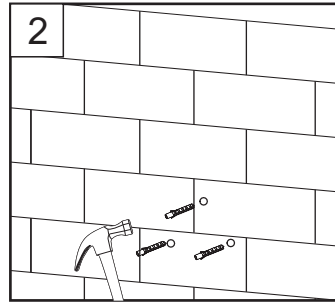
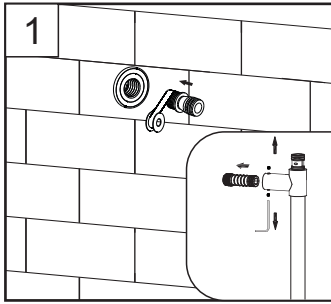

1. Drill a round hole in the wall that fits the size of the connector. Loosen the screws on the shower rod's fixed connector, remove the connector, and install it into the round hole.
2. Mark the positions of the three holes for the lower fixed connector of the shower rod on the wall. After drilling the holes, insert expansion screws.
3. Peel off the 3M adhesive on the connector and secure it to the wall with screws.
4. Attach the top curved pipe to the shower rod and tighten the screws. At the same time, remove the four screws from the shower rod connector and insert the decorative cap into the shower rod, as shown in Figure 4.
5. Insert the shower rod into the two installed connectors, then re-tighten the four screws.
6. Complete the installation of the shower rod.

◆ **Connect the Shower Rod, Hand Shower, and Overhead Shower**

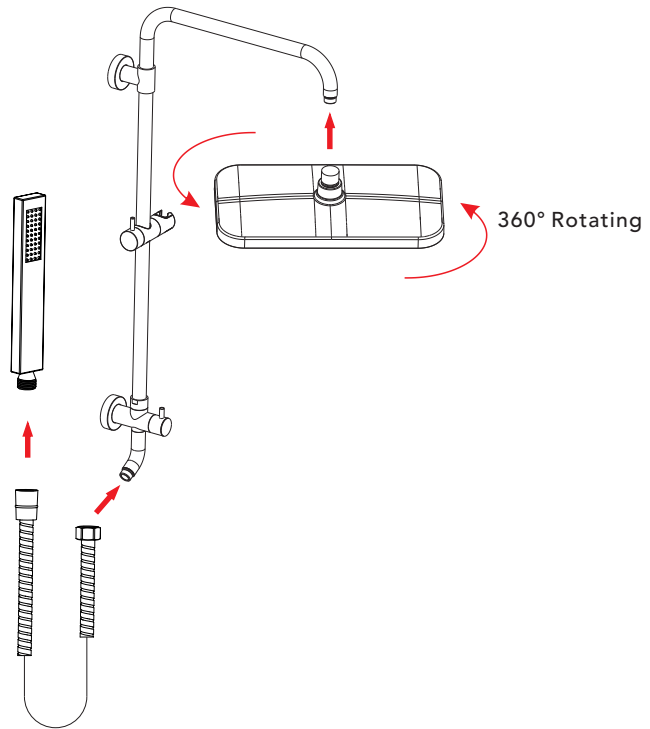

1. Tighten the connector for the shower hose and the connector for the overhead shower in the direction shown in the diagram to complete the installation.
2. The overhead shower head features 360° rotation.

◆ Instalación y Cuestiones de Mantenimiento

1. Compruebe la lista de accesorios para verificar que todas las piezas están completas en este paquete.
2. No desmonte el cuerpo principal por su cuenta.
3. Conecte las tuberías de entrada a las válvulas de suministro.
4. Asegúrese de que las tuberías de entrada y las válvulas de suministro no tengan impurezas y estén limpias, y de que no haya impurezas en la tubería.
5. Después de la instalación, compruebe que todas las uniones no presenten fugas.
6. No deje el grifo de ducha expuesto a un entorno fuertemente corrosivo.

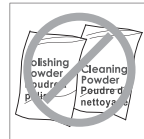
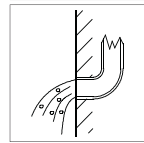
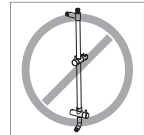

Qué Sí Hacer

1. Para mantener brillante la superficie del grifo, límpielo regularmente.
2. Enjuague el grifo con agua limpia y séquelo con un paño de algodón suave.
3. Utilice uno de los siguientes limpiadores para eliminar la suciedad de la superficie:
 - a. Limpiador líquido suave.
 - b. Limpiador de vidrio incoloro y limpiador en polvo que no causen abrasión y se disuelvan completamente.
 - c. Líquido de pulido que no cause abrasión.

Qué No Hacer

1. Evite el uso de polvos de limpieza, productos químicos de limpieza agresivos, cepillos y trapos ásperos para evitar arañazos y rozaduras.
2. No utilice limpiadores ácidos para limpiar el grifo, ya que pueden causar corrosión en la superficie. Si el grifo entra en contacto con sustancias ácidas dañinas, enjuáguelo inmediatamente con agua.

Herramientas Necesarias:

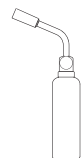
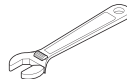
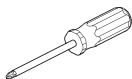

◆ **Grifo de Ducha de Lluvia de 2 Funciones**
Lista de Accesorios

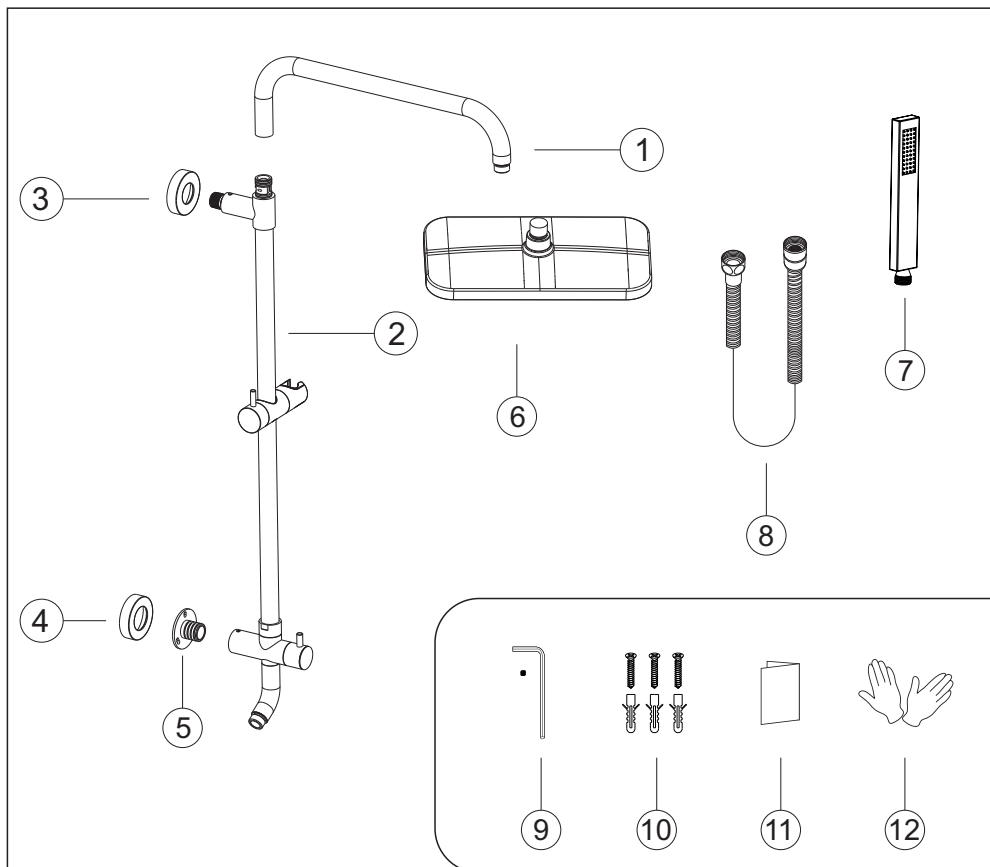

N.º	Nom de la pièce	Cantidad	N.º	Nom de la pièce	Cantidad
1	Codo de barra de ducha	1	7	Ducha de mano	1
2	Barra de ducha	1	8	Manguera de ducha	1
3	Tapa decorativa de entrada	1	9	Piezas del codo de barra de ducha	1 juego
4	Tapa decorativa del conector	1	10	Piezas de la junta fija	1 juego
5	Junta fija	1	11	Manual de instrucciones	1
6	Cabezal de ducha	1	12	Guantes	2

◆ Dimensiones Clave y Distribución de Tuberías de Agua

Unidad: mm/pulgada

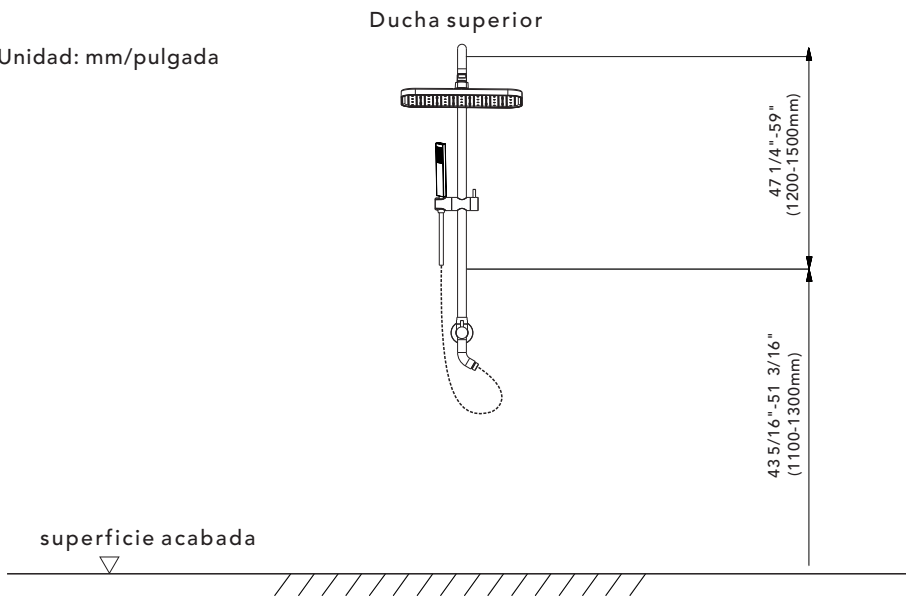

◆ Profundidad de Instalación de la Barra de Ducha

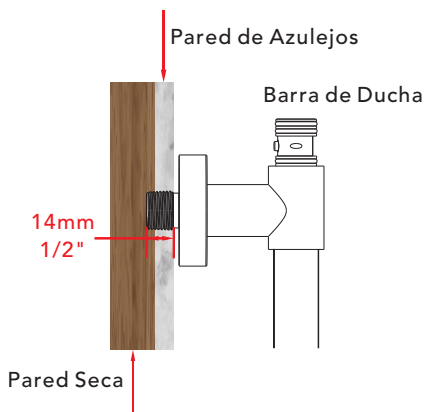

Debe calcularse el grosor del azulejo para la instalación.

Tamaño del conector de rosca macho: Mercado EE.UU.: 1/2"-14NPT, Mercado Canadá: 1/2"-14NPT, Mercado Europa: G1/2".

◆ Instalación de la Barra de Ducha

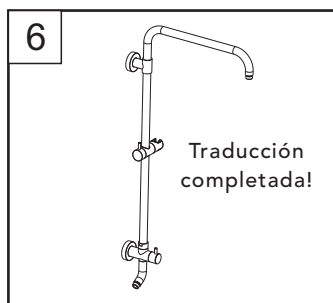
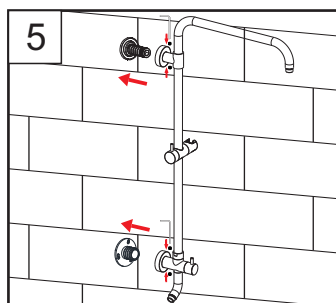
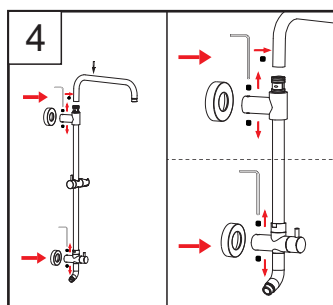
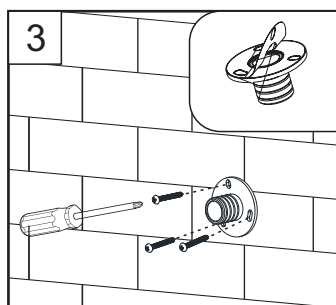
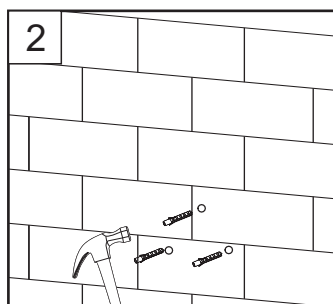
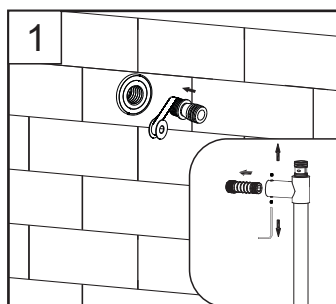

1. Perfore un agujero redondo en la pared que se ajuste al tamaño del conector. Afloje los tornillos del conector fijo de la barra de ducha, retire el conector e instálelo en el agujero redondo.
2. Marque en la pared las posiciones de los tres agujeros para el conector fijo inferior de la barra de ducha. Después de perforar, introduzca los tornillos de expansión.
3. Despegue la adhesivo 3M del conector y fíjelo a la pared con tornillos.
4. Conecte el tubo curvo superior a la barra de ducha y apriete los tornillos. Al mismo tiempo, retire los cuatro tornillos del conector de la barra de ducha e inserte la tapa decorativa en la barra de ducha, como se muestra en la Figura 4.
5. Inserte la barra de ducha en los dos conectores ya instalados, luego vuelva a apretar los cuatro tornillos.
6. Complete la instalación de la barra de ducha.

◆ **Conectar la Barra de Ducha, la Ducha de Mano y la Ducha Superior**

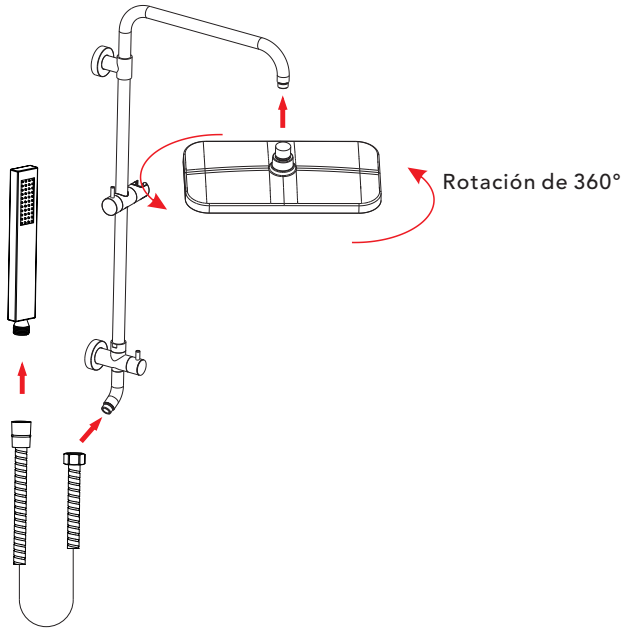

1. Apriete el conector de la manguera de ducha y el conector de la ducha superior en la dirección indicada en el diagrama para completar la instalación.
2. El rociador superior cuenta con rotación de 360°.