





# Airdog X3

## User Manual

### Warranty

The Company warrants, to the original purchaser only, this product to be free from defects in workmanship and materials under normal use and service (all except human matters) for 1 year from the date of receiving.

 Follow and like us on Facebook

 Customer Service : [support@AirdogUSA.com](mailto:support@AirdogUSA.com)

 Official Website : <http://airdogusa.com/>



Scan QR code for more Video Instructions  
(Airdog Youtube channels)



Please Recycle



# Purification Theory



# Packing List

Machine×1    Collecting plates×1    User Manual×1

# Components

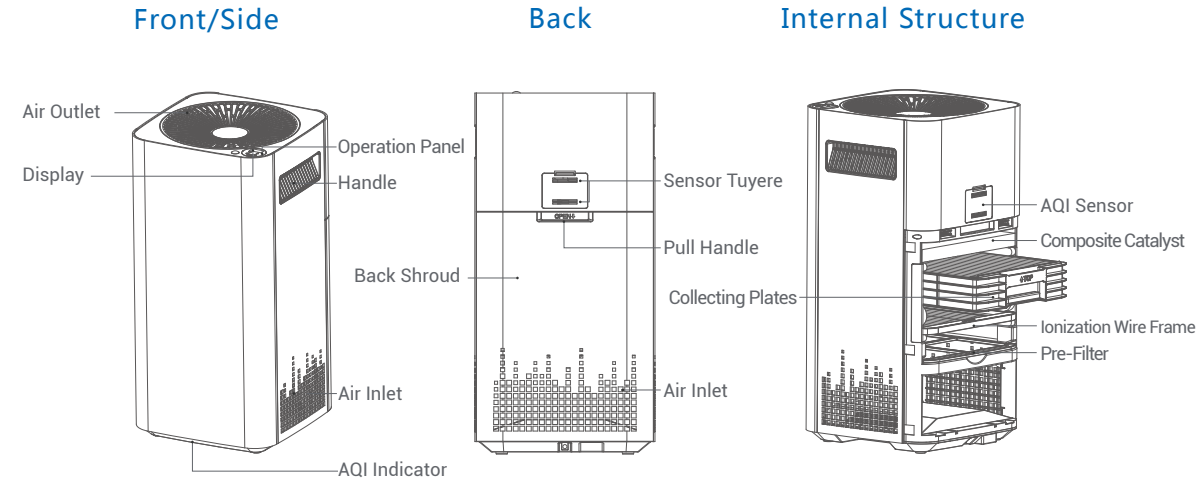

## Installation Guide

1. Take the collecting plates out of the foam box (if any styrofoam packaging pieces are on the plates, blow or brush them out before installing the collecting plates);
2. Use the pull handle to open the back shroud (Pic 1);
3. Insert the collecting plates in the orientation described on the label (Pic 2);
4. Close the back shroud and place the air purifier in an open location to achieve the best cleaning effects.

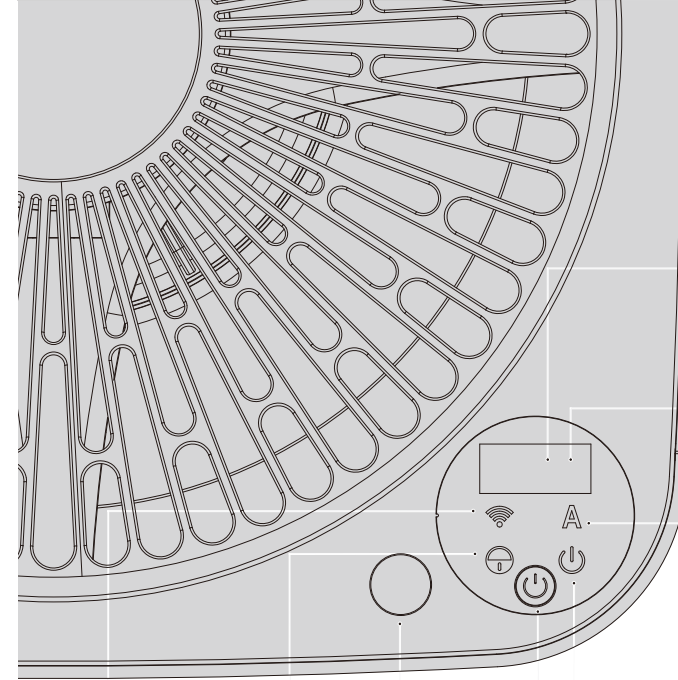
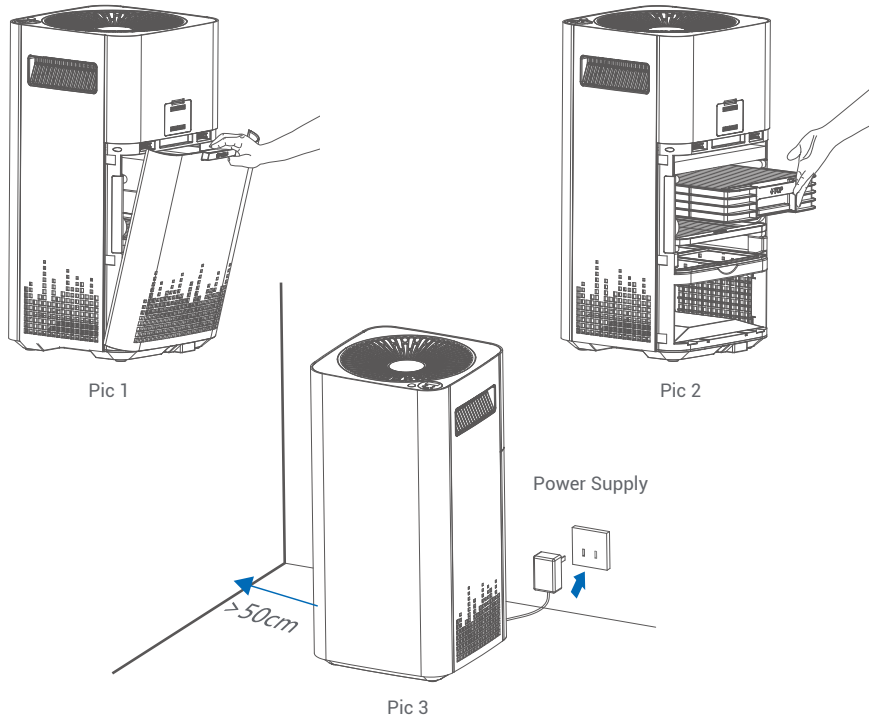

## Operation Instruction

### Sleeping Mode Indicator

Shows "..." on Sleeping mode, all other indicators are off, running on low speed.

### Wind Speed Indicator

Shows L1 to L4 to indicate fan speeds of Low (L1), Middle (L2), High (L3) or Turbo (L4).

### Auto Mode Indicator

1. Adjusts wind speed according to the AQI sensor.
  2. Runs on Sleeping mode at night automatically.
- When people pass by, the AQI indicator will be on as a night light. (\*For some models.)

### Power Indicator

Indicator lights up when the power is on.  
Indicator light is off when the power is off.

### Operation Button

1. A short press turns the power ON.
2. A long press (over 3 seconds) turns the power OFF.
3. When power is ON, each short press cycles through Auto-mode (default), Low speed, Middle speed, High speed, Turbo speed, and Sleep mode. Check indicator lights to understand each operation mode.
4. Hold a long press (5 - 10 seconds) until air purifier turns ON, WiFi indicator blinks quickly, and WiFi connection starts.

### WiFi Indicator

Off: no connection  
Quick Blink: start to connect  
Slow Blink: connecting now  
On: connected successfully

### Detector

Used to detect if there are people around, don't press it.

### Child Lock

Indicator On:  
Child Lock function on.  
Cannot operate on panel.  
Long press operation button to cancel, or cancel it by APP.

## Display and Air Quality Indicator Instruction

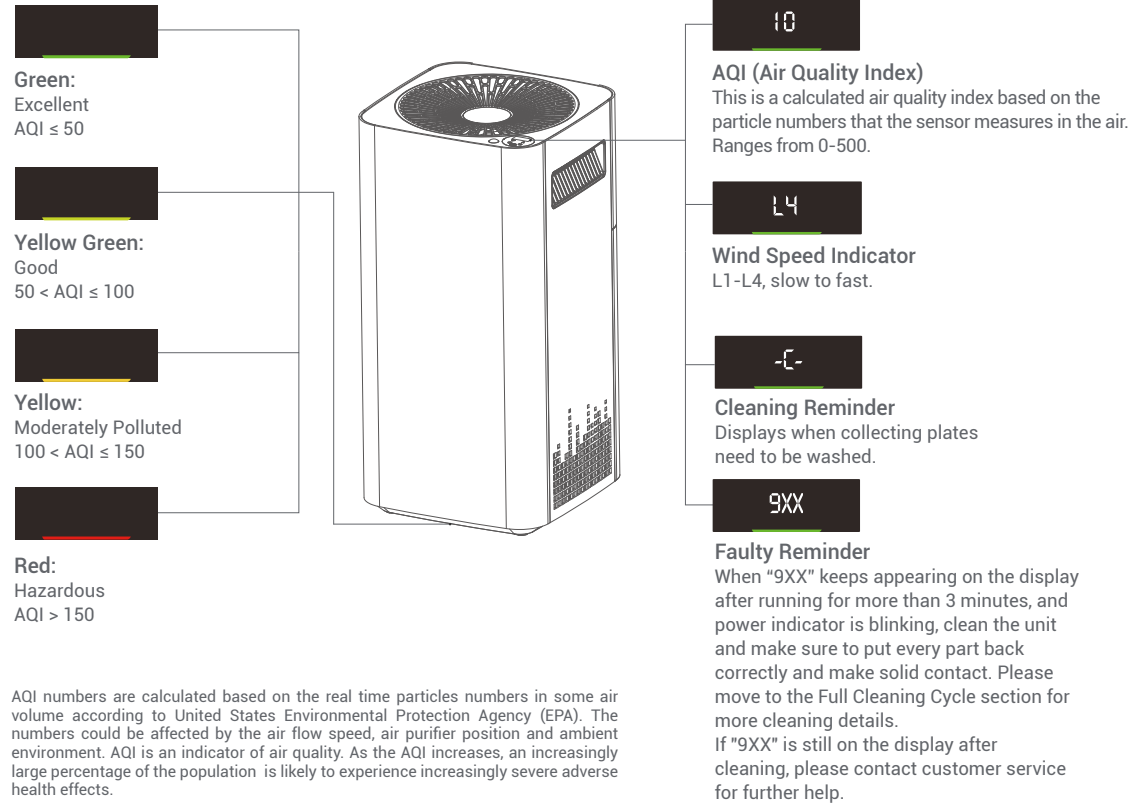

## Collecting Plates Cleaning

1. Clean the collecting plates when the air purifier displays "-[-]".
2. Turn off the power and unplug the unit. Wait 5 minutes. Then open the back shroud and pull out the collecting plates (Pic 1).
3. Follow the instructions on Pic 2 and Pic 3.
  - a. Slide to separate the seat and collecting part.
  - b. Separate the upper collecting part and bottom collecting part to wash.
4. Dry the collecting plates after cleaning (recommend over 24 hrs of drying time).
5. Put back the collecting plates in the direction of labeling.
6. Long press the Operation Button to clear "-[-]" and reset.

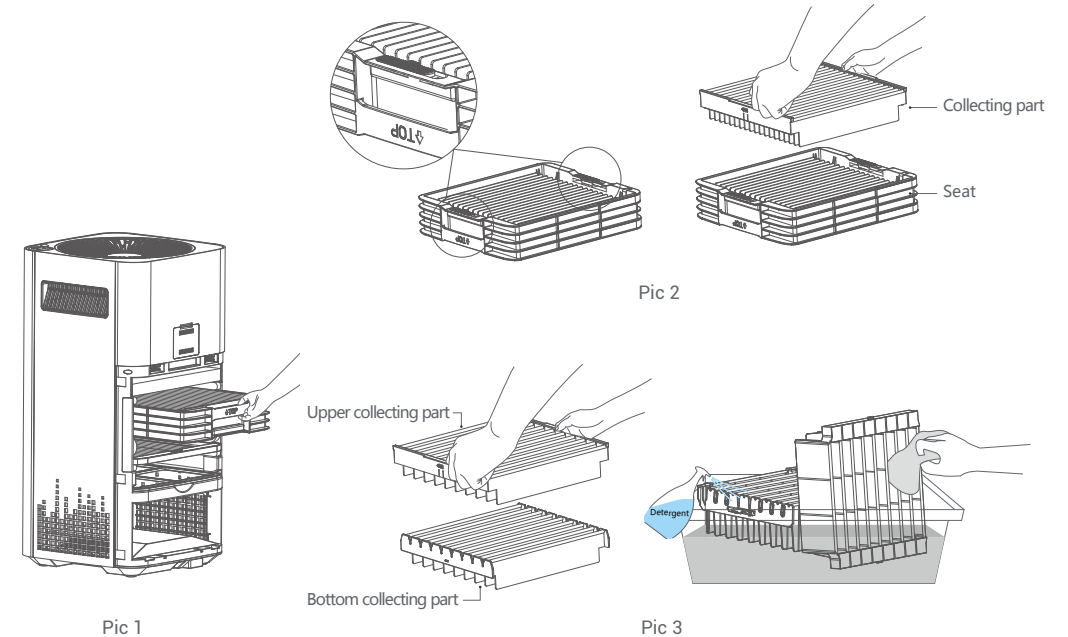

## Full Cleaning Cycle

1. We recommend a complete cleaning every 6-12 months.
2. First, unplug the power supply. Open the back shroud. Pull out the ionization wire frame and collecting plates. Pull out the protective rubber sleeve as illustrated (in Pic 1).
3. Clean the ionization wire frame very gently with a soft sponge, wiping in 1 direction, and clean the collecting plates with water and a rag.
4. Use a wet cloth to wipe down all surfaces of the protective rubber sleeve, including notches. For better results, wash the entire rubber sleeve in water.
5. Clean the inner walls of the air purifier with a soft cloth (Pic 2).
6. Wash the pre-filter in water, clean it by vacuum, or brush it gently with a soft brush.
7. Dry the parts completely, 100% dry, and then put them back in order.

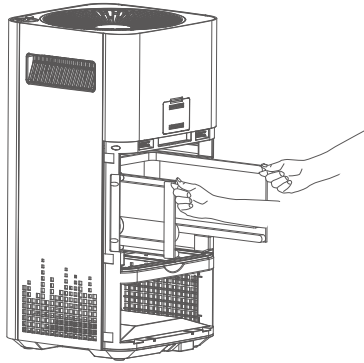

Pic 1

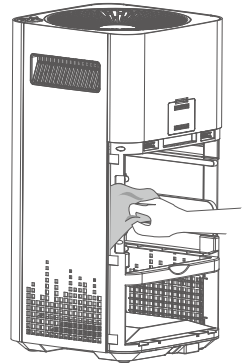

Pic 2

## Air Quality Sensor Cleaning

Airdog air purifier has an embedded air quality sensor. To keep the air quality sensor reading correctly, please clean the sensor every 6 months, using a dry soft rag or cotton swabs with rubbing alcohol as illustrated.

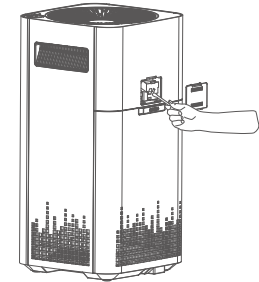

Pic 1

## Reminder

1. Please take out the line cord directly from the back (Pic 1). DO NOT coil or run the power cord under the bottom of the air purifier. Keep it free and clear from obstructions (Pic 2, Pic3).
2. ONLY use the original adapter.
3. Follow the instructions above to avoid creating problems with the electromagnetic compatibility of the purifier.

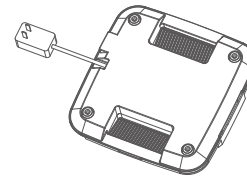

Pic 1 Correct

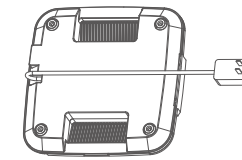

Pic 2 Wrong

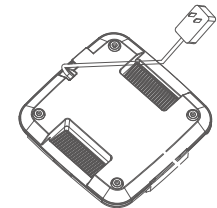

Pic 3 Wrong

## Important Notices! Follow All of These Instructions!

### Cleaning and Usage Notices:

1. Turn off the power and unplug the unit before performing any cleaning or maintenance.
2. This is an advanced electronic smart appliance using high voltage but very low current inside. It is built for safety. Always wait 5 minutes after turning off the power and unplugging the unit before opening up the back shroud to allow the unit to dispense of built-up internal static.
3. ONLY use the original adapter.

### Safety Notices:

1. To prevent damage to the inner components, avoid impacts or dropping the unit.
2. Keep purifier away from children.
3. Do not block or put objects into the Air Inlet or Air Outlet.
4. Do not touch the power plug with wet hands.

### Placement Notices:

1. Do not use it around flammable or explosive environments with combustible gas or dust.
2. Do not use it in wet environments (for example: beside a humidifier).
3. Do not use it near a heat source or in a high temperature environment.

## App Setting

Please keep your Wi-Fi on to help you finish your App setting.

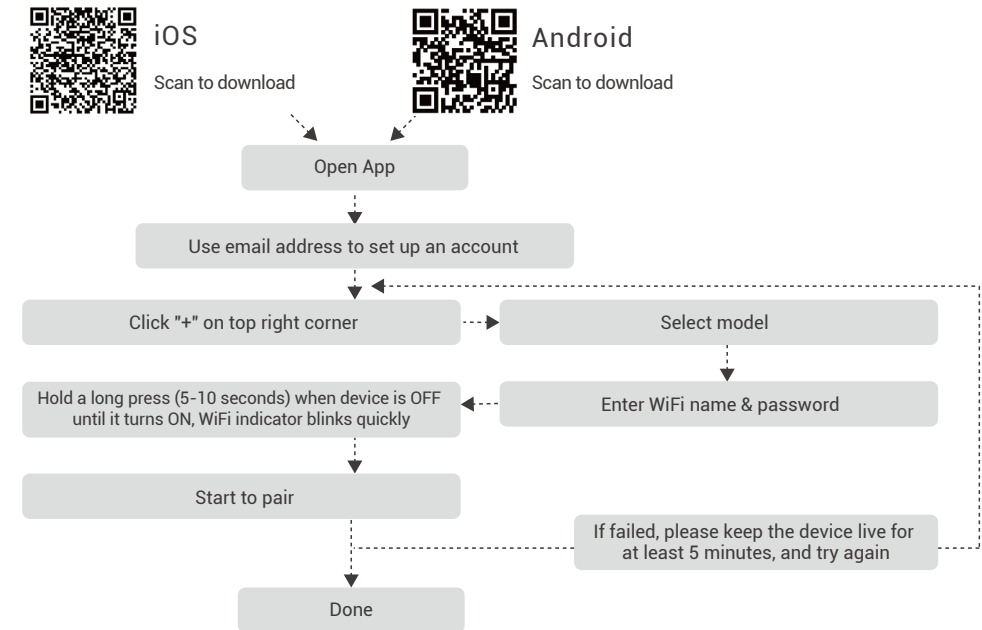

## Q&A

### Q1: I am concerned about the product safety. May I know more details?

Airdog X3 is built around Safety 1st! We have implemented the following:

- A. Smart control: The "smart electronics" control circuit continually monitors the current and voltage levels, and suppresses them whenever there's any abnormal situation;
- B. Anti-fire: Airdog X3 is manufactured with the highest V0-grade fire retardant plastics housing;
- C. Child lock: It prevents improper operations when children are playing around it;

### Q2: Airdog X3 uses high voltage inside. Is it safe for home use?

Airdog X3 uses an advanced electronic design built around safety. The power consumption of Airdog is equivalent to only a small light bulb! It has high voltage inside but very low current in the order of micro-amps. The high voltage runs on direct current to avoid any possible electronic perturbation.

### Q3 : Do I have any maintenance cost if I own an Airdog X3?

Airdog X3 is a cost effective and environmentally green solution.

- A. Collecting plates in Airdog X3 is a washable and reusable part, so no more need on spending money on HEPA filters.
- B. Composite catalyst layer is also reusable; you may put it directly under the sunlight for 1~2 hours to refresh it. However, some customers might be very sensitive to any smell and desire to change the composite catalyst layer every 6-24 months to refresh the smell. The cost of the catalyst layer is only a small fraction of the cost of HEPA. To replace the catalyst layer, please contact your sales resource where you bought Airdog X3.

### Q4: How can I know that my air purifier is really cleaning the air?

The best part of Airdog X3 air purifier is that you could see the effect with your own eyes! You will notice the AQI (Air Quality Index) number decreasing when the air purifier is on. Also, after using X3 for a week, you can actually see many of the pollutants absorbed on the collecting plates when you take the plates out to clean.

### Q5: Why is the AQI display abnormal on the LCD screen? It's displaying "-C-" or "9XX" instead of numbers?

Display of "-C-" means it is time to do a cleaning.

The "9XX" is an electronics abnormal signal. Please unplug the unit and do a full clean cycle and restart. If the "9XX" still exists, please contact customer service for further instructions.

### Q6: Why isn't the AQI display changing numbers?

The dust accumulated on the sensor could cause the sensor to be insensitive to reading the air quality. Please clean the sensor with a dry cloth or a cotton swab with alcohol.

### Q7: I heard a "cracking" or "zapping" noise inside the unit. Is that normal?

The occasional "zapping" or "cracking" is normal when bigger particles enter the air purifier and are being zapped by the high voltage, similar to when a bug zapper traps a bug. However, if the "cracking" or "zapping" noise is constant, you should clean the unit and make sure that all parts in the unit are fully dried after you clean the unit. Approximately 80% of noise issues are caused by either dust/particle accumulation on the collecting plates and/or inner chamber, or by wet collecting plates. Normally a full clean cycle will take care of this all.

### Q8: When should I do a full cleaning cycle?

- A. When "-C-" is on the display screen.
- B. When "9XX" keeps appearing on the display after running for more than 3 minutes even after cleaning the collecting plates.
- C. "Cracking / zapping" sounds still exist after cleaning the collecting plates.
- D. The unit shutdowns and restarts automatically.

Note: Please refer to the "Full Cleaning Cycle" section in the user manual for details.

**Q9: Can I clean Airdog X3 by putting the whole unit in the dishwasher?**

You should not put the whole Airdog X3 unit into the dishwasher! Only the collecting plates is OK to be washed by a full wash cycle. Please make sure the collecting plates unit is fully dried before putting it back into your Airdog X3. There could be water residue inside of the collecting plates even after the drying cycle sometimes, so make sure to take the time to fully dry them.

**Q10: Why does Airdog App connection fail?**

- A. Airdog App does not support IPv6 network environment.
- B. Make sure your Wi-Fi is in 2.4GHz.
- C. The home Wi-Fi environment can be complicated. To verify if the smart control system is functional or not, you can use the hotspot on another phone instead of the home Wi-Fi to try to make a connection. The hotspot could simplify connection complexity and verify the hardware functionality.
- D. We have finished the App and server migration. Please double check the label on the back of your unit. If it is a green matrix code you are good to download the "Airdog Pro" App and connect. If it is a blue matrix code, please check whether your firmware is upgraded or not.

For more details, please visit the Official Website for the App Guide.

# About Airdog X3

Model	KJ200F-X3
Applicable area (m <sup>2</sup> )	20 * <sup>1</sup>
CADR <sub>particle</sub> (m <sup>3</sup> /h)	200
CCM <sub>particle</sub>	P4 * <sup>2</sup>
Purification Efficiency Level <sub>particle</sub>	High Efficiency Level
Ozone (ppb)	≤10 (Safety Standard≤50)
Noise (dB(A))	≤58
Rated Power (W)	27
Rated Voltage	13V <sup>⎓</sup>
Weight (Lbs)	11
Size (Inches)	20.5(H) * 10.2(L) * 10.2(W)

All figures above are all under the international standards of Air Purifier.

This product complies with the maximum allowable concentration of ozone of 0.050 parts per million by volume (ppmv) in a 24-hour period. The Health Canada Guideline 2010 recommends that the maximum exposure limit, based on an averaging time of 8 hours, is 0.020 ppmv or less when tested in a sealed, controlled room approximately 30 m<sup>3</sup>.

Ce produit est conforme avec la concentration maximale présumée d'ozone de 0,050 parties par million par volume (ppmv) pendant une période de 24 heures. La Ligne directrice (2010) de Santé Canada recommande un niveau maximal d'exposition, basé sur un moyen de 8 heures, soit 0,020 ppmv ou moins dans une chambre de teste étanchée et contrôlée de 30 m<sup>3</sup>.



Designed by Silicon Valley Air Expert  
Manufactured by Anhui BeiAng Air Tech Ltd.  
No.15, Exi Rd., San Shan District, Wuhu, Anhui