

ASSEMBLY INSTRUCTIONS

SHK - SHAKER STYLE PANEL PLATFORM BED

FULL SIZE / QUEEN SIZE

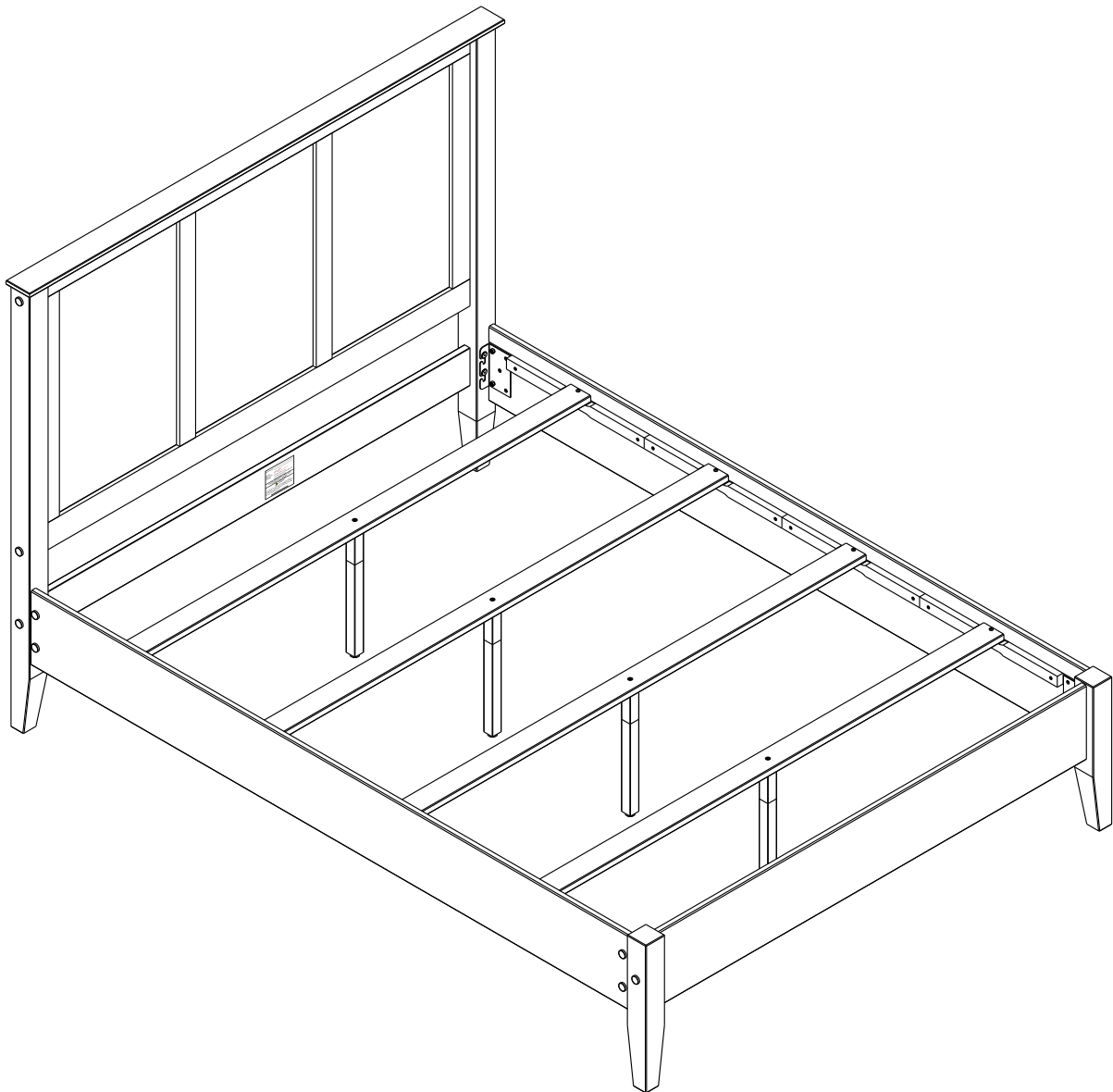

IMPORTANT NOTE:

- * Read and observe carefully all the assembly instructions before beginning assembly.
- * The assembly of the product must be done on a clean and flat surface. We suggest to use the packaging to cover the floor to avoid damages.
- * The screws must be tightened periodically.
- * Avoid contact with sharp objects.
- * Avoid banging pieces together.

PARTS INCLUDED



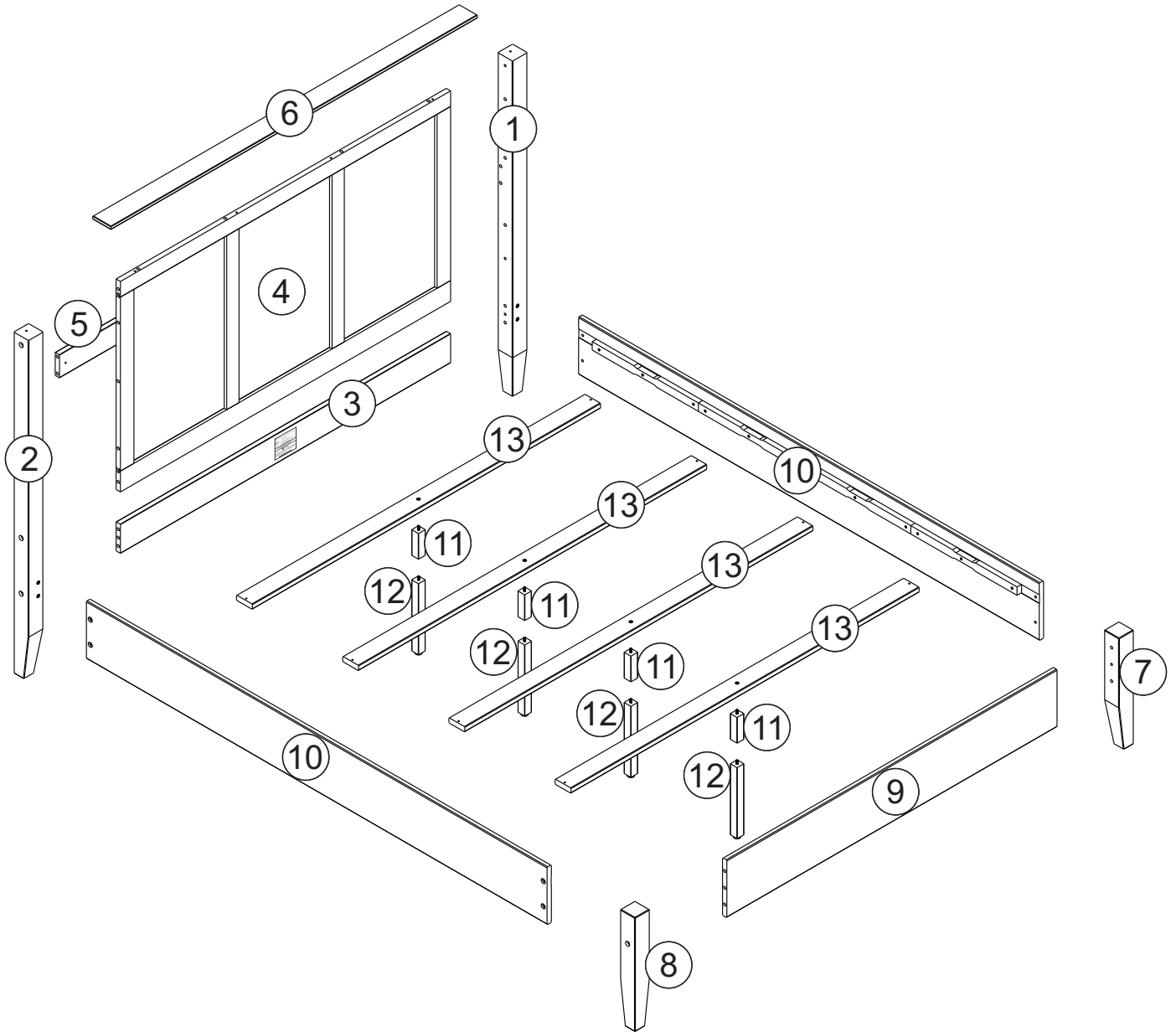





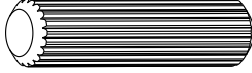
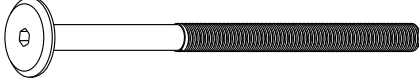

Please confirm all parts available before assembly.

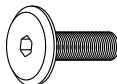

Tools (not included)				
<p>01:10 Min Approximately</p>	<p>02 Persons</p>	<p>Clean surface</p>	<p>Philips key</p>	<p>Hammer</p>

HARDWARE INCLUDED

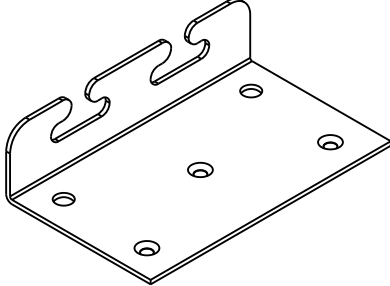
Please confirm all hardware available before assembly.

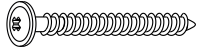
Ref.		Qty.		Qty. SPARE
A	 Ø10 x 40 mm	22	+	02
B	 Ø1/4" x 100 mm	08	+	01
C	 Ø1/4" x 40 mm	08	+	01
D	 Ø1/4" x 20 mm	08	+	01
E	 Ø4,5 x 35 mm	16	+	02
F	 Ø3,5 x 16 mm	12	+	02
G		08	+	01
H		08	+	01
I		16	+	02
J		01	+	01
K		04		
L		01		
M	 Ø4,5 x 45 mm	02		

OPTION 01

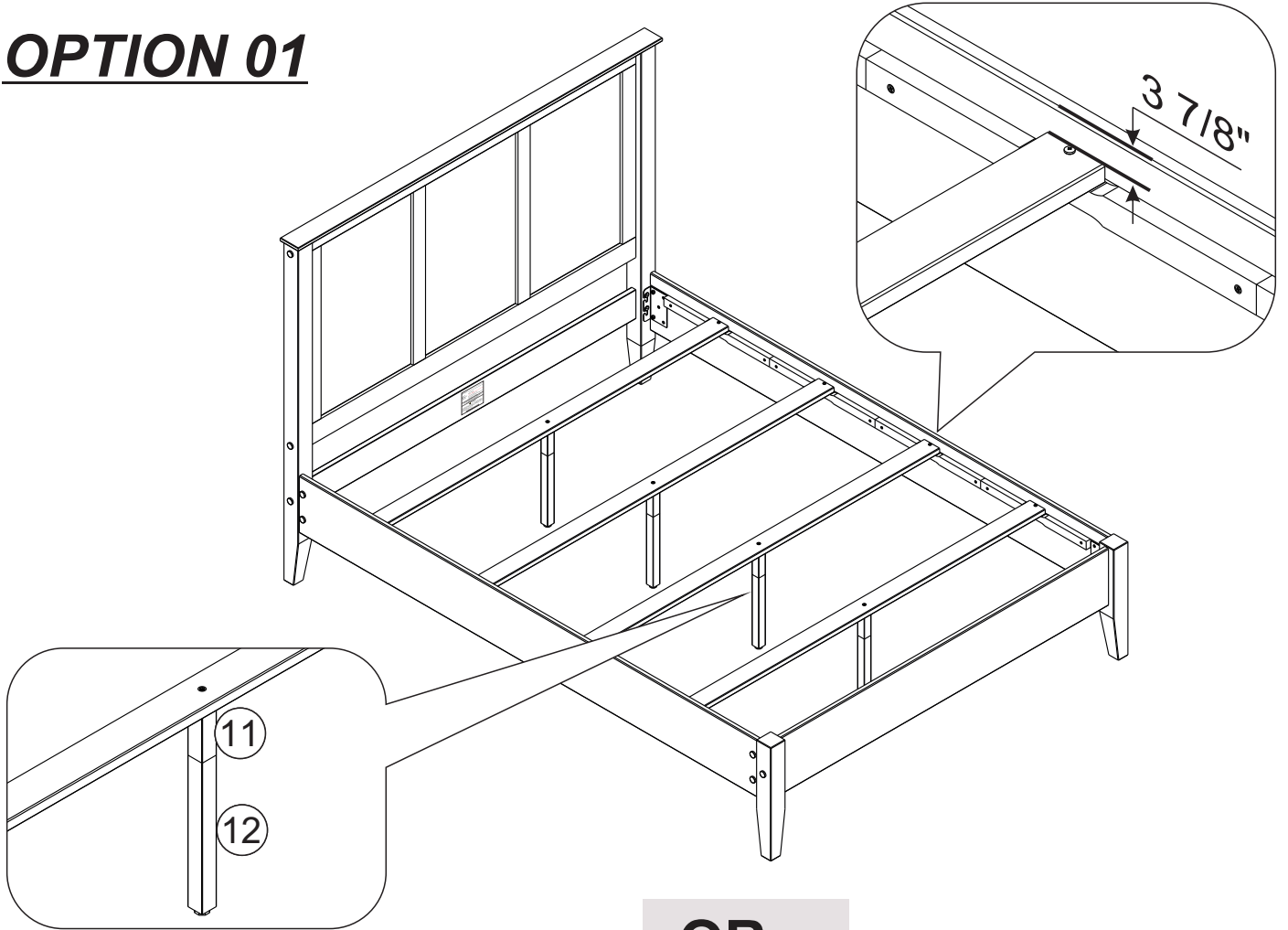

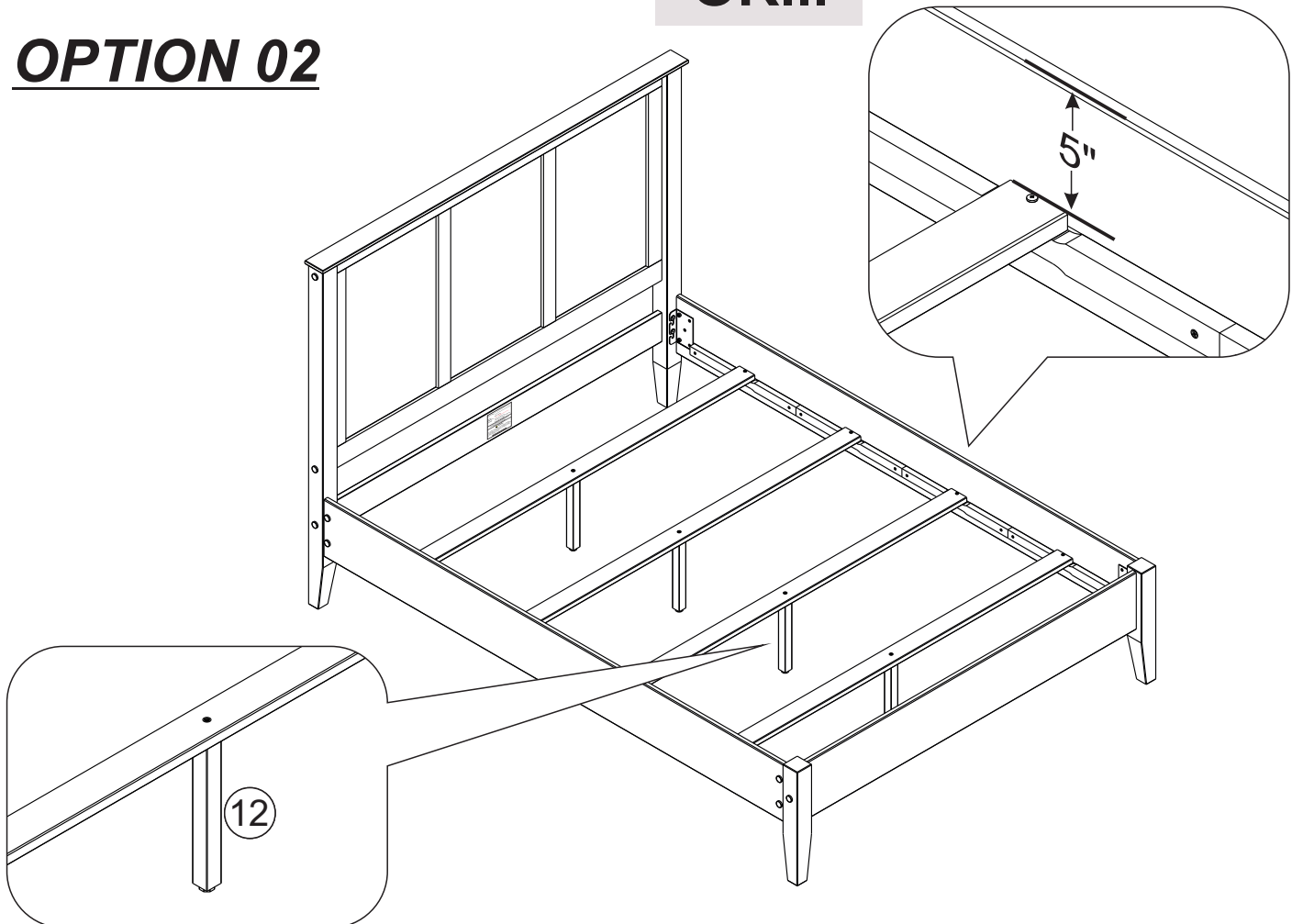

OR...

OPTION 02



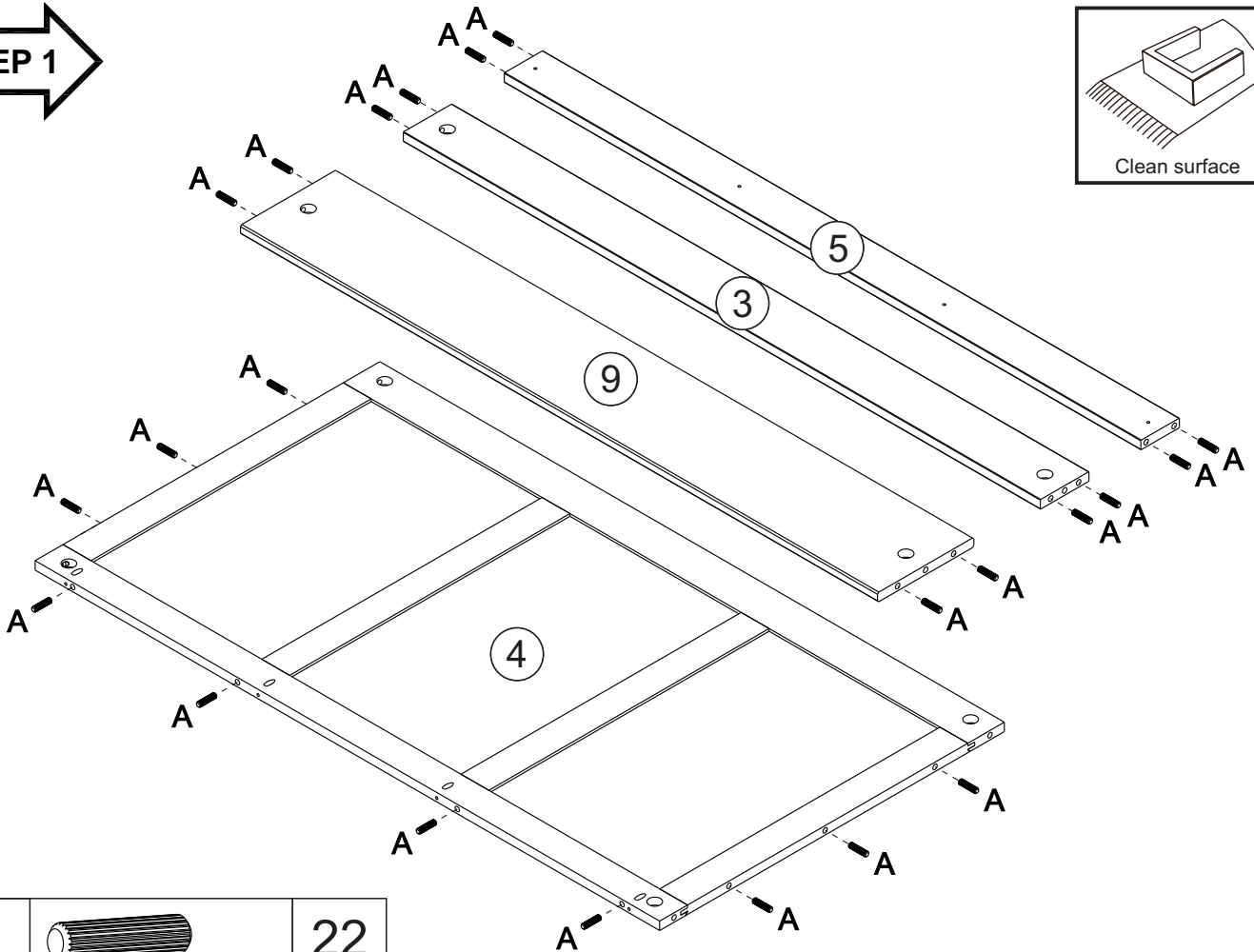



STEP 1



A		22
<small>Ø10 x 40 mm</small>		

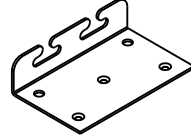

STEP 2

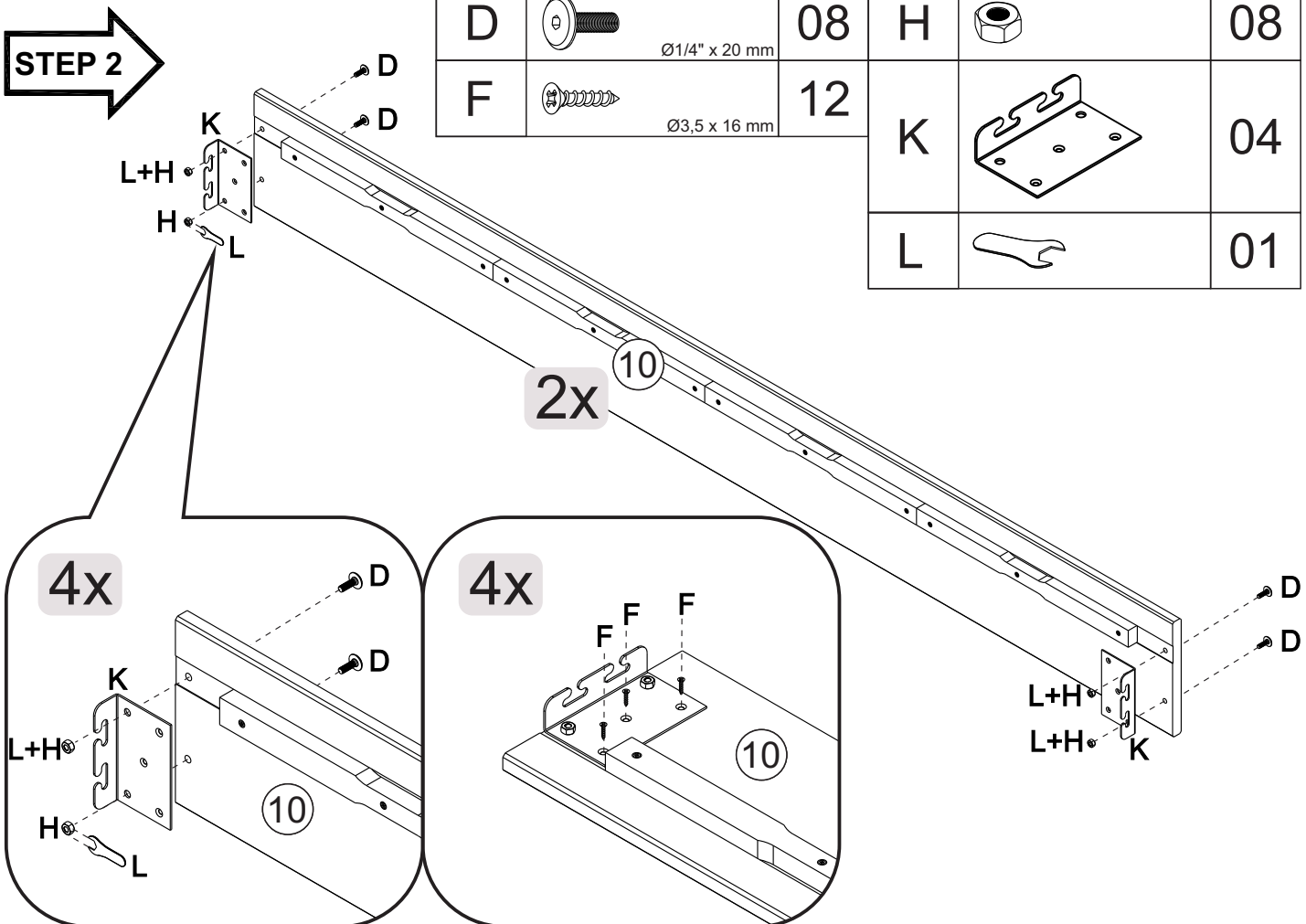
D		08	H		08
F		12	K		04
	<small>Ø1/4" x 20 mm</small>		L		01
	<small>Ø3,5 x 16 mm</small>				



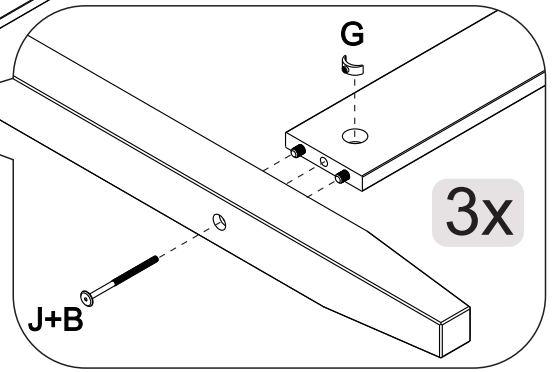
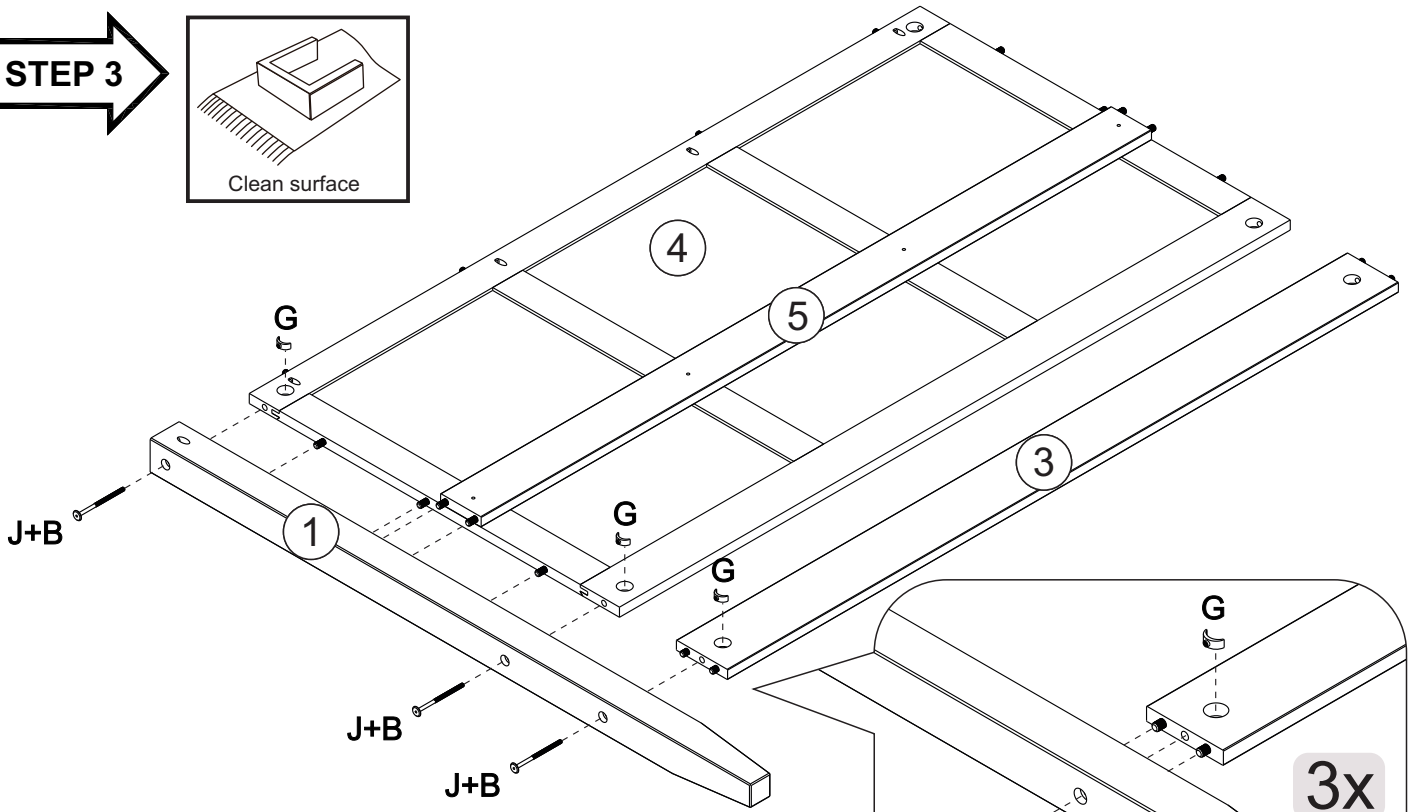
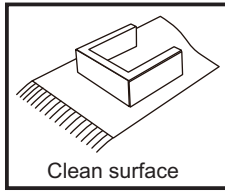

STEP 3

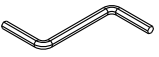

B		03			
	$\varnothing 1/4" \times 100 \text{ mm}$				
G		03	J		02

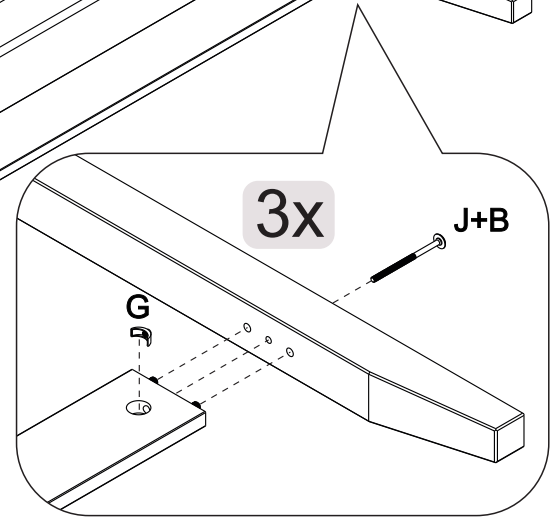
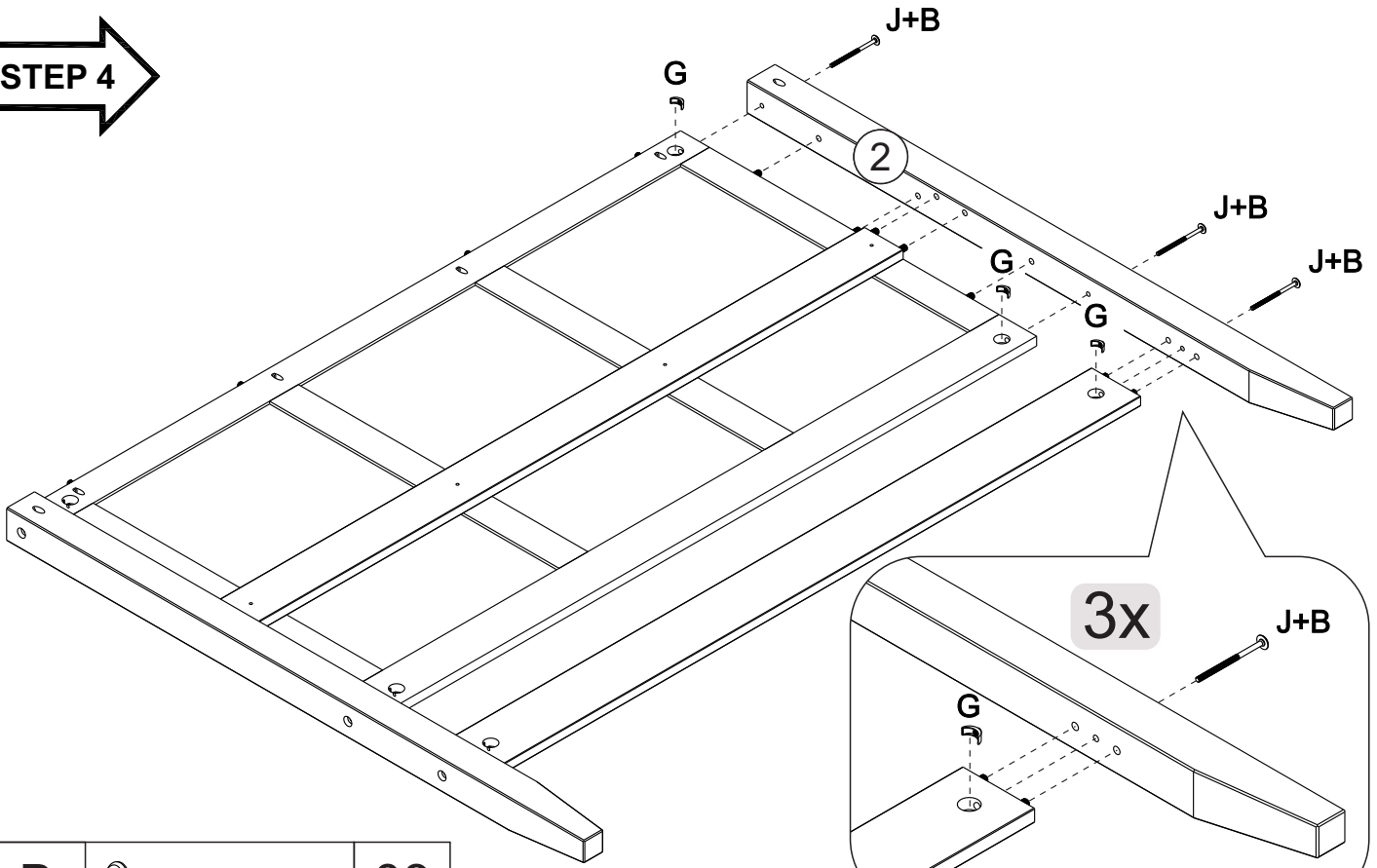
STEP 4

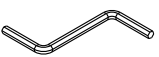

B		03			
	$\varnothing 1/4" \times 100 \text{ mm}$				
G		03	J		02

STEP 5

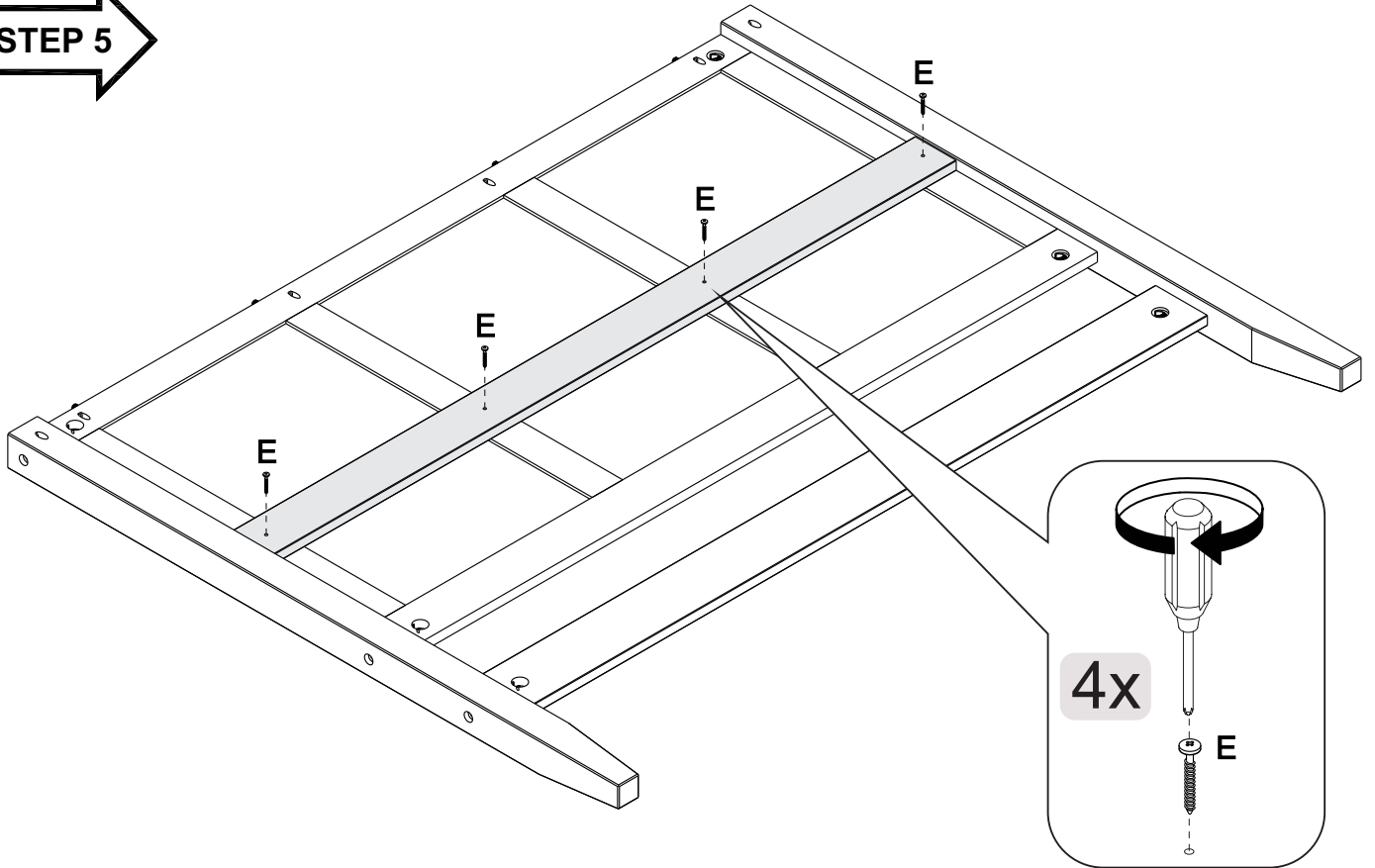

E		Ø4,5 x 35 mm	04
---	---	--------------	----

STEP 6

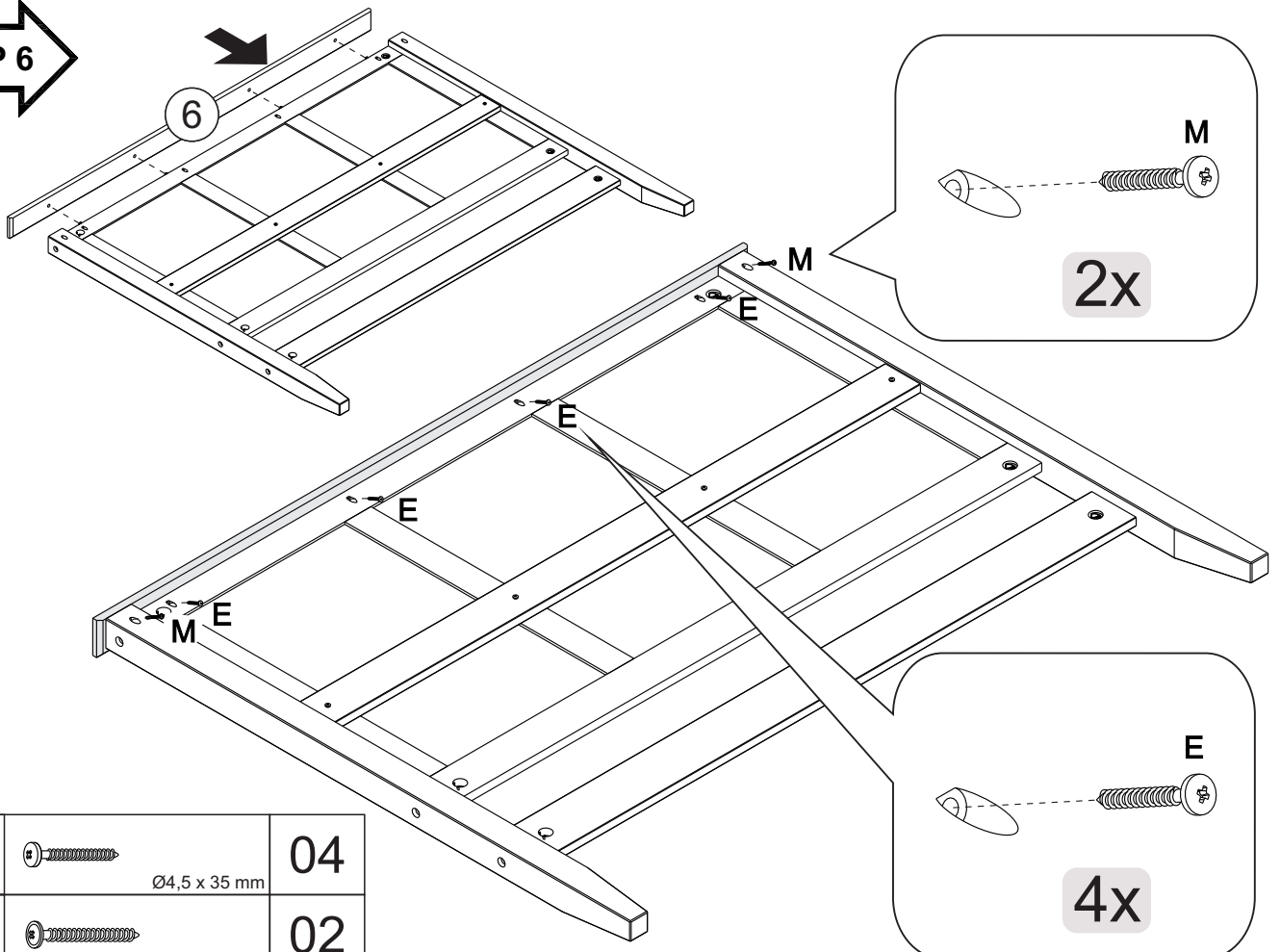

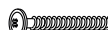

E		Ø4,5 x 35 mm	04
M		Ø4,5 x 45 mm	02

STEP 7

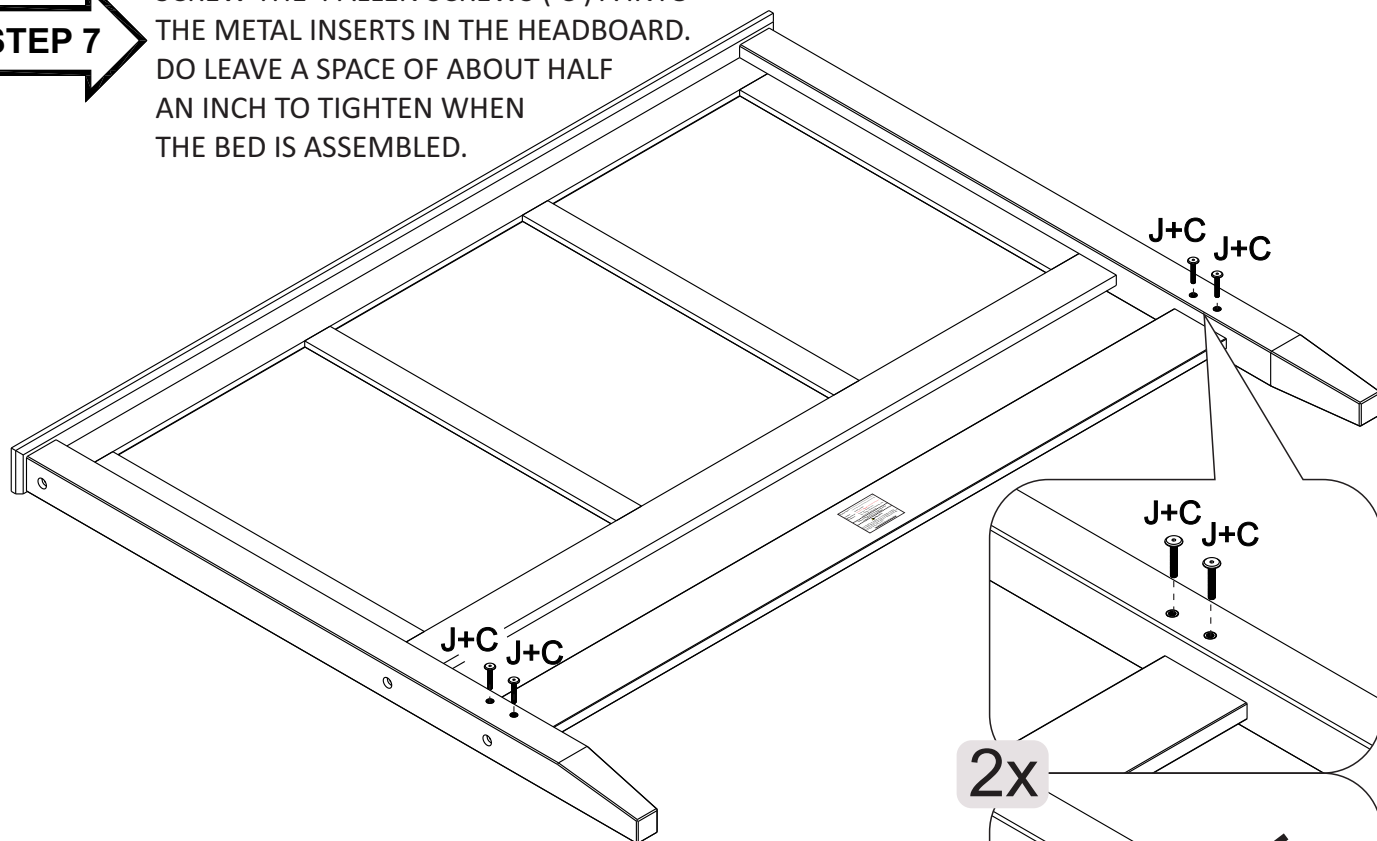

SCREW THE 4 ALLEN SCREWS (C) A INTO THE METAL INSERTS IN THE HEADBOARD. DO LEAVE A SPACE OF ABOUT HALF AN INCH TO TIGHTEN WHEN THE BED IS ASSEMBLED.



C	 Ø1/4" x 40 mm	04
J		02

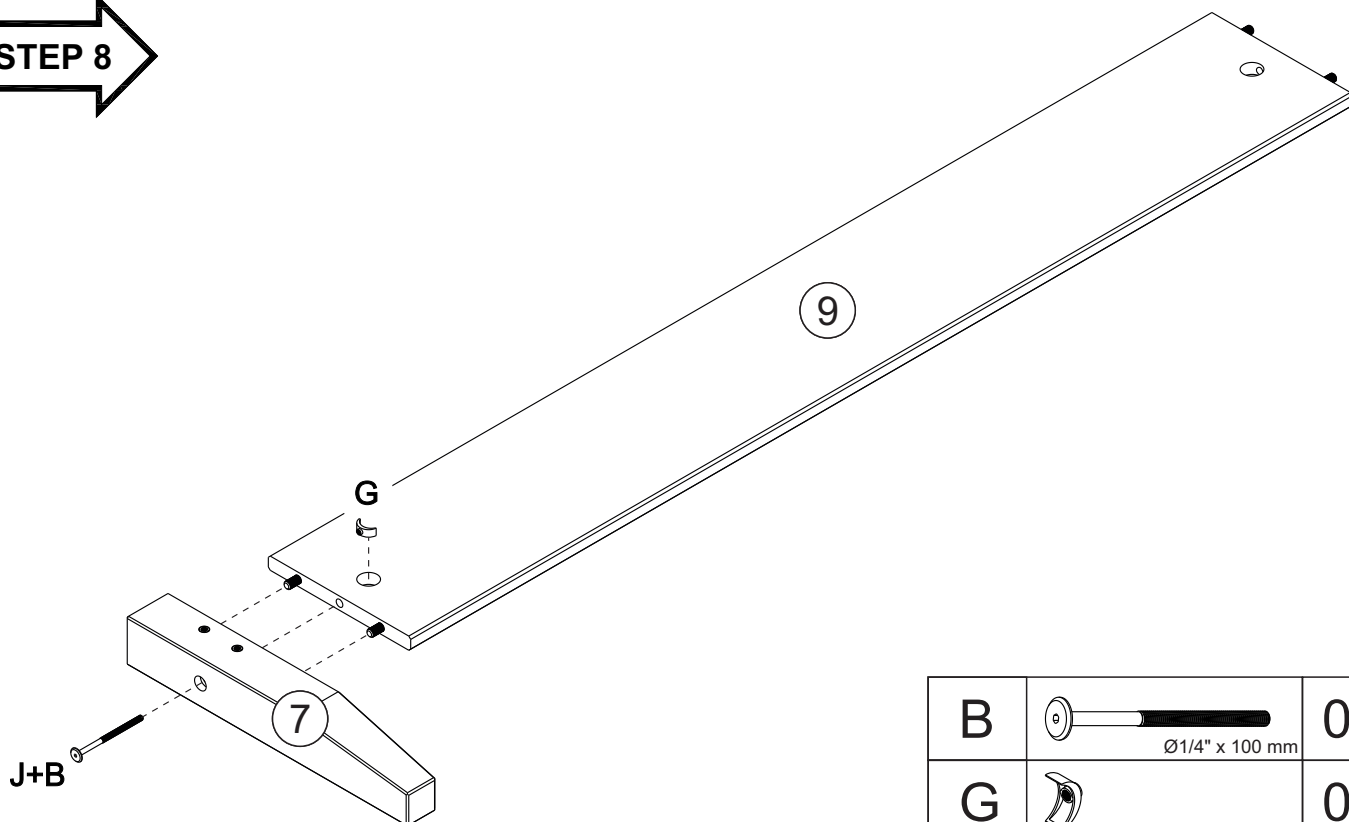

STEP 8

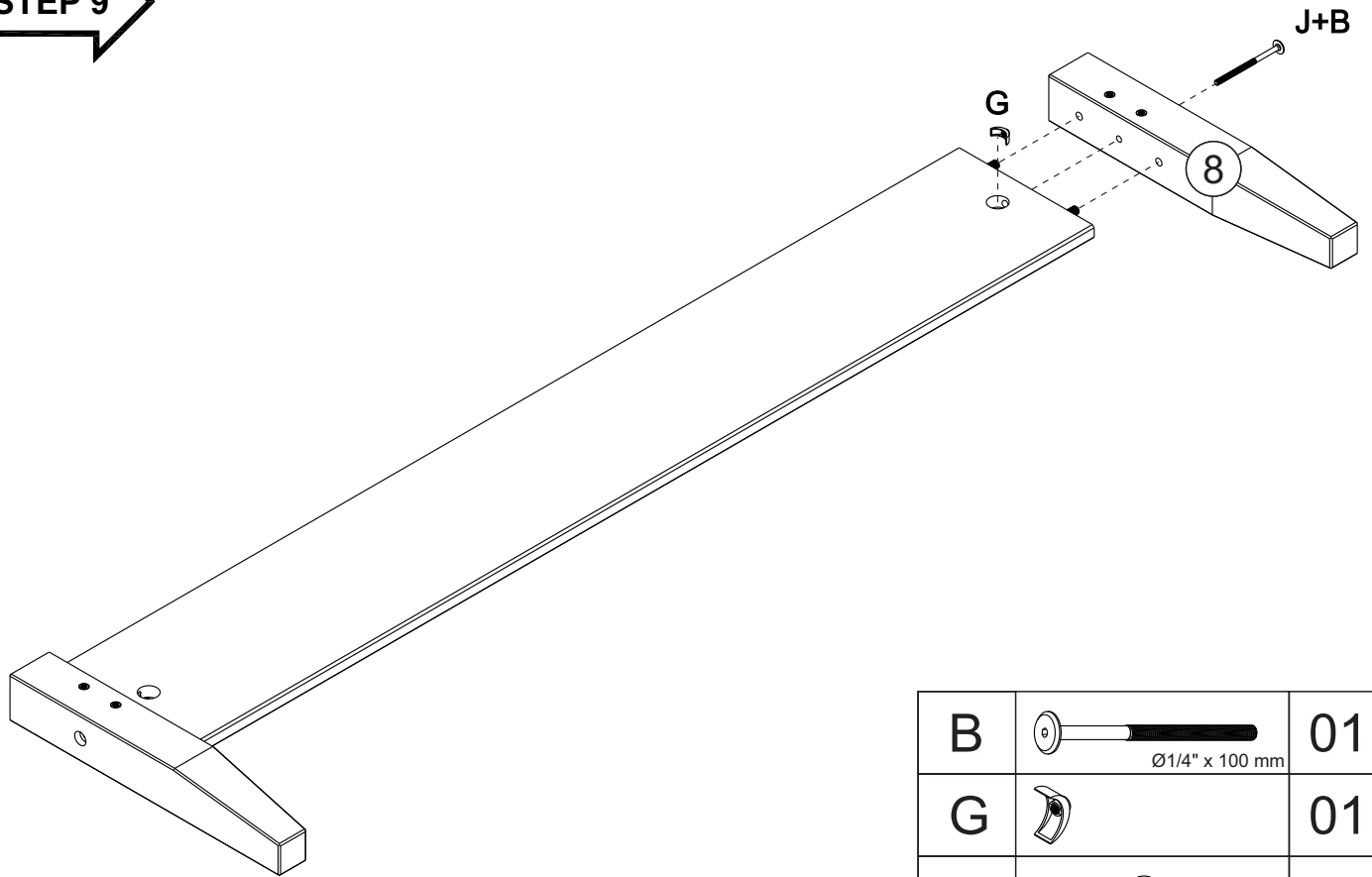

B	 Ø1/4" x 100 mm	01
G		01
J		01

STEP 9

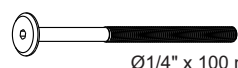

B	 $\varnothing 1/4" \times 100 \text{ mm}$	01
G		01
J		01

STEP 10

SCREW THE 4 ALLEN SCREWS (C) A INTO THE METAL INSERTS IN THE FOOTBOARD. DO LEAVE A SPACE OF ABOUT HALF AN INCH TO TIGHTEN WHEN THE BED IS ASSEMBLED.

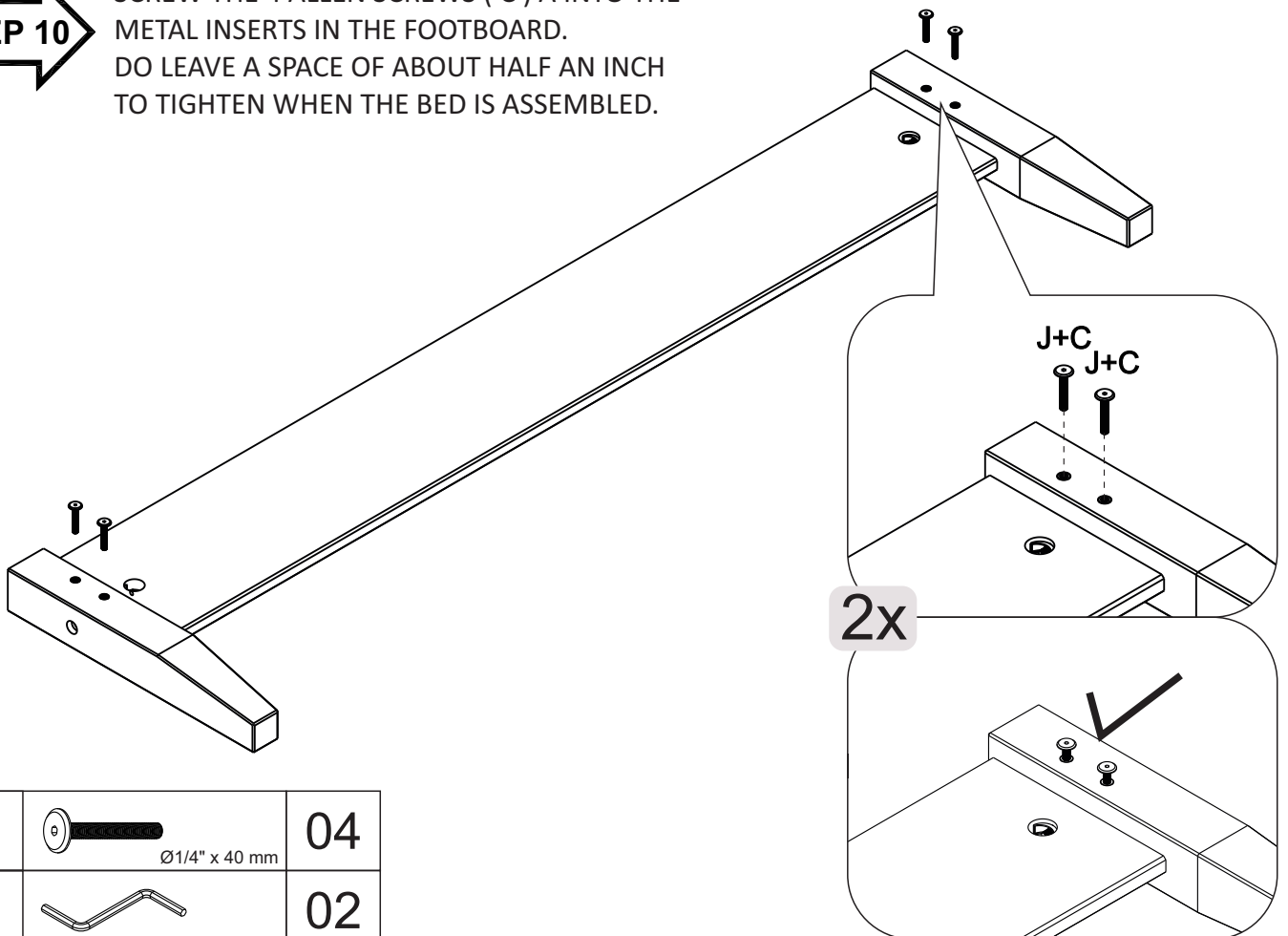

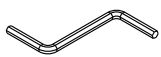
C	 $\varnothing 1/4" \times 40 \text{ mm}$	04
J		02

STEP 11

OPTION 01

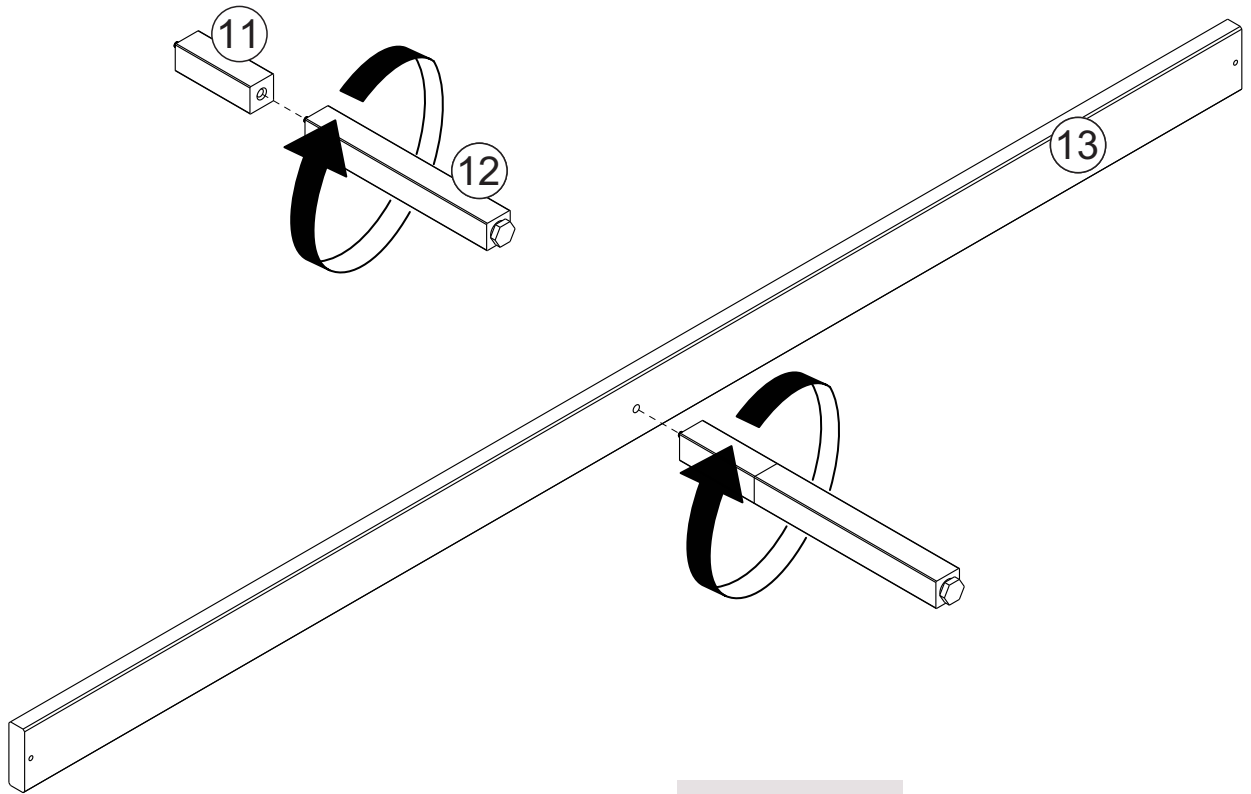

OR...

STEP 12

OPTION 02

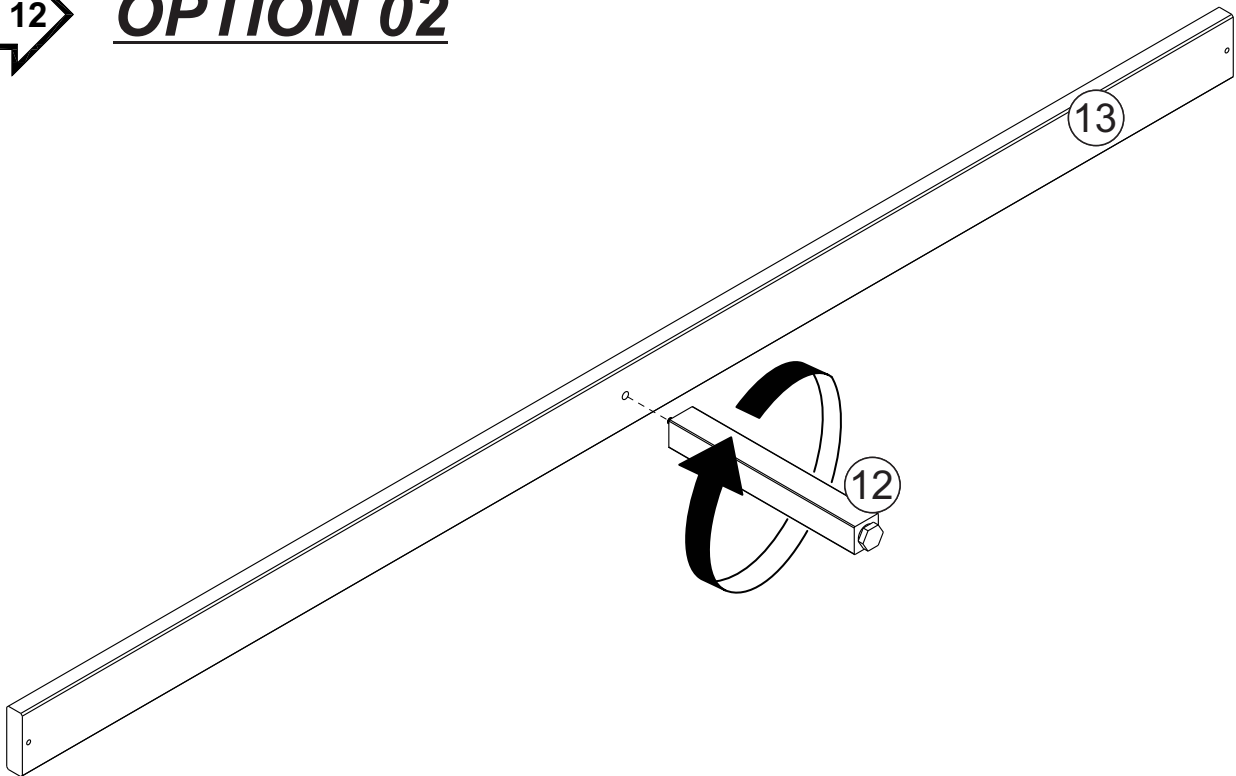

STEP 13

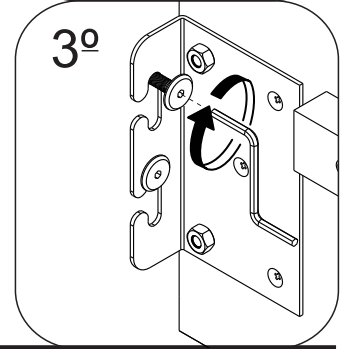
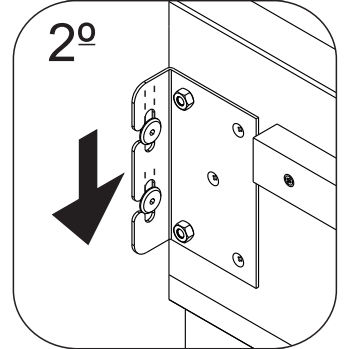
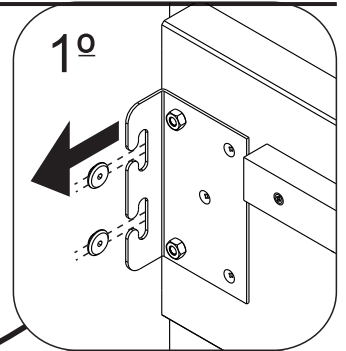
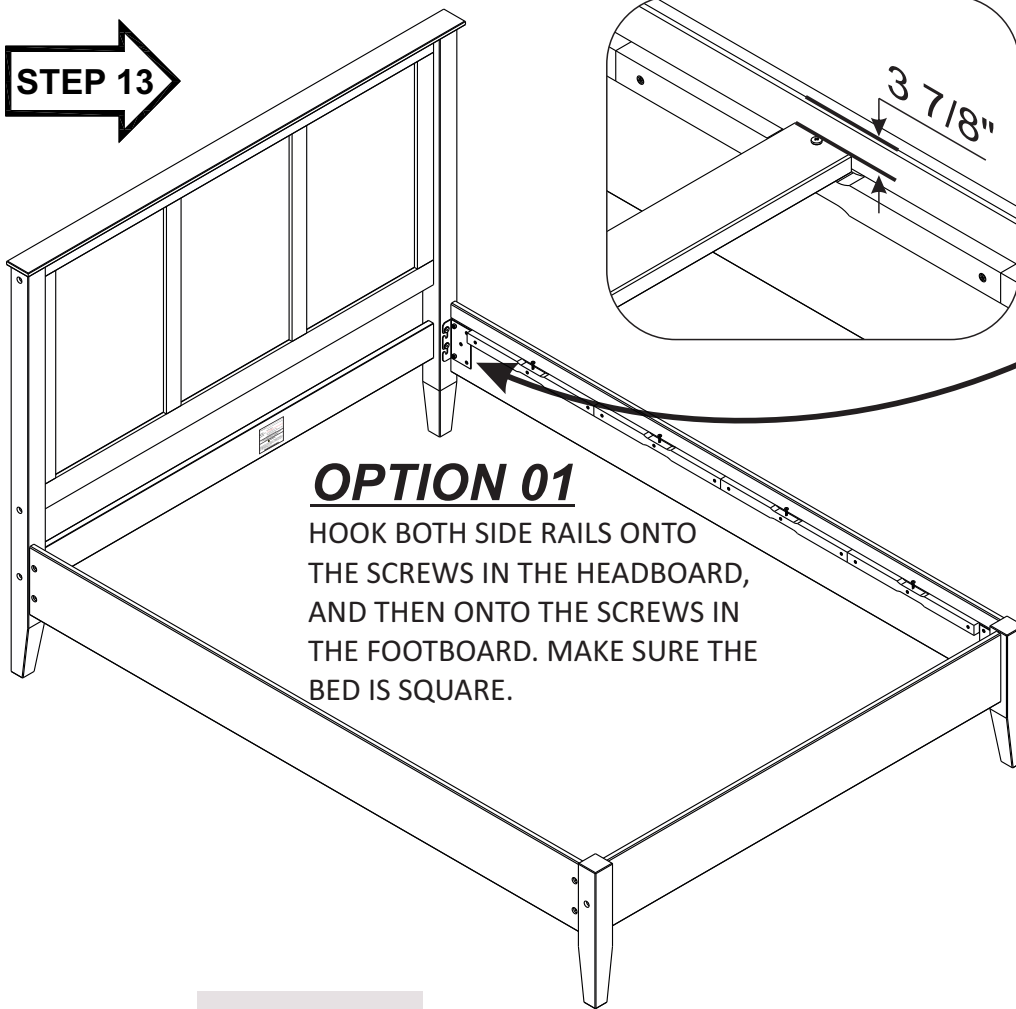

OR...

STEP 14

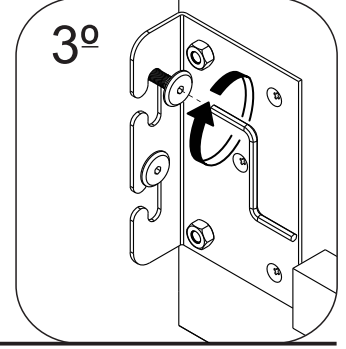
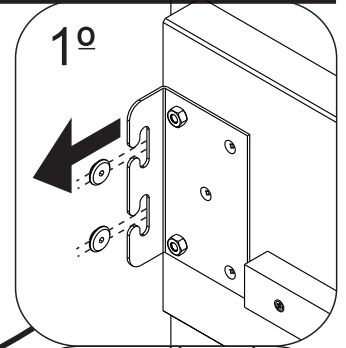
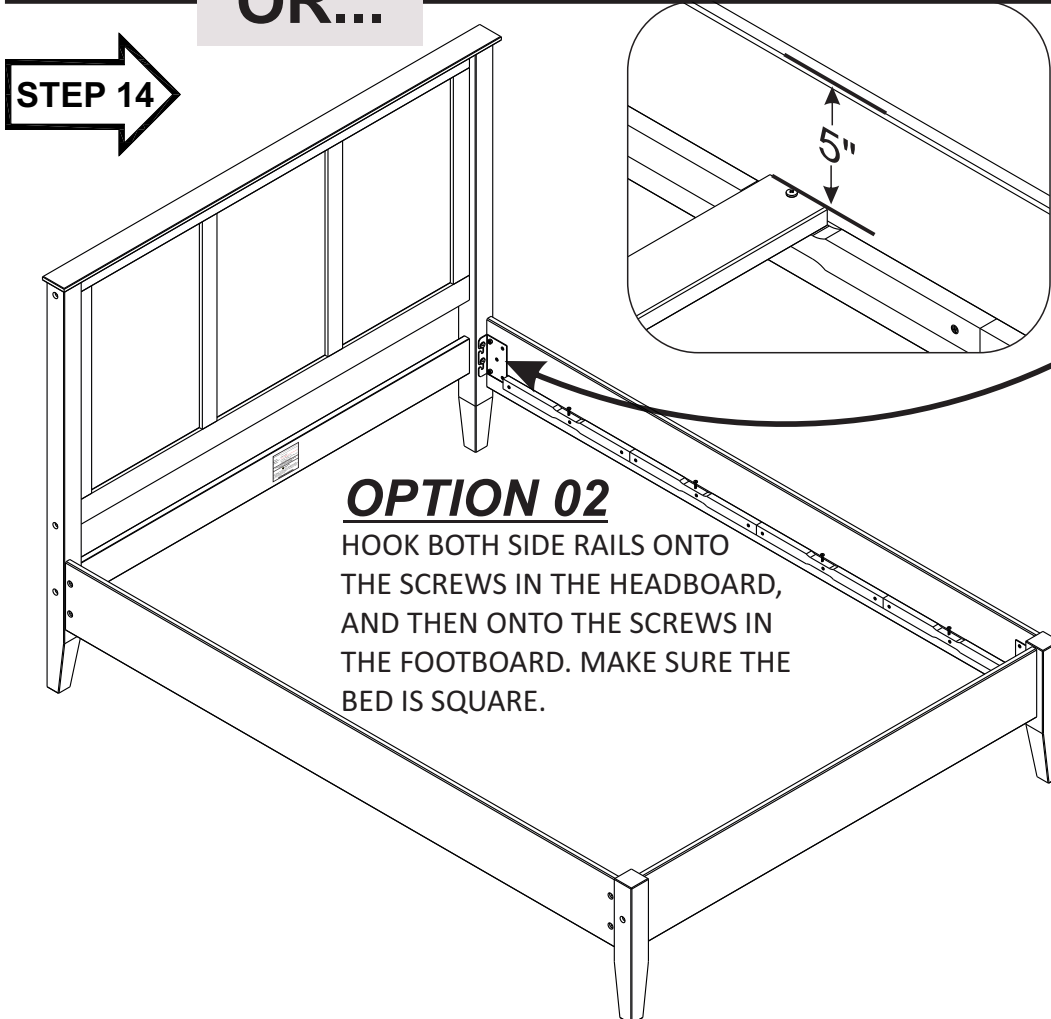

STEP 15

OPTION 01

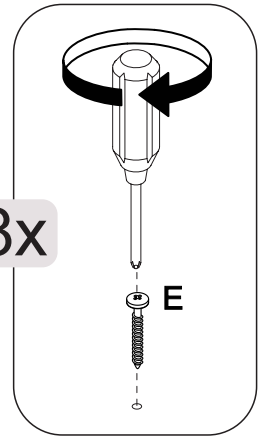
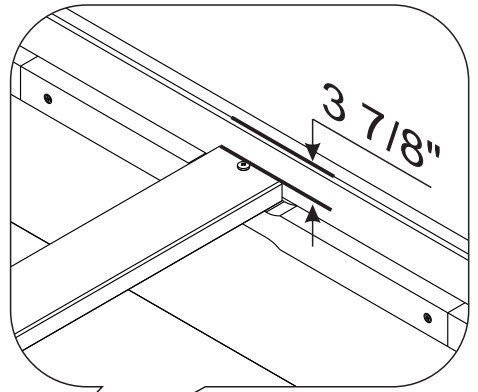
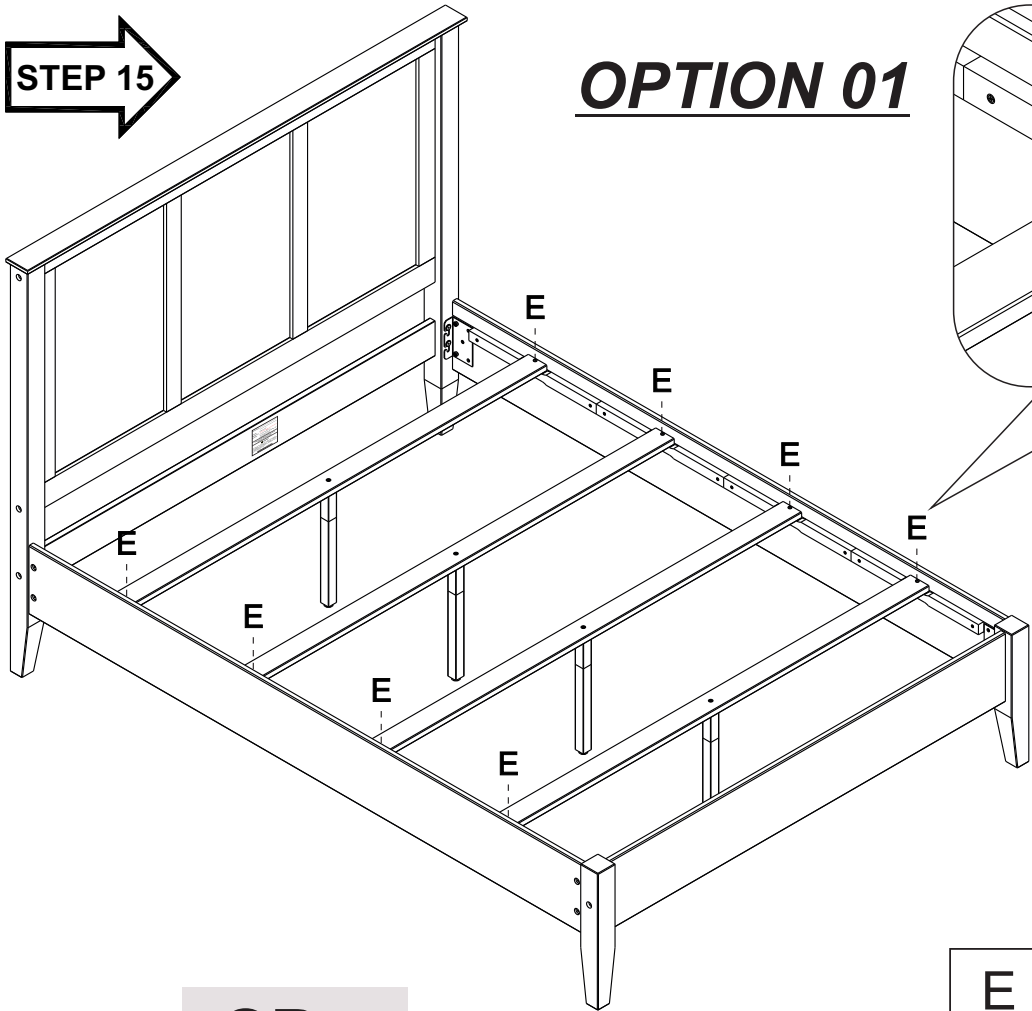

8x

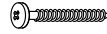
E		Ø4,5 x 35 mm	08
---	---	--------------	----

OR...

STEP 16

OPTION 02

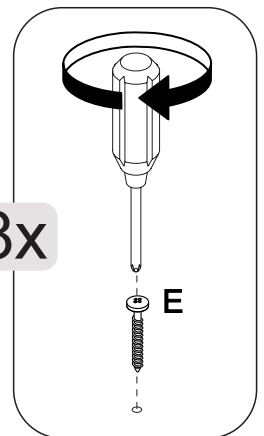
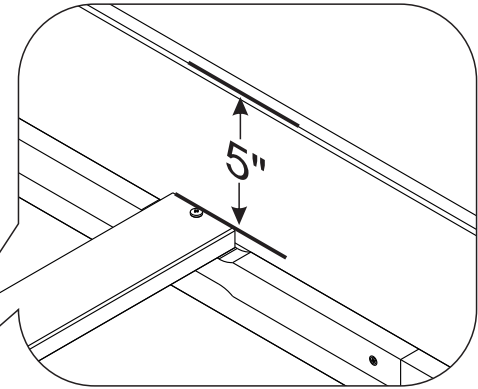
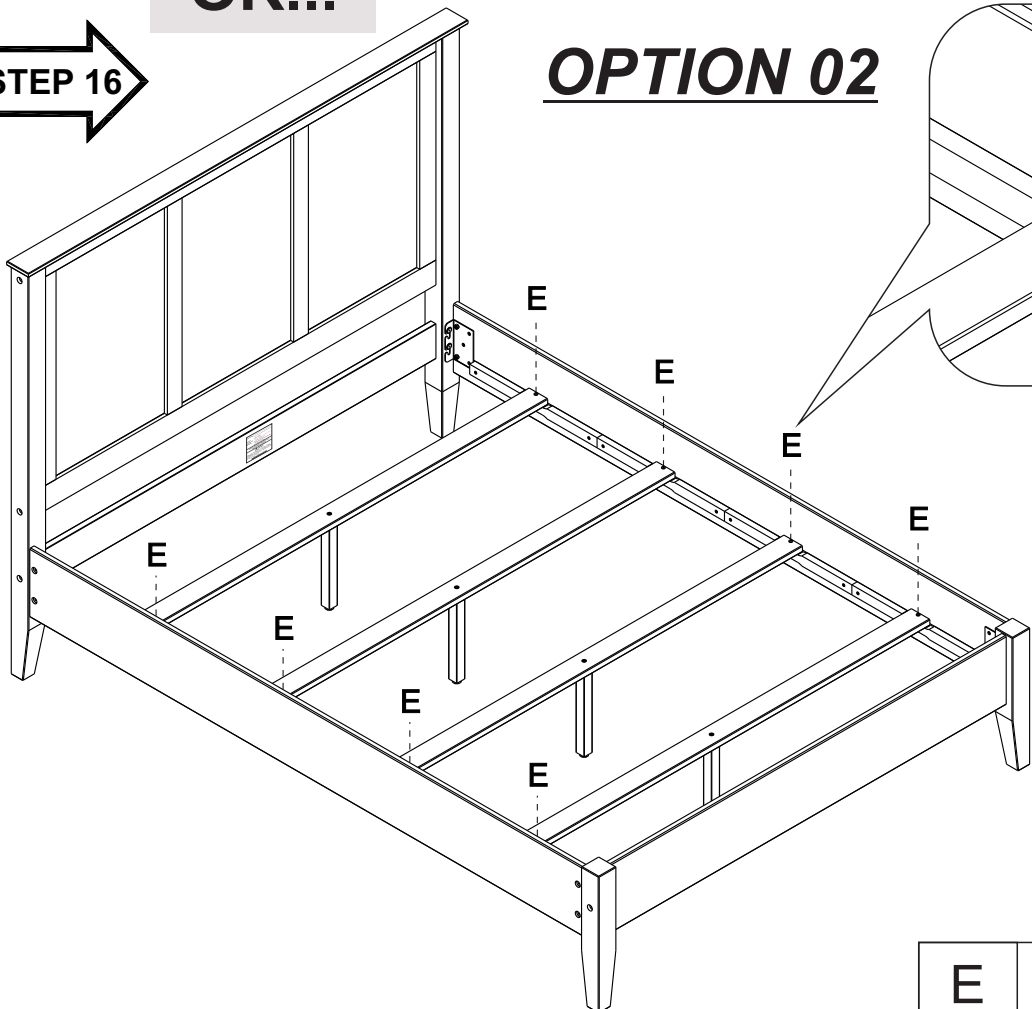

8x

E		Ø4,5 x 35 mm	08
---	---	--------------	----

STEP 17

OPTION 01

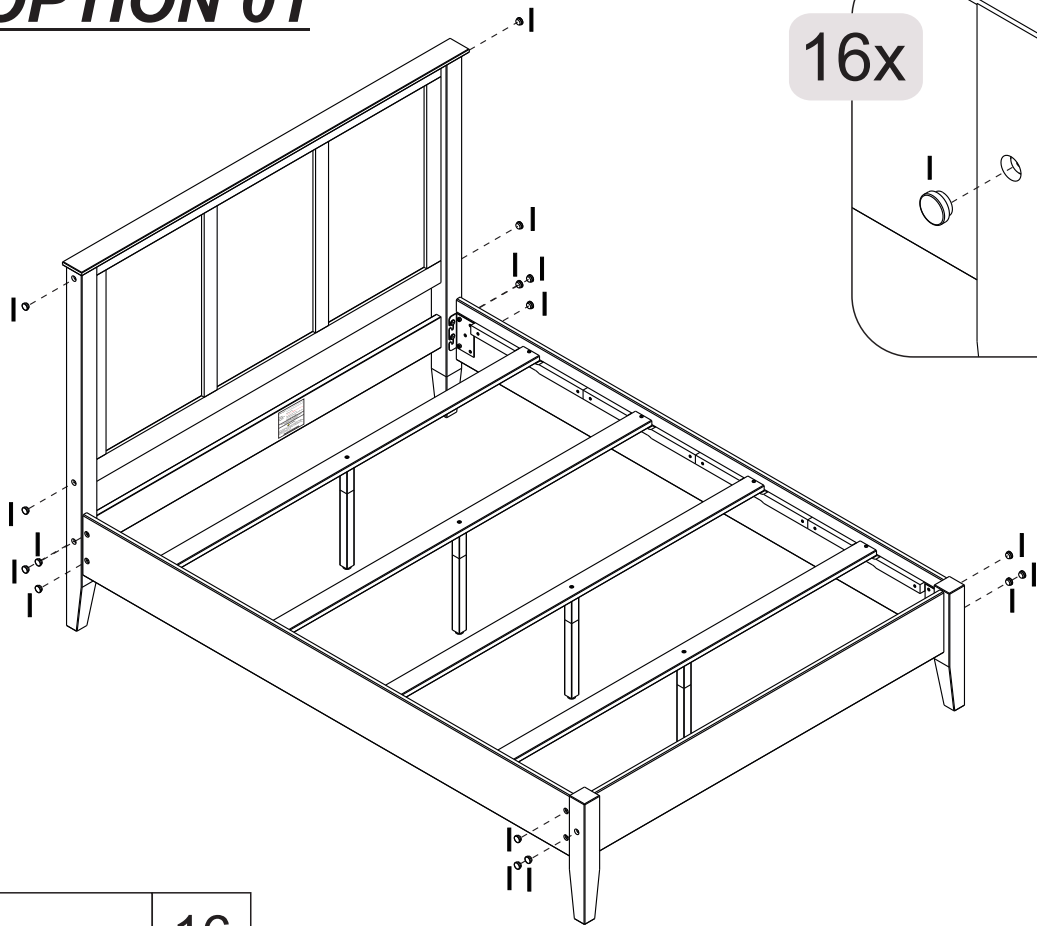

16x

I		16
---	---	----

OR...

STEP 18

OPTION 02

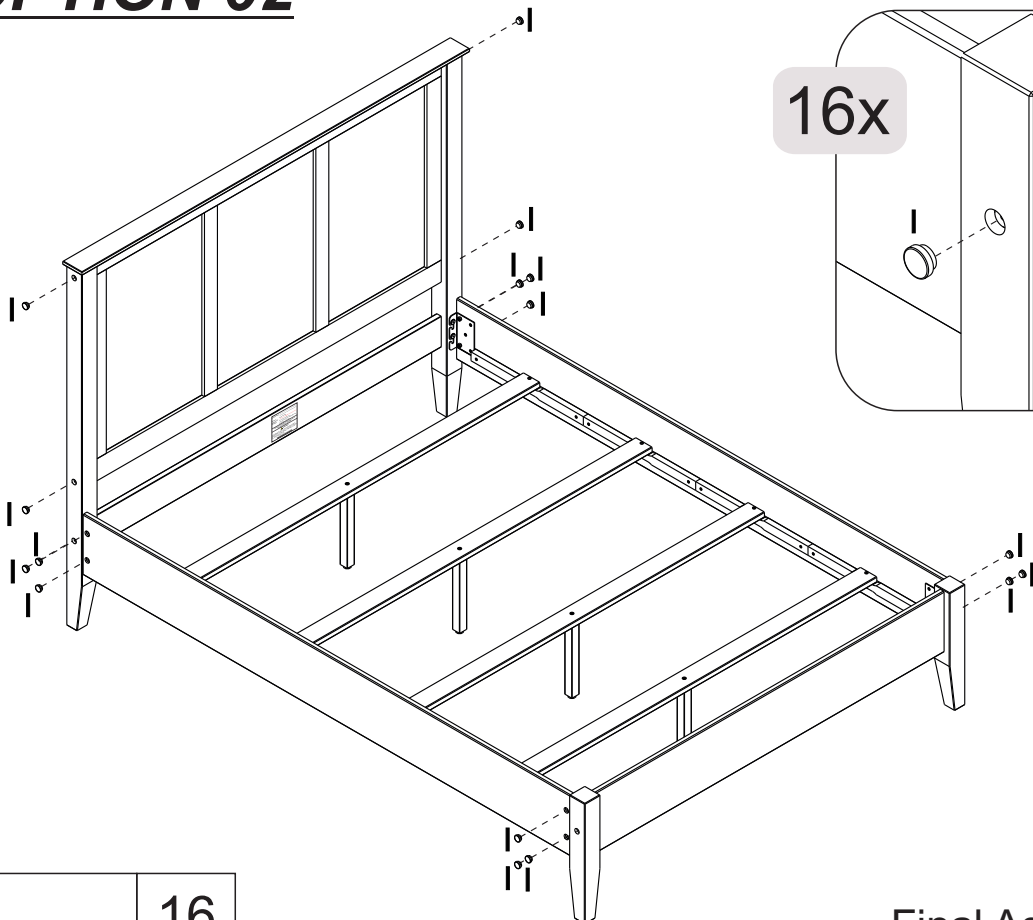

16x

I		16
---	---	----