



PRODUCT SPECIFICATION
产品说明书

DOC NO.: RD-SL402058-02857

REV. : A/1

SHEET : 1 of 11

Specification Approval Sheet

规格承认书

Customer 客户: 三本

SUNLY Model name 型号: SL402058-500mAh

SUNLY P/N 电池料号: /

Cell P/N 电芯料号: /

Issuing Date 承认日期: 2019-12-26

Customer Approved 客户确认	Customer Stamp 客户签章
Date 日期:	

Prepared by/Date 制定/日期	Approved by/Date 核准/日期
杨聪聪	汤大明



PRODUCT SPECIFICATION
产品说明书

DOC NO.: RD-SL402058-02857

REV. : A/1

SHEET : 3 of 11

CONTENTS

1. Scope 范围.....	4
2. Model 型号:SL402058.....	4
3. Specification 规格说明.....	4
4. Safety Performance 安全性能.....	5
5. Temperature applicability 温度适应性.....	5
6. ESD 静电释放.....	5
7. Cell Safety Criteria for Acceptance 电芯安全标准.....	6
8. Warranty and product liability 产品保证与责任	7
9. Caution 警告.....	7
10. Shipping Drawing 出货图样.....	8
11. Pack part list 包装物料单.....	8
12. PCM Specification 保护板规格.....	9
13. Charge-discharge diagram 充放电曲线图.....	10



PRODUCT SPECIFICATION
产品说明书

DOC NO.: RD-SL402058-02857

REV. : A/1

SHEET : 4 of 11

1. Scope范围:

This document describes the Product Specification of the Lithium-ion Polymer rechargeable battery SL402058 supplied by Dongguan SUNLY Battery Technology Co., Ltd.

本规格书描述了由东莞山锂电池生产的聚合物锂离子电池的产品性能。

2. Model型号: SL402058

3. Specification规格

No.	Items 项目	Specifications 规格	
3.1	Appearance 外观	The surface is clear and no scratch,no mechanical,match well with the main machine 表面干净无机械性刮伤	
3.2	Charge voltage 充电电压	4.25V	
3.3	Nominal voltage 标称电压	3.7V	
3.4	Typical capacity 典型容量	520mAh	
3.5	Minimum capacity 最小容量	500mAh (0.2C discharge)	
3.6	Energy density 能量密度	398.7Wh/L	
3.7	Standard Charge(25±2℃) 标准充电	Constant current 0.2C mA to 4.25V , 0.2C恒流充电至4.25V Constant voltage 4.25V 0.02CmA cut-off 恒压充电至0.02C截止	
3.8	Fast charge(25±2℃) 快速充电	Constant current 1.0C mA to 4.25V 1.0C恒流充电至4.25V Constant voltage4.25V, 0.02CmA cut-off 恒压充电至 0.02C 截止	
3.9	Standard Discharge (25±2℃) 标准放电	Constant current 0.2CmA 2.8V Cut-off 0.2C 恒流放电至 2.8V	
3.10	Fast Discharge(25±2℃) 快速放电	Constant current 1.0CmA 2.8V Cut-off 1.0C 恒流放电至 2.8V	
3.11	Operating temperature 工作温度	Charging 充电: 0℃ ~ 9℃ 0.2CmA/4.25V,0.02CmA cut-off 10℃~45℃ 1.0CmA/4.25V,0.02CmA cut-off Discharging 放电: -20℃ ~ 60℃ 1.0CmA/2.8V	
3.12	Storage (At 50% SOC and specified temp, recoverable capacity in % vs time.) 储存(在50%的带电量下,可恢复容量与时间的特性)	-20℃~25℃	(12 months, ≥85%)
		-20℃ ~35℃	(3 months, ≥85%)
		-20℃ ~45℃	(1 month, ≥90%)
		-20℃~60℃	(1 month, ≥80%)
		20±5℃ is the recommended storage temperature 20±5℃为我司推荐的储存温度	
3.13	Cycle Life 循环寿命	500 cycles, more than 80% at std charge / std discharge(25±2℃) 500次大于 80%	
3.14	Impedance 内阻	≤500mΩ	
3.15	Pack weight 成品重量	Approx:12.0g	
3.16	Delivery voltage 出货电压	3.80-3.95V	
3.17	Warranty Time 保质期	12 Month	
3.18	Environmental requirements 环境要求	directive 2006/66/EC and its article 4 amendment of directive 2013/56/EU、Reach	



PRODUCT SPECIFICATION
产品说明书

DOC NO.: RD-SL402058-02857

REV. : A/1

SHEET : 5 of 11

4. Safety Protection Performance 安全保护性能

No.	Items 项目	Test Method and Condition 测量方法与条件	Criteria 判定标准
4.1	Over-Charge Protection 过充性能	At 20±5°C conditions , after fast-charging, use an external 5V power to charge the battery and last for 24 hours, then check the appearance of battery. 20±5°C条件下, 快速充电至 5V 并保持 24h, 检查电池的外观	The appearance is normal, no explosion, no fire, no smoking, no leakage. 外观正常, 不爆炸, 不起火, 不冒烟, 不漏液
4.2	Over-Discharge Protection 过放性能	At 20±5°C conditions, discharge battery to 2.5V with 0.2C constant current, then discharge with 30Ω loading for 24 hours. Check the appearance of battery. 20±5°C条件下, 以 0.2C 恒流放电至 2.5V, 保持 24h, 检查电池的外观	The appearance is normal, no explosion, no fire, no smoking, no leakage. 外观正常, 不爆炸, 不起火, 不冒烟, 不漏液
4.3	Short-Circuit Protection 短路性能	After fast-charging, use a cable of 0.1Ω resistance to short the battery for 24 hour. Then check the appearance of battery. 快速充电后, 外接 0.1Ω 电阻短路 24h, 检查电池的外观 Cut circuit of resistance test the battery's voltage after charging with 1C constant current for 5 seconds. 切断外接电阻后, 测试电压后以 1C 恒流充电 5s	The appearance is normal, no explosion, no fire, no smoking, no leakage. 外观正常, 不爆炸, 不起火, 不冒烟, 不漏液

5. Temperature Applicability(温度特性)

5.1. Discharge Performance at High Temperature 高温下放电特性

At 55±2°C conditions, keep the battery for 2hrs, discharge the battery to 2.8V with 0.2C constant current, After keep the battery 2hrs at 20±5°C, then check the appearance of battery. The discharge capacity is above 80% of original capacity. The appearance is no distortion, no explosion, no leakage.

在 55±2°C 条件下保持 2h, 以 0.2C 放电至 2.8V 后, 在 20±5°C 保持 2h, 检查电池外观。充 80% 的容量, 电池不变形, 不爆炸, 不漏液。

5.2 Discharge Performance at Low Temperature 低温下放电特性

At -10±2 °C conditions, keep the battery for 2hrs, discharge the battery to 2.8V with 0.2C constant current, After keep the battery 2hrs at 20±5°C, then check the appearance of battery. The discharge capacity is above 85% of original capacity. The appearance is no distortion, no explosion, no leakage.

在 -10±2 °C 条件下保持 2 h, 以 0.2C 放电至 2.8V 后, 在 20±5°C 保持 2 h, 检查电池外观。充 85% 的容量, 电池不变形, 不爆炸, 不漏液

6. ESD(静电释放)

At direct discharge against the pins with ±4kv and over the housing with ±8kv.

在 ±4kv 的针脚或 ±8kv 外罩下放电

No damages are allowed. 不允许有损害



PRODUCT SPECIFICATION
产品说明书

DOC NO.: RD-SL402058-02857

REV. : A/1

SHEET : 6 of 11

7. Cell Safety Criteria for Acceptance 电芯安全接受标准

Item 项目	State 状态	Test method 测试方式	Specification规格
External Short-circuit Test 外部短路测试	Fully Charged 满充	Cell terminals are short-circuited to discharged state less than 0.1V or longer time with a resistance of 50mΩ or less. Tests are to be conducted at room temperature. 在常温测试条件下，在电芯极耳用50mΩ的电阻进行长时间的短路，直至电压低于0.1V	NO EXPLOSION AND NO FIRE. 不爆炸，不起火
Heating Test 热测试	Fully Charged 满充	The temperature of the oven is to be raised at a rate of 5±2℃/min. to a temperature of 130±2℃, and remains for 30 minutes at this temperature. 在烤箱中以5±2℃/min的加热速率至温度达到130±2℃，保持30分钟	NO EXPLOSION AND NO FIRE. 不爆炸，不起火
Crush Test 挤压测试	Fully Charged 满充	Crush between two flat plates. Applied force is about 13kN. 在两块平板之间用13kN力进行挤压，	NO EXPLOSION AND NO FIRE. 不爆炸，不起火
Impact Test 重物冲击	Fully Charged 满充	Impact between bar (15.8mm diameter) and 9 Kg falling material (at a height of 50 cm). Bar is laid across the center of the test sample. 将直径为15.8mm的铁棒放在电芯，9Kg的重物从50cm高度下落，铁棒穿过样品的中心位置	NO EXPLOSION AND NO FIRE. 不爆炸，不起火
Drop Test 跌落测试	Fully Charged 满充	Drop a fully charged cell onto a concrete floor from the height of 1.0 meters for 2 times. 满充后的电芯每个面从1m高处自由落下2次	NO EXPLOSION AND NO FIRE. 不爆炸，不起火
Vibration Test 振动测试	Fully Charged 满充	Vibrate the cell in tri-axial directions each for 90~100 min. in conditions of 10~55 Hz with amplitude 0.8 mm. 以10~55Hz的频率、振幅0.8mm，电芯在三维方向振动90~100min	NO EXPLOSION DEFORMATION AND NO FIRE 不爆炸变形，不起火
Nail Test 针刺	Fully Charged 满充	The battery is fully charged in standard charging condition, Standby for 2 hour, a nail is penetrated vertically through the center of the cell (The diameter of the nail is 3.0mm.) 电池满充电后，用一根直径为3.0mm 的铁针垂直刺穿电芯	NO EXPLOSION AND NO FIRE. 不爆炸，不起火
K value Test K值测试	3.92±0.1V	25 °C environment, constant current constant voltage charging 0.2C to 3.92±0.1V cut-off current 0.01C, the normal temperature 25°C for 96h, the high temperature 45°C for 72h 。 25℃环境下，以0.2C恒流恒压充电至3.92±0.1V截止电流0.01C，常温25℃搁置96h，高温45℃搁置72h	Voltage drop 10mV or less 电压下降≤10mV



**PRODUCT
SPECIFICATION**
产品说明书

DOC NO.: RD-SL402058-02857

REV. : A/1

SHEET : 7 of 11

8.0 Warranty and product liability 产品保证与责任

Warranty period of this product is 12months from delivery date.保质期为出货后的 12 个月

(when the customer using it in the host, need charge it as bellow 8.13 requirement)当客户使用后, 需遵循 8.13 的要求

You are kindly requested to use the battery, which is delivered from DG SUNLY battery Technology Co., Ltd. in strict accordance with the specification, and remarks include at the end of the document. Due to improper usage of the battery, an accident or a fire may occur due to the battery generating heat, catching fire or rupture, smoke.

SUNLY will not guarantee against any accidents occurring due outside those written in this specification.

您必须严格遵守东莞山锂电池科技有限公司规格书和文件后面的注释使用电池, 由于误用会引起电池过热, 发生火灾或爆炸。对于没有按照规格书进行操作所造成的任何事故, 东莞山锂电池科技有限公司不承担任何责任。

9.0 Caution!警告

In order to prevent the battery possibly occurs leaks, over heat, swollen, please note the preventive measure.

为避免电池出现漏液, 过热, 鼓胀, 请注意以下事项

Handling Precautions and Guideline:操作方法与原则

- 9.1 When charge please select the lithium-polymer battery special battery charger.请使用锂离子电池专用充电器
- 9.2 Strictly prohibits inverting the cathode use battery. 严禁颠倒正负极使用电池。
- 9.3 Strictly prohibits directly connect battery to power source plug 严禁将电池直接接入电源插座
- 9.4 Please do not throw the battery to water or put into heater 禁止将电池丢于火或加热器中。
- 9.5 Strictly prohibits plunging the battery in sea water or water, when battery do not use, please store battery in the cool-dry environment. 严禁将电池浸入海水或水中, 保存不用时, 应放置于阴凉干燥的环境中。
- 9.6 The prohibition in strong static electricity and strong magnetic field place use, otherwise is easy to destroy the battery PCBA. 禁止在强静电和强磁场的地方使用, 否则易破坏电池安全保护装置, 带来不安全的隐患。
- 9.7 The prohibition puts the battery nearby the hot high temperature source, like the fire, the heater and so on use and leaves alone 禁止将电池在热高温源旁, 如火、加热器等使用和留置。
- 9.8 The prohibition directly connects the battery cathode with the metal to short-circuit. 禁止用金属直接连接电池正负极短路
- 9.9 The prohibition rap or throws, steps on the battery and so on 。禁止敲击或抛掷、踩踏电池等
- 9.10 Forbids directly to weld the battery and pierces the battery with the nail or other sharp weapons 。禁止将电池与金属, 如发夹、项链等一起运输或贮存
- 9.11 If the battery sends out the unusual smell, gives off heat, the distortion or appears any exceptionally, immediately moves the battery from the installment or the battery charger to and stops using 。如果电池发出异味、发热、变色、变形或使用、贮存, 充电过程中出现任何异常, 立即将电池从装置或充电器中移离并停用
- 9.12 If the battery occurs leaks, the electrolyte enters eye, please do not have to rub scratches, the application clear water flushing eye, and delivers the medical treatment otherwise to be able immediately to injure the eye 。如电池泄露, 电解液进入眼睛, 请不要揉擦, 用清水冲洗眼睛, 立即送医治疗, 否则会伤害眼睛
- 9.13 When battery long-term storage, or assembly in the host, suggest customer should take every 6months carry on one time charge and discharge and recharge it to half-charge state (3.7-3.9V)(the method: 0.2CmA charge and discharge).当电池长时间不使用时, 建议每 6 个月对电池进行一次充放电, 并充电至半电 (3.7V~3.9)
- 9.14 Abandon the battery to wrap up the electrode using the insulating paper, prevented the battery short-circuits. 废弃之废弃电池应用绝缘纸包住电极
- 9.15 Do not decompose the battery.禁止拆解电池



PRODUCT SPECIFICATION
产品说明书

DOC NO.: RD-SL402058-02857

REV. : A/1

SHEET : 8 of 11

10. Shipping Drawing 成品图纸

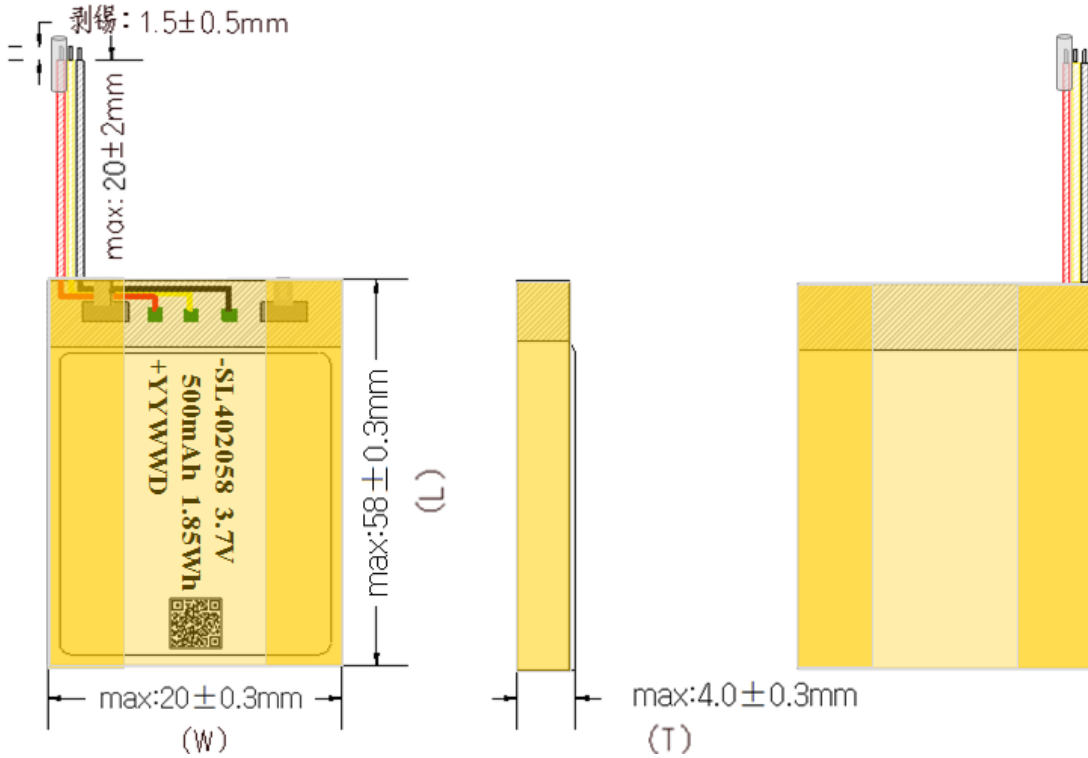

QR code: ABCDEFGHIJKL
 ABC: MI code 工艺文件编号
 D: Year 年
 EF: Week 周
 G: Day 星期
 HIJKL: Serial number 流水号

11. Pack parts list 物料清单

No	Name	Type or Specification	Qty	Unit	Remark
11.1	Cell	SL402058-500mAh 3.7V	1	PCS	
11.2	Capacity	SMD-0402/0.1uF-20%/+80% 16V	1	PCS	
11.3	Resistance	SMD-0603/330Ω±5%	1	PCS	
11.4	Resistance	SMD-0603/470Ω±5%	1	PCS	
11.5	MOSFET	TSSOP-6/8205	1	PCS	
11.6	NTC	SMD-0402/10kΩ±5%,B=3435	1	PCS	
11.7	IC	SOT-23-6/S8261-DAA	1	PCS	
11.8	PTC	SMD1206P075TF	1	PCS	
11.9	PCB	JZX-1838	1	PCS	
12.0	Wire	UL3302 28#(red,yellow,black)	3	PCS	



PRODUCT SPECIFICATION
产品说明书

DOC NO.: RD-SL402058-02857

REV. : A/1

SHEET : 9 of 11

12. PCM Specification 保护板规格

12.1 Scope 范围

The specification is applied to the protection of lithium-ion battery from overcharge、over discharge、over current and short-circuit.

此规格书适用于锂离子电池的过充、过放、短路保护功能

12.2 Model 型号: **SL402058**

12.3 Main organ 主要元件:

IC:S8261-DAA

MOSFET : 8205

12.4 Application Circuit 线路板原理图

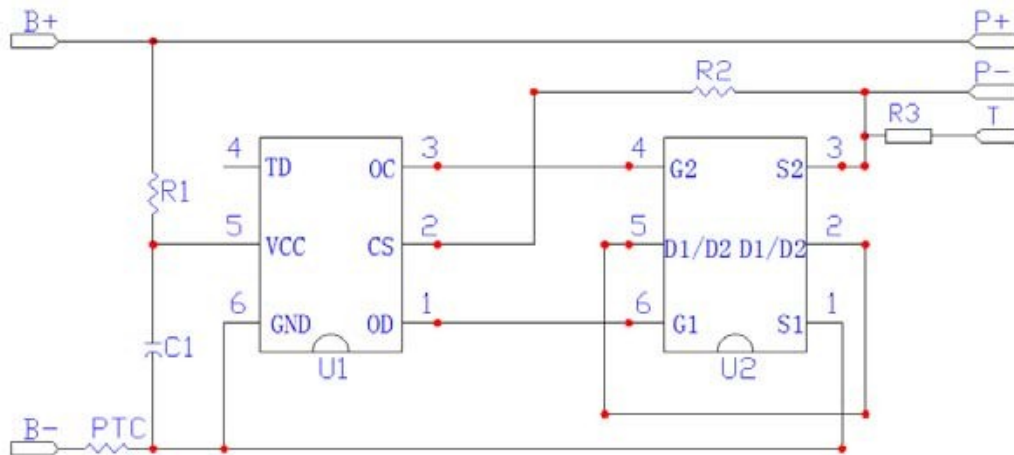

12.5 PCB Layout 布局图

Top Layer



Bottom Layer

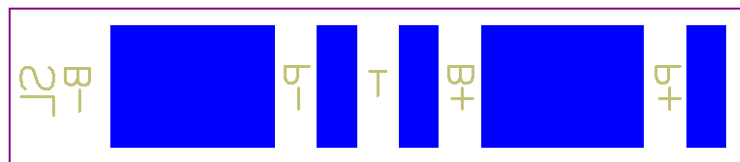

12.6 Pad description and parts location diagram: 焊点说明

Item 项目	Description 描述	Item 项目	Description 描述
P+	Battery pack positive terminal 电池正极端子	P-	Battery pack negative terminal 电池负极端子
B+	Connect to cell positive 连接电芯正极	B-	Connect to cell negative 连接电芯负极
T	Battery pack NTC terminal NTC 引线		



PRODUCT SPECIFICATION
产品说明书

DOC NO.: RD-SL402058-02857

REV. : A/1

SHEET : 10 of 11

12.7 Electricity parameter (Environment temperature 25°C) 电性能参数：

Item 项目	Name 名称	Term	Min	Typical	Max	Units
Voltage 电压	Over charge detection voltage 过充保护截止电压		4.255	4.28	4.305	V
	Overcharge detection delay time 过充保护延迟时间		/	/	1000	mS
	Over charge release voltage 过充保护恢复电压		4.055	4.08	4.105	V
	Over discharge detection voltage 过放保护截止电压		2.95	3.0	3.05	V
	Over discharge detection delay time 过放保护延迟时间		/	/	128	mS
	Over discharge release voltage 过放保护恢复电压		2.9	3.0	3.1	V
Current 电流	Operation of current consumption 静态电流		/	/	7	μA
	Over discharge current detection 放电过流保护电流		1.0	/	3.0	A
	Over discharge current detection delay time 放电过流保护时间		5	/	20	mS
	Short circuit protection 短路保护		OK			
	Short circuiting detection delay time 短路保护延迟时间		220	400	400	us
NTC 热敏电阻		10K				
ID 编号		/				
0V battery charge function 0V 电池充电功能		Available 适用				
Resistance 电阻	PCB Resistance 保护板电阻		≤400			mΩ

13、Charge-discharge diagram 充放电曲线图

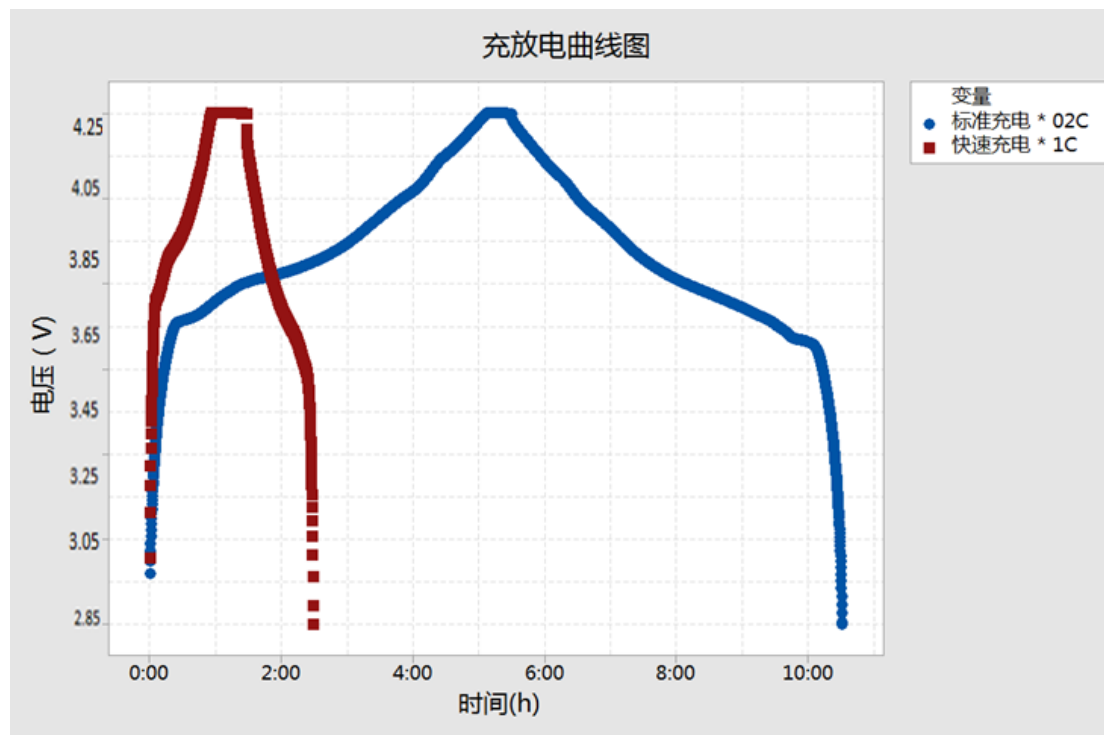



14、Battery pack packaging requirements / 电池组的包装要求.

Figure, size, color flag comply with GP/T 191-2000 requirements. Or according to SUNLY standard.

标志的图形、尺寸、颜色符合 GP/T 191-2000 的要求。或按照山锂电池科技有限公司标准执行。

Any matters that this specification doesn't cover should be conferred between the customer and SUNLY.

任何本规格书中未提及的事项，需要经双方协商确定，如下图：

