



Jafanda LLC.

1309 Coffeen Avenue STE 4304
Sheridan, Wyoming 82801
support@jafanda.com

EPA Est.NO.98581-CHN-1
Made In China



JAFANDA

JF999 Air Purifier User Manual

READ AND SAVE THESE INSTRUCTIONS

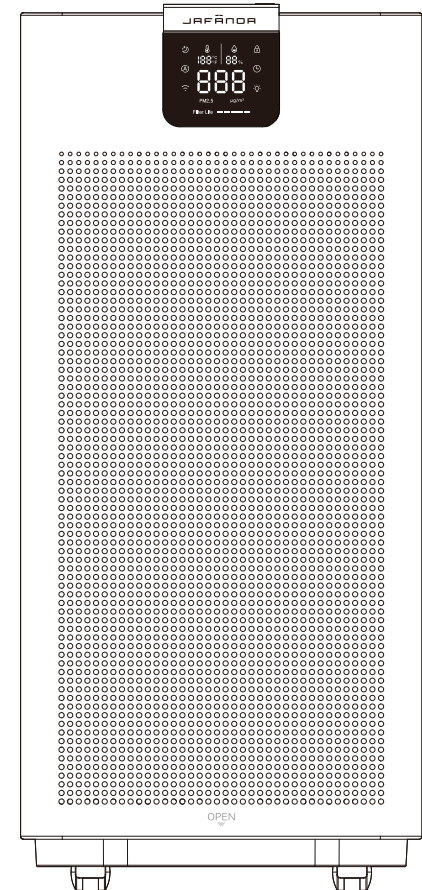

THANK YOU FOR YOUR PURCHASE!

Contact our support team by Email:
support@jafanda.com

Join the jafanda Community on Social Media



@JAFANDA.COM



TABLE OF CONTENTS

Packing Contents	1
Specifications	1
Safety Instructions	2
Know Your Air Purifier	3
Control Panel	4
Product Features	5
Using Your Air Purifier	6-7
Operating Instructions	8
PM Sensor Replacement	9
Cleaning and Maintenance	10
Filter Replacement	11
Troubleshoot Guide	12
Warranty & Support	12
Returns & Refunds	12

Packing Contents

Packing Contents

JF999 Air purifier	1 set
Composite filter	2 pieces (Preinstalled)
Power Cord	1 (in the accessories box)
User Manual	1 (in the accessories box)



Specifications





Product specifications

Product Name	Air Purifier	Model	JF999
Rated Voltage	120V~	Product Size	13.0 x 11.81x 28.03 in /33.0x 30.0 x71.2cm
Rated Frequency	60Hz		
Rated Current	1.4A	Package Size	16.3 x 15.08x 31.93 in /41.4x 38.3 x81.1cm
Rated Power	110W	N.W	27.1lb/12.3kg
CADR (Clean Air Delivery Rate)	588CFM(1000m ³ /h)	G.W	32.61lb/14.8kg
Noise Level	22-58dB	Standby Power	< 2W
Operating Conditions	Temperature: 14°F -104°F / -10°C -40°C Humidity : 20%-95% RH	Filter Life	3000H
		Recommended Room Size	915ft ³ (5 Times/h) 2288ft ³ (2 Times/h) 4575ft ³ (1 Times/h)

Safety Instruction

The following safety precautions and instructions must be read carefully and observed when the product is used!

 Prohibitory sign	The behaviors with this sign must be prohibited, otherwise it may cause product damage or endanger the user's personal safety.
 Warning sign	The behaviors with this sign must be operated in strict accordance with the requirements, otherwise it may cause product damage or endanger the user's personal safety.
 Attention sign	The behaviors with this sign must be paid attention to, otherwise it may cause product damage or other losses due to improper operation.

	Please do not touch the power plug with wet hands.		Please regularly clean the machine and power plug.
	Please do not block the air inlet/outlet.		Only the 120V power sockets are 120V power sockets.
	Please do not use the machine in any place with much oil fume or high humidity.		Please do not put it close to or on any heat source (such as a fireplace, stove or a place with flammable gases).
	Please do not rinse the high-efficiency composite filter with water.		Please be careful when cleaning the air purifier, as corrosive detergents may damage the surface.
	This machine shall not be used by people with disabilities, perceptual disturbance or dysgnosia or children alone, unless they use it under the supervision and guidance of safety director on the site.		Please do not unplug the power cord from the power socket when cleaning the air purifier or leaving it unused. Otherwise, it may cause electric shock due to poor insulation or fire due to short circuit.
	Contains FCC ID: 2ANDL-WBR3 This device complies with part 15 of the FCC Rules. Operation is subject to the following two conditions: (1) This device may not cause harmful interference, (2) this device must accept any interference received, including interference that may cause undesired operation.		
This air purifier is suitable for floor standing. With caster wheels, it's easy to move in-house. Do not place the air purifier closer than 10cm/4" to wall or another object.			

KNOW YOUR AIR PURIFIER

Structure and Name of Product Components

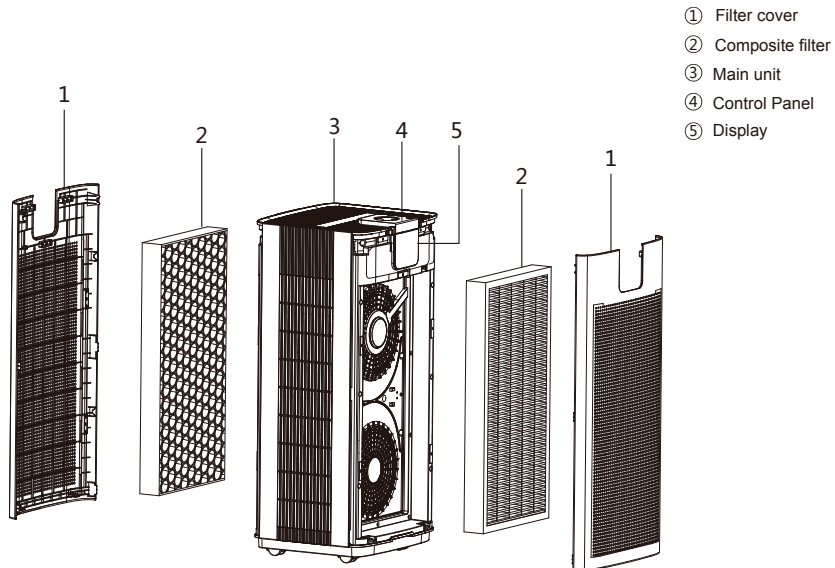

If the picture is inconsistent with the actual product, the latter shall prevail.

Display

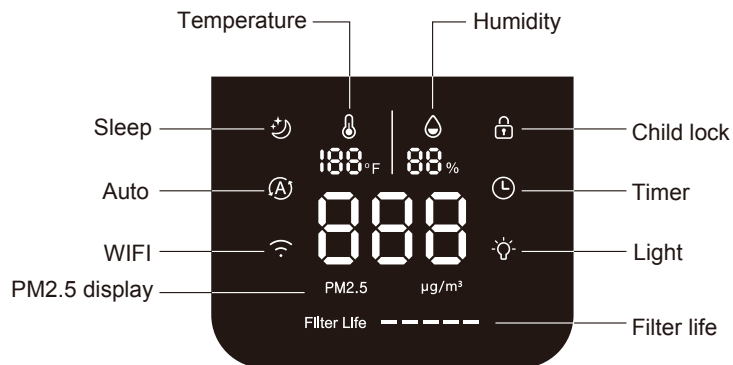

Control Panel

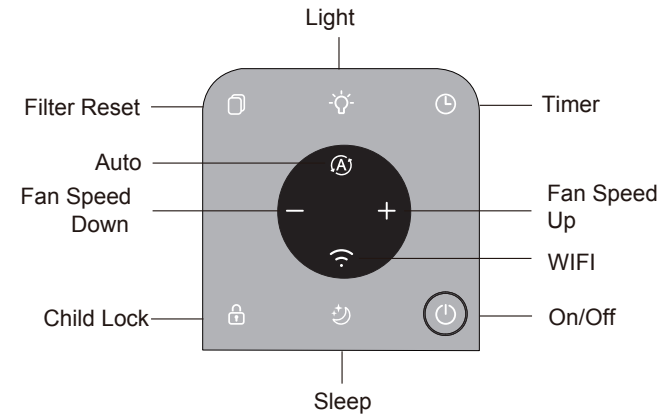

Icons	Icons Name	Introduction
	On/Off	Turns the Air Purifier ON or OFF.
	Fan Speed	Fan speed cycles through 1-5 settings.
	Filter Reset	The filter needs to be changed when the icon lights up in red.
	Light	Press dimmer to adjust the lighting mode of the ambient light.
	WIFI	Press WIFI button to connect it to WIFI.
	Auto	In Auto mode, fan speed will be adjusted automatically based on the real-time PM2.5 density.
	Timer	Set the timer to switch on and off the air purifier automatically. The timer is available from 1 to 12 hours, stopping operation when the selected time has elapsed.
	Sleep	Press the sleep button in the working state to enter the sleep mode.
	Child Lock	All the other buttons on the control panel are not responsive when the child lock is on.

Product Features

Integration of Multiple Functions

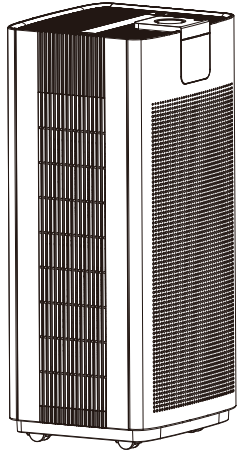

- Efficiently purify PM2.5, smoke, pollen, dust and other particulate pollutants
- 5 fan speeds
- Timer (0-12H)
- Filter replacement indicator
- Manual, Auto, Sleep and other operating modes
- Real-time monitoring of indoor temperature and humidity
- Child lock
- Real-time value display of PM2.5
- WiFi control

3-Stage Filtration

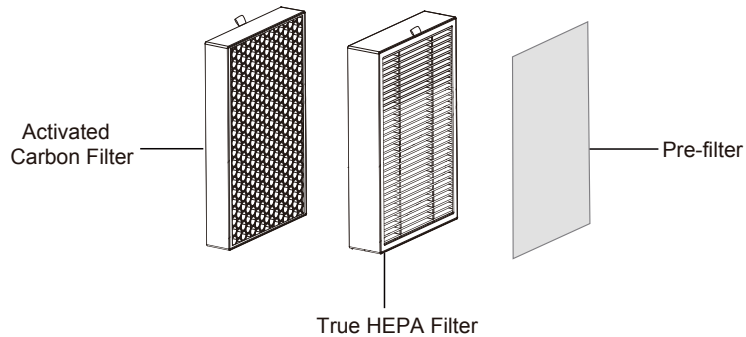

Pre-filter

Captures larger particles such as human hair, fibers, pet fur, and dust particles; Protects the HEPA filter and extends its life.

True HEPA filter

Removes at least 99.97% of airborne particles 0.3 micrometers (μm) in diameter, Captures particles as small as 0.015 micrometers (μm), Filters small particles such as PM2.5, smoke, pollen, dust, and other pollutants.

Activated Carbon Filter

Absorbs and eliminates fumes and volatile organic compounds in the air.

[Note] The activated carbon filter, True HEPA filter and Pre-filter are combined in the same filter.

Using Your Air Purifier

- ⚠ Precautions for Use**
- All filters are attached in the air purifier.
 - Please ensure that the filter is installed correctly before use.

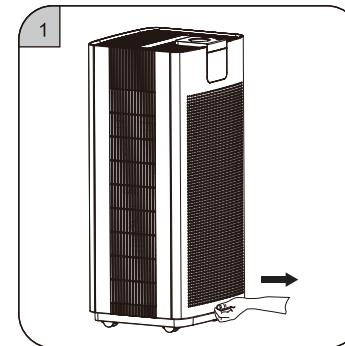

① Pull the filter cover out slightly.

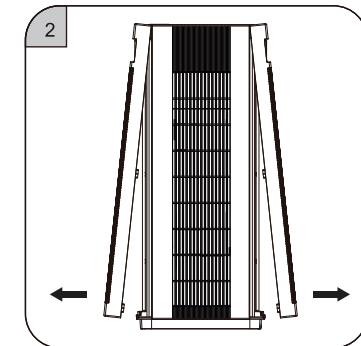

② Take out the filter cover.

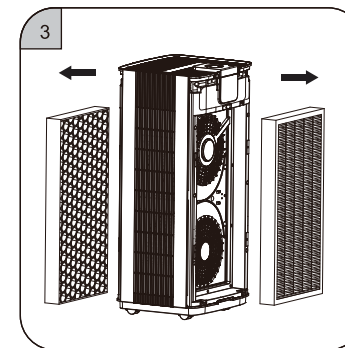

③ Take out the new filter with plastic film of the machine inside.

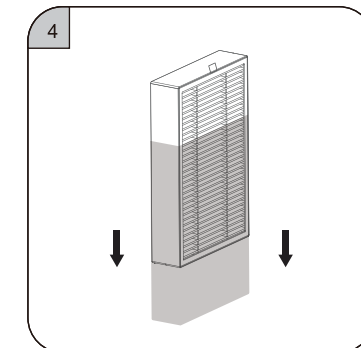

④ Remove the plastic film on the filter.

Using Your Air Purifier

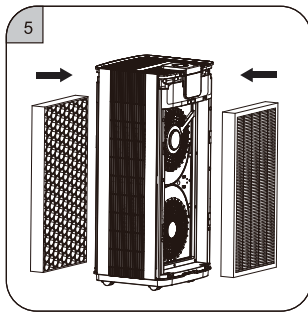

⑤ Put the filter without plastic film back into the machine.

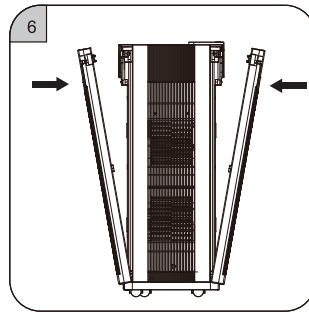

⑥ Put the filter mesh cover back.

Getting Started

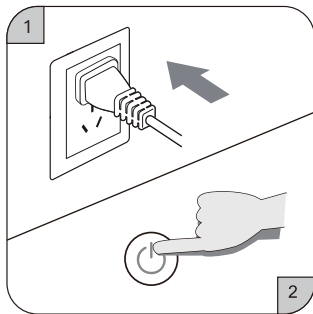

① Insert the power plug to make the machine powered on, and the buzzer makes a "ding" sound.
② Power on by touching the power key.

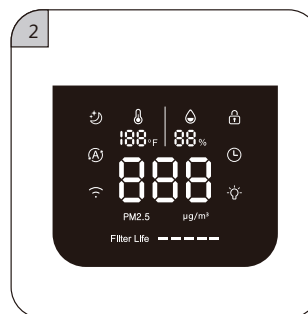

③ The display screen lights up and touch a relevant function button to enter the working state.

Operating Instruction



On/off button

Touch the button "⏻" in the standby state to enter the working state; touch the key "⏻" in the working state to enter the standby state. The power key indicator lights up in red in the standby state and white in the working state.



Sleep button

Touch the button "🌙" in the working state to enter the sleep mode. In the sleep mode, all indicator lights and icons light off except for the "🌙" indicator light and sleep icon. The wind speed remains at Gear 1, and the sleep button indicator light and icon will light off in 10 seconds. The air purifier will be awakened in the sleep mode by touching any function key once. The sleep button indicator light and icon will light up when it returns to the sleep mode. Exit the sleep mode and return to the pre-sleep setting mode by touching "🌙" button once again.



Light button

Touch "💡" to adjust the light brightness. Each touch will change the ambient light mode. 5 modes to choose:
1. 25% brightness
2. 50% brightness
3. 100% brightness
4. shut off button, display screen and ambient light. 10s later, the sleep icon light off
5. lit button and display screen, ambient light stays off
When the touch panel is completely black, press any key to wake up "💡"

Memory function

Restart the device in the power-up state every time, the machine will remember the previous wind speed and light settings. However, after the adapter is re-plugged, everything will return to the default state. The machine runs at Gear 1 by default after startup, and the ambient light will be slowly on and then go out.



WiFi button

When the machine is powered on and enters the standby state, the WiFi button and icon flash for network connection. The WiFi button and icon will be constantly on when network is connected but go out if network connection fails within 10 minutes. When the WiFi button and icon go out in the power-on state, press and hold the WiFi button for 3 seconds to connect the network. The prompt tone "ding ding ding" will be heard, and the WiFi button and icon flash for network connection. The WiFi icon flashes in the process of network connection and keeps constantly on when the network is successfully connected. The icon will go out when the network fails to be successfully connected within 10 minutes.



Fan speed button

Touch the fan speed button + in the working state to increase the fan speed, and touch the fan speed button - to decrease the fan speed. The white indicator light of the fan speed key is on. Each touch of the button will change the gear from 1 to 5 successively and circularly. When the fan speed is adjusted, the fan speed gear is displayed in the comprehensive display area.



Timer button

Press "🕒", the timer button light will turn ON to set the timer. The screen will display the timer's set time. Each touch will increase the timer by 1 hour, the value range is 0-12. When the value is 0, the timing can be canceled. Release the button and after 3 seconds the timer will be set. The timer will then start counting down. Press "🕒" in the working state to set timed shutdown; Press "🕒" in the standby state to set timed start



Child lock button

This button aims to avoid misoperation by children or pets in an unattended condition. In the working state, press and hold the button "🔒" (for more than 3s) to switch the on/off state of child lock. When the child lock is on, the child lock key indicator and icon on the display screen light up. Other function button become invalid when the child lock is on. When the child lock is off, the child lock key indicator lights up.



Auto button

Touch the button "🔄" in the working state to enter the auto mode, the auto button is fully on. The wind speed of the machine changes with the PM2.5 concentration value, and the wind speed gear is switched from 1 to 4 automatically. The color of the air quality indicator also changes with the PM2.5 concentration value (the corresponding relation is shown in the following figure).

Long press the "🌡️" for 5 seconds to switch the temperature display between Fahrenheit Celsius and warm Celsius.

PM2.5 value	Air quality	PM2.5 air quality indicator	Wind speed gear
0-12	Excellent	Green	1
13-35	Good	Blue	2
36-55	Poor	Yellow	3
>55	Severe	Red	4

PM2.5 Sensor Replacement

Replacement of Sensors (Please do not operate by yourself because the sensors must be replaced by professional maintenance personnel)

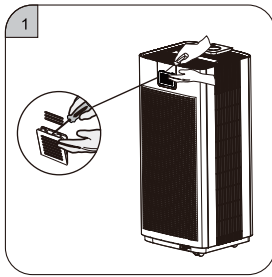

- ① Open the sensor cover with a straight screwdriver.

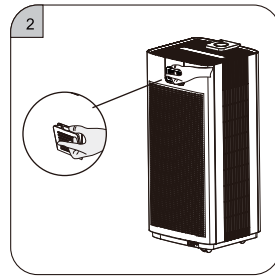

- ② Remove the sensor cover.

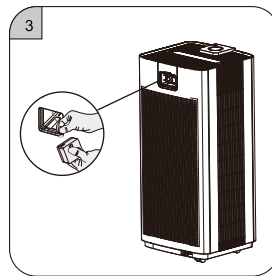

- ③ Hold on the hardware handle and pull out the sensor module.

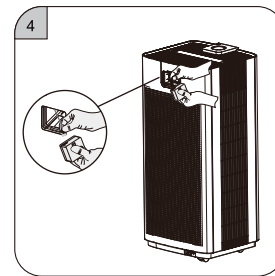

- ④ Unplug the terminal block from the old sensor module and replace it into a new sensor module.

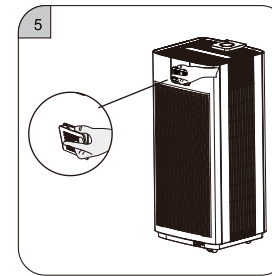

- ⑤ Put back the sensor module and close the sensor cover.

Cleaning and Maintenance

Cleaning and Maintenance

Please unplug the power plug from the adapter before machine maintenance.

1、 Clean the machine body (cleaning once a month is recommended):

- 1) Wipe off stains with a soft rag.
- 2) Wipe off stubborn stains with a soft rag dipped with proper amount of neutral detergent.

Note: Please avoid scratching the machine shell with any hard object during maintenance. Please operate according to the manual and avoid damaging any machine part during base disassembly.

2、 Clean and change the filter (once operation every 3-6 months is recommended):

- 1) The replacement of filter will be reminded by the built-in program. The filter can also be replaced according to the service life prompt of filter. It can also be replaced in real time through the filter life reset function.

The filter life is set as 3000 hours. The filter life indicators go off by one for every 600 hours of life used. When the rest filter life is less than 150 hours, the filter life reset key lights up in red and the last indicator keeps flashing (1Hz), prompting that the filter mesh needs to be replaced before the filter life is reset.

Reset of filter life:

When the rest filter life is not less than 150 hours, it can't be reset by touching the filter life reset key (for more than 3s) but only makes a prompt tone "ding". When the rest filter life is less than 150 hours, the filter life reset key flashes; in this case, the filter life can be reset by touching the reset key (for more than 3s) and makes a prompt tone "ding". The filter life indicators are fully on when the parameter is successfully reset.

Forcible reset of filter life:

Press and hold the "Auto button" + "Sleep button" (for more than 3s) with in 30s of power-on state in the standby mode, the filter life will be reset forcibly and make a prompt tone "ding". The screen will flash (2 times/s) 6 times, which indicates the completion of forcible reset. After the machine is restarted, all the filter life indicators will be fully on.

- 2) The vacuum cleaner can be used to clean the deposited dust on the surface of the composite filter mesh to prolong the service life of filter mesh (it is recommended to clean it once every other month and do not wash with water).

*The service life of filter mesh may vary with different environments for using the machine. For example, it will be shortened in smoking areas and areas with pets. Please replace the filter mesh in time when the purification effect becomes worse.

*Please dispose the used waste filter mesh according to the relevant regulations on solid waste.

Filter replacement

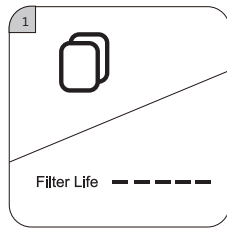

1. When the reset button of filter life lights up in red and the last indicator begins to flash, it prompts that the filter needs to be replaced.

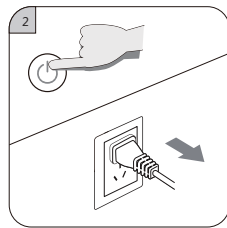

2. Touch the on-off button to power off, and unplug the machine.

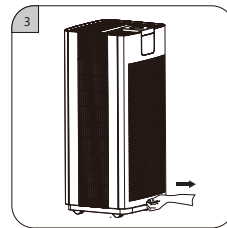

3. Pull the filter cover out slightly.

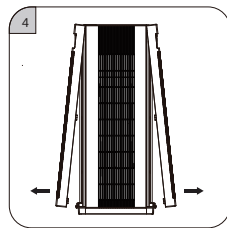

4. Take out the filter cover.

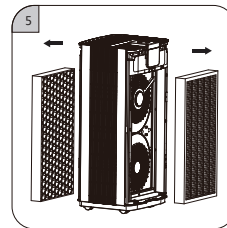

5. Take out the failed filter in the machine.

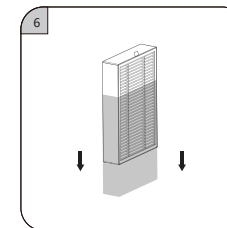

6. Remove the plastic film from the new filter.

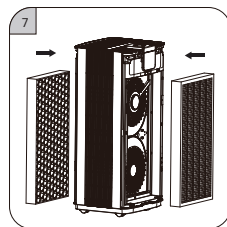

7. Reinstall the new filter in the machine.

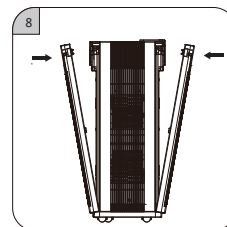

8. Put the filter cover back

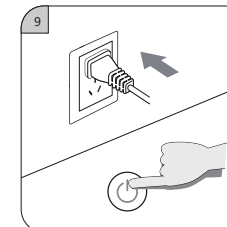

9. Plug in and touch the on-off button .

Troubleshoot Guide

Failures	Possible Causes	Solutions
The product cannot function normally	1. There are problems in connection. 2. The filter cover is not properly installed.	1. Check if the plug is plugged into the socket and if the power button is turned on. 2. Reinstall the filter cover.
The air cannot be ducted smoothly from the air outlet	1. The plastic package of the new filter is not removed. 2. The air outlet of purifier is blocked by foreign matters.	1. Please remove the plastic package at first. 2. Clean up the foreign matters.
The machine makes noise while functioning	1. The inlet or outlet is blocked by foreign matters. 2. There are foreign matters in the air flue of machine.	1. Please remove the obstructive matters first. 2. Clean up the foreign matters.
The indicator light for filter change is still flashing after change.	1. The filter reset button has not been pressed.	1. Press and hold the filter button for more than 3 seconds, and complete the filter reset after hearing a prompt tone "ding".
The wind speed seems to decrease	1. The filter life has expired, or the filter is blocked by hair.	1. Clean the dust and hair on the surface with a vacuum cleaner; change the failed filter.
The air purifier gives out odor	1. The pollutant concentration may be too high, and the filter may reach a saturated state in advance.	1. The filter needs to be changed to avoid secondary pollution.

The most frequently asked questions of this product are listed here. If you cannot find the solution to your question, please contact our after-sales service department.

Warranty & Support

Jafanda products have a **One Year warranty** from the date of purchase and a **Free Extended One -Year warranty** after registering your product with your order and purchase date via <https://www.jafanda.com/pages/warranty-registration>. Jafanda always takes responsibility for all our products. Jafanda always pays high importance to the customer's purchase experience and satisfaction.

Returns & Refunds

If for any reason you are not fully satisfied with your purchase experience within 30 days, we are happy to help with a replacement or refund. For more detail, please visit our after-sales website page: <https://www.jafanda.com/policies/refund-policy>.