

ASSEMBLY INSTRUCTIONS

Patio Furniture Set

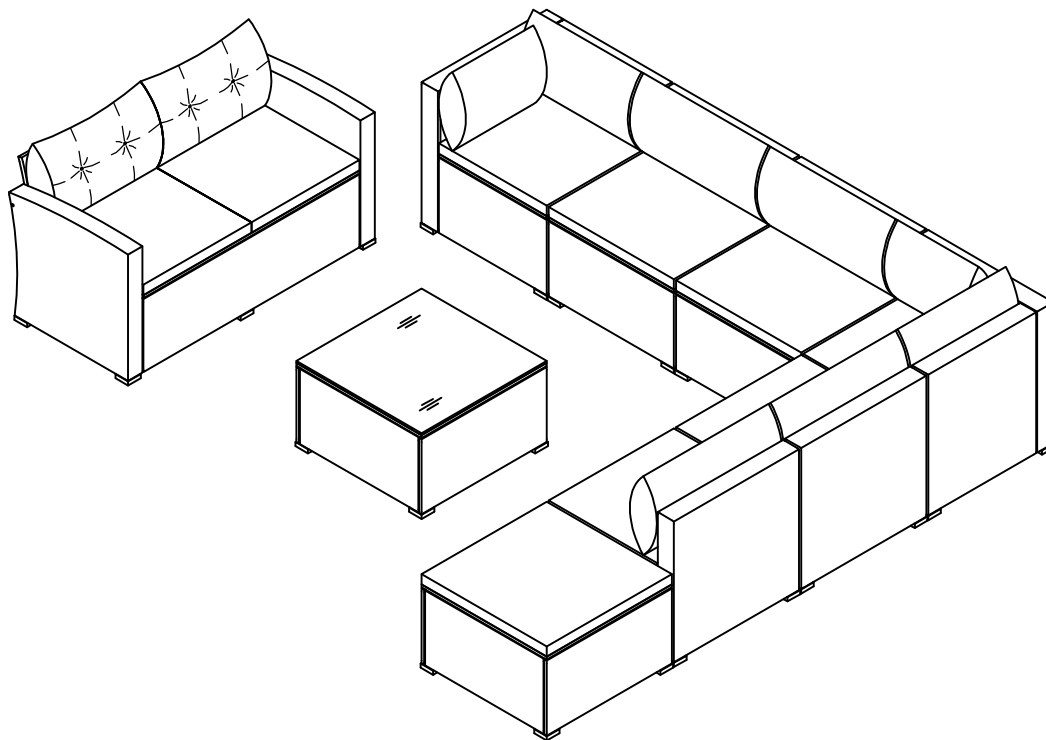

NOTE: 50% TIGHTEN BEFORE FIXING ALL BOLTS

WF301721

WF301722

WF301723

WF301724

WF301725

(4 x Armless sofa)

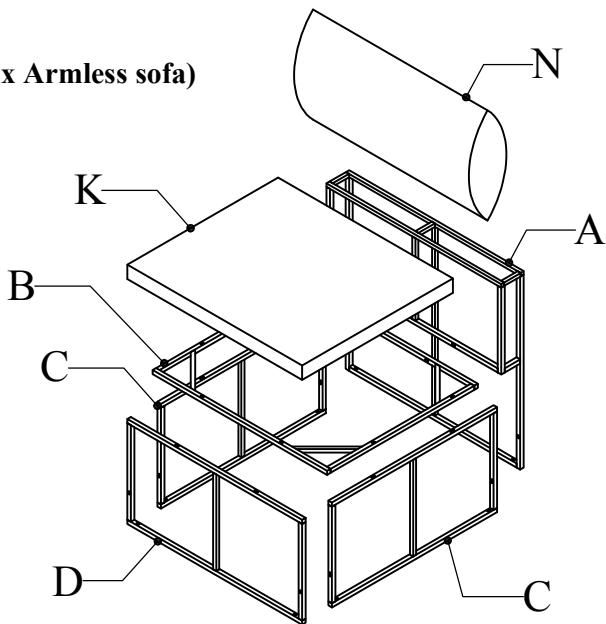

(2 x Corner sofa)

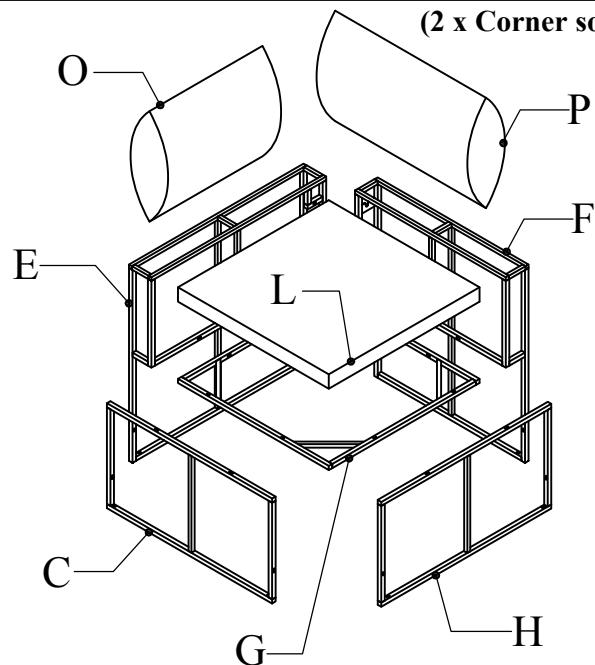

(1 x Ottoman)

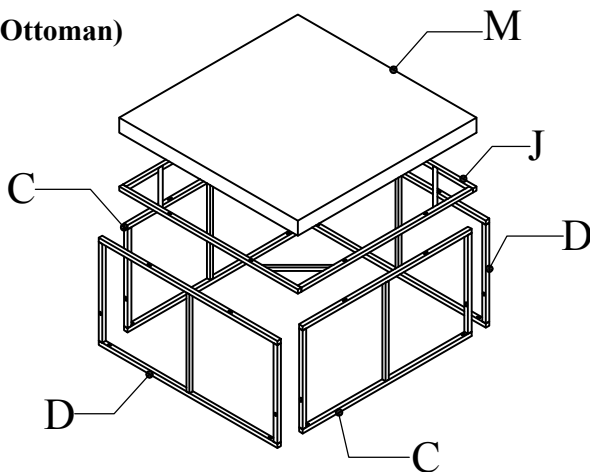

(1 x Table)

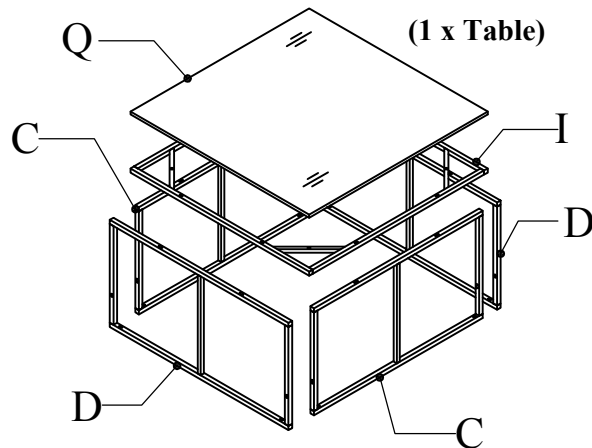

Notice:

1. 50% Tighten before fixing all screws, Allen wrench is recommended instead of an electric drill.
2. Place the item on a flat ground to adjust and make sure it remains stable
3. Tighten up all screws with tools gradually.
4. If the screws are not aligned with holes during assembly, please loosen all the other screws to 50% and continue the assembly process.
5. If the item is not stable, please loosen all the screws, adjust it on a flat ground and tighten up all screws again.
6. Note : If one or some screws are fully tightened during assembly, chances are the others will not be aligned with holes. In addition, all the holes are designed to be relatively larger to provide more space for the adjustment of the screws.

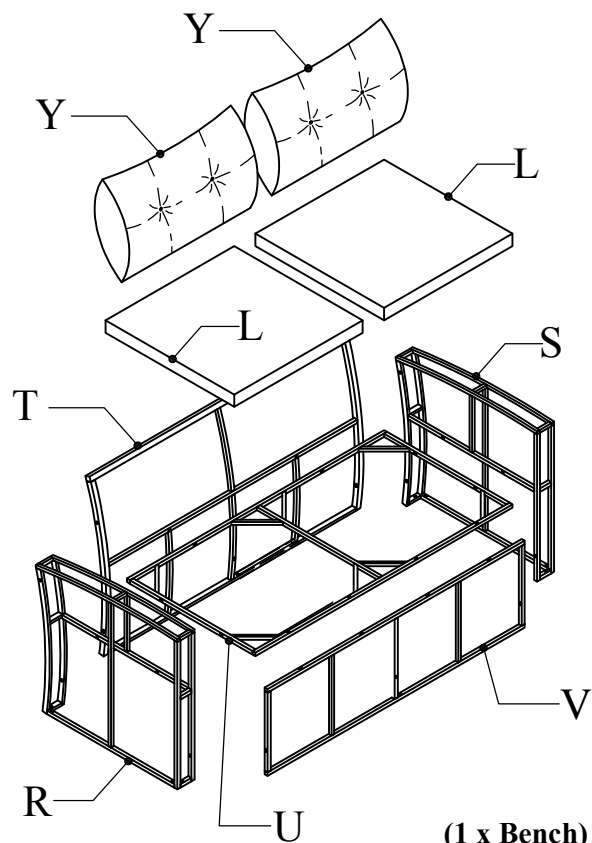

(1 x Bench)

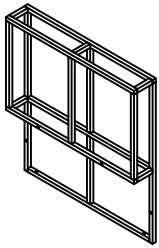
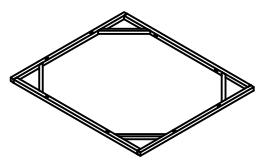
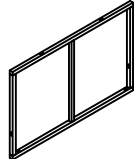
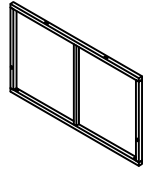
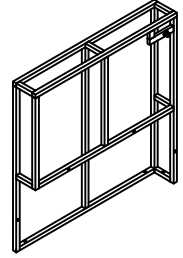
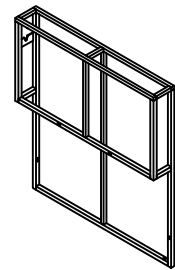
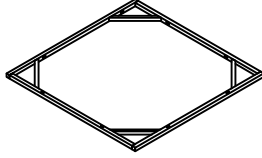
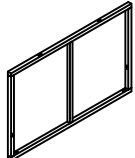
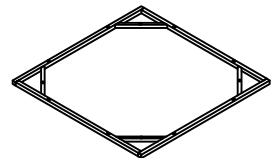
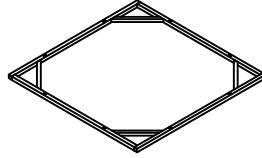
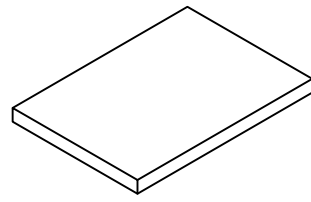
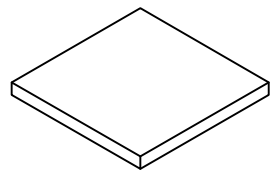
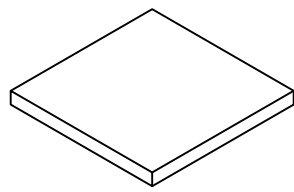
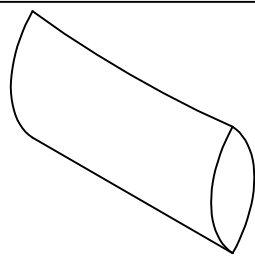
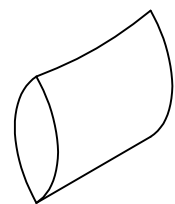
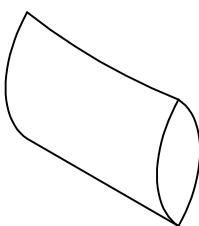
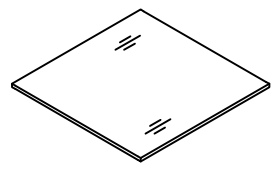
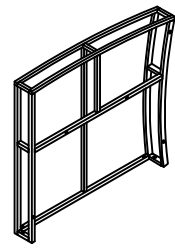

Part List

<p>A</p>  <p>Back Frame (4pcs)</p>	<p>B</p>  <p>Seat Frame (4pcs)</p>	<p>C</p>  <p>Side Frame (14pcs)</p>
<p>D</p>  <p>Front Frame (8pcs)</p>	<p>E</p>  <p>Big Corner Frame (2pcs)</p>	<p>F</p>  <p>Small Corner Frame (2pcs)</p>
<p>G</p>  <p>Corner Seat Frame (2pcs)</p>	<p>H</p>  <p>Corner front Frame (2pcs)</p>	<p>I</p>  <p>Table top Frame (1pc)</p>
<p>J</p>  <p>Ottoman Frame (1pc)</p>	<p>K</p>  <p>Seat Cushion (4pcs)</p>	<p>L</p>  <p>Corner & Bench seat Cushion (4pcs)</p>
<p>M</p>  <p>Ottoman Cushion (1pc)</p>	<p>N</p>  <p>Back Pillow (4pcs)</p>	<p>O</p>  <p>Small corner Pillow (2pcs)</p>
<p>P</p>  <p>Big corner Pillow (2pcs)</p>	<p>Q</p>  <p>Table Glass (1pc)</p>	<p>R</p>  <p>Bench Right Frame (1pc)</p>

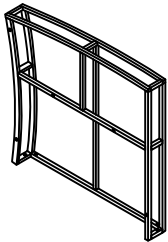
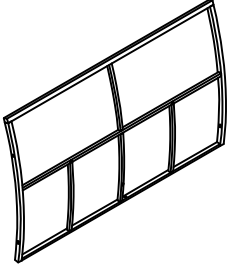
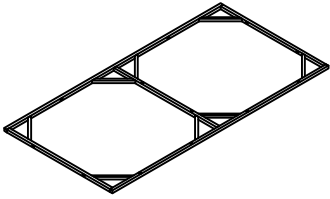
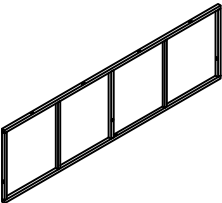
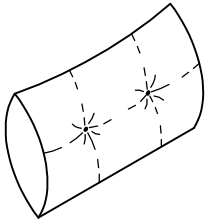
Part List

<p>S</p>  <p>Bench Left Frame (1pc)</p>	<p>T</p>  <p>Bench back Frame (1pc)</p>	<p>U</p>  <p>Bench Seat Frame (1pc)</p>
<p>V</p>  <p>Bench front Frame (1pc)</p>	<p>Y</p>  <p>Bench Back Pillow (2pcs)</p>	

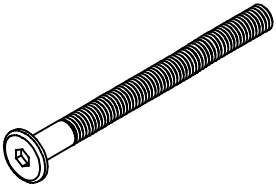
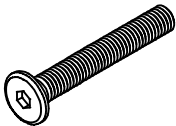
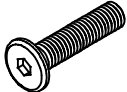
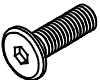
Hardware List

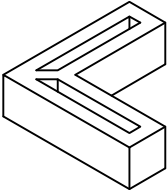
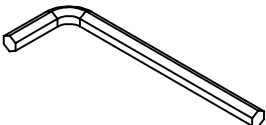
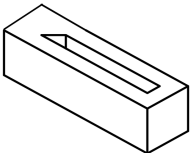
<p>1</p>  <p>Bolt M6 x 100 mm 2 pcs + extra 1 pc</p>	<p>2</p>  <p>Bolt M6 x 35 mm 8 pcs + extra 1 pc</p>	<p>3</p>  <p>Bolt M6 x 30 mm 104 pcs + extra 3 pcs</p>
<p>4</p>  <p>Bolt M6 x 25 mm 76 pcs + extra 3 pcs</p>	<p>5</p>  <p>W6x1 Washers 114 pcs + extra 3 pcs</p>	<p>6</p>  <p>Plastic feet (36pcs)</p>
<p>7</p>  <p>Allen key M4 (3 pcs)</p>	<p>8</p>  <p>Plastic feet (2pcs)</p>	

CARTON CONTENT:

WF301721

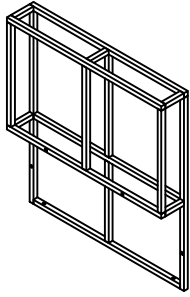

A x 4

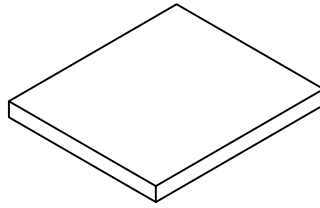

K x 4

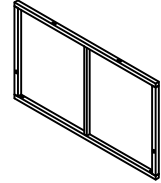

D x 6

WF301722

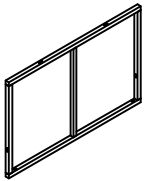

C x 2

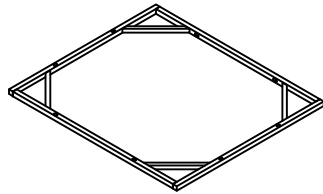

B x 4

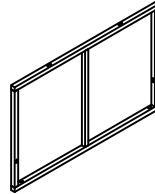

H x 2

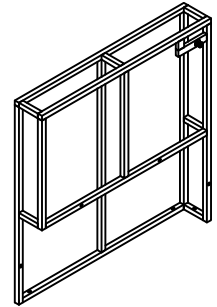

E x 2

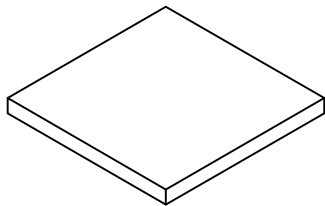

L x 2

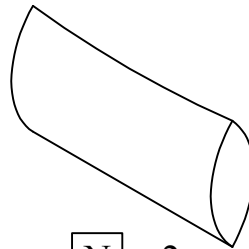

N x 2

WF301723

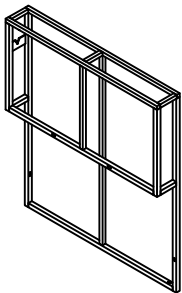

F x 2

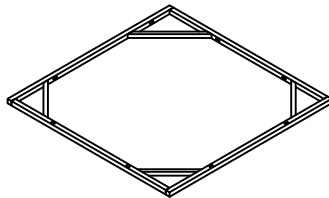

G x 2

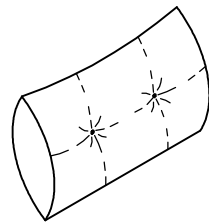

Y x 2

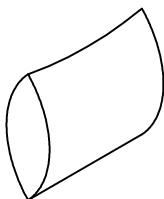

O x 2

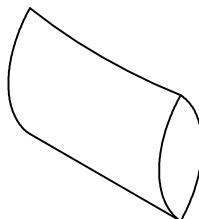

P x 2

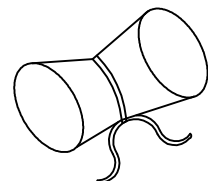

HARDWARE

CARTON CONTENT:

WF301724

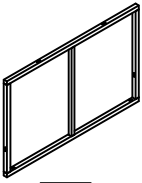

C x 12

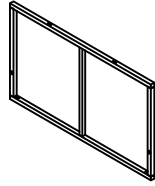

D x 2

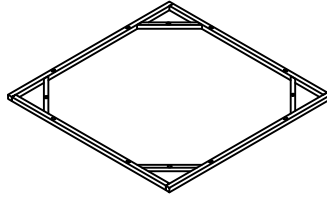

I x 1

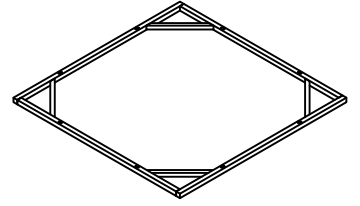

J x 1

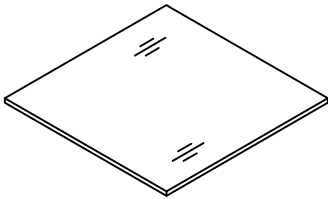

Q x 1

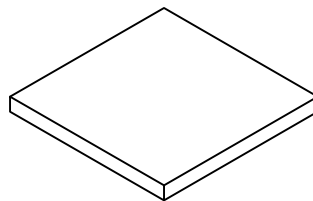

M x 1

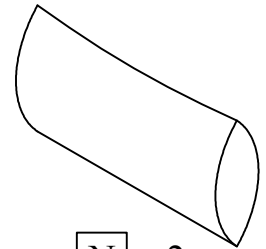

N x 2

WF301725

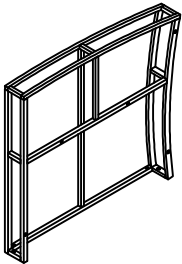

R x 1

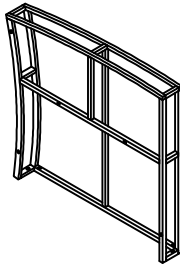

S x 1

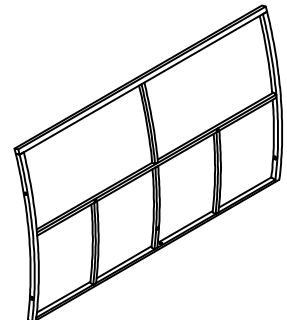

T x 1

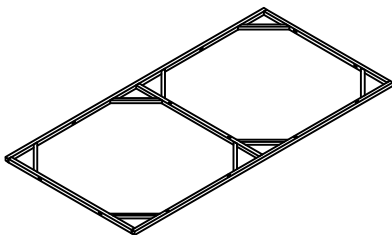

U x 1

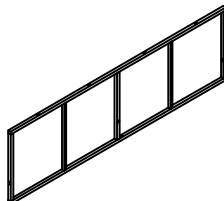

V x 1

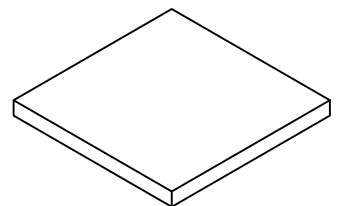

L x 2

STEP 1 (4 x Armless sofa assembly)

Connect Back Frame (A) & Seat Frame (B) with Bolt (3) & Washers (5)

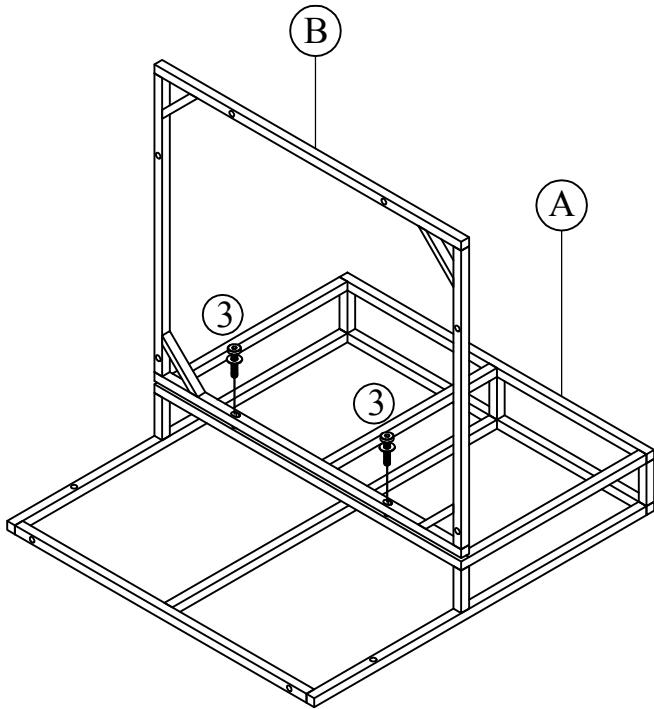

STEP 2

Connect Part from STEP 1 & Side Frame (C) with Bolt (3) & Washers (5)

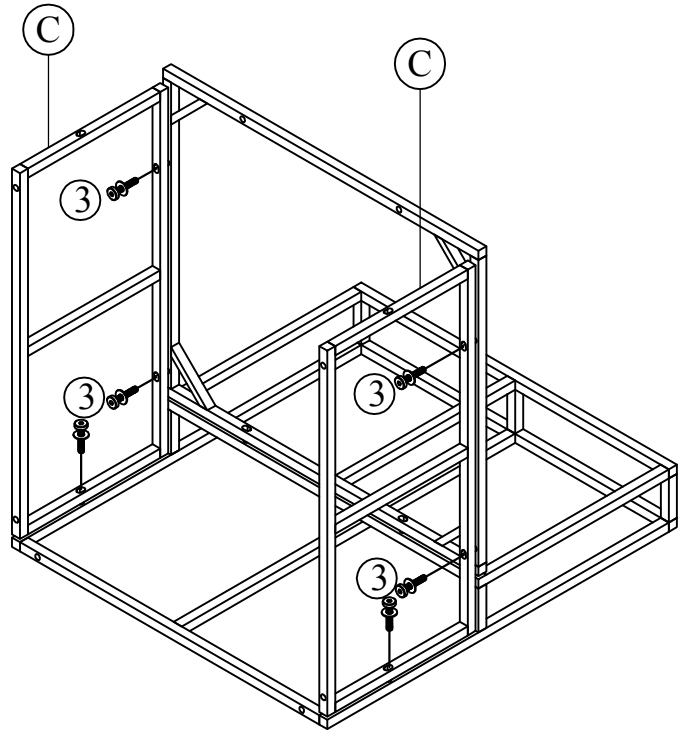

STEP 3

Connect Part from STEP 2 & Front Frame (D) with Bolt (3) & Washers (5)

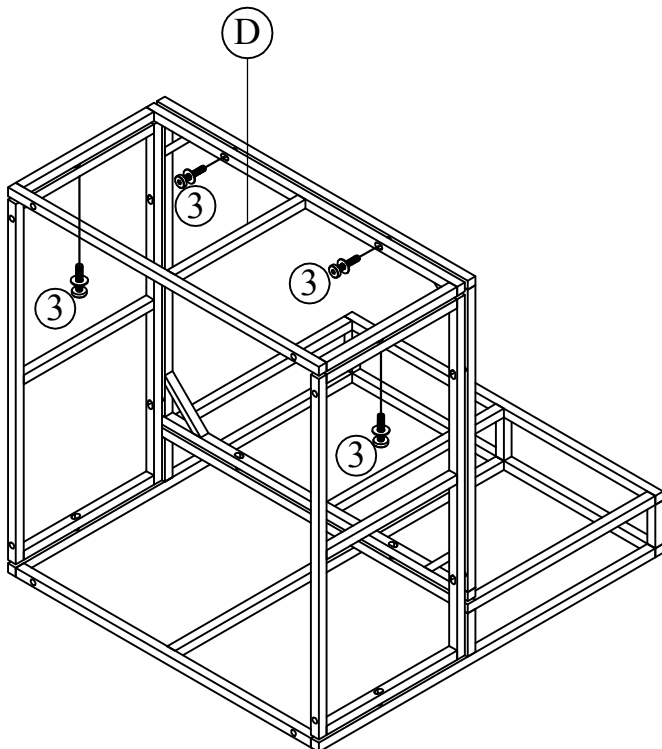

STEP 4

Connect Part from STEP 3 & Plastic feet (6) with Bolt (4)

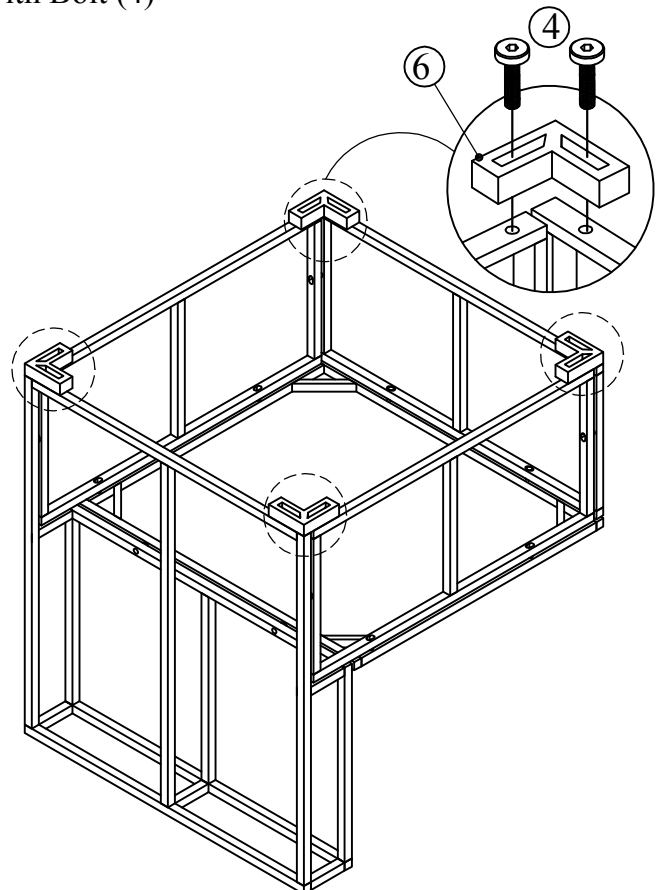

STEP 5

Put on Seat Cushion (K) & Back Pillow (N) to complete Armless sofa

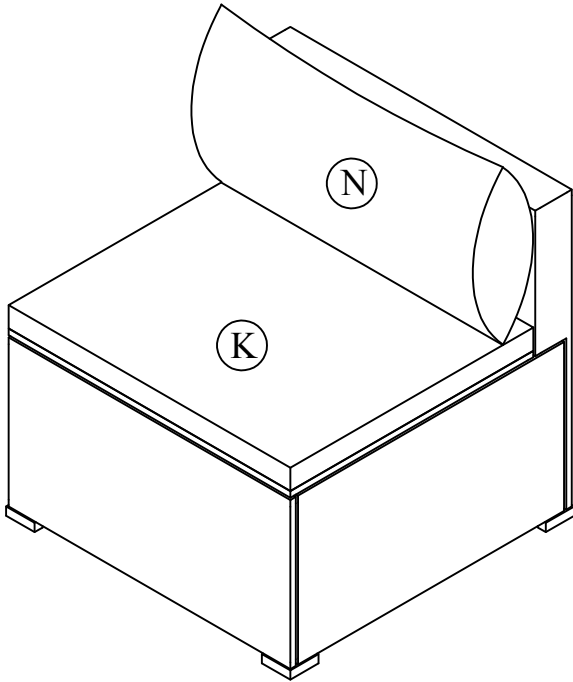

STEP 6 (2 x Corner sofa assembly)

Connect Small Corner Frame (F) & Corner Seat Frame (G) with Bolt (3) & Washers (5)

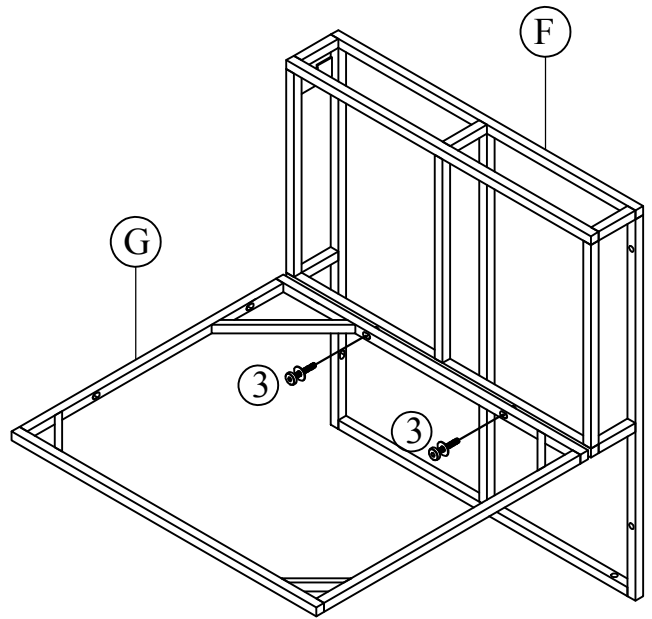

STEP 7

Connect Part from STEP 6 & Big corner Frame (E) with Bolt (3) & Washers (5)

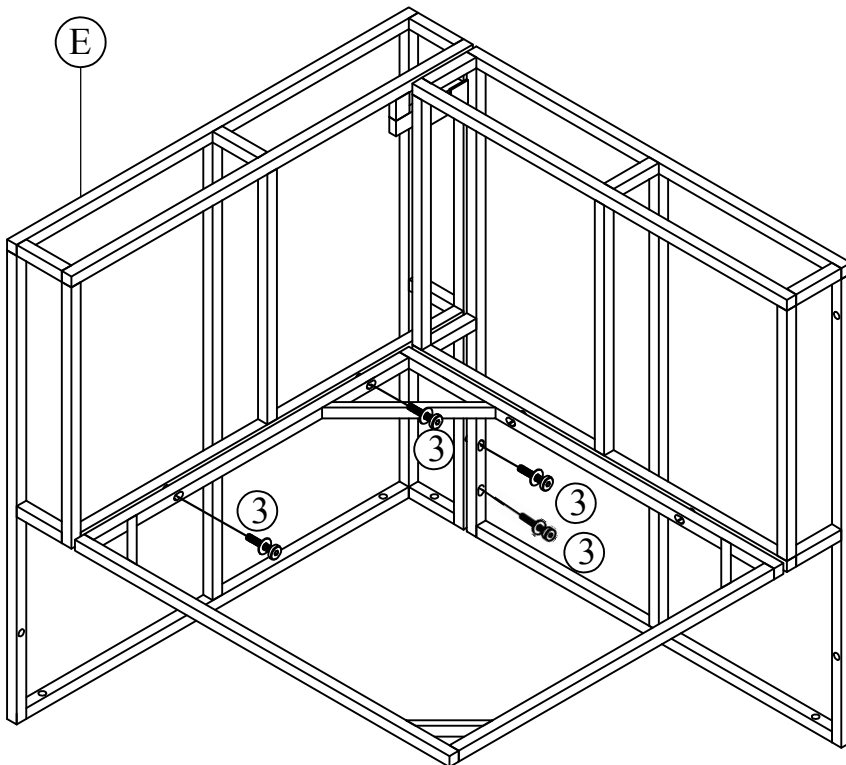

STEP 8

Connect Part from STEP 7 & Side Frame (C) with Bolt (3) & Washers (5)

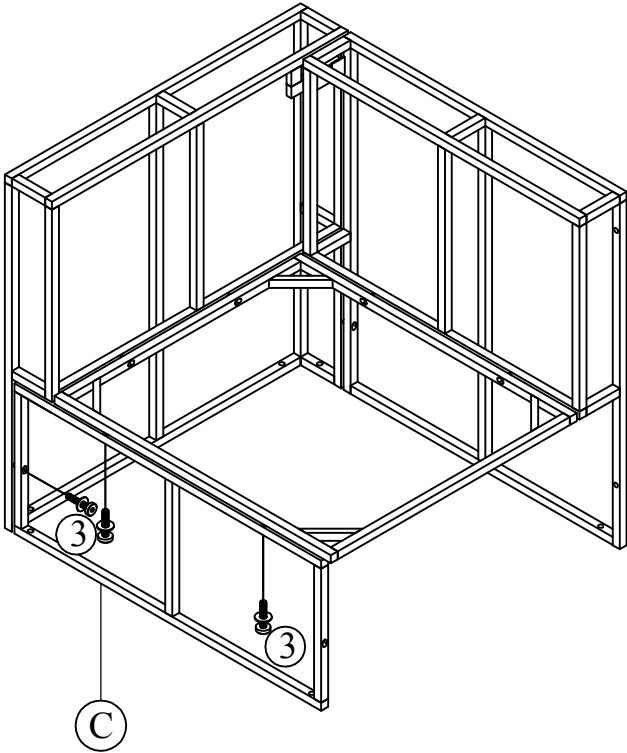

STEP 9

Connect Part from STEP 8 & Corner front Frame (H) with Bolt (3) & Washers (5)

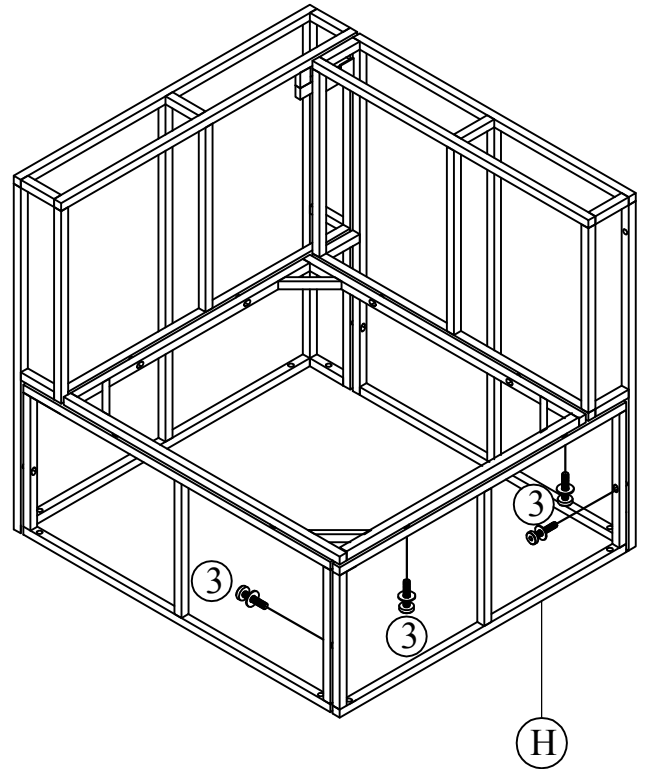

STEP 10

Connect Part from STEP 9 & Plastic feet (6) with Bolt (4)

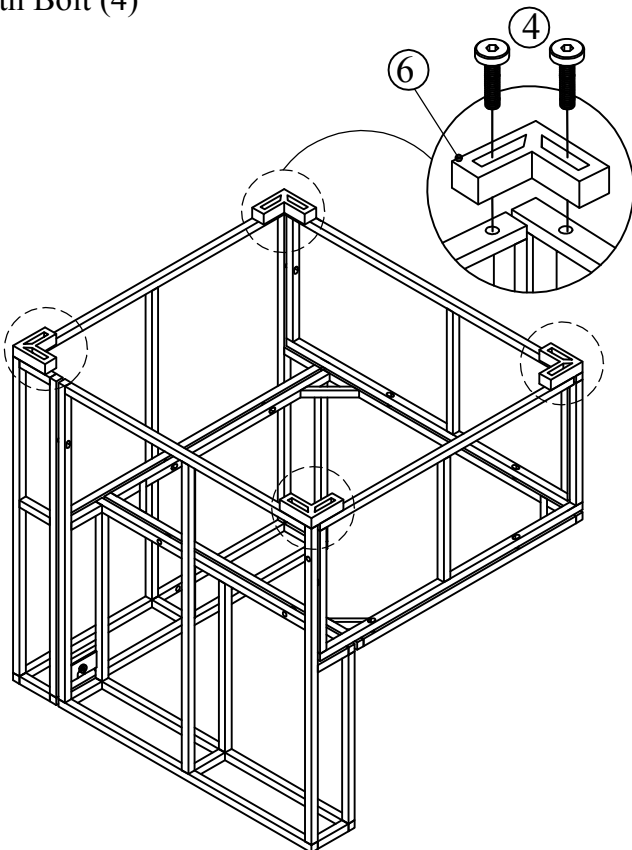

STEP 11

Put on Corner Seat Cushion (L) & Big Corner Pillow (P) & Small Corner Pillow (O) to complete Corner sofa

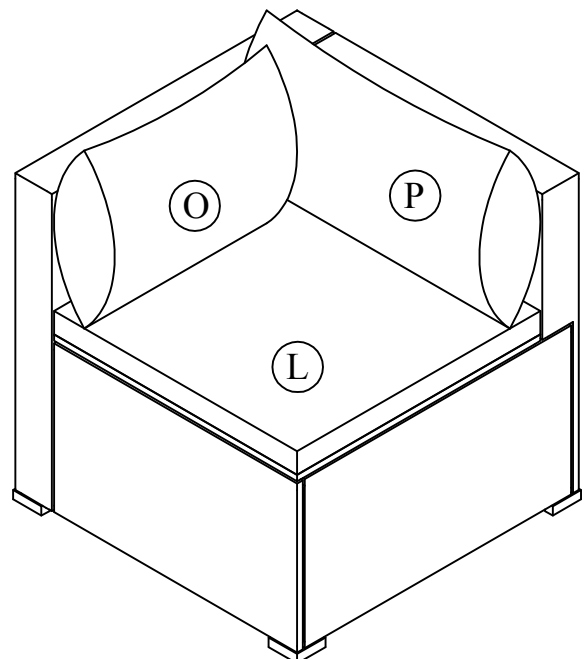

STEP 12 (1 x Ottoman assembly)

Connect Ottoman Frame (J) & Front Frame (D) & Side Frame (C) with Bolt (3) & Washers (5)

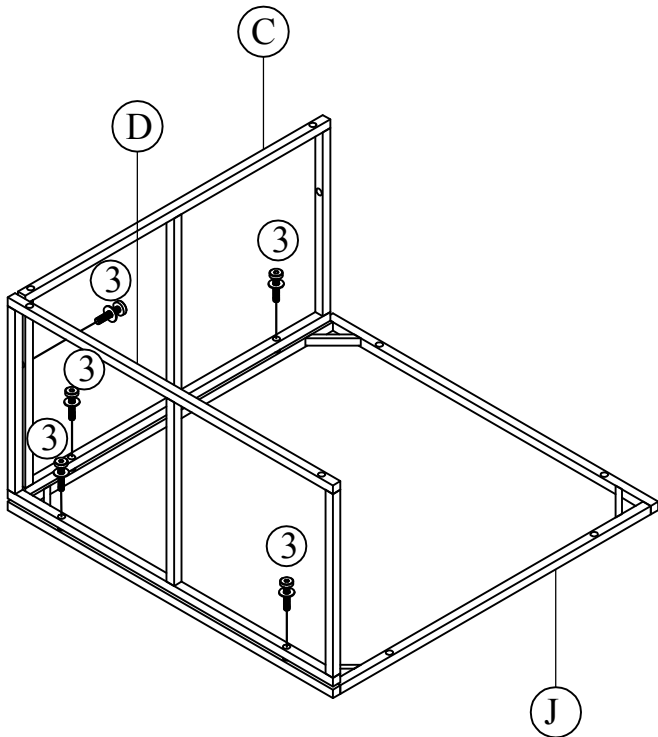

STEP 13

Connect part from STEP 12 & Side Frame (C) & Front Frame (D) with Bolt (3) & Washers (5)

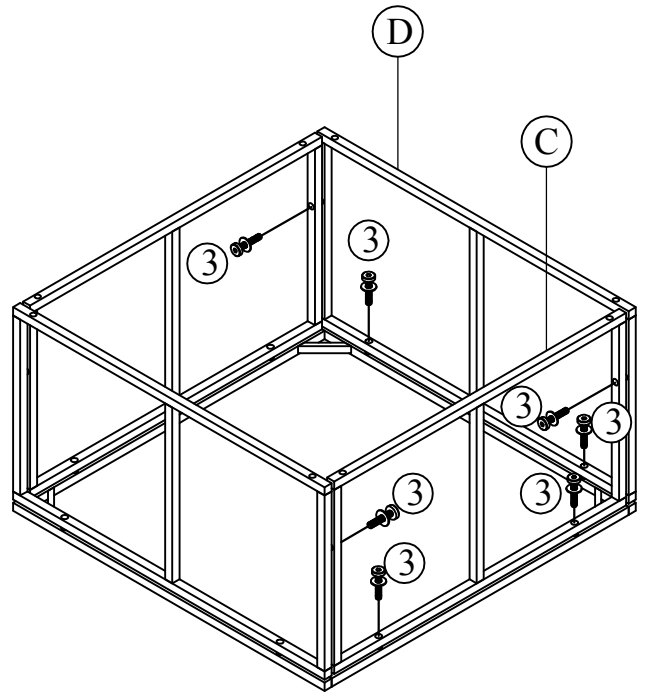

STEP 14

Connect Part from STEP 13 & Plastic feet (6) with Bolt (4)

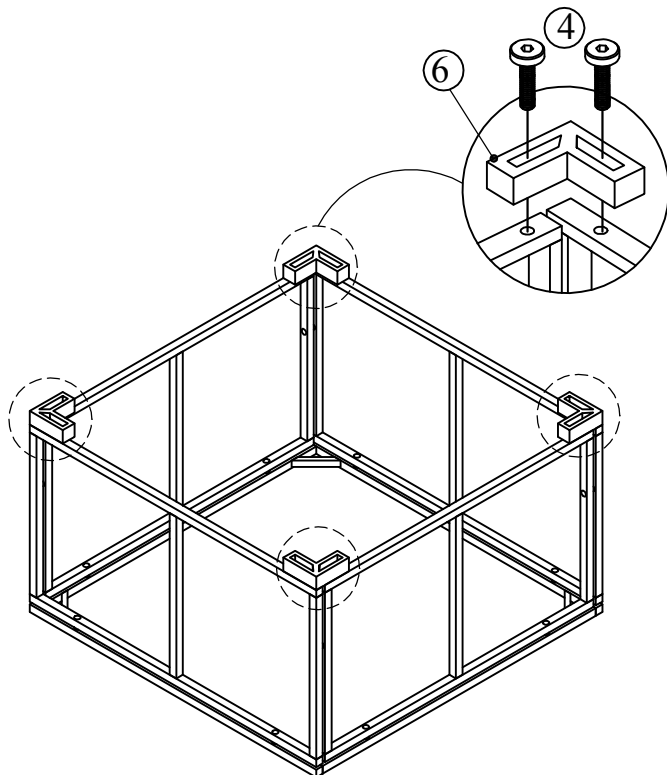

STEP 15

Put on Ottoman Cushion (M) to complete Ottoman

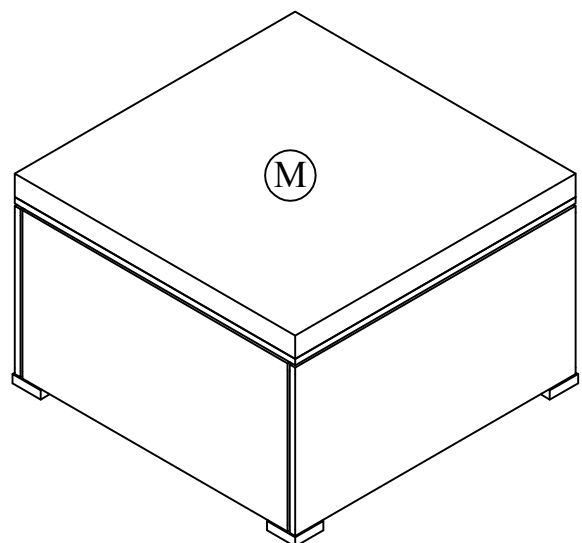

STEP 16 (1 x Table assembly)

Connect Table top Frame (I) & Front Frame (D) & Side Frame (C) with Bolt (3) & Washers (5)

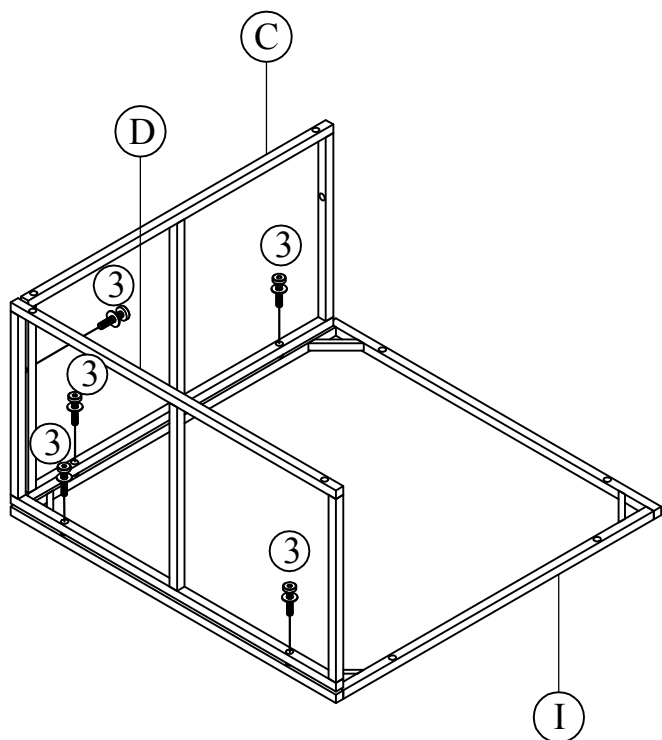

STEP 17

Connect part from STEP 16 & Side Frame (C) & Front Frame (D) with Bolt (3) & Washers (5)

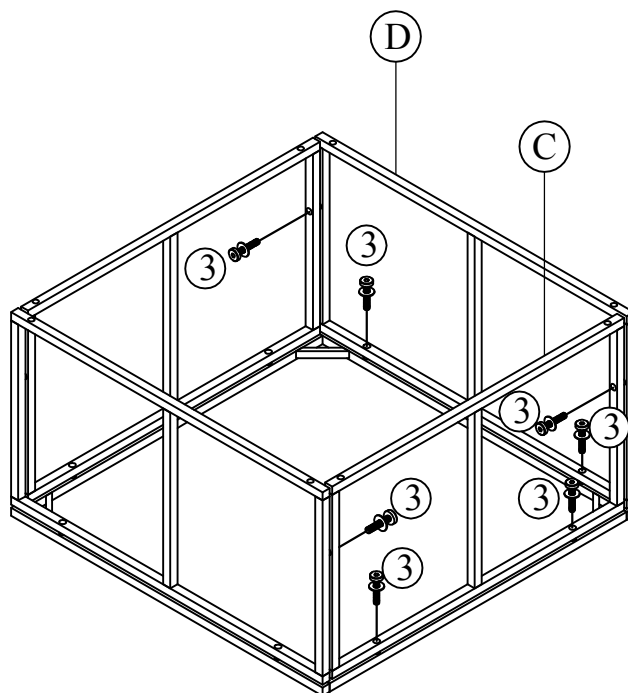

STEP 18

Connect Part from STEP 17 & Plastic feet (6) with Bolt (4)

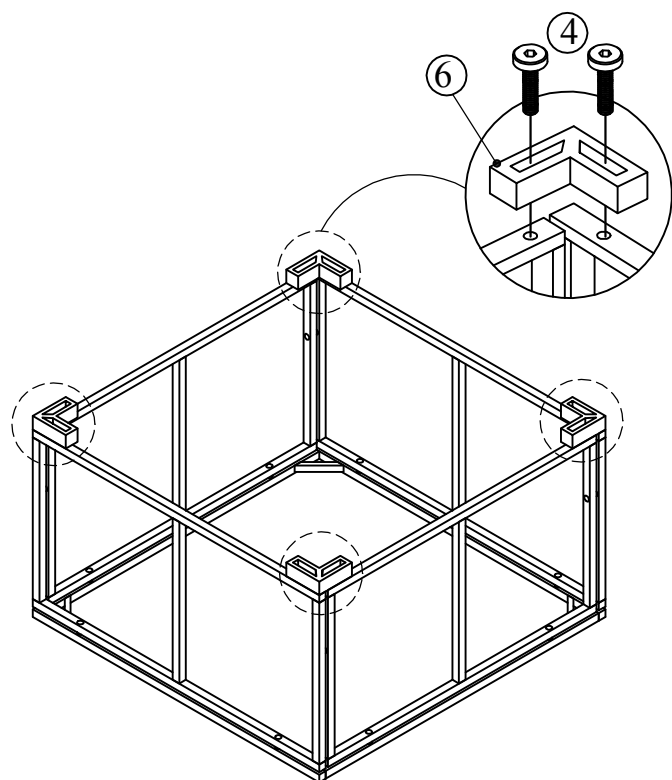

STEP 19

Put on Table Glass (Q) to complete Table

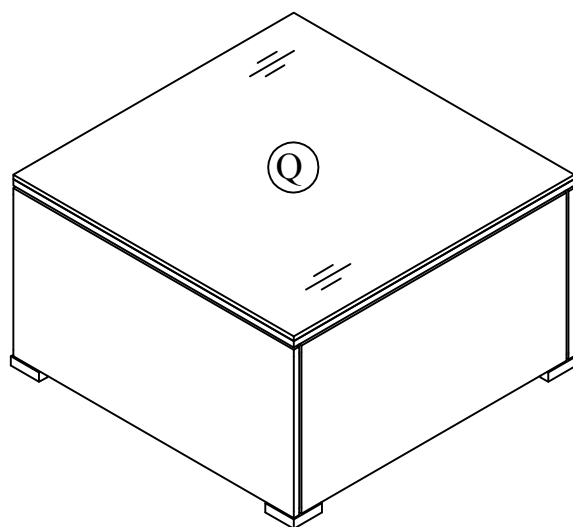

STEP 20 (1 x Bench essembly)

Connect Bench Seat Frame (U) & Bench Front Frame (V) with Bolt (3) & Washers (5)

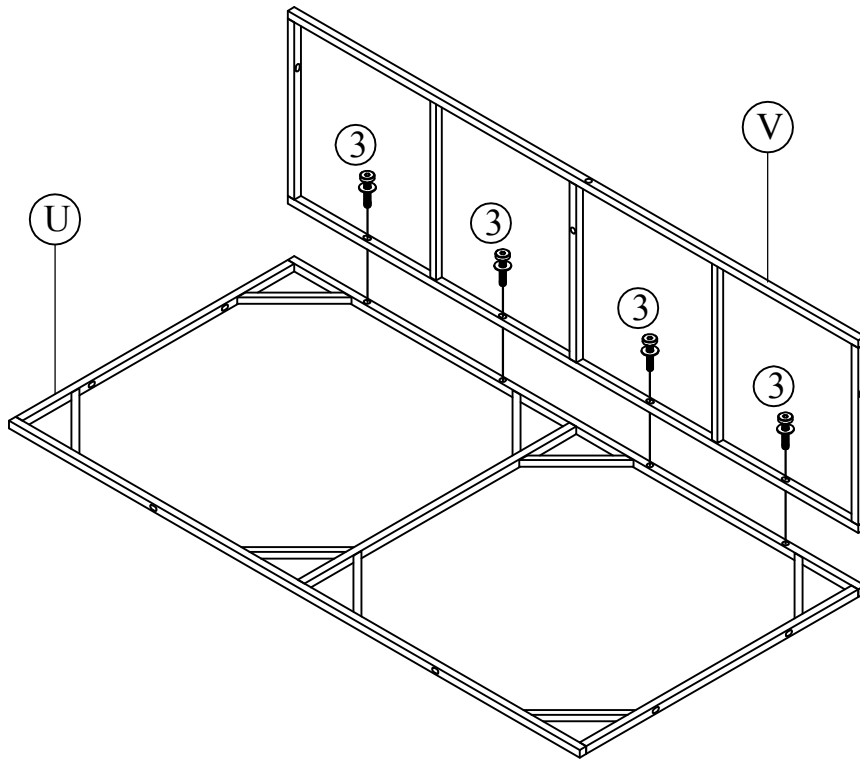

STEP 21

Connect Part from STEP 20 & Bench back Frame (T) with Bolt (2), (3) & Washers (5)

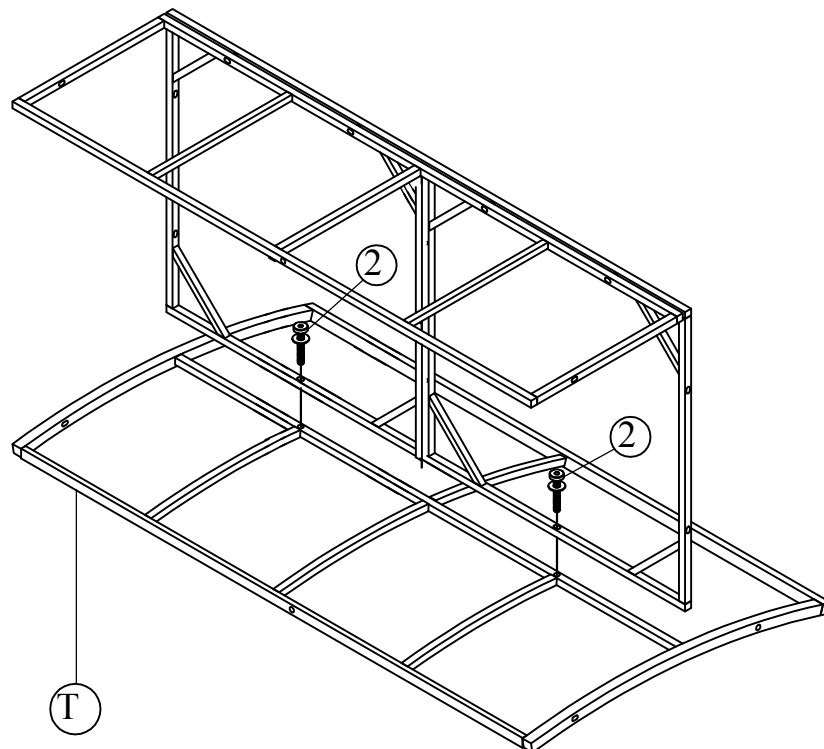

STEP 22

Connect Part from STEP 21 & Bench Right Frame (R) with Bolt (2), (3) & Washer (5)

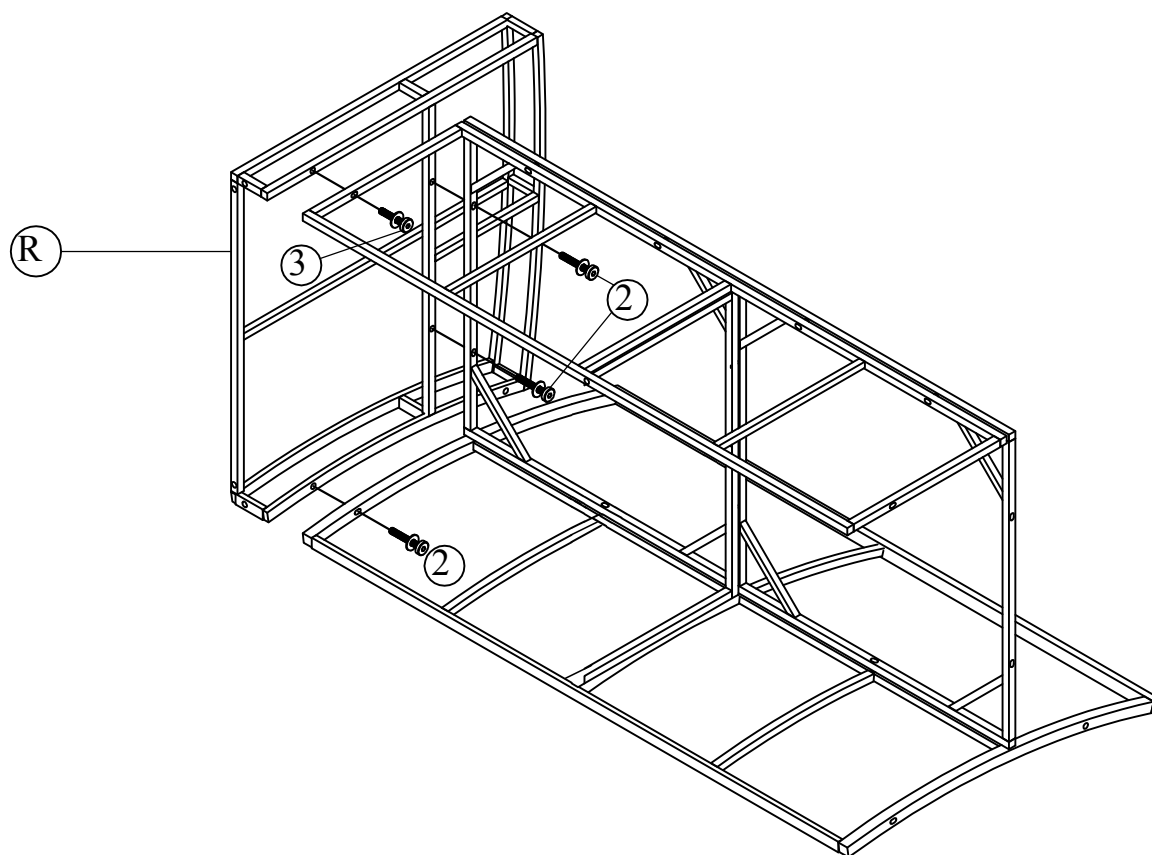

STEP 23

Connect Part from STEP 22 & Bench Left Frame (S) with Bolt (2), (3) & Washer (5)

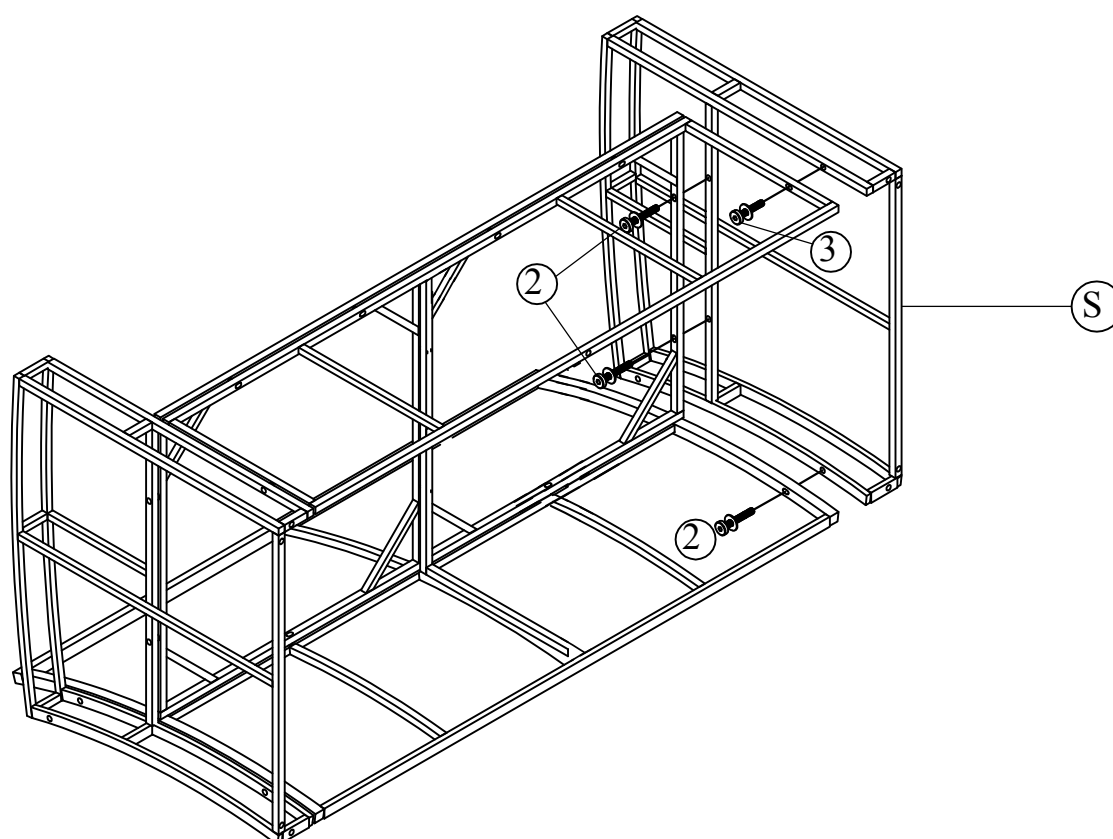

STEP 24

Connect Part from STEP 23 & Plastic feet (6)(9) with Bolt (4)

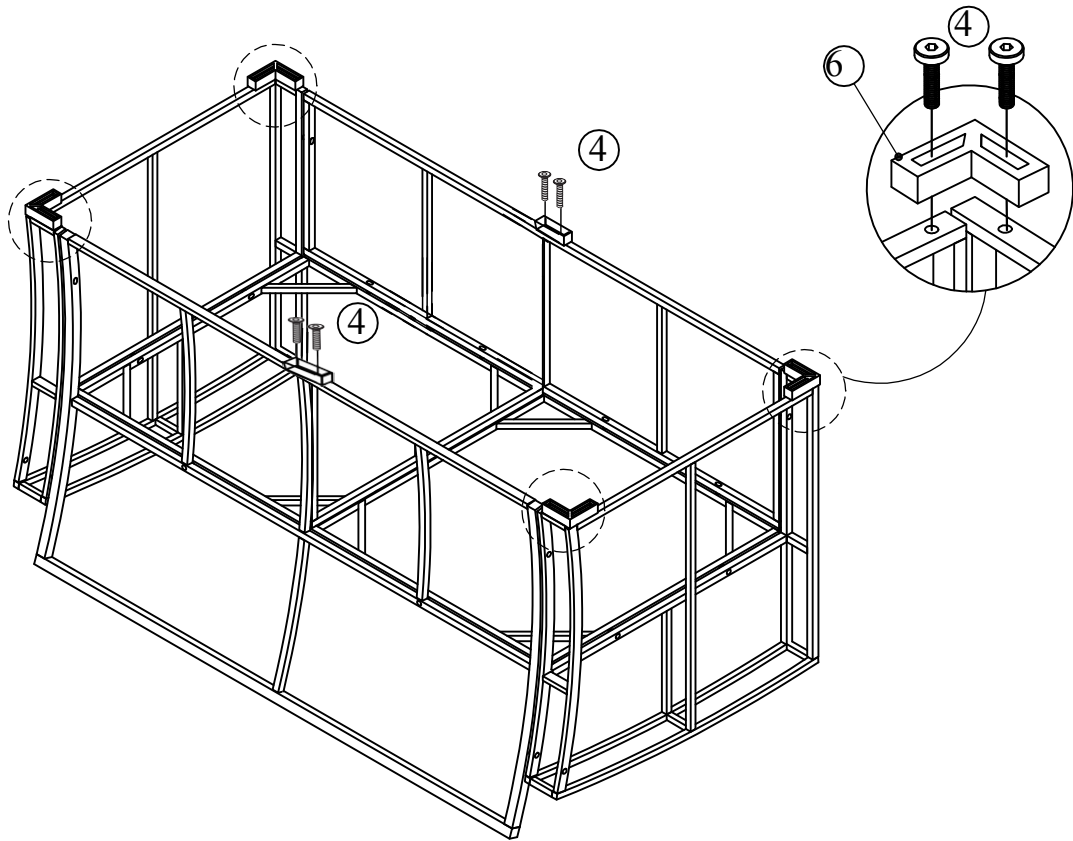

STEP 25

Connect the parts of the Bench back frame (T) & Bench right frame (R) and Bench left frame (S) completed in STEP 24 with Bolts (1) and Washers (5)

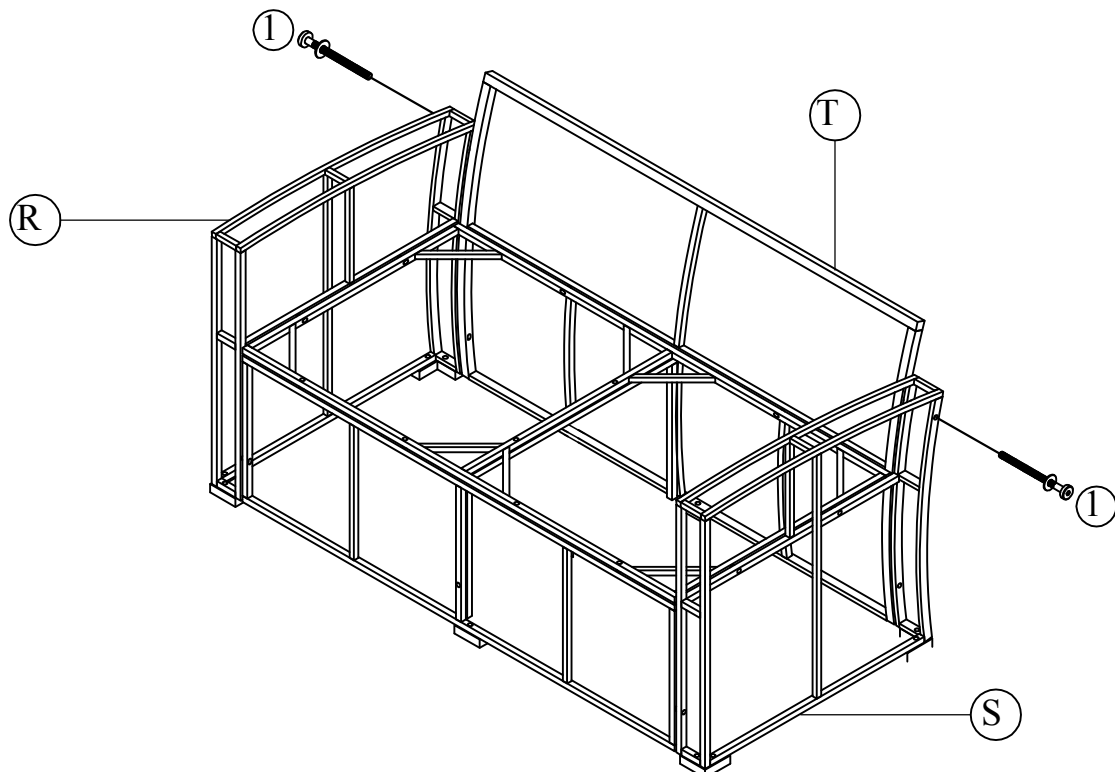

STEP 26

Put on Bench Seat Cushion (L) & Bench Back Pillow (Y) to complete Bench sofa

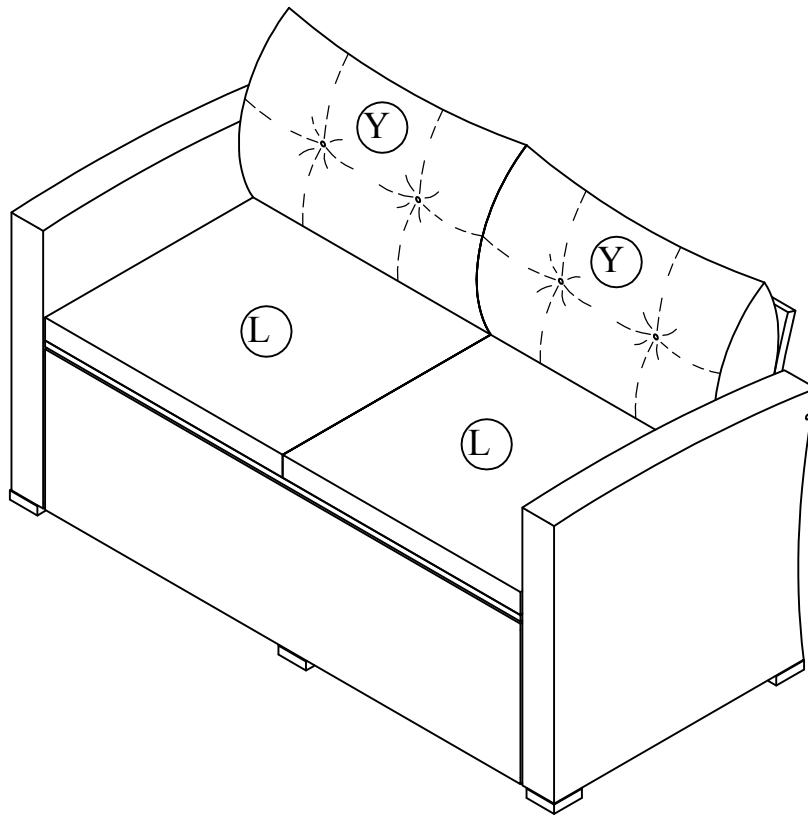

STEP 27

