

ASSEMBLY INSTRUCTIONS

ITEM NO.FB3068HAY-T

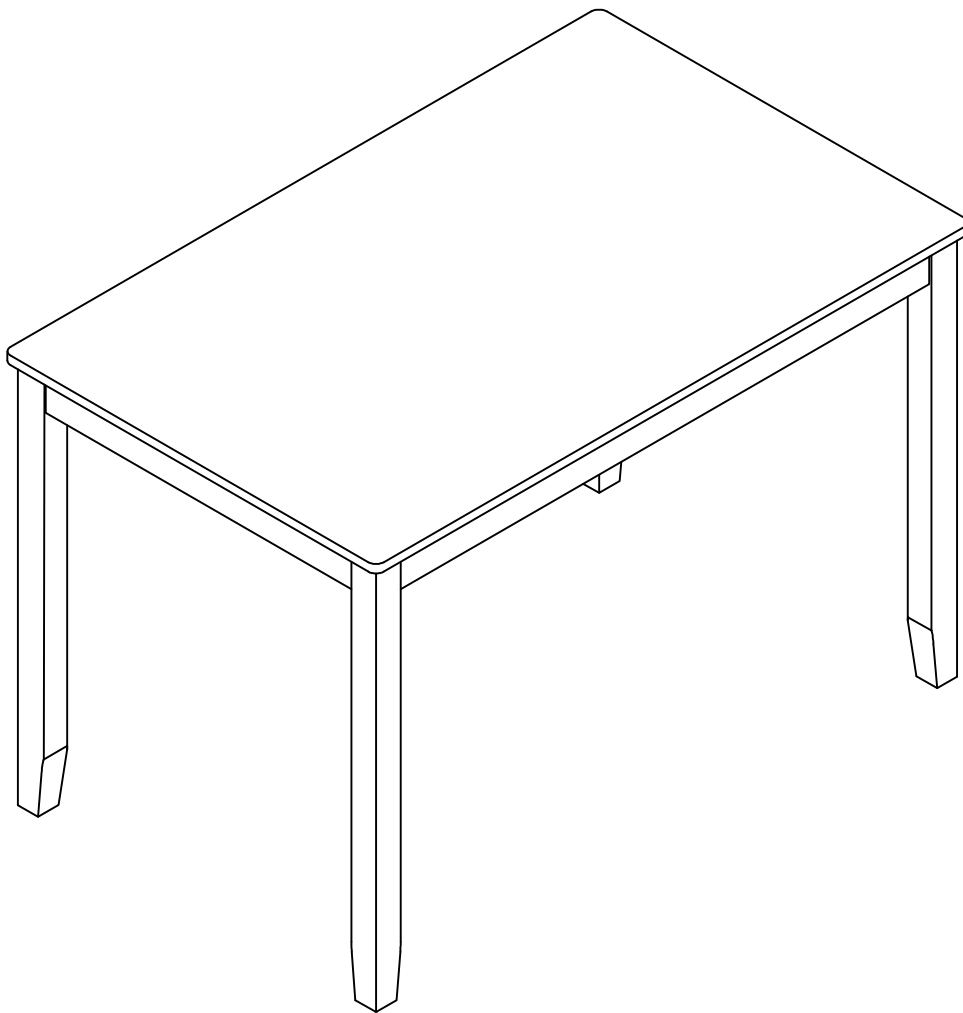



ASSEMBLY TIPS:

1. Remove hardware from box and sort by size.
2. Please check to see that all hardware and parts are present prior to start of assembly.
3. Please follow attached instructions in the same sequence as numbered to assure fast & easy assembly.

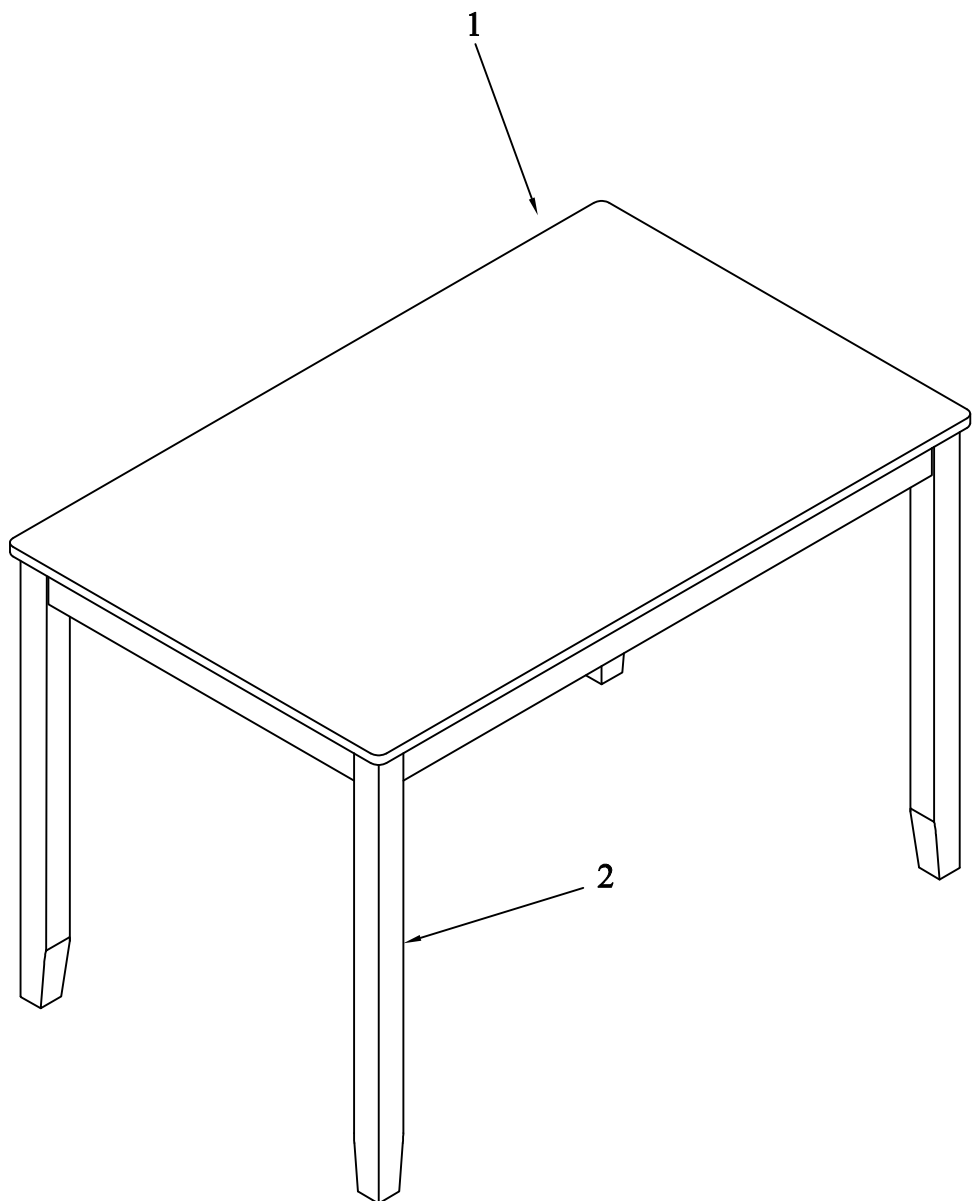

Exploded View



PARTS LIST

NO.	DIAGRAM	PART NAME	Q'Ty
1		TABLE TOP	1PC
2		LEG	4PCS

HARDWARE LIST

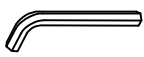
NO.	DIAGRAM	PART NAME	Q'Ty
A		BOLT / BOULON Ø5/16" x 2-1/2"	8PCS
B		LOCK WASHER Ø5/16"1/16	8PCS
C		FLAT WASHER Ø5/16"x 22mm	8PCS
D		ALLEN KEY 1/6" x 2-1/4"	1PC

STEP 1:

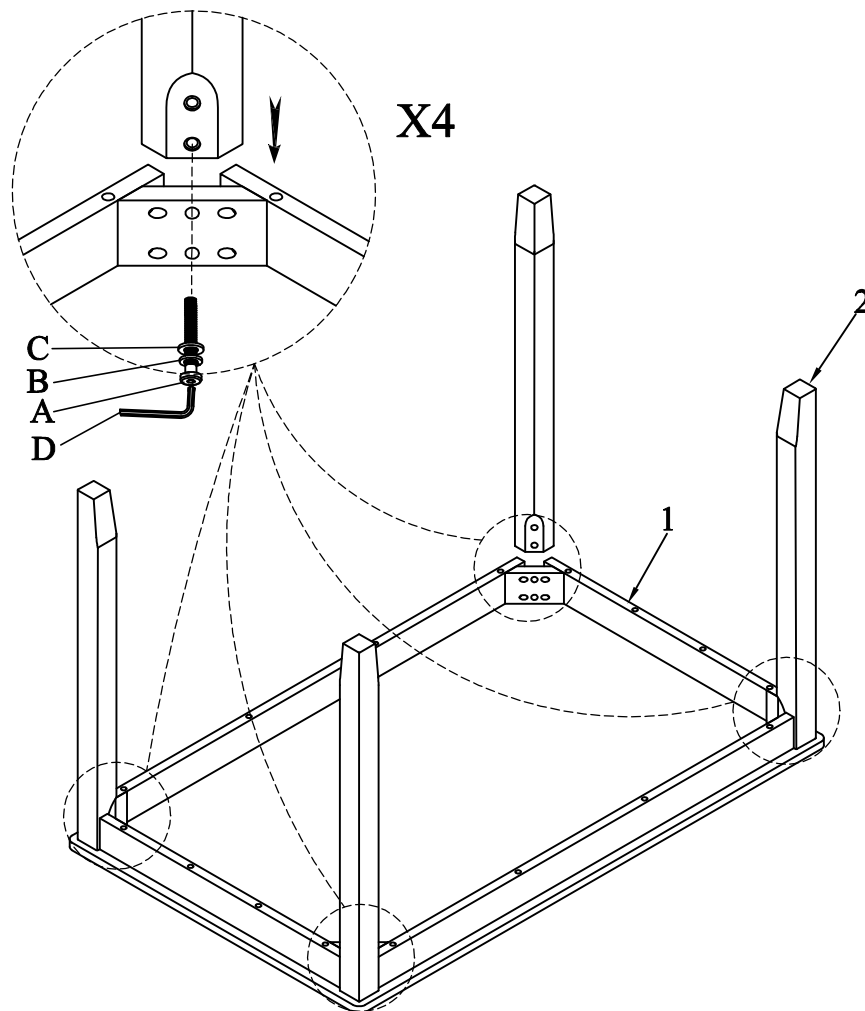

COMPLETED :

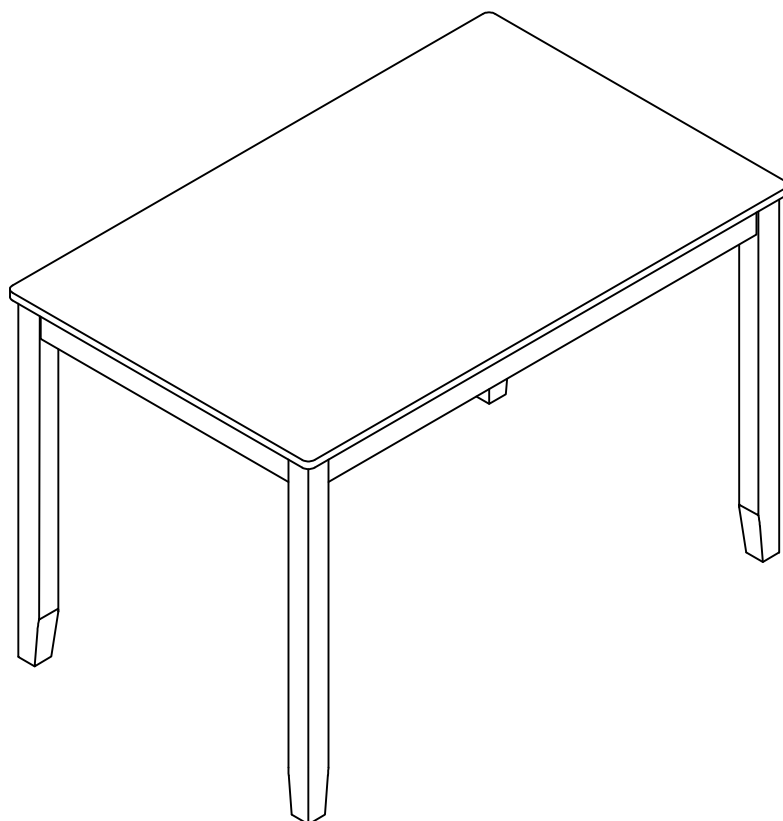

Tighten all screws until completely assembled.

ASSEMBLY INSTRUCTIONS

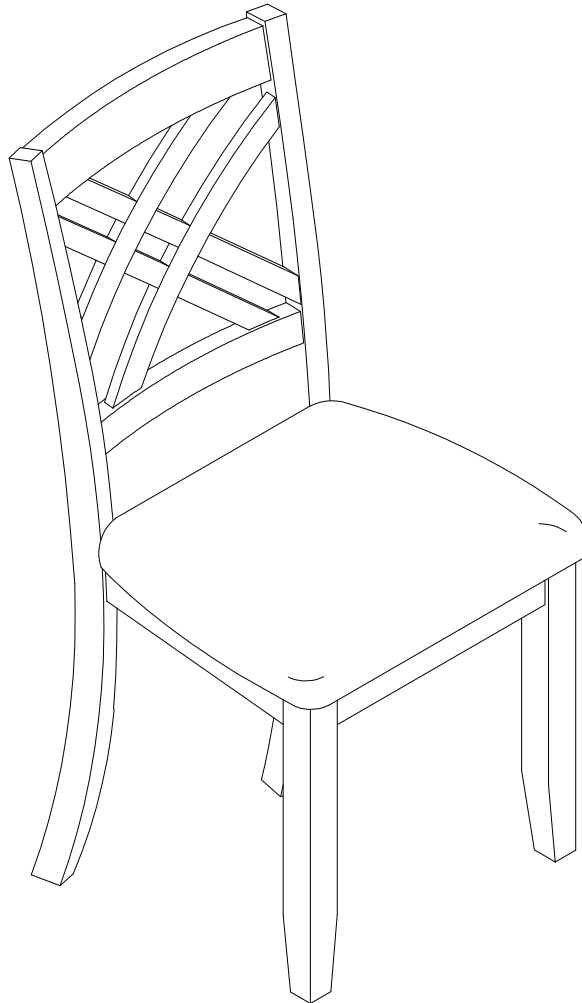

ITEM NO. FB3067HAY-SC-2PK







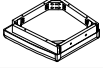

ASSEMBLY TIPS:

1. Remove hardware from box and sort by size.
2. Please check to see that all hardware and parts are present prior to start of assembly.
3. Please follow attached instructions in the same sequence as numbered to assure fast & easy assembly.

Part List

NO.	DIAGRAM	PART NAME	Q'ty
#1		Back frame with cushion	1pc x2
#2		Seat frame with cushion	1pc x2
#3		Front Legs	2pcs x2

Part List

NO.	DIAGRAM	PART NAME	Q'ty
#A		Bolt 1/4" x 3"	4pcs x2
#B		Bolt 1/4" x 2-3/8"	4pcs x2
#C		Bolt 1/4" x 1-1/2"	2pcs x2
#D		Spring washer Ø1/4"	10pcs x2
#E		Flat washer Ø1/4"	10pcs x2
#F		Allen key M4	1pc x2

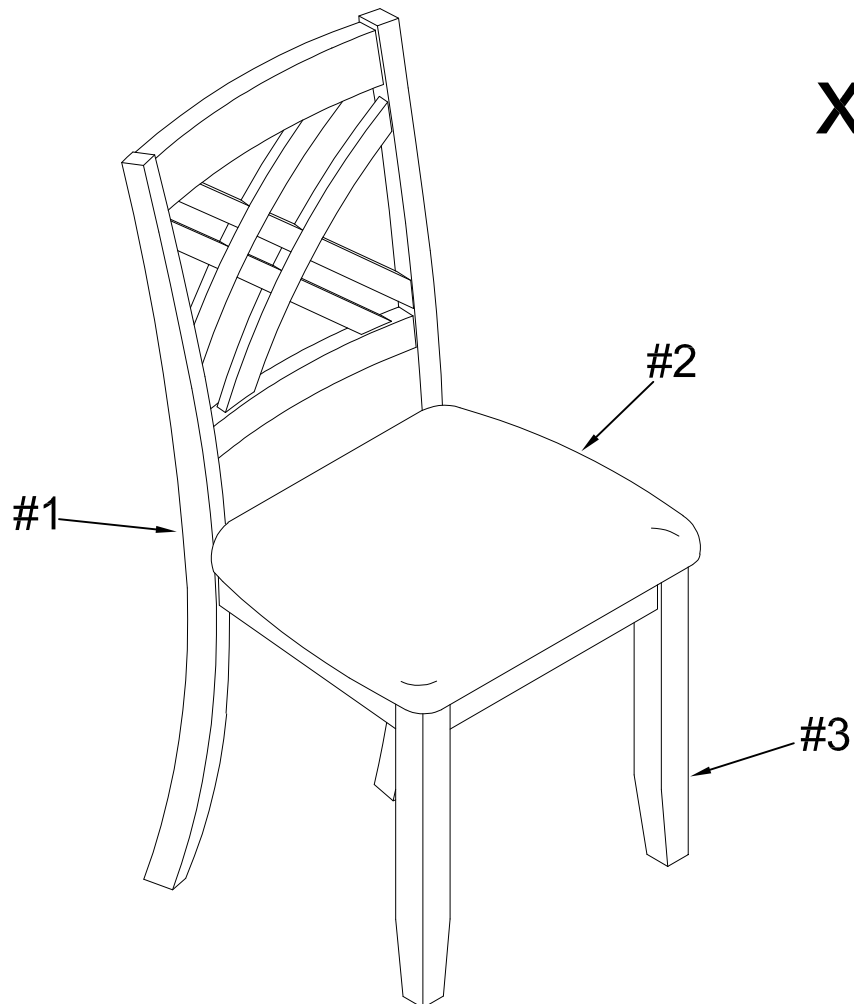

STEP 1:

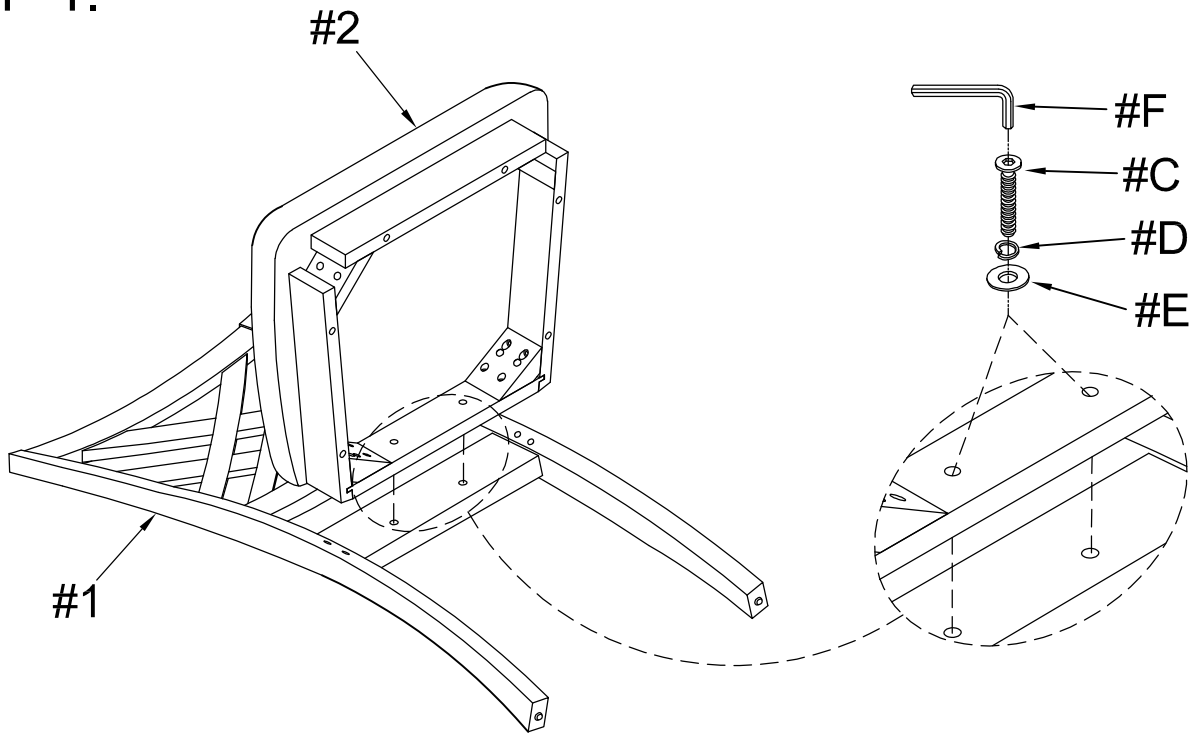

STEP 2:

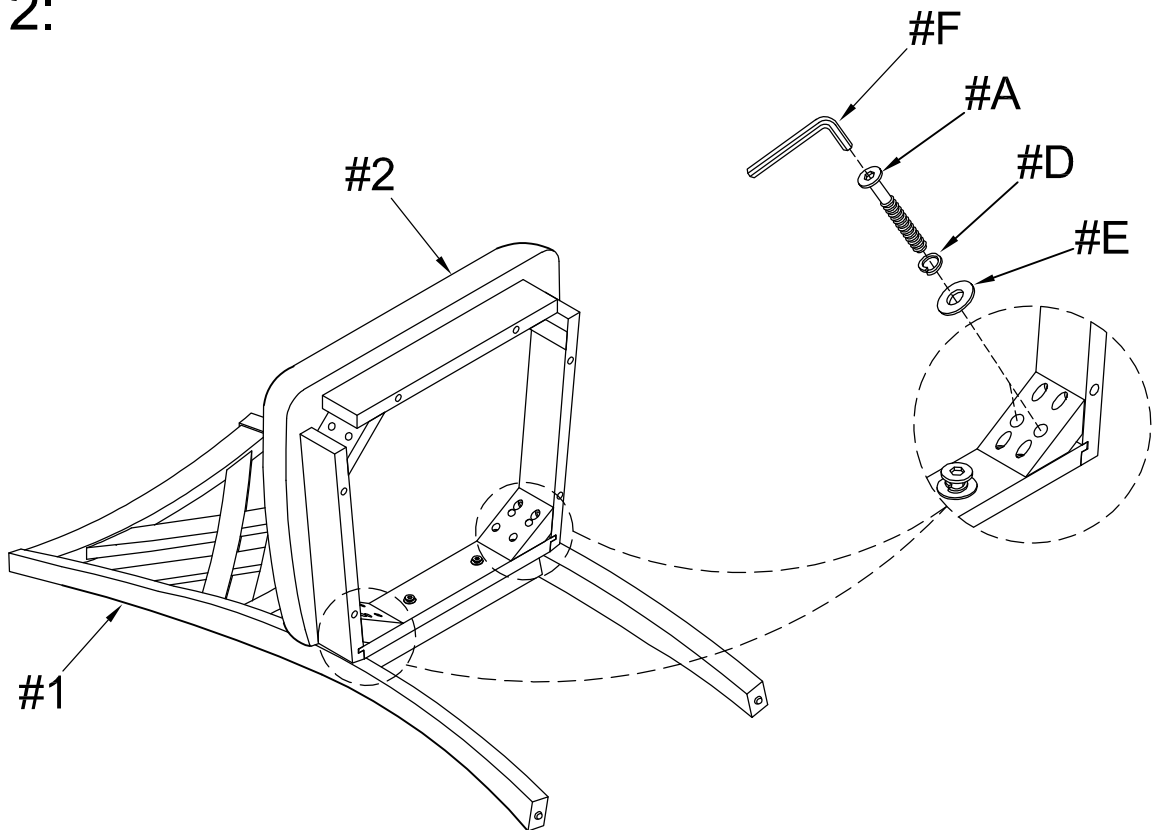

Do not tighten screws until completely assembled.

STEP 3:

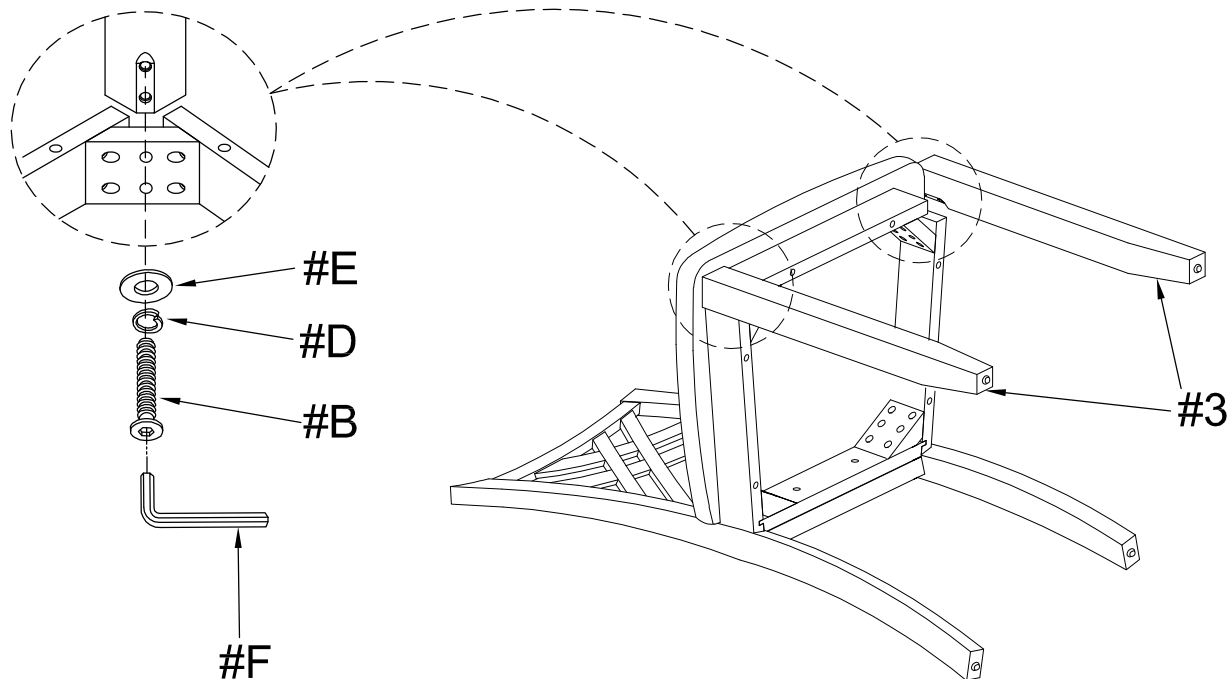

STEP 4:

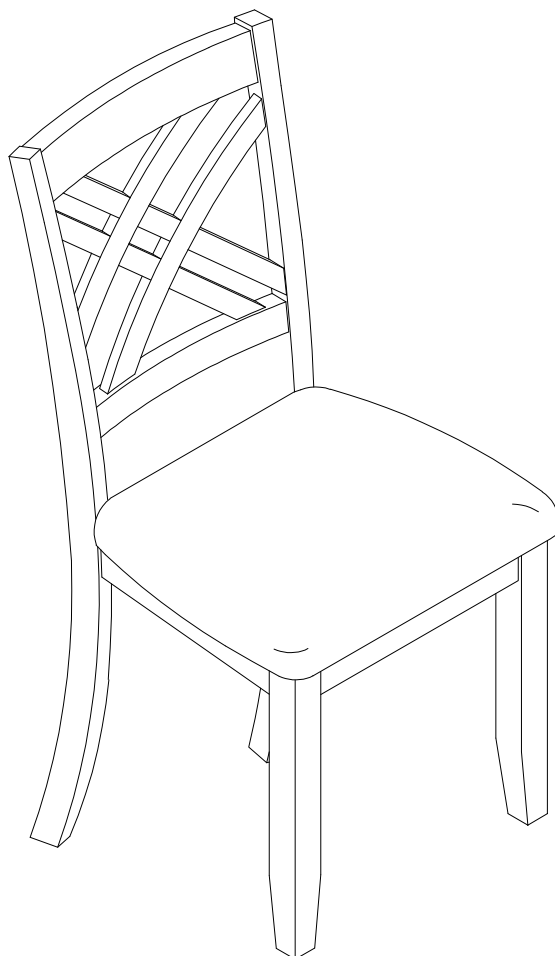

Tighten all screws until completely assembled.

ASSEMBLY INSTRUCTIONS

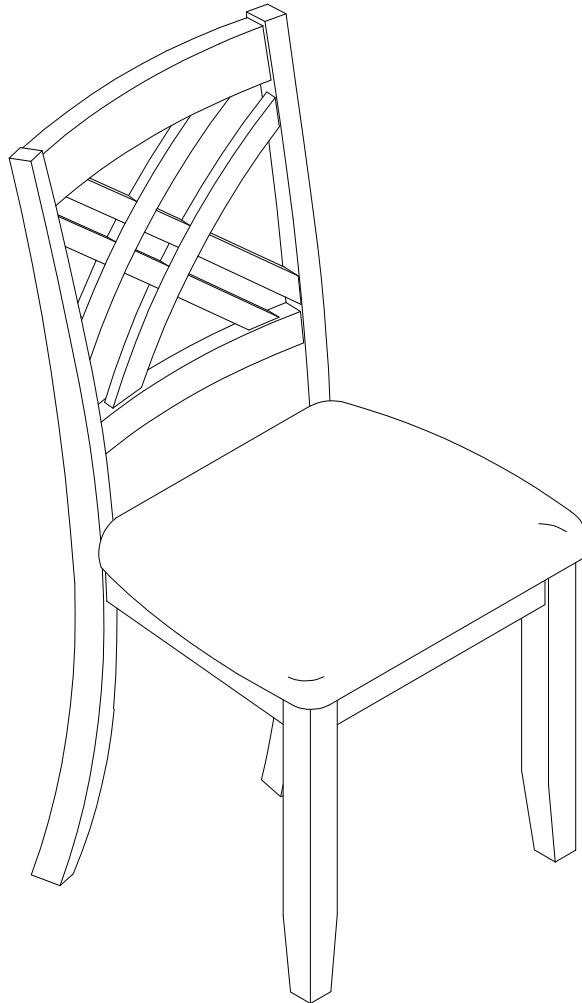

ITEM NO. FB3067HAY-SC-4PK







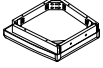

ASSEMBLY TIPS:

1. Remove hardware from box and sort by size.
2. Please check to see that all hardware and parts are present prior to start of assembly.
3. Please follow attached instructions in the same sequence as numbered to assure fast & easy assembly.

Part List

NO.	DIAGRAM	PART NAME	Q'ty
#1		Back frame	1pc x4
#2		Seat frame with cushion	1pc x4
#3		Front Legs	2pcs x4

Part List

NO.	DIAGRAM	PART NAME	Q'ty
#A		Bolt 1/4" x 3"	4pcs x4
#B		Bolt 1/4" x 2-3/8"	4pcs x4
#C		Bolt 1/4" x 1-1/2"	2pcs x4
#D		Spring washer Ø1/4"	10pcs x4
#E		Flat washer Ø1/4"	10pcs x4
#F		Allen key M4	1pc x4

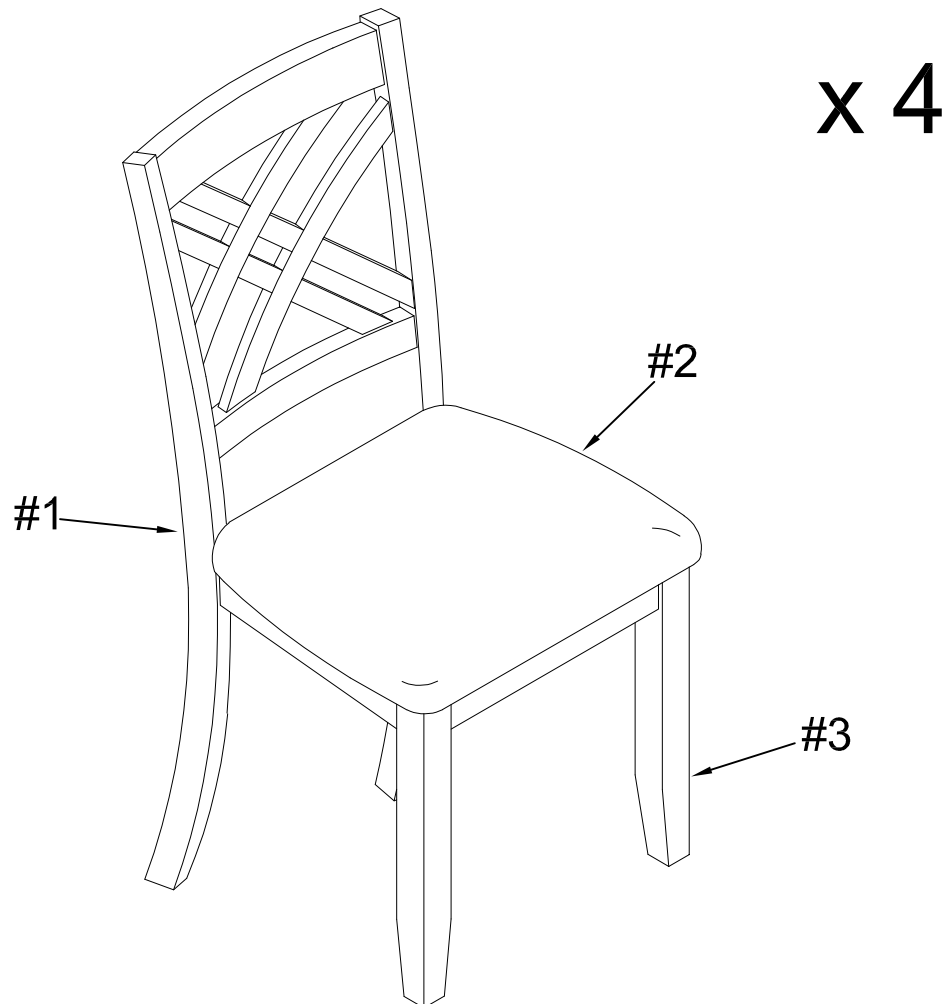

STEP 1:

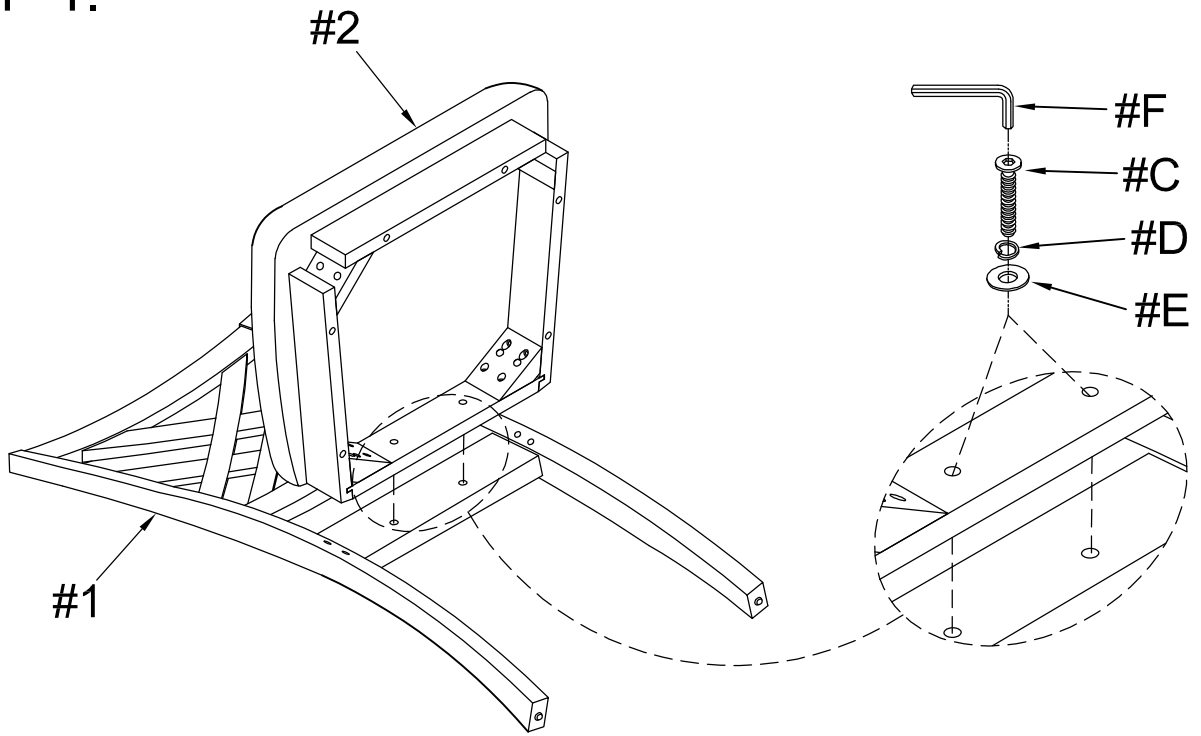

STEP 2:

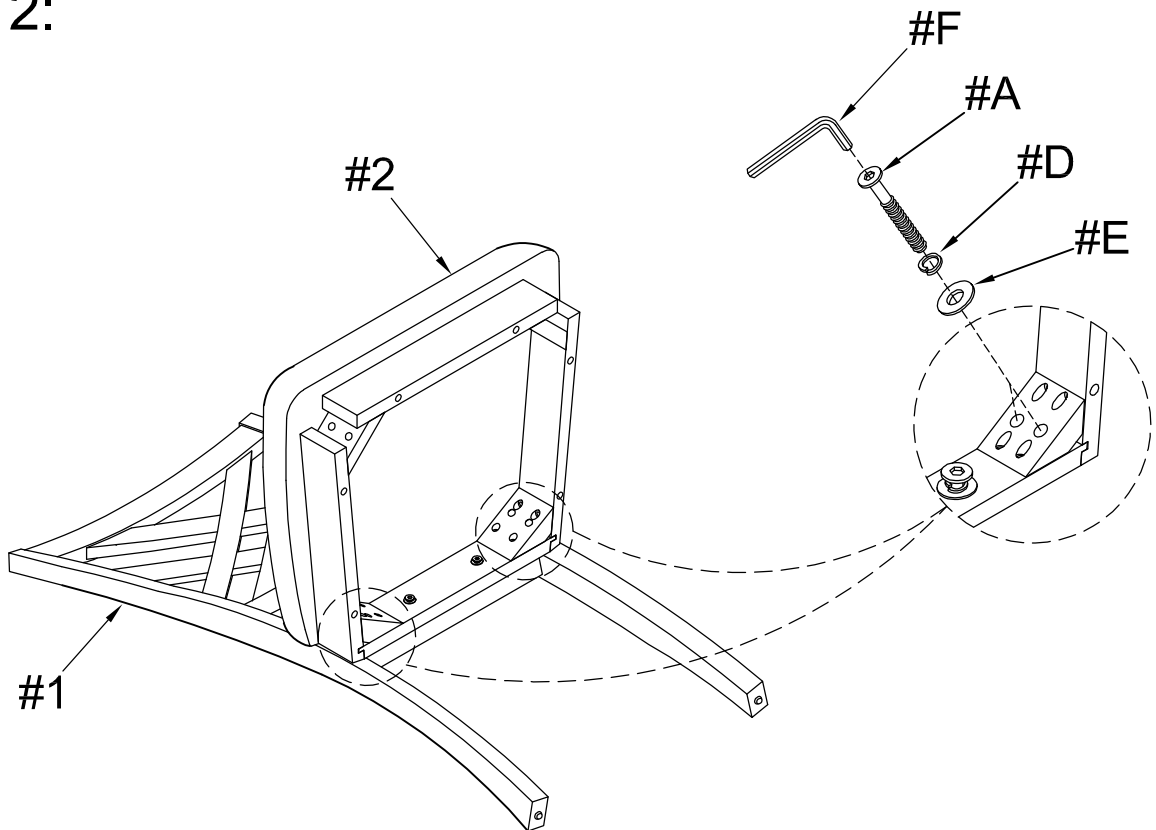

Do not tighten screws until completely assembled.

STEP 3:

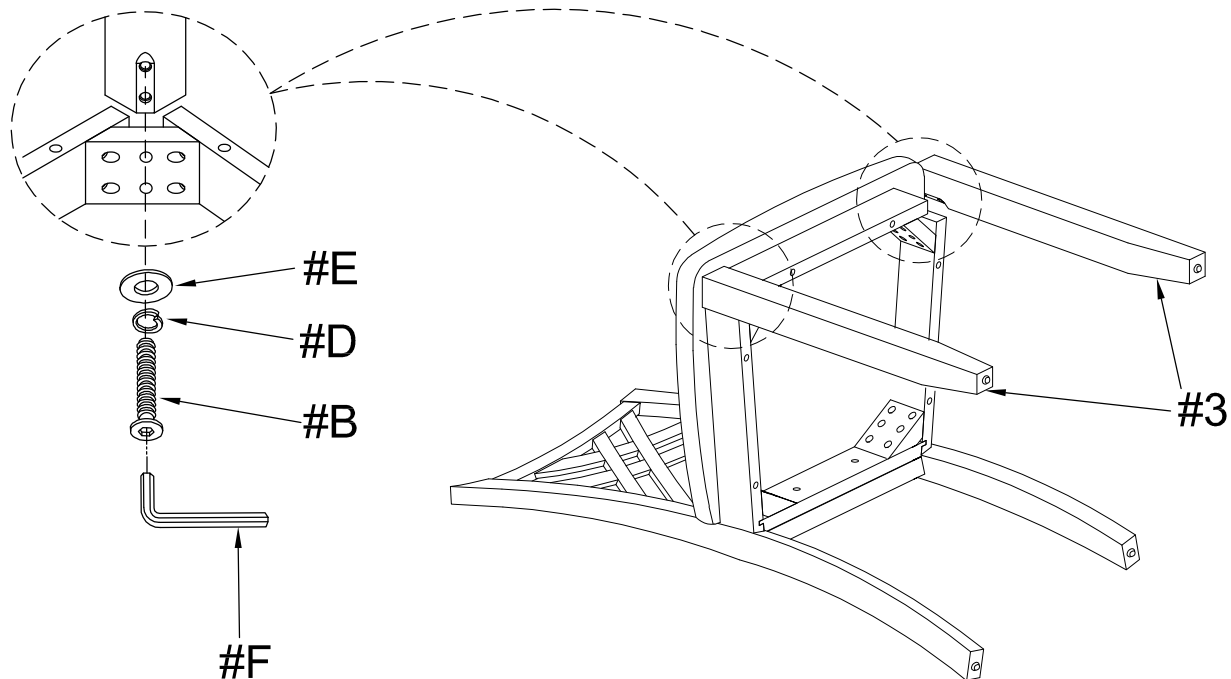

STEP 4:

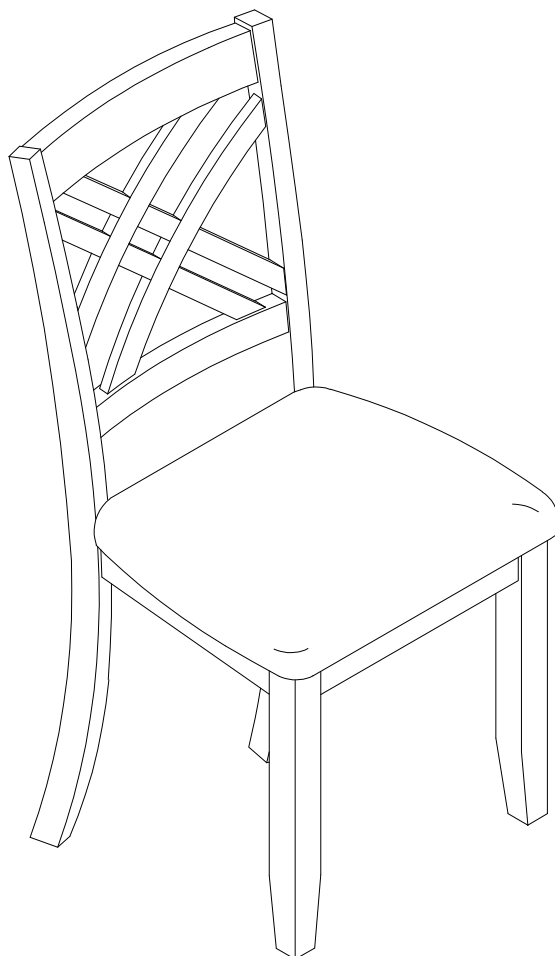

Tighten all screws until completely assembled.