

ASSEMBLY INSTRUCTION

TWIN CAR BED
WF294534

PAGE: 1 OF 6

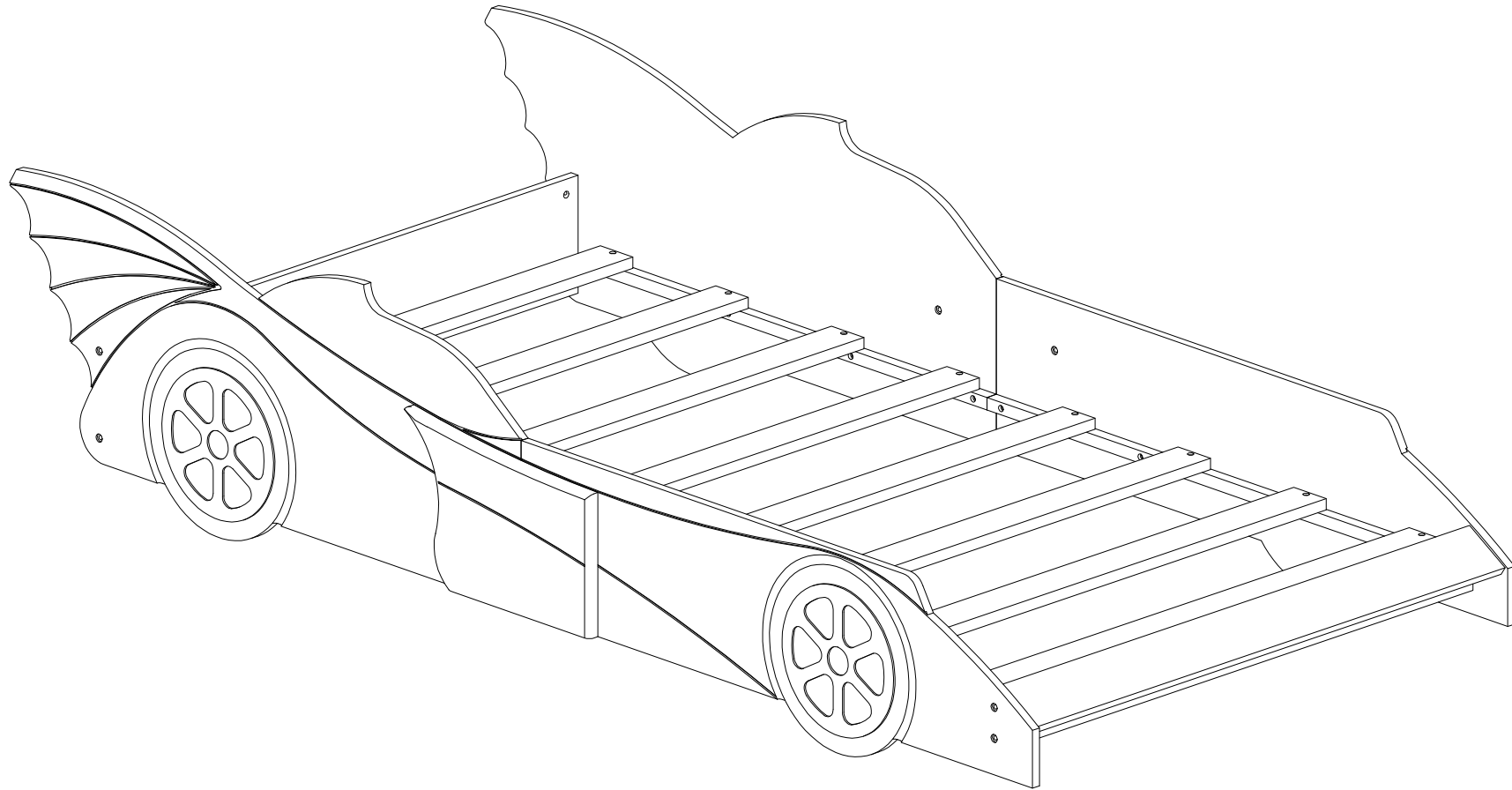

IMPORTANT NOTE

1. PLACE ALL PARTS ON A CLEAN AND SMOOTH SURFACE SUCH AS A RUG OR CARPET TO AVOID THE PARTS FROM BEING SCRATCHED
2. BEFORE YOU BEGIN, KINDLY FOLLOW THE ASSEMBLY INSTRUCTIONS STEP BY STEP
3. DO NOT TIGHTEN ALL SCREWS AND BOLTS UNTIL THE BED IS FULLY SET-UP

ASSEMBLY INSTRUCTION

PART LIST

HARDWARE LIST

AL

BACK SIDE RAIL LEFT
(1PC)

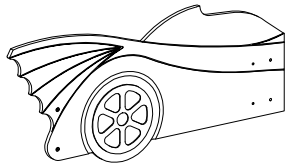

AR

BACK SIDE RAIL RIGHT
(1PC)

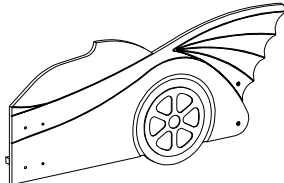

1

ALLEN KEY (1PC)
K4 x 60 mm

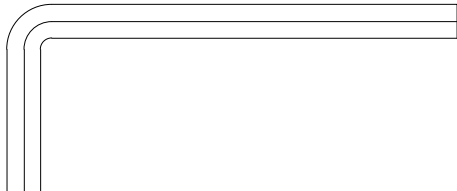

BL

FRONT SIDE RAIL LEFT
(1PC)

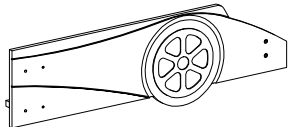

BR

FRONT SIDE RAIL RIGHT
(1PC)

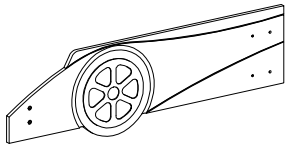

2

HEX HEAD BLOT (8PCS)
1/4 x 25 mm

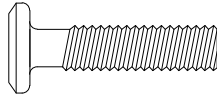

CL

SUPPORT SIDE RAIL LEFT
(1PC)

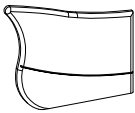

CR

SUPPORT SIDE RAIL LEFT
(1PC)

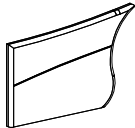

3

WOOD DOWEL (16PCS)
Ø8 x 25 mm

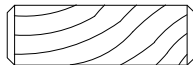

D

BACK RAIL (1PC)

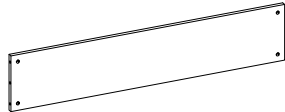

E

FRONT RAIL UPPER (1PC)

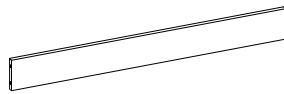

4

HEX HEAD BLOT (8PCS)
1/4 x 50 mm

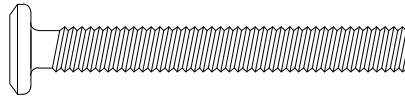

F

FRONT RAIL LOWER (1PC)

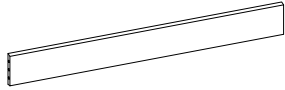

V

SLATS (8PCS)



5

BARREL NUT (8PCS)
1/4 x Ø10 x 10 mm



6

WOOD SCREW (16PCS)
Ø4 x 25 mm



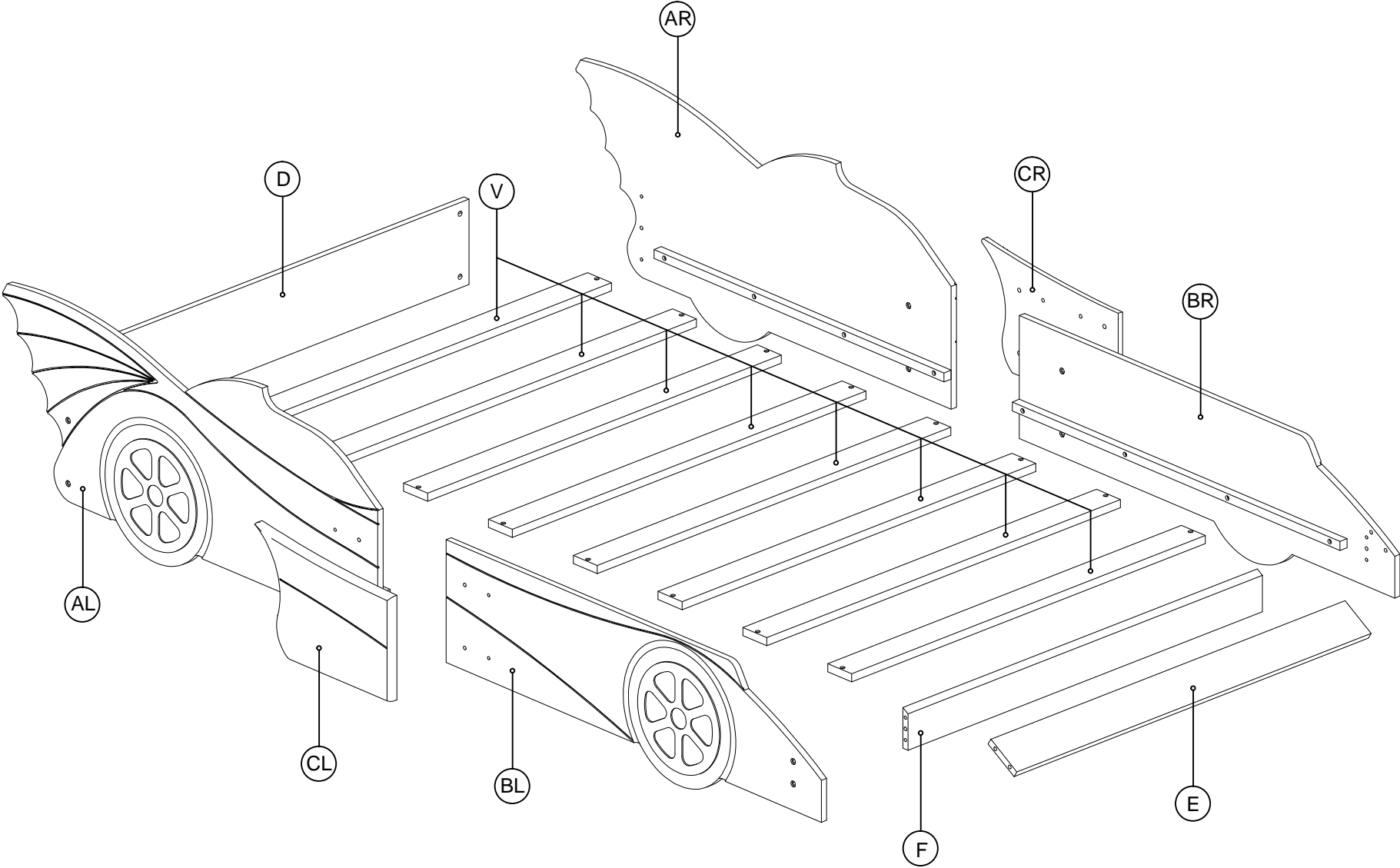

ASSEMBLY INSTRUCTION

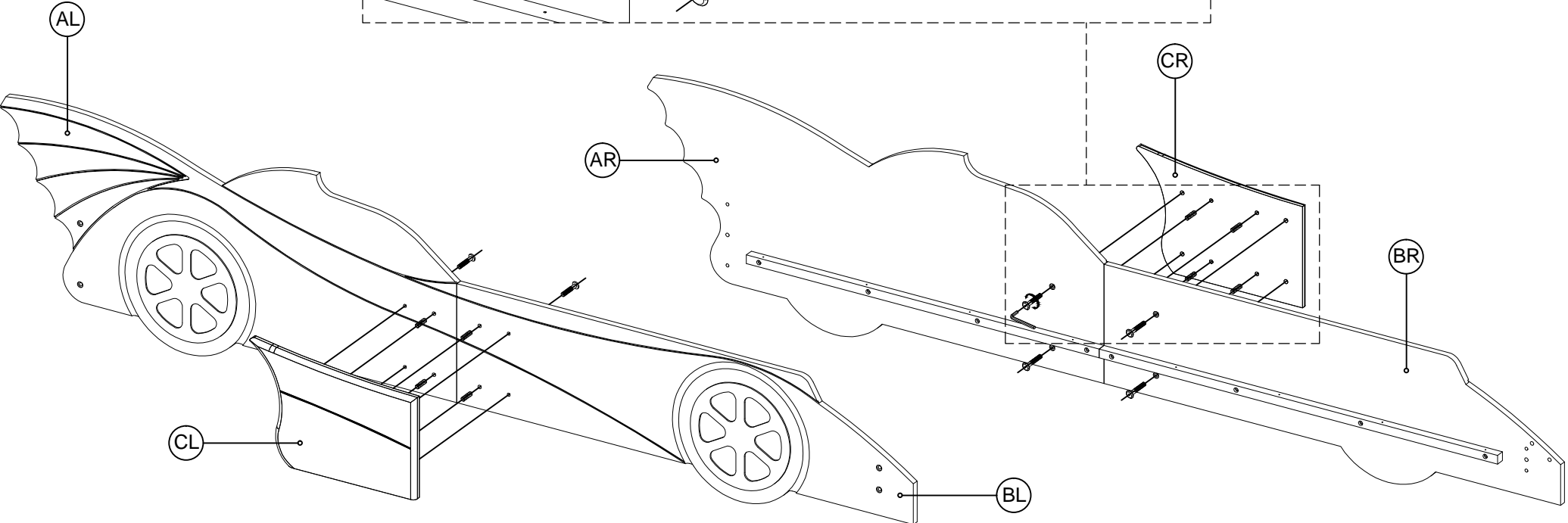
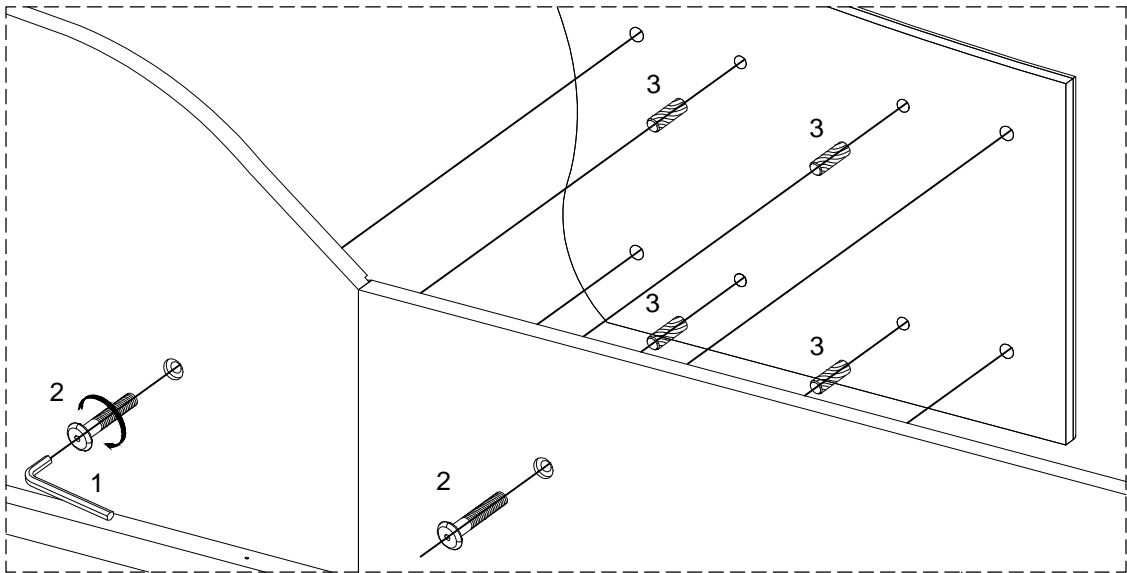

ASSEMBLY INSTRUCTION

STEP 1

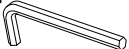
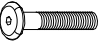



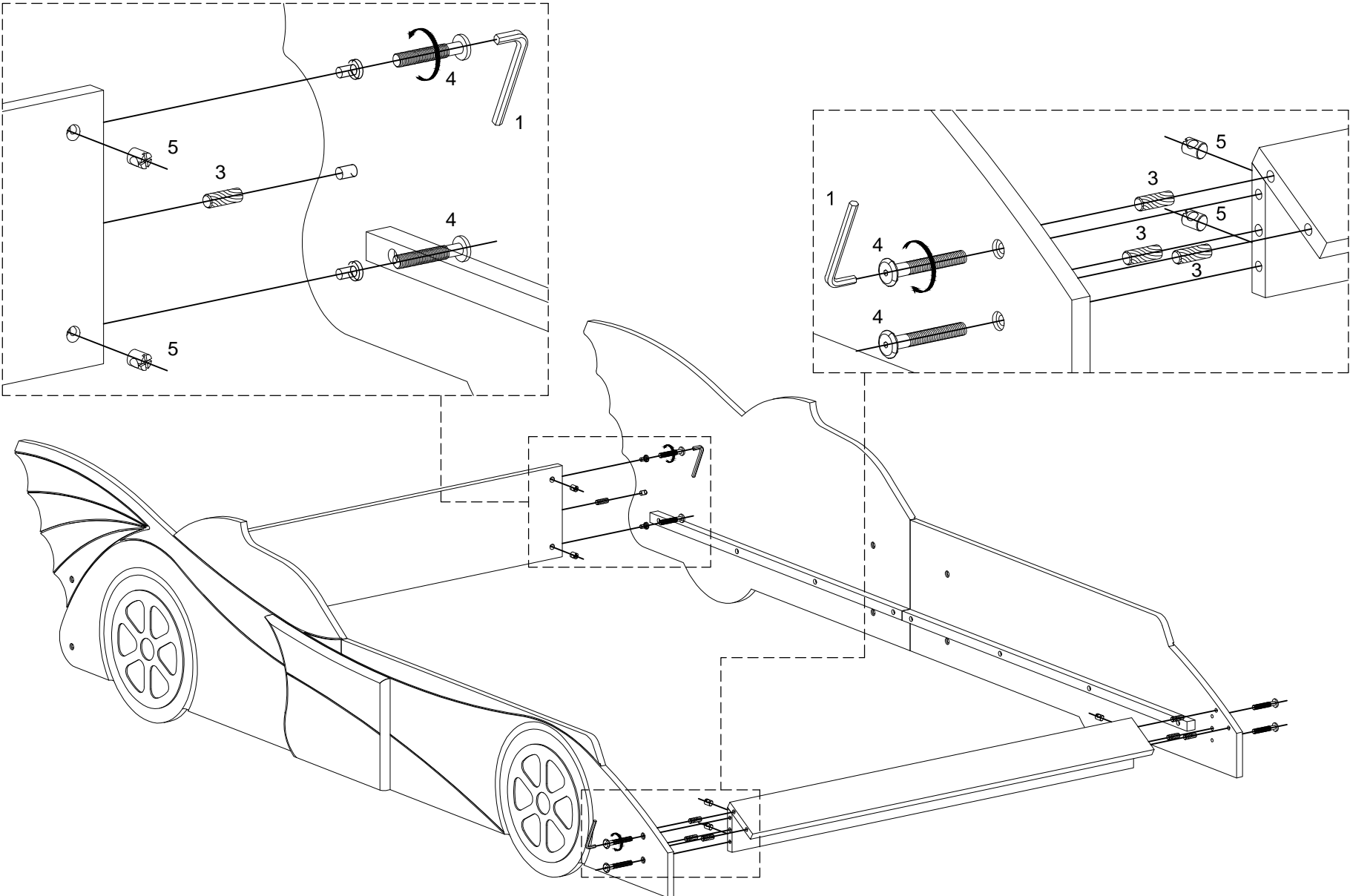

1		2		3	
	Allen key - 1pc K4 x 60 mm		Hex head blot - 8pcs 1/4 x 25 mm		Wood dowel - 8pcs Ø8 x 25 mm

ASSEMBLY INSTRUCTION

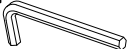
STEP 2



1		3		4		5	
	Allen key - 1pc K4 x 60 mm		Wood dowel - 8pcs Ø8 x 25 mm		Hex head blot - 8pcs 1/4 x 50 mm		Barrel nut - 8pcs 1/4 x Ø10 x 10 mm

ASSEMBLY INSTRUCTION

STEP 3

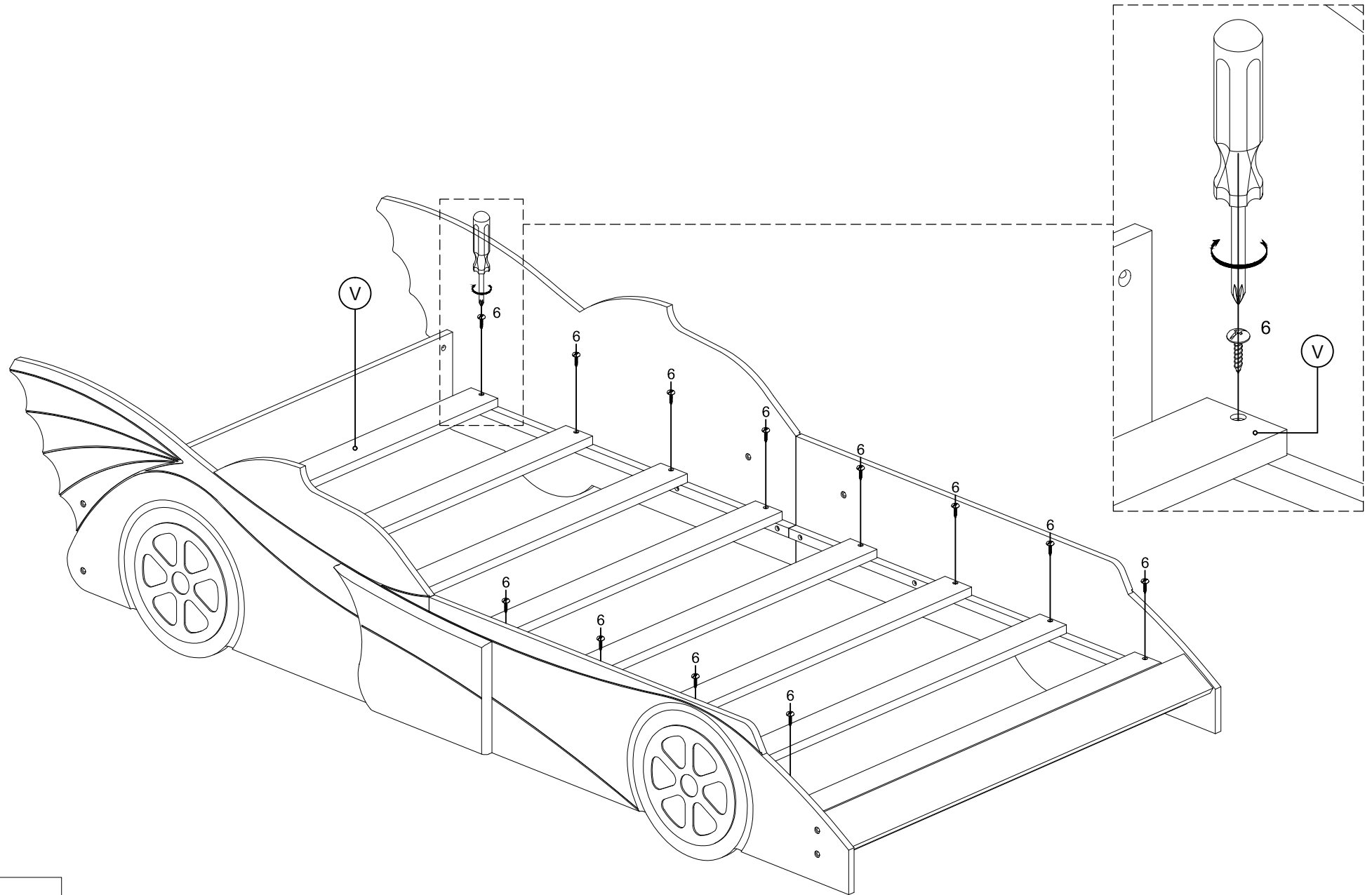

6

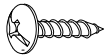

Wood screw - 16pcs
Ø4 x 25 mm