

ASSEMBLY INSTRUCTION

ITEM NO.N715P194626

Dining Table

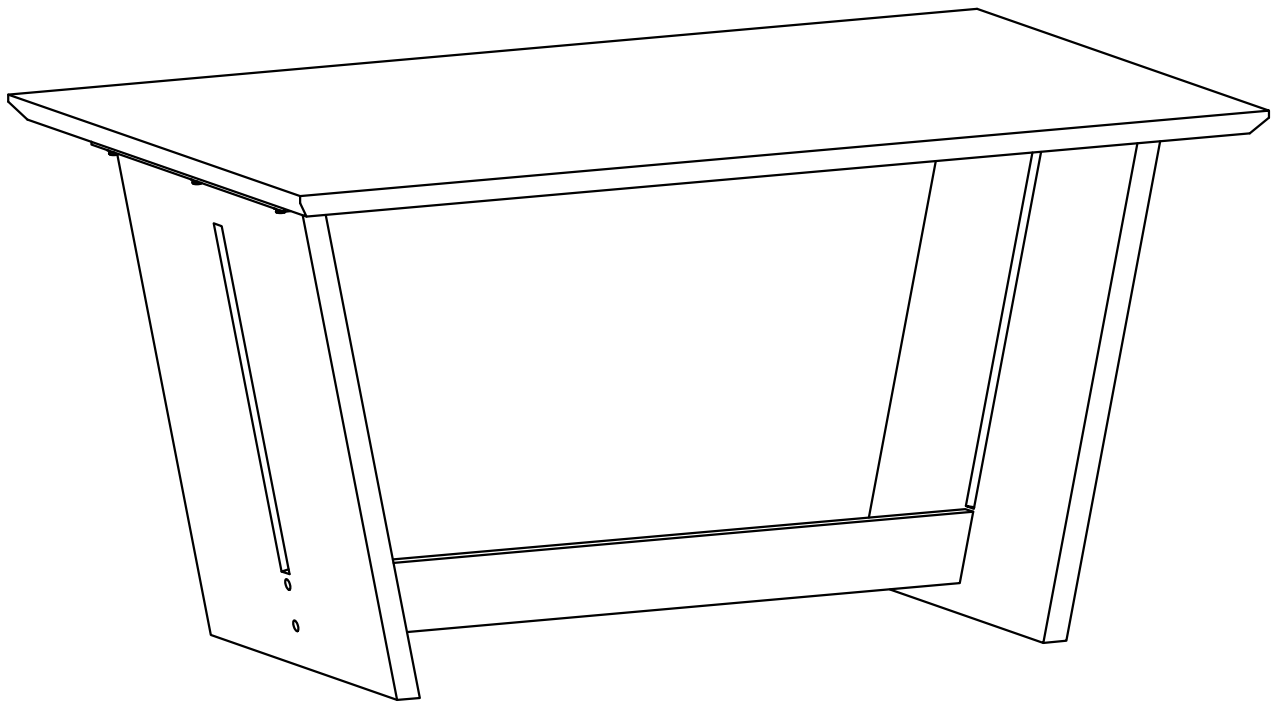

ASSEMBLY INSTRUCTION

ITEM NO.N715P194626

Please read these instructions fully before starting assembly:

1. Place all wooden parts on a clean and smooth surface such as a rug or carpet to avoid scratching the parts.
2. Kindly follow the assembly instructions step by step.
3. Do not tighten all screws and bolts until the stool is fully assembled.
4. Unscrew the protective plastique supports from the metal insert of the table legs before assembly.
5. Parts of the assembly will be easier with 2 people.

Care and maintenance:

Only clean using a damp cloth and mild detergent, do not use bleach or abrasive cleaners.

ASSEMBLY INSTRUCTION

ITEM NO.N715P194626

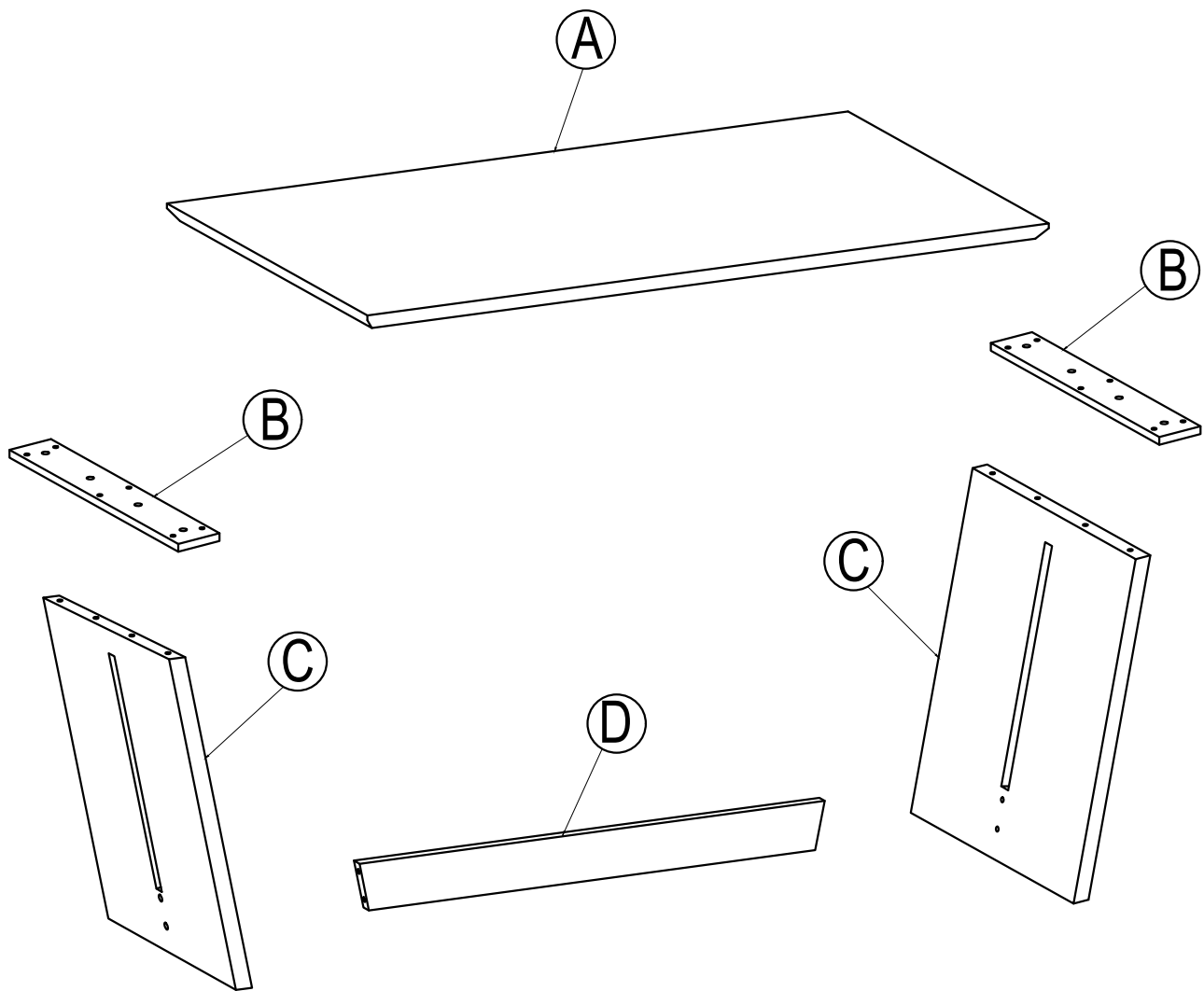

ASSEMBLY INSTRUCTION

ITEM NO.N715P194626

Part List

(A)

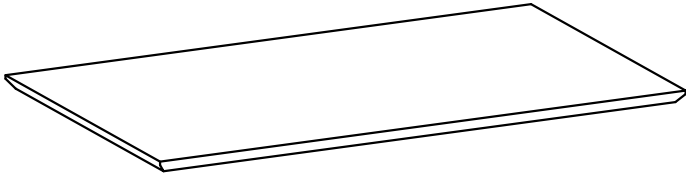
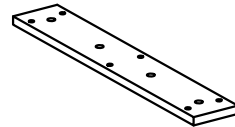

TABLE TOP (1 pc)

(B)



PANEL TOP LEG (2 pcs)

(C)

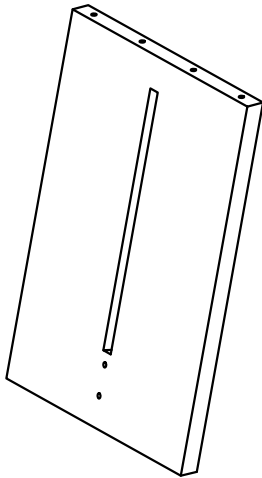

LEG (2 pcs)

(D)



STRETCHER (1 pc)

ASSEMBLY INSTRUCTION

ITEM NO.N715P194626

Hardware List

①

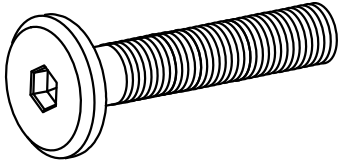

Ø 5/16" x 35 mm

BOLT (20 pcs)

②

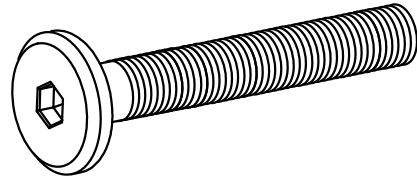

Ø 5/16" x 50 mm

BOLT (4 pcs)

③

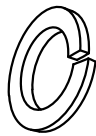

Ø5/16" x 13 mm

FLAT WASHER (24 pcs)

④

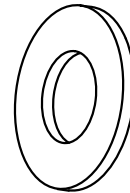

Ø5/16" x 19 mm

LOCK WASHER (12 pcs)

⑤



4 mm

ALLEN KEY (1 pc)

⑥







WOOD PLUG (4 pcs)

ASSEMBLY INSTRUCTION

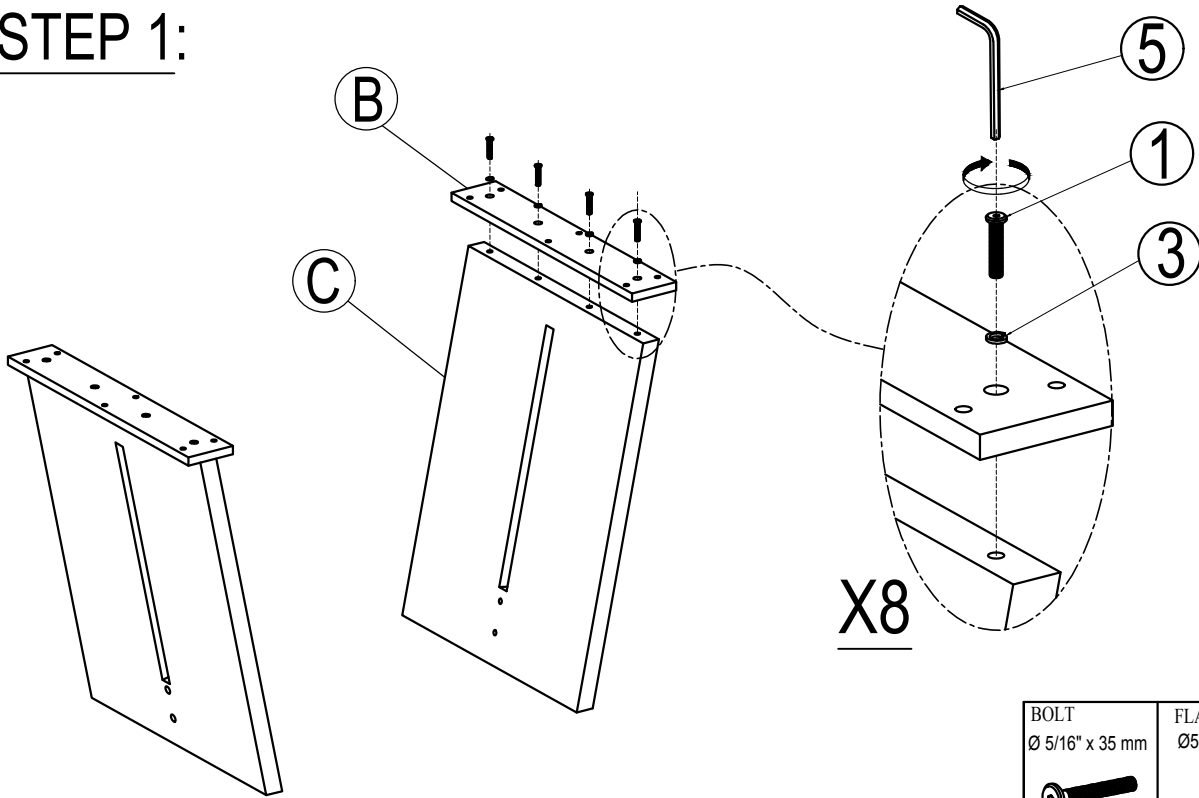
ITEM NO.N715P194626



STEP 1:

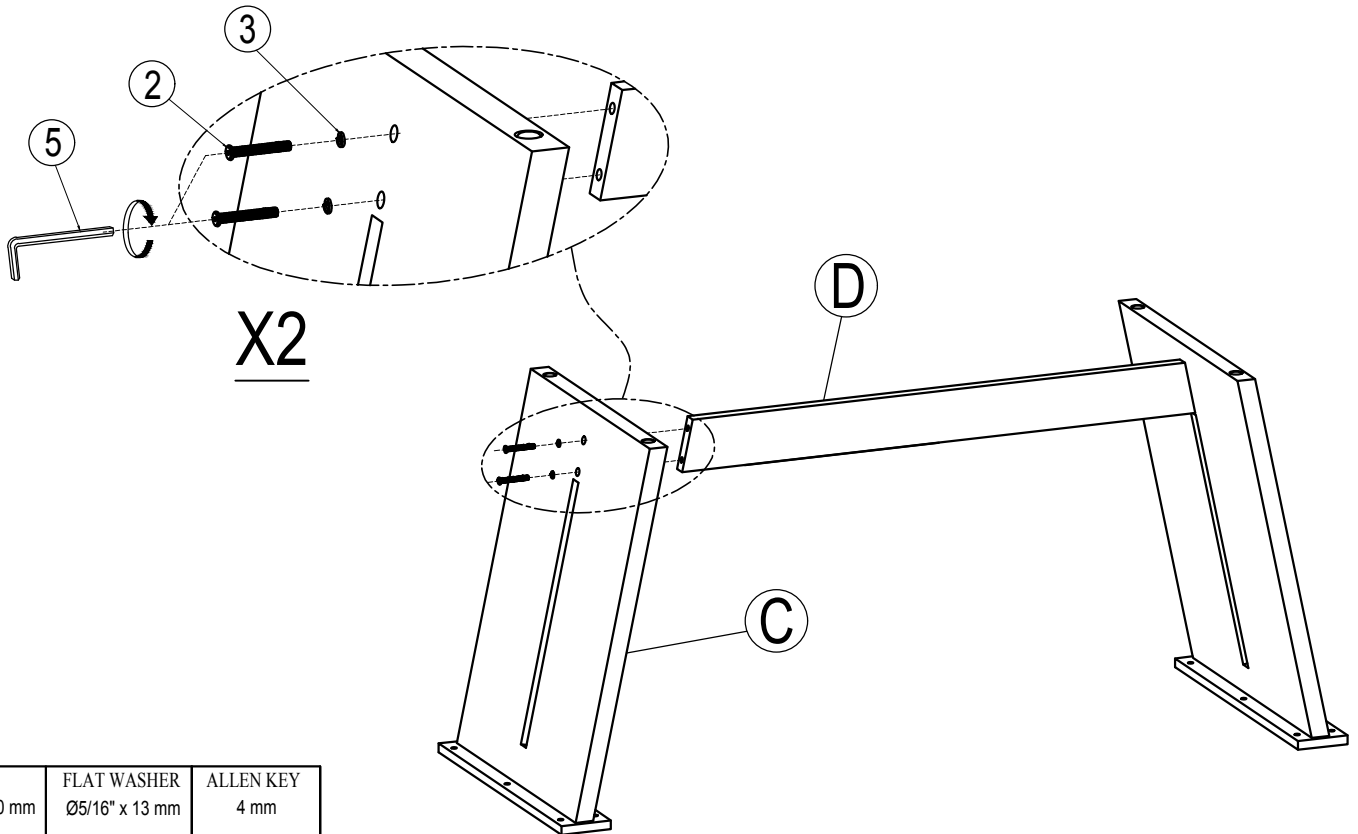

BOLT Ø 5/16" x 35 mm	FLAT WASHER Ø5/16" x 13 mm	ALLEN KEY 4 mm
		
① x 8	③ x 8	⑤ x 1

STEP 2:







BOLT Ø 5/16" x 50 mm	FLAT WASHER Ø5/16" x 13 mm	ALLEN KEY 4 mm
		
② x 4	③ x 4	⑤ x 1

ASSEMBLY INSTRUCTION

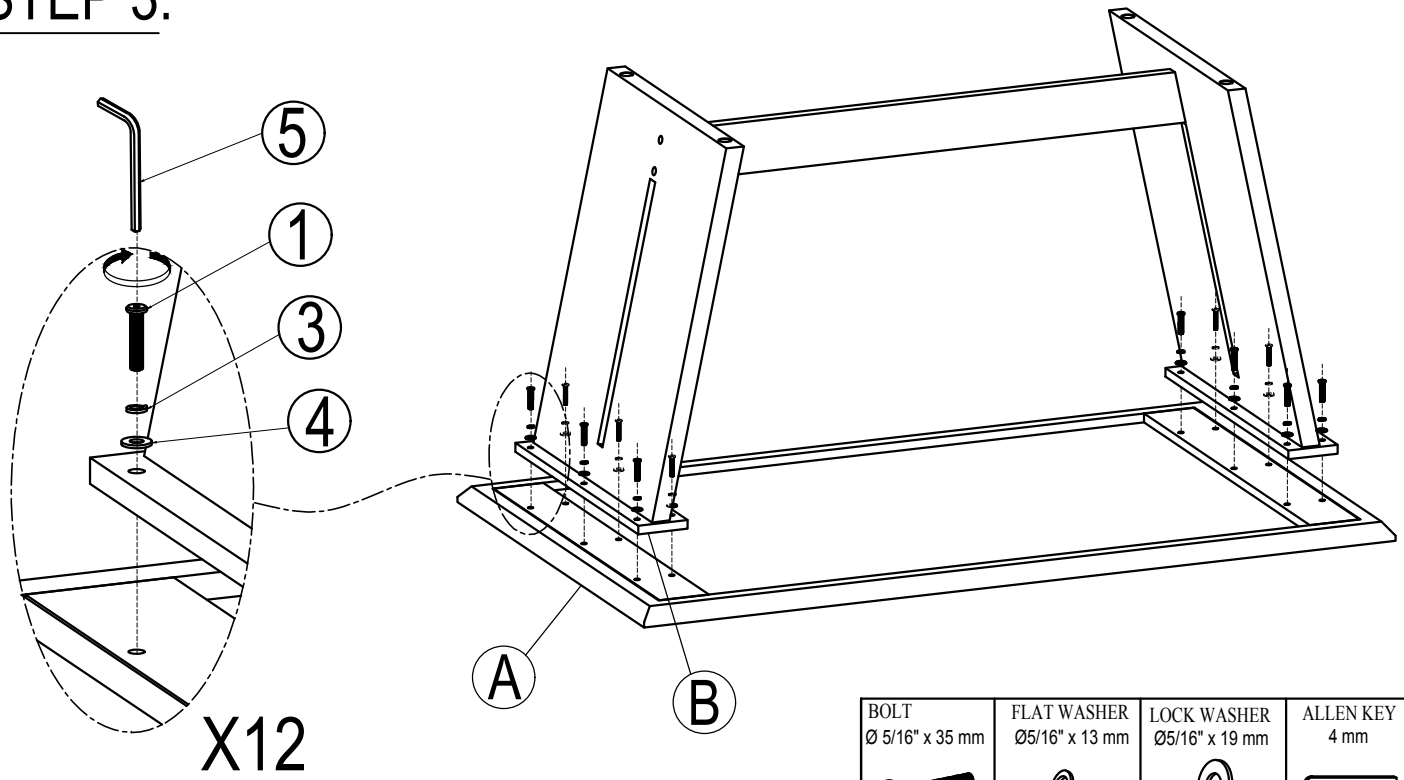
ITEM NO.N715P194626

STEP 3:

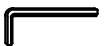

BOLT Ø 5/16" x 35 mm	FLAT WASHER Ø5/16" x 13 mm	LOCK WASHER Ø5/16" x 19 mm	ALLEN KEY 4 mm
			
① x 12	③ x 12	④ x 12	⑤ x 1

COMPLETE

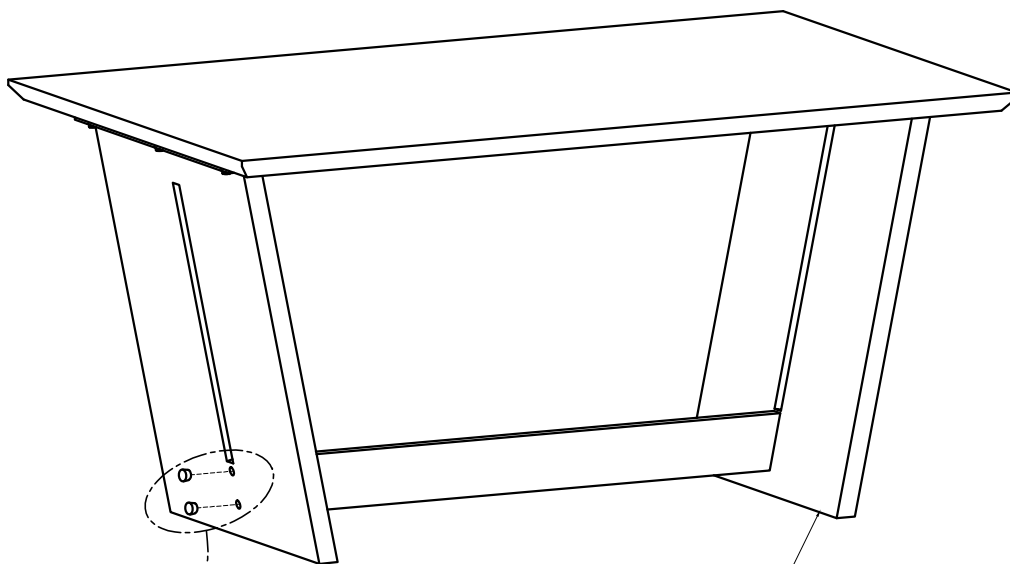

WOOD PLUG

⑥ x 4

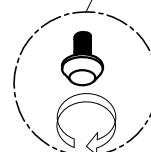
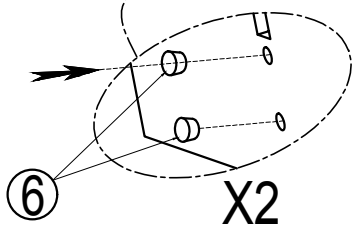

Adjust Leveler = 4 pcs

ASSEMBLY INSTRUCTION

ITEM NO.N715P194627

Dining Chair

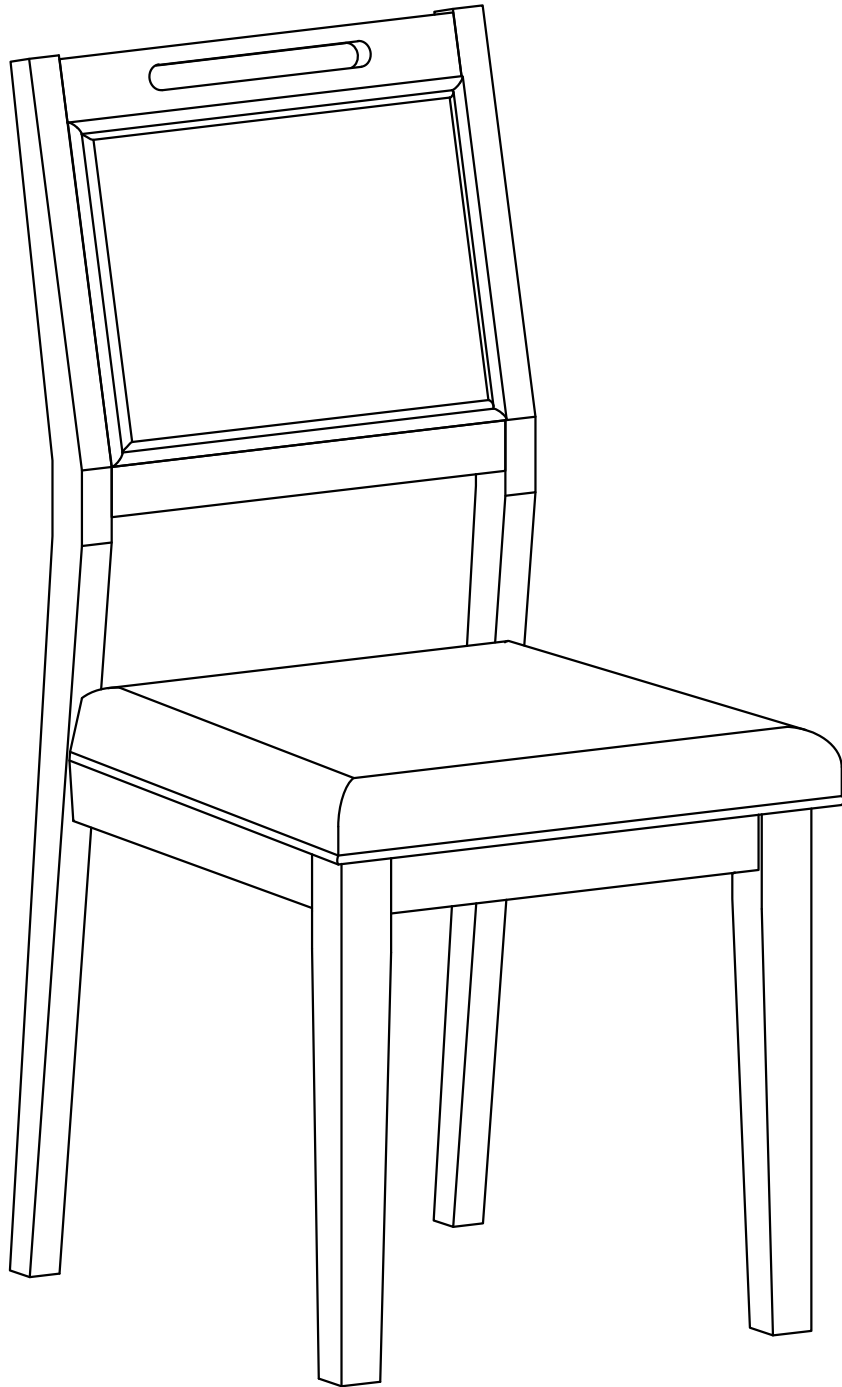

ASSEMBLY INSTRUCTION

ITEM NO.N715P194627

Please read these instructions fully before starting assembly:

1. Place all wooden parts on a clean and smooth surface such as a rug or carpet to avoid scratching the parts.
2. Kindly follow the assembly instructions step by step.
3. Do not tighten all screws and bolts until the table is fully assembled.
4. Unscrew the protective plastique supports from the metal insert of the table legs before assembly.
5. Parts of the assembly will be easier with 2 people.

Care and maintenance:

Only clean using a damp cloth and mild detergent, do not use bleach or abrasive cleaners.

ASSEMBLY INSTRUCTION

ITEM NO.N715P194627

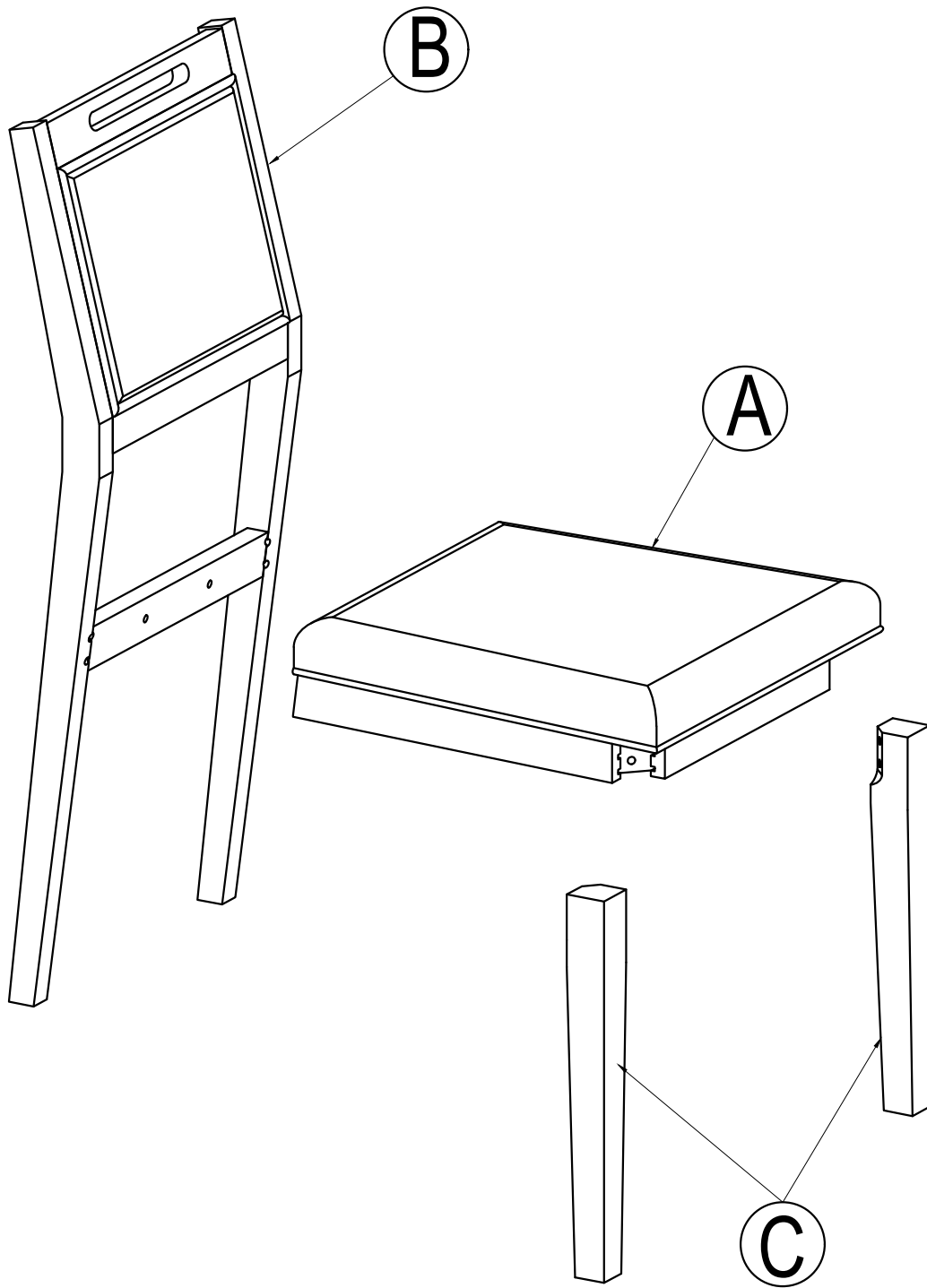

ASSEMBLY INSTRUCTION

ITEM NO.N715P194627

Part List

Ⓐ

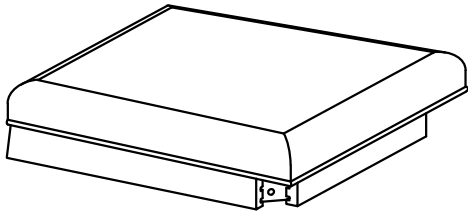

CUSHION SEAT (4 pcs)

Ⓑ

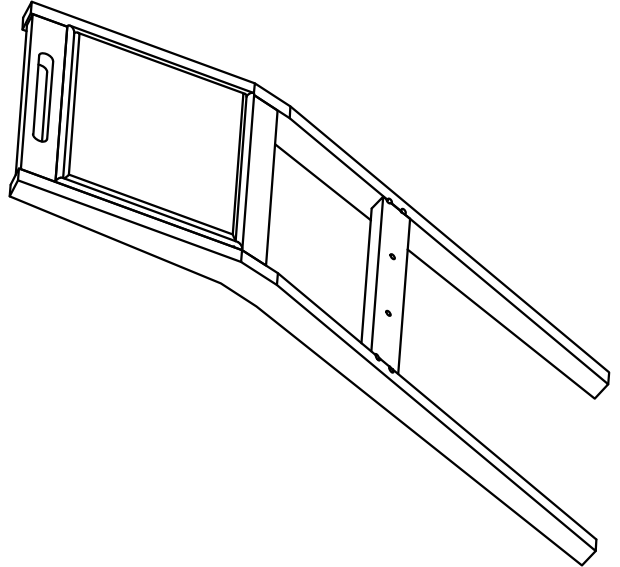

CHAIR BACK (4 pcs)

Ⓒ

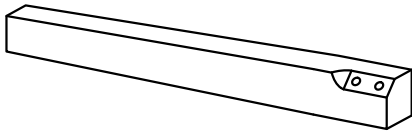

FRONT LEGS (8 pcs)

ASSEMBLY INSTRUCTION

ITEM NO.N715P194627

Hardware List

①

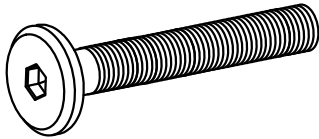

Ø 1/4" x 40mm

BOLT (8pcs)

②

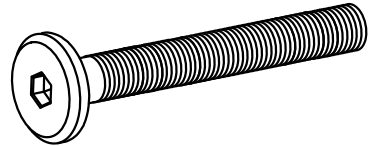

Ø 1/4" x 55mm

BOLT (16 pcs)

③

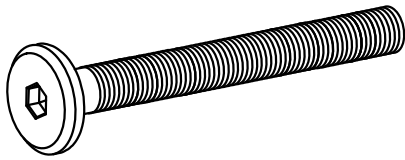

Ø 1/4" x 75mm

BOLT (16 pcs)

④

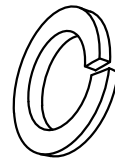

Ø5/16" x 13mm

FLAT WASHER (40 pcs)

⑤

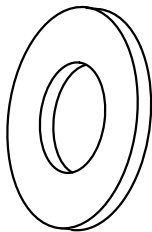

Ø5/16" x 19mm

LOCK WASHER (40 pcs)

⑥



4mm





ALLEN KEY (1pc)

ASSEMBLY INSTRUCTION

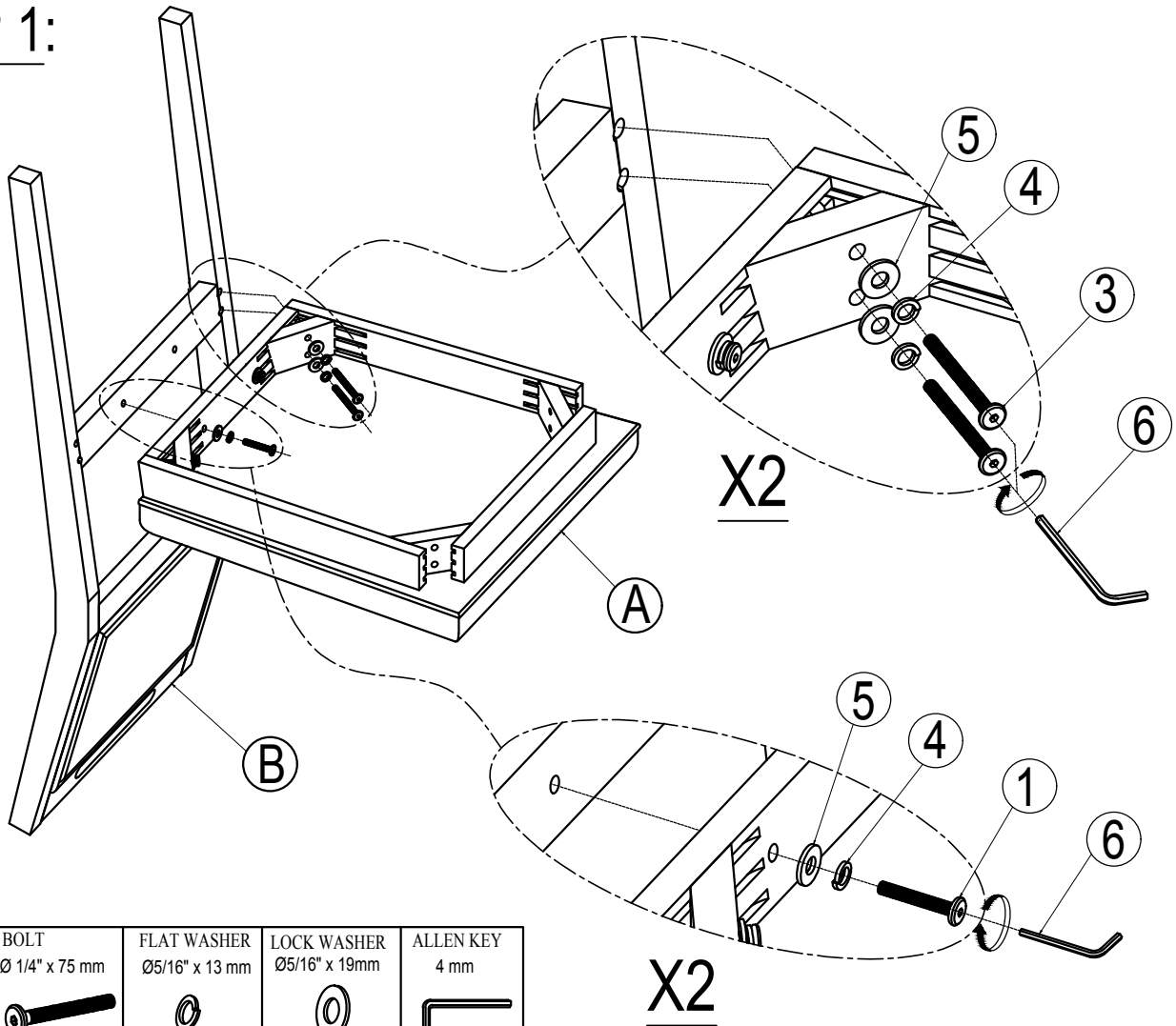
ITEM NO.N715P194627





STEP 1:

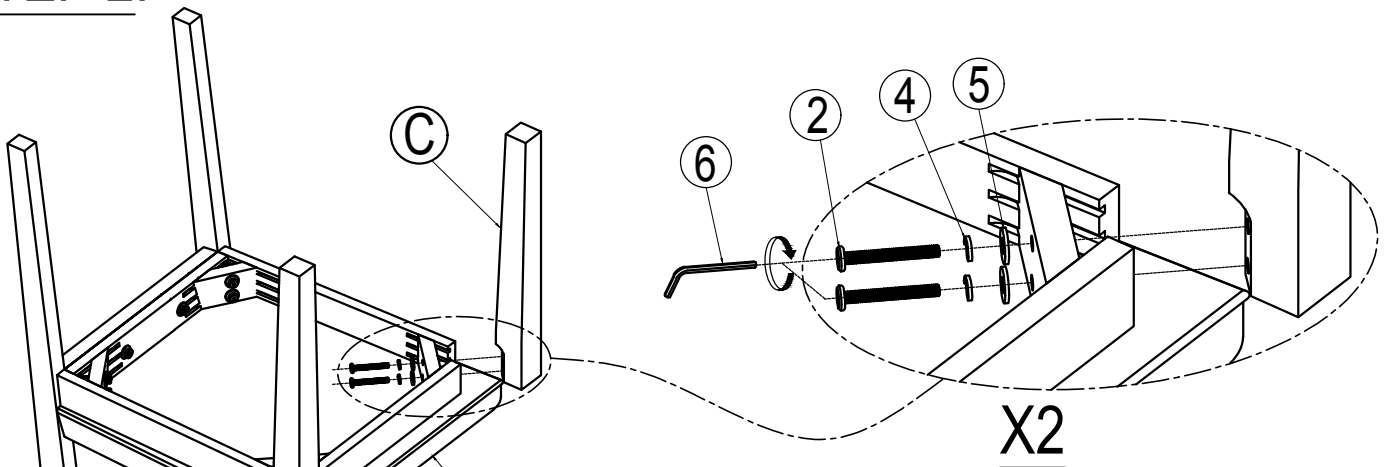

BOLT Ø 1/4" x 40 mm	BOLT Ø 1/4" x 75 mm	FLAT WASHER Ø5/16" x 13 mm	LOCK WASHER Ø5/16" x 19mm	ALLEN KEY 4 mm
				
①x 2	③x 4	④x 6	⑤x 6	⑥x 1

STEP 2:



BOLT Ø 1/4" x 55 mm	FLAT WASHER Ø5/16" x 13 mm	LOCK WASHER Ø5/16" x 19mm	ALLEN KEY 4 mm
			
②x 4	④x 4	⑤x 4	⑥x 1

ASSEMBLY INSTRUCTION

ITEM NO.N715P194627

COMPLETE

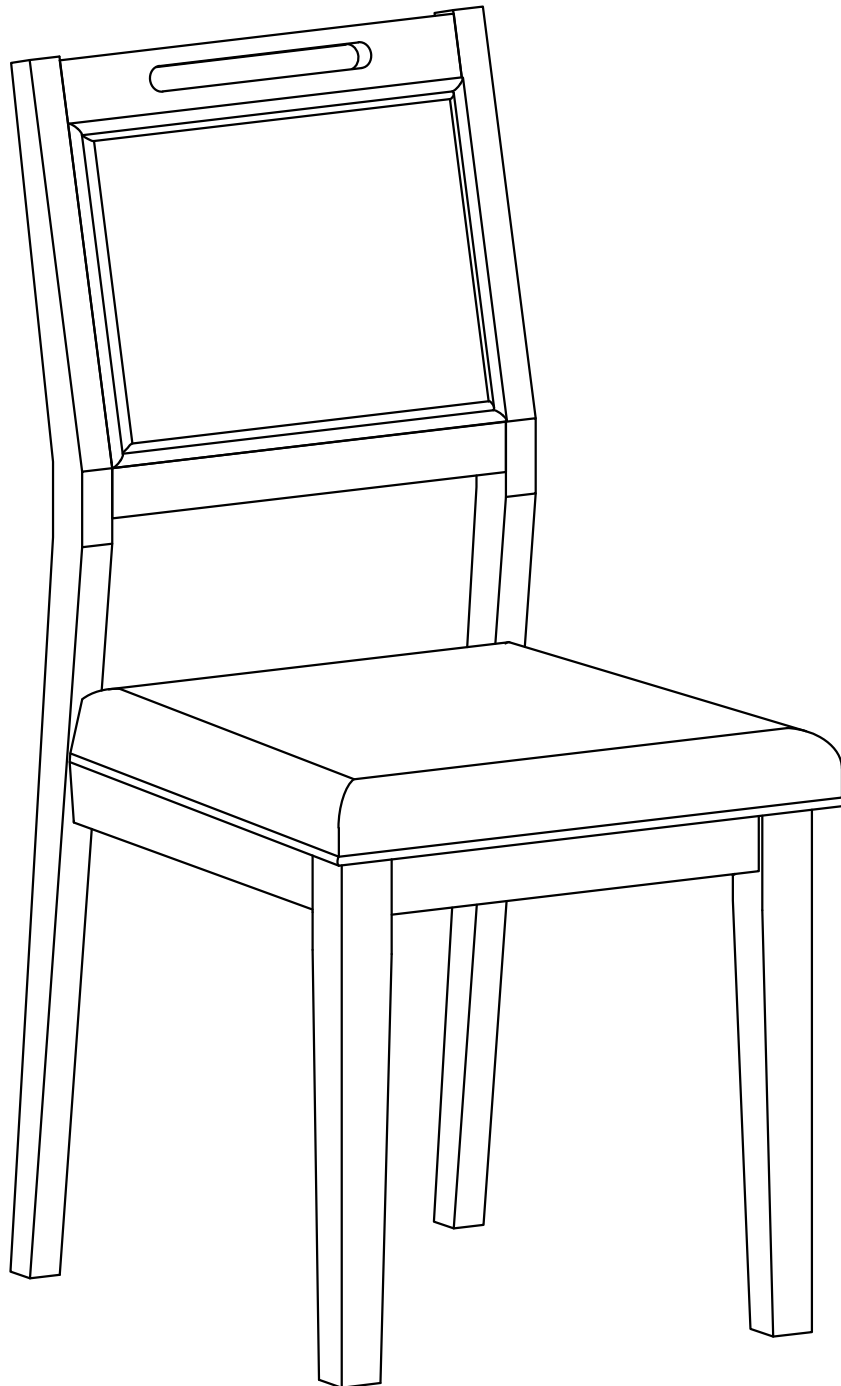

ASSEMBLY INSTRUCTION

ITEM NO.N715P194628

Dining Bench

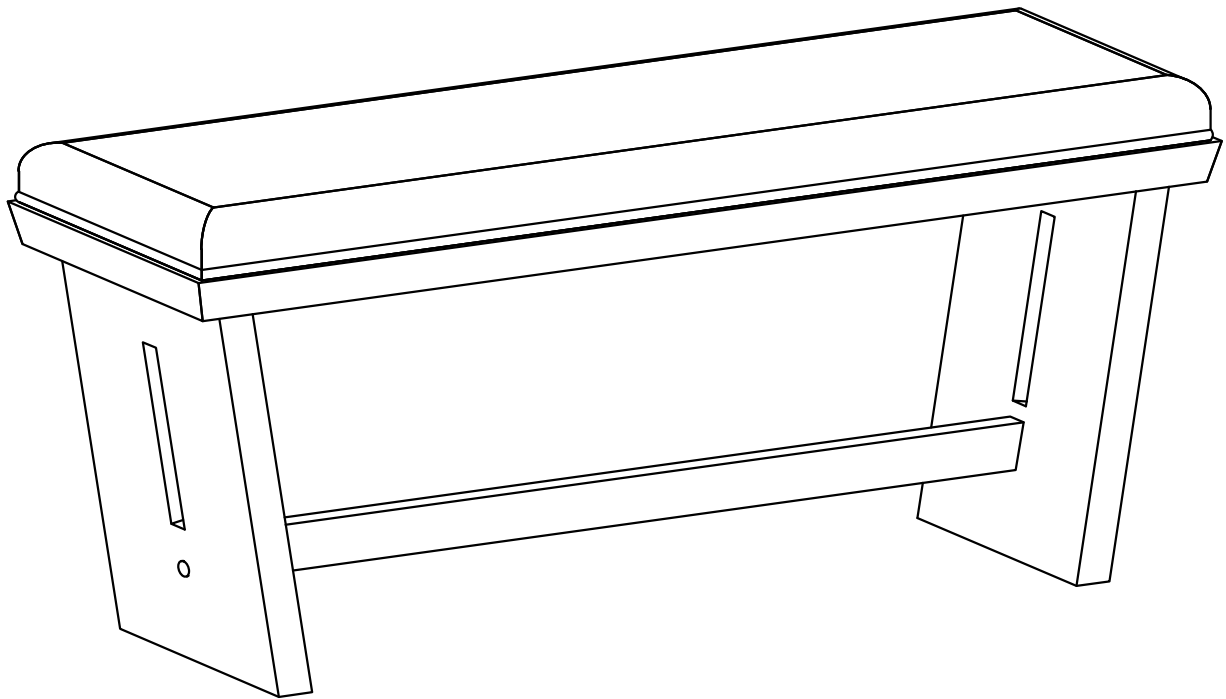

ASSEMBLY INSTRUCTIONS

ITEM NO.N715P194628

Please read these instructions fully before starting assembly:

1. Place all wooden parts on a clean and smooth surface such as a rug or carpet to avoid scratching the parts.
2. Kindly follow the assembly instructions step by step.
3. Do not tighten all screws and bolts until the stool is fully assembled.
4. Unscrew the protective plastique supports from the metal insert of the table legs before assembly.
5. Parts of the assembly will be easier with 2 people.

Care and maintenance:

Only clean using a damp cloth and mild detergent, do not use bleach or abrasive cleaners.

ASSEMBLY INSTRUCTION

ITEM NO.N715P194628

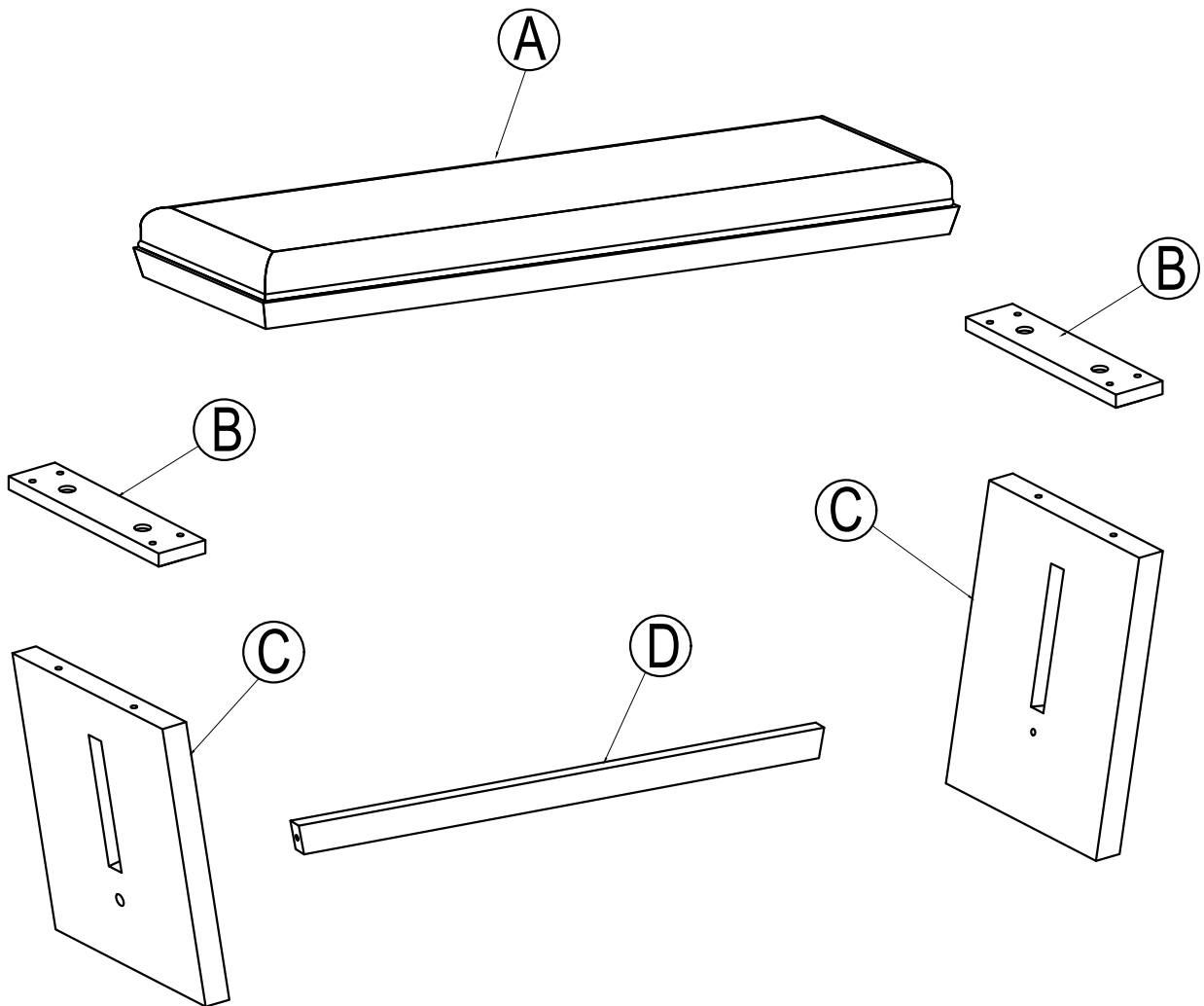

ASSEMBLY INSTRUCTION

ITEM NO.N715P194628

Part List

(A)

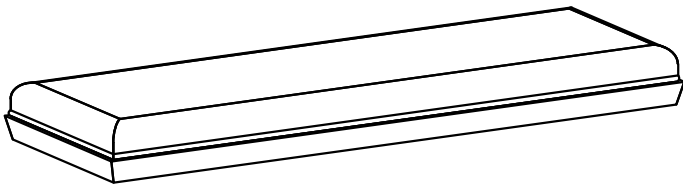

CUSHION SEAT (1 pc)

(B)

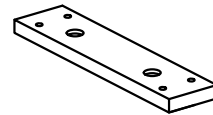

PANEL TOP LEG (2 pcs)

(C)

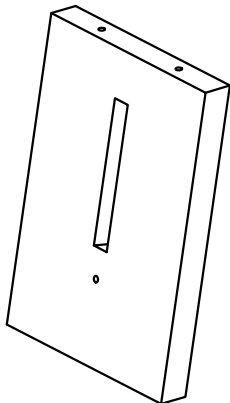

LEG (2 pcs)

(D)

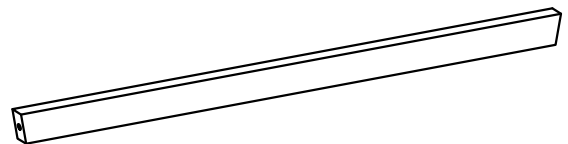

STRETCHER (1 pc)

ASSEMBLY INSTRUCTION

ITEM NO.N715P194628

Hardware List

①

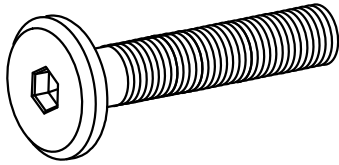

Ø 5/16" x 35 mm

BOLT (12 pcs)

②

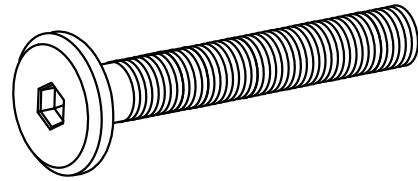

Ø 5/16" x 50 mm

BOLT (2 pcs)

③

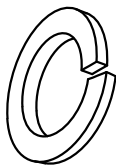

Ø5/16" x 13 mm

FLAT WASHER (14 pcs)

④

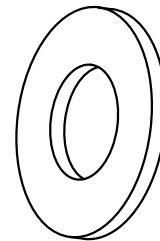

Ø5/16" x 16 mm

LOCK WASHER (12 pcs)

⑤



4 mm

ALLEN KEY (1 pc)

⑥

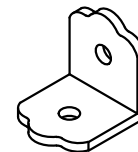

19 x 18 x 1.5 mm

PATCH V (2 pcs)

⑦



Ø 3.5 x 15mm

WOOD SCREWS (4 pcs)

⑧







WOOD PLUG (2 pcs)

ASSEMBLY INSTRUCTION

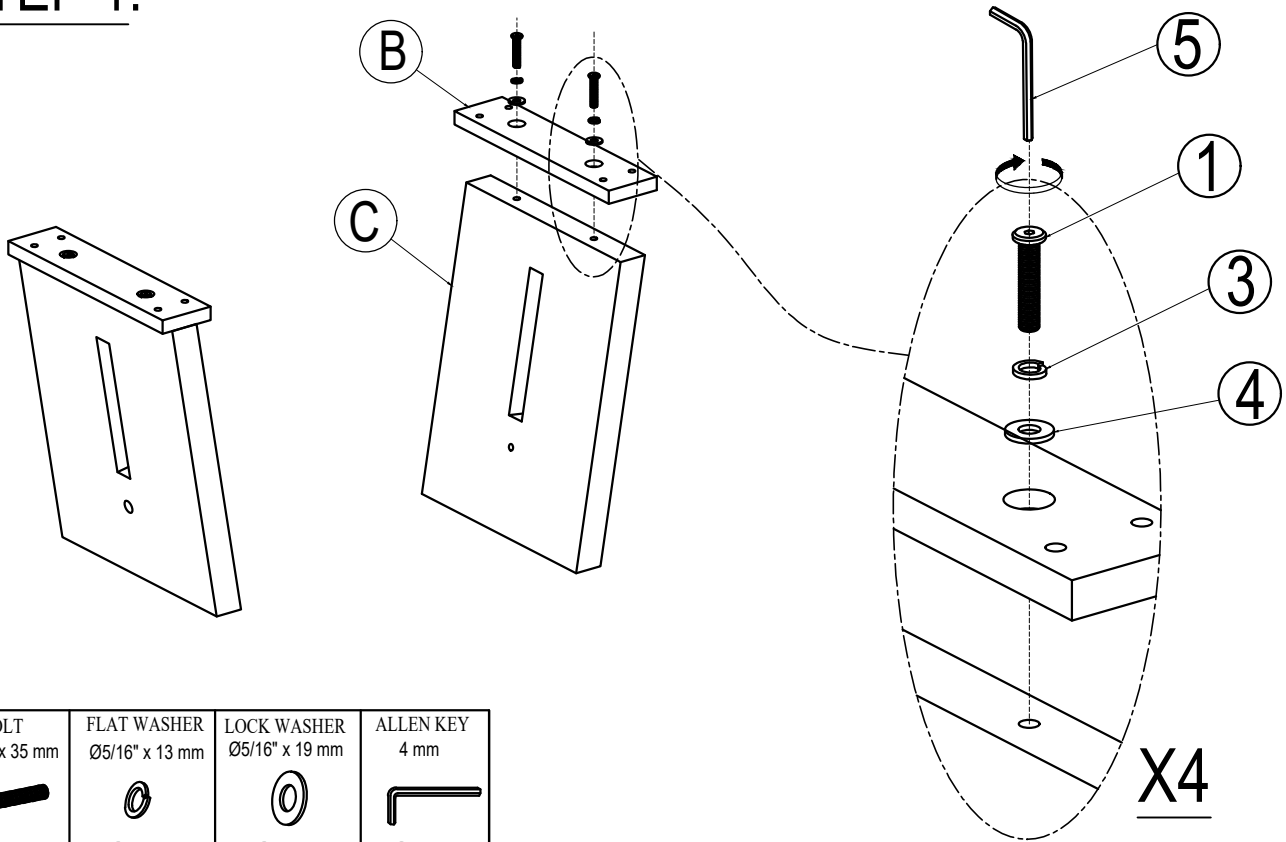
ITEM NO.N715P194628



STEP 1:

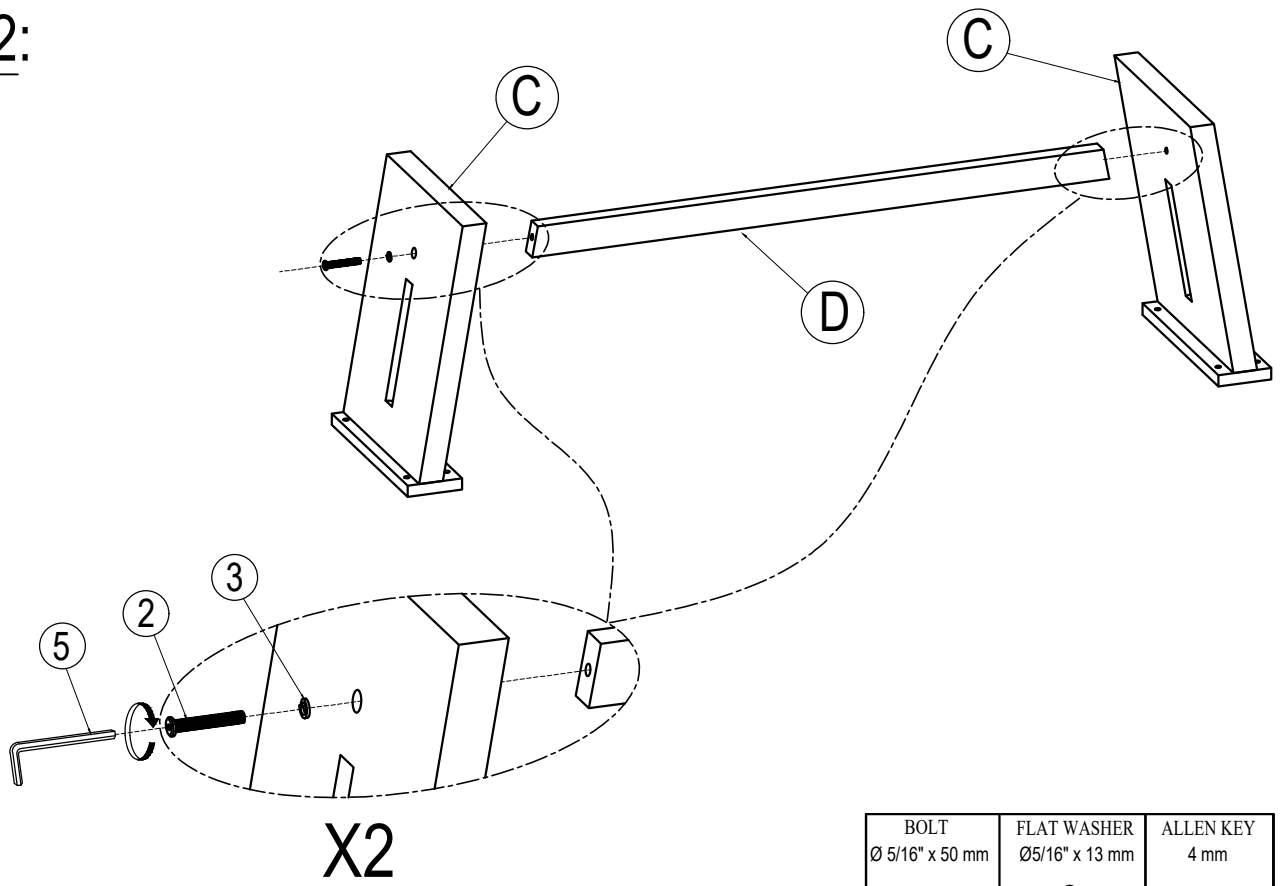

BOLT Ø 5/16" x 35 mm	FLAT WASHER Ø5/16" x 13 mm	LOCK WASHER Ø5/16" x 19 mm	ALLEN KEY 4 mm
			
①x 4	③x 4	④x 4	⑤x 1

STEP 2:







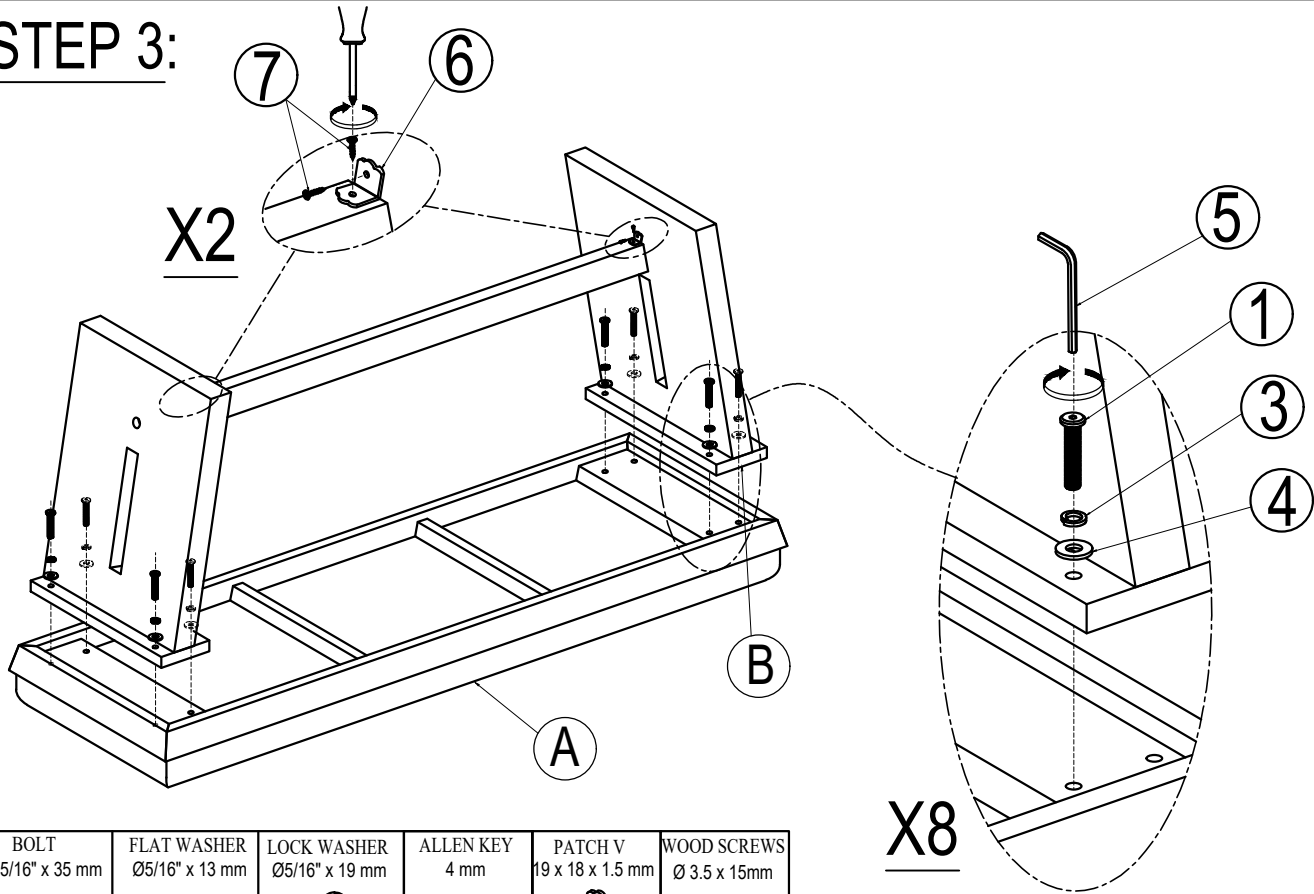

BOLT Ø 5/16" x 50 mm	FLAT WASHER Ø5/16" x 13 mm	ALLEN KEY 4 mm
		
②x 2	③x 2	⑤x 1

ASSEMBLY INSTRUCTION

ITEM NO.N715P194628

STEP 3:



BOLT Ø 5/16" x 35 mm	FLAT WASHER Ø5/16" x 13 mm	LOCK WASHER Ø5/16" x 19 mm	ALLEN KEY 4 mm	PATCH V 19 x 18 x 1.5 mm	WOOD SCREWS Ø 3.5 x 15mm
					
① x 8	③ x 8	④ x 8	⑤ x 1	⑥ x 2	⑦ x 4

COMPLETE

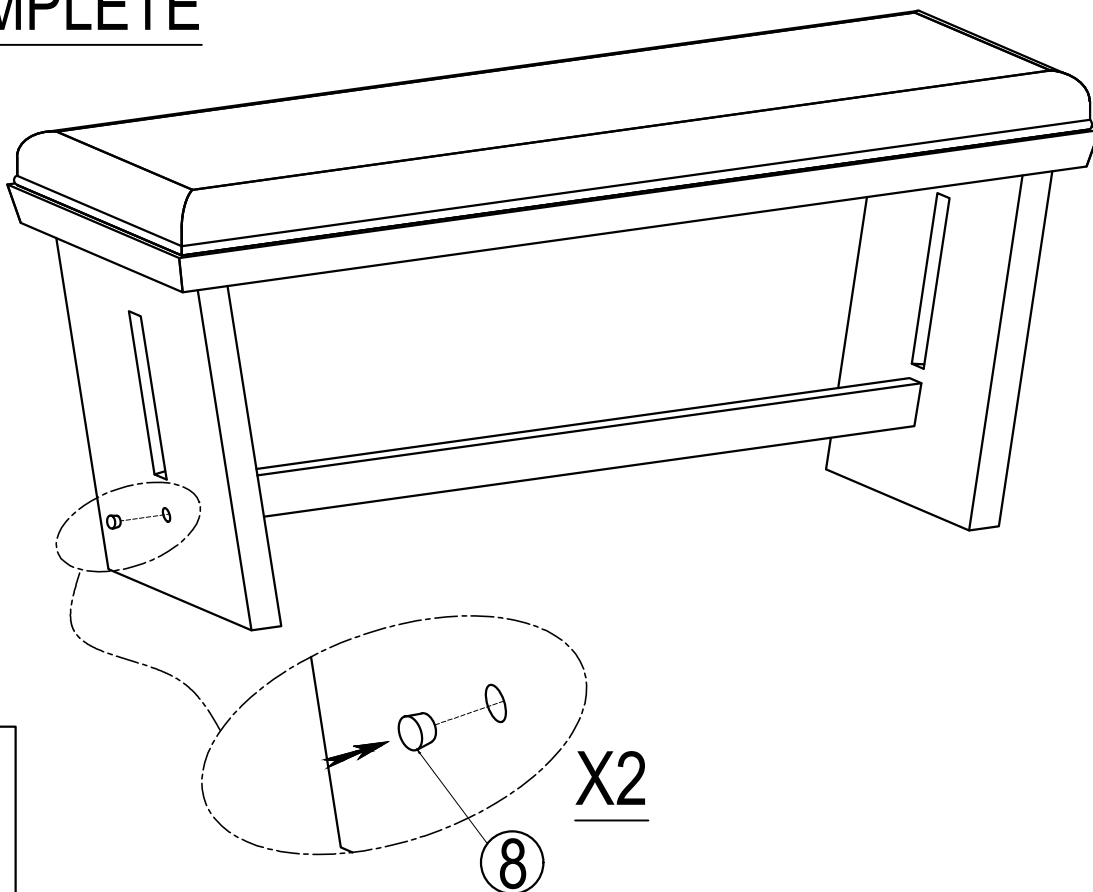

WOOD PLUG

⑧ x 2