

ASSEMBLY INSTRUCTIONS

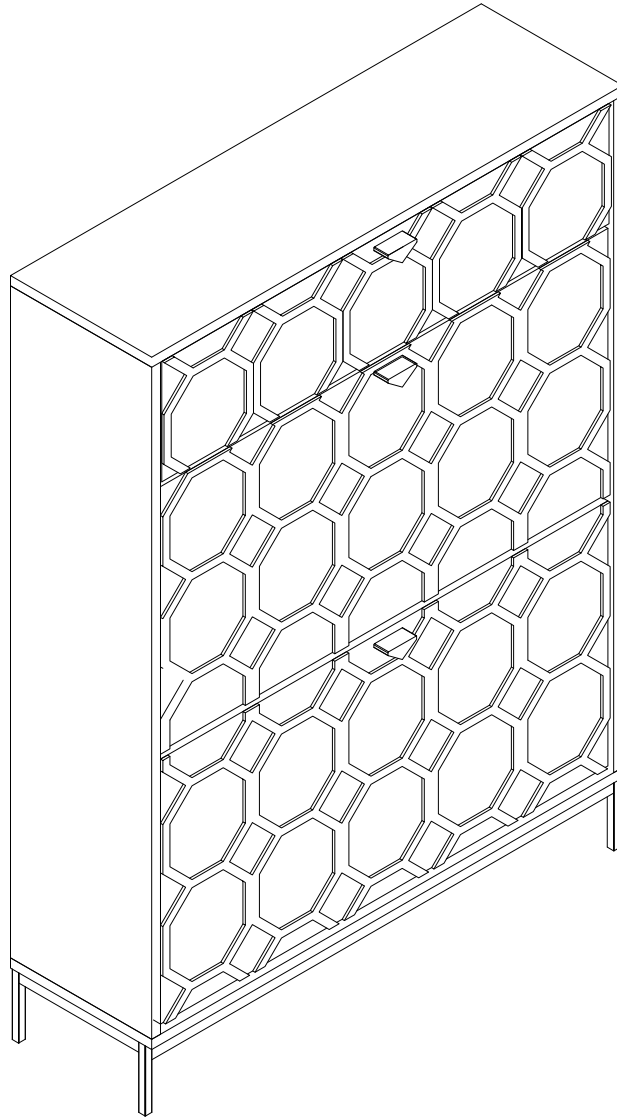

It is normal for the sealed environment to smell, not a product quality problem.

Phone number: 303-747-4421
(951) 213-4743

service@clihome.net
Web:www.clihome.net

PACKAGE CONTENTS

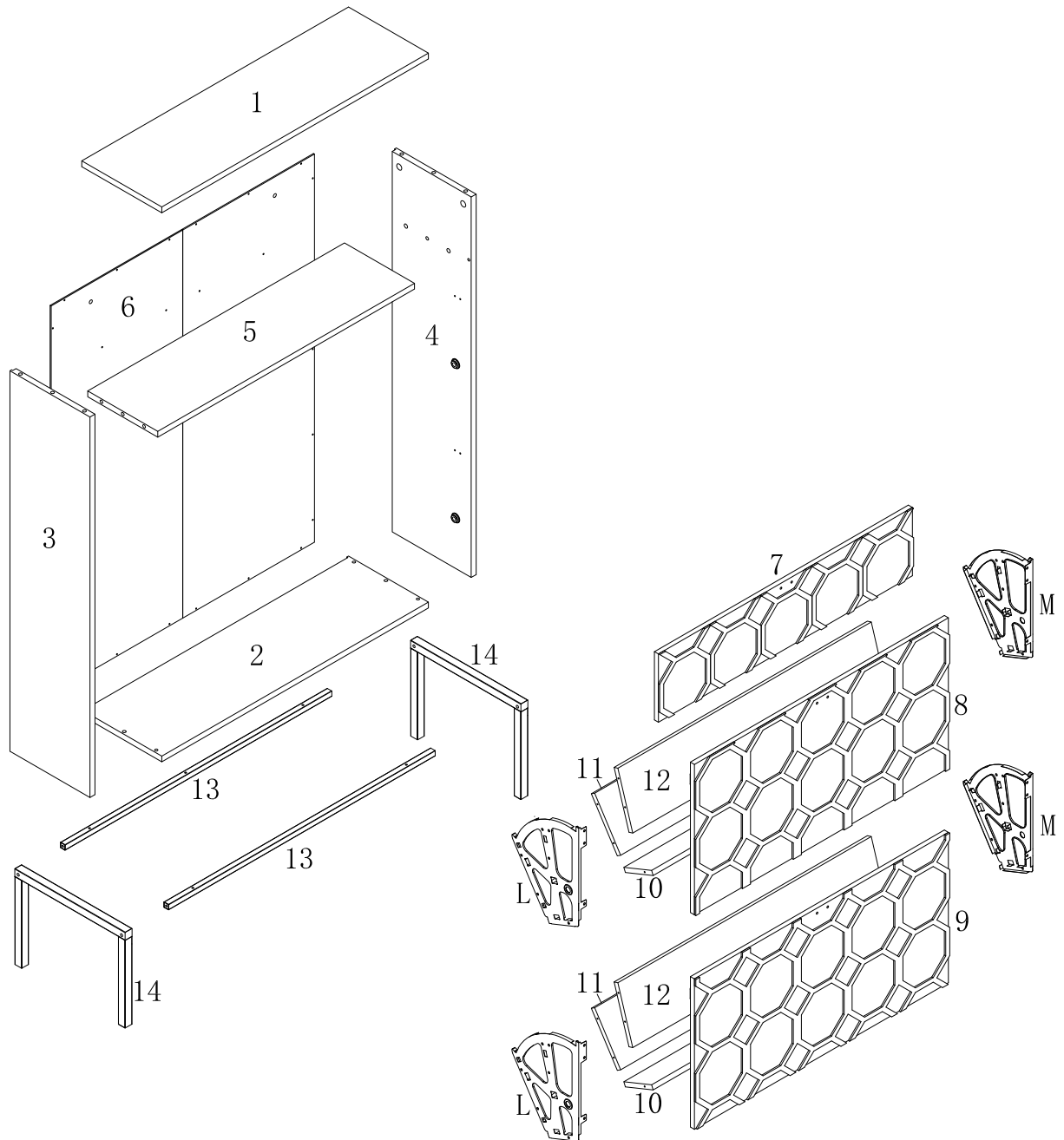

Assembly Details

40 mins

Approximate Assembly Time

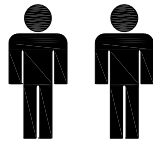

2 person assembly

Floor Area:

1.5X1.5 meters

Required Assembly Space

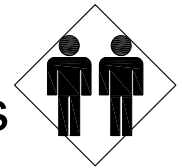

Required Assembly Tools

Phillips-Head Screwdriver

Allen Wrench



Tips Before you Start

1. Please check that all parts are present before you start the assembly of your furniture.
2. For ease and speed of assembly, we recommend that before you commence each step of the assembly, that you identify all the parts required for that step.
3. We recommend that, where possible, all items are assembled near to the area in which they will be placed in use, to avoid moving the product unnecessarily once assembled.
4. For the protection of your furniture, we recommend that the product is placed on a protected surface during assembly to prevent any damage.
5. During assembly please take care not to over-tighten any fittings, as this may damage the product.
6. Always place the product on a flat, steady and stable surface.
7. Do not stand on the product. Do not use the product as a stepladder.
8. Please use caution and care when lifting the product to avoid personal injury and/or product damage.

Care and Maintenance

- Upon completion of assembly be sure that all screws, bolts and fastening.
- Never clean with abrasive ammonia base, bleach base or spirit type cleaners.

ASSEMBLY INSTRUCTIONS

Part List:

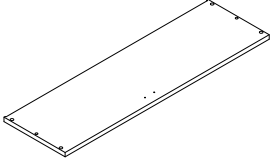
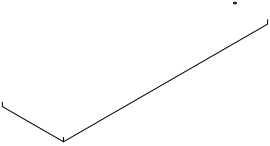
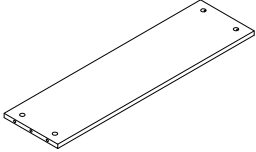
ITEM	DESCRIPTION	PART	QTY
1	Top panel		1
2	Bottom panel		1
3	Left side panel		1
4	Right side panel		1
5	Shelf		1
6	Back panel		1

Part List:

ITEM	DESCRIPTION	PART	QTY
7	Upper door panel		1
8			1
9			
10	Bottom lamination		2
11			2
12			2

ASSEMBLY INSTRUCTIONS

Part List:

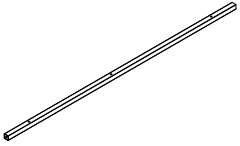



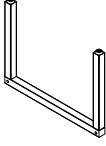





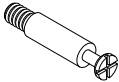

ITEM	DESCRIPTION	PART	QTY
13	Metal Strip		2

Part List:



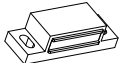

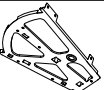







ITEM	DESCRIPTION	PART	QTY
14	Metal Leg		2

ASSEMBLY INSTRUCTION

Hardware List:

ITEM	DESCRIPTION	PART	QTY
A	Camlock bolt		8
B	Camlock		8
C	Wooden dowel	 Φ8*30mm	6
D	Bolt	 Φ1/4"*1 1/8"	8
E	Bolt	 Φ1/4"*1 1/2"	4
F	Allen wrench		1
G	Handle		3
H	Machine screw	 Φ5/32"*3/4"	6
I	Magnet		3
J	Wood screw	 Φ3*15mm	26
K	Wood screw	 Φ3*12mm	18
L	Left bracket		2
M	Right bracket		2

Hardware List:

ITEM	DESCRIPTION	PART	QTY
N	Screw button		4
O	Screw	 Φ4*10mm	4
P	Stopper		4
Q	Safety hinge		1
R	Left hinge		1
S	Right hinge		1
T	Back screw	 Φ3*12mm	26
U	Safety wall strap		2
V	Plastic anchor		4
W	Mounting screw	 Φ4*38mm	4
X	Washer		2
Y	Wood screw	 Φ3*12mm	4
Z	Wood screw	 Φ3*19mm	8

- * Required screwdriver & mallet, not included.
- * Before discarding packing materials, please check to make sure that all parts and hardware is present.
- * Two people needed for assembly.
- * Please follow the instructions closely; do not over tighten screws or bolts unless instructed.
- * After a few days from initial assembly, the product may have acclimated to the new environment. Please retighten the hardware.

Guideline For Assembling of Cam Lock(A & B)

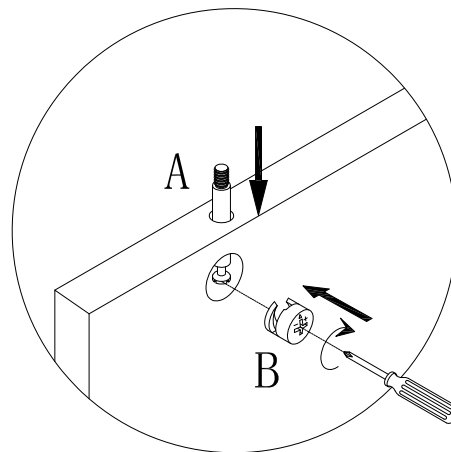
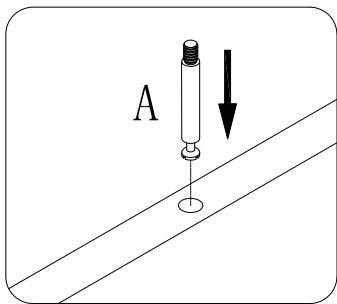



Screw camlock bolt (A) to wood part.

Do not assemble camlock (B) unless instructed.

To assemble camlock (B), ensure long side of the + is facing the bolt (A) before inserting into hole.

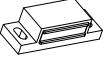

ASSEMBLY INSTRUCTION

STEP 1

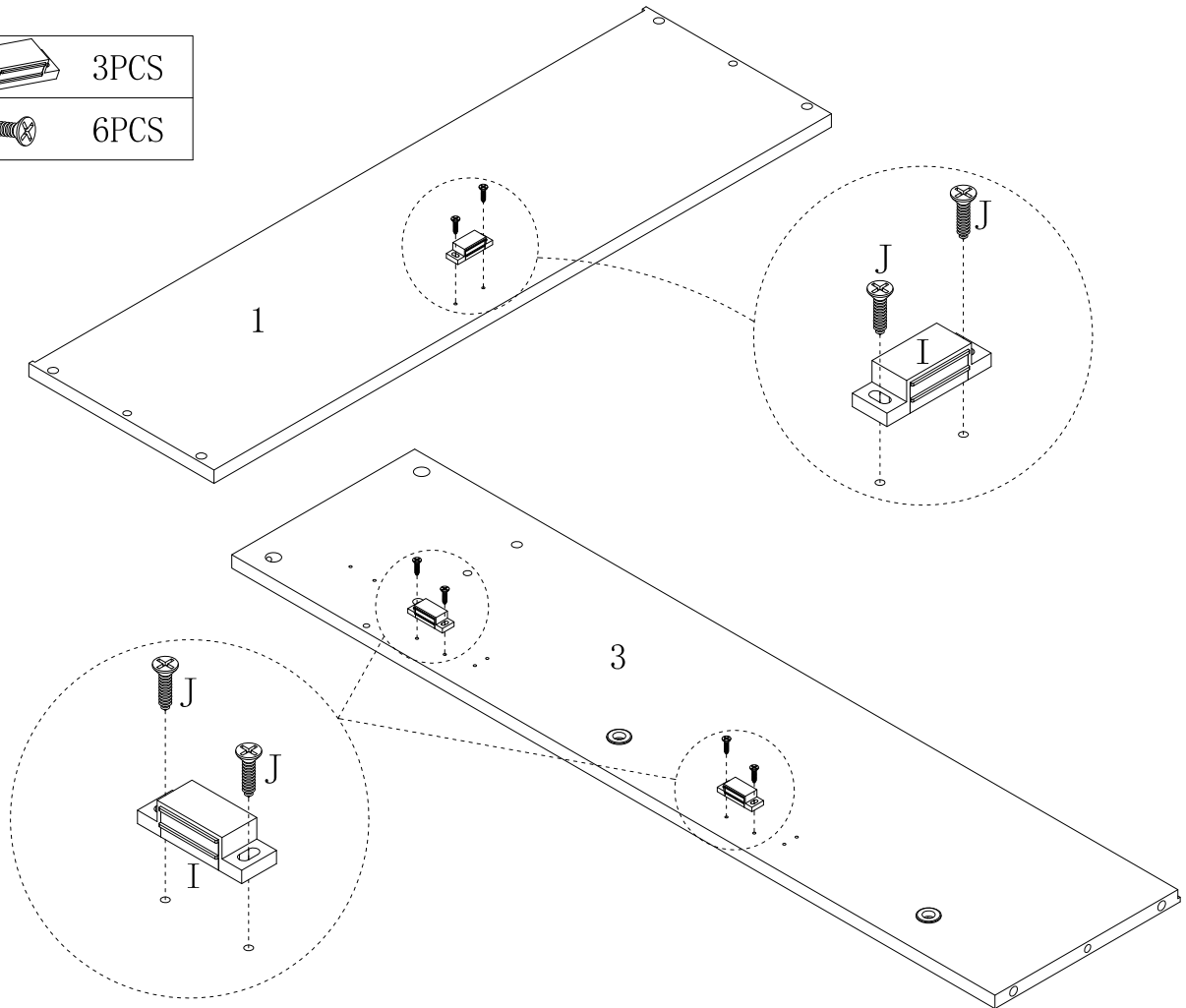
- | | | |
|----|---|------|
| I: |  | 3PCS |
| J: |  | 6PCS |







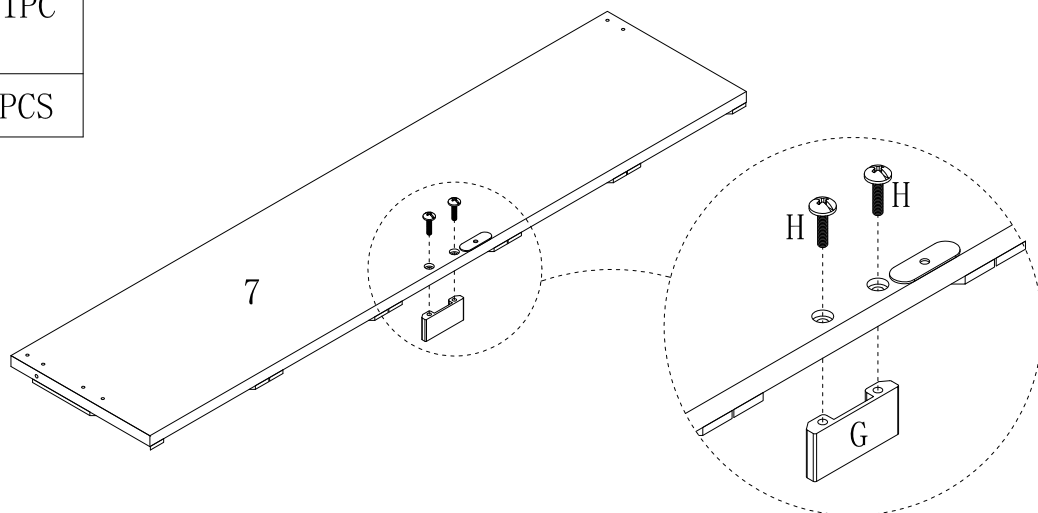

STEP 2

- | | | |
|----|---|------|
| G: |  | 1PC |
| H: |  | 2PCS |



ASSEMBLY INSTRUCTION





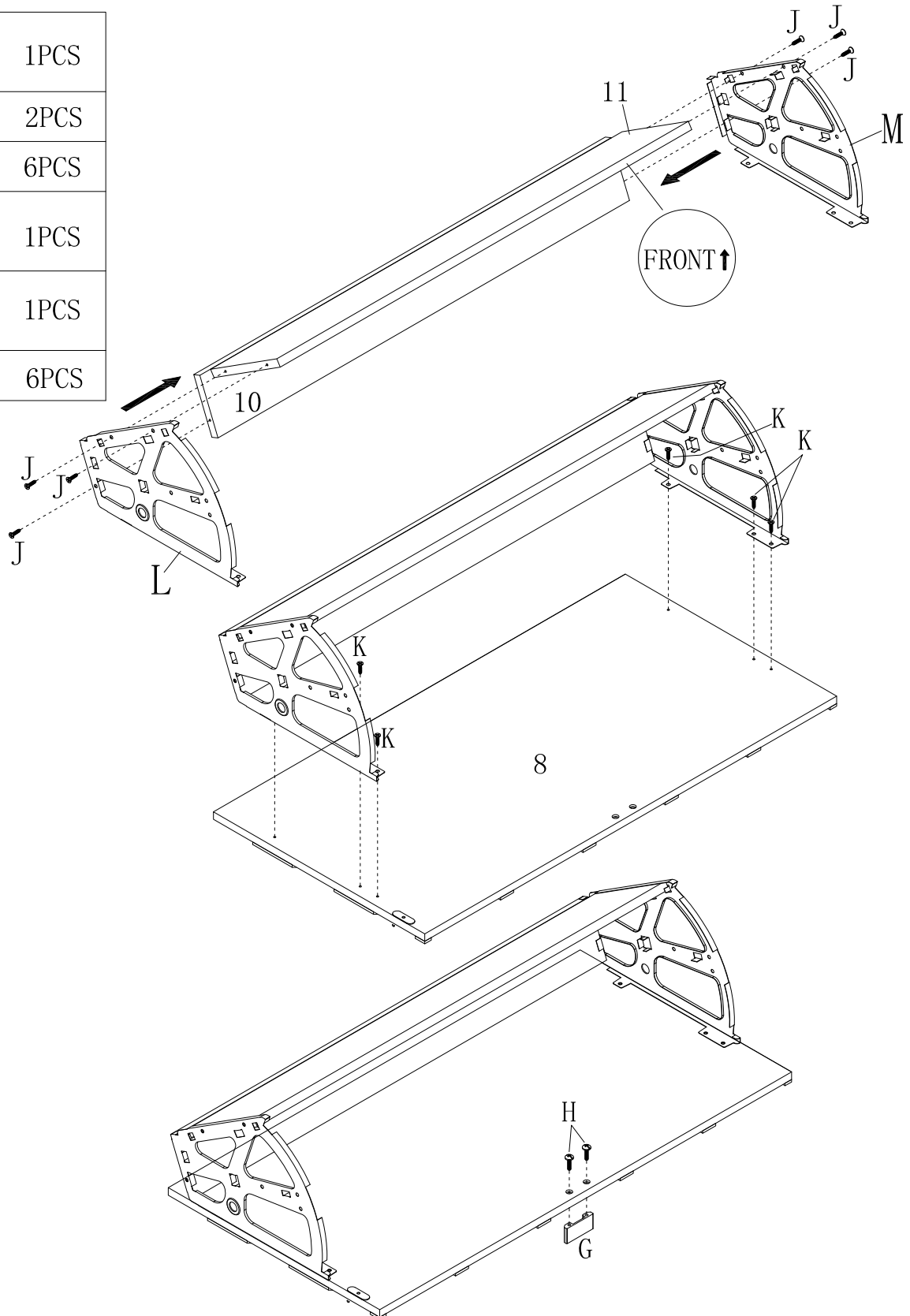

STEP 3

G:		1PCS
H:		2PCS
J:		6PCS
L:		1PCS
M:		1PCS
K:		6PCS



ASSEMBLY INSTRUCTION

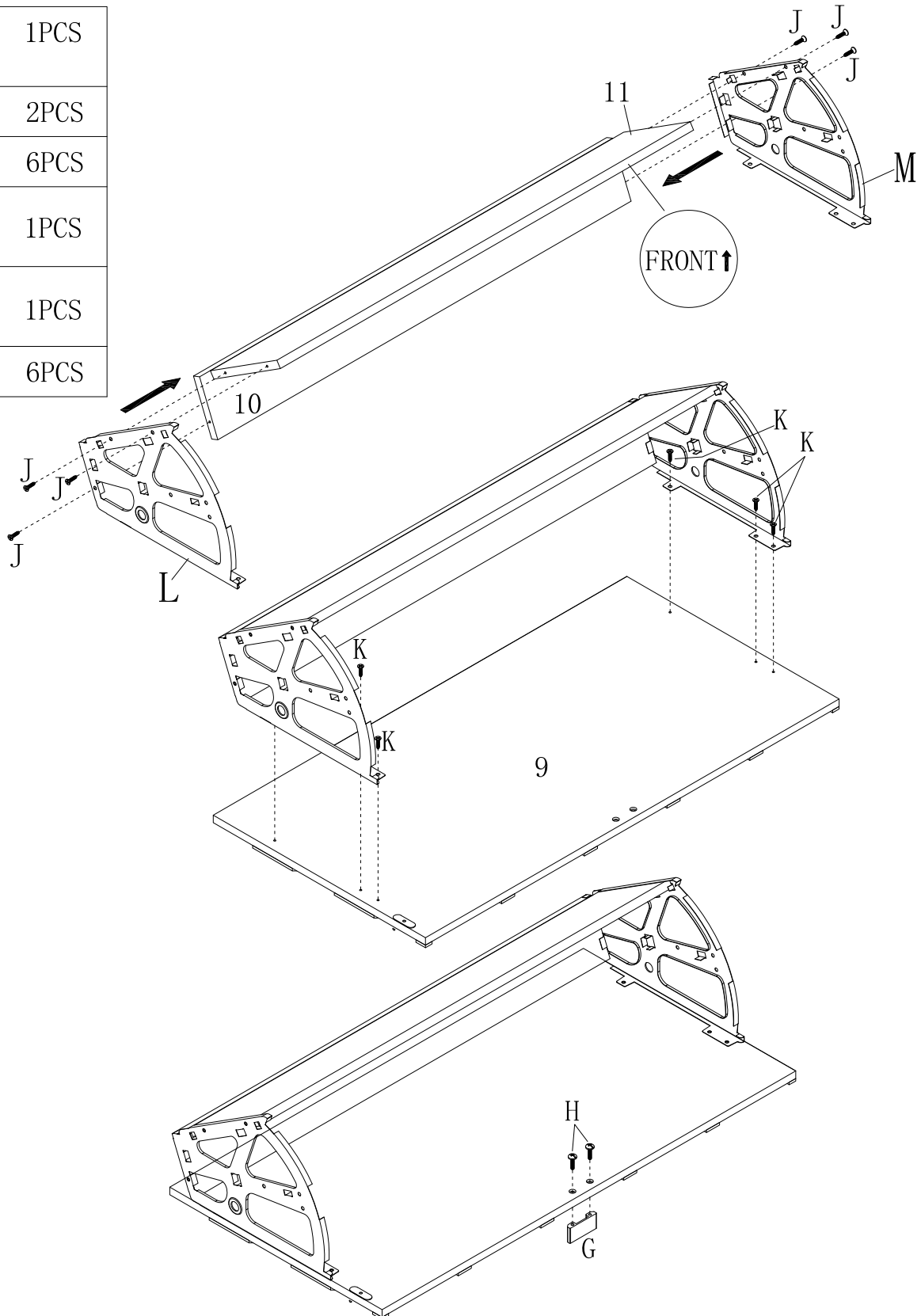

STEP 4

G:		1PCS
H:		2PCS
J:		6PCS
L:		1PCS
M:		1PCS
K:		6PCS





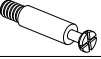

ASSEMBLY INSTRUCTION

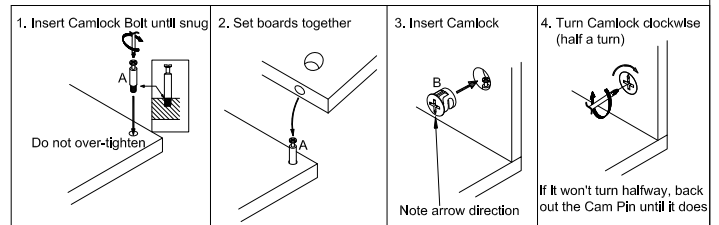
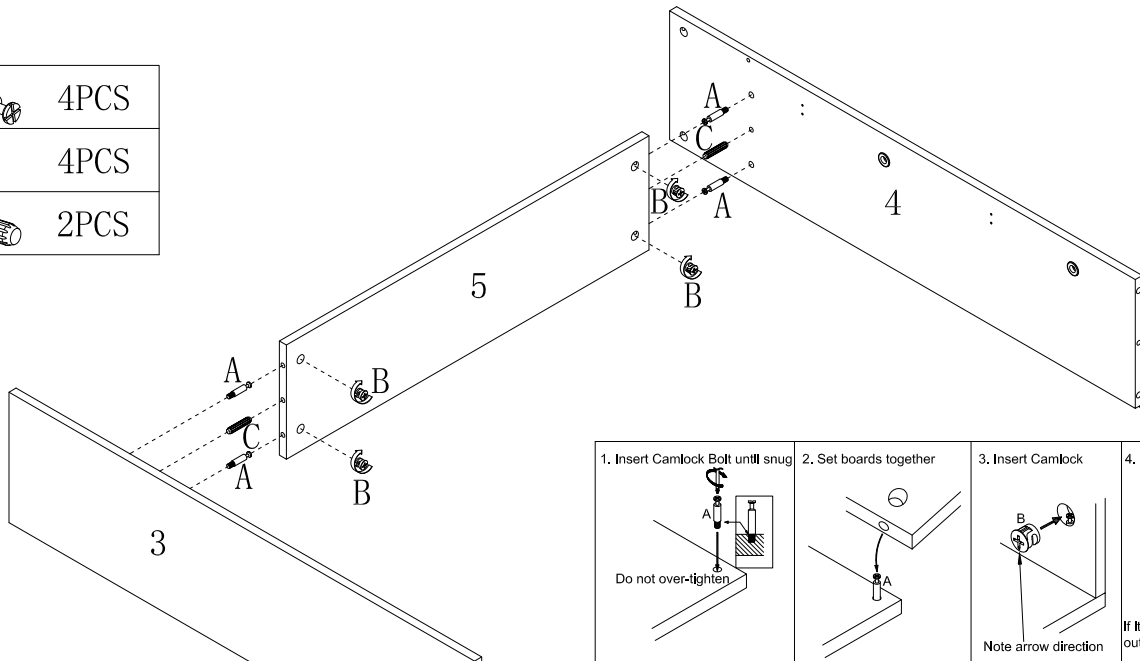
STEP 5

A:		4PCS
B:		4PCS
C:		2PCS

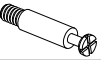

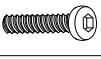
STEP 6

A:		4PCS
B:		4PCS
C:		4PCS
D:		4PCS
F:		1PC

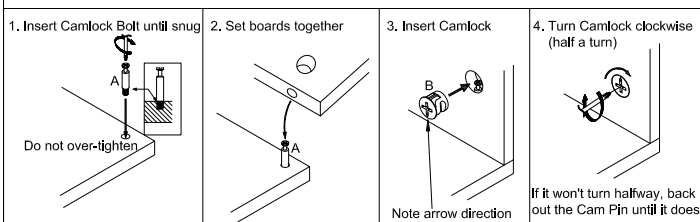
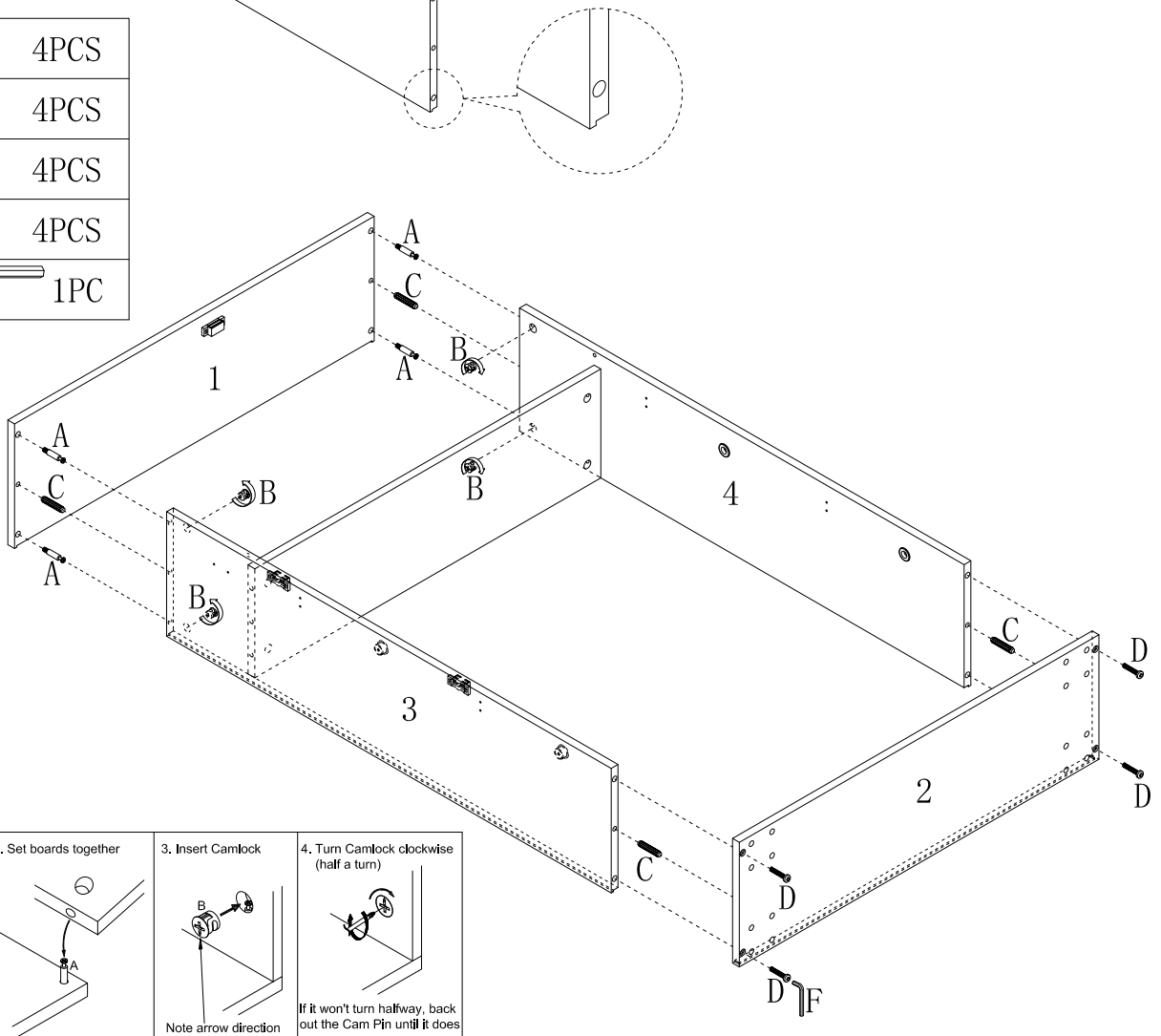

ASSEMBLY INSTRUCTION

STEP 7

E:  4PCS

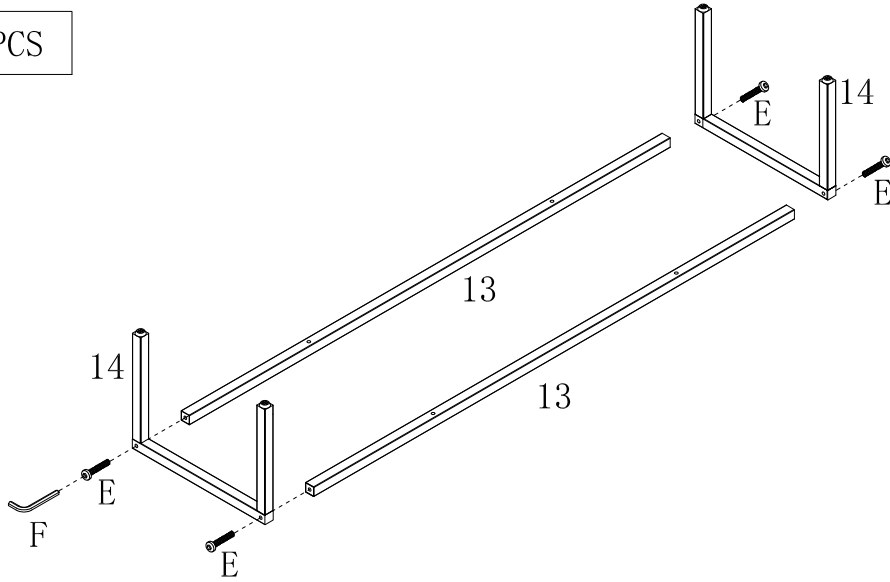

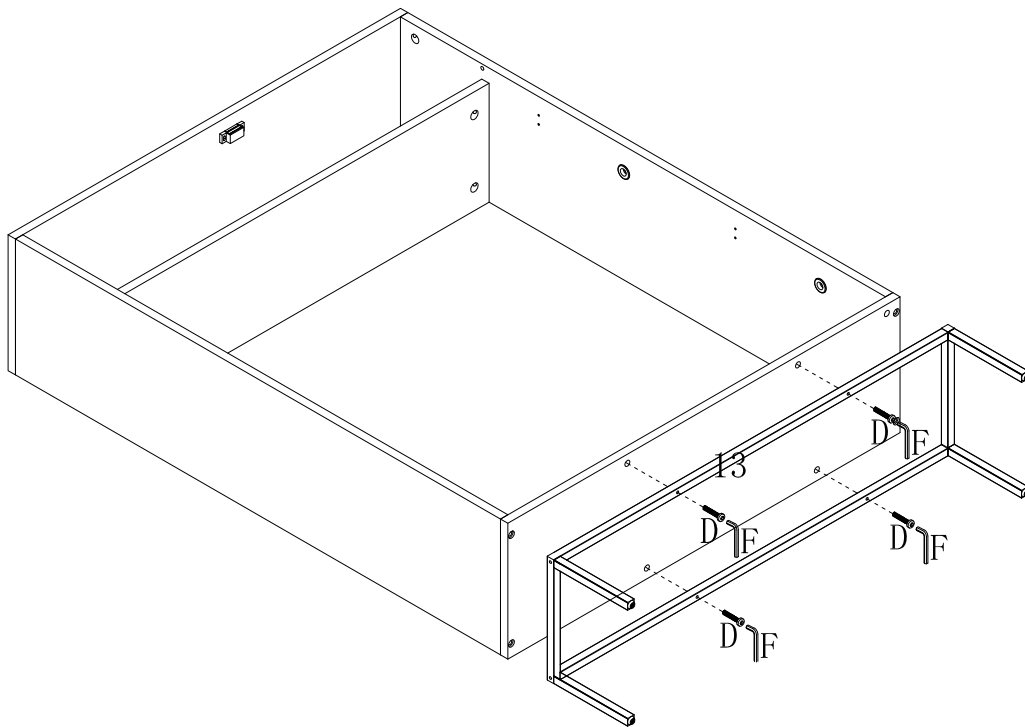

STEP 8

D:  4PCS



STEP 9



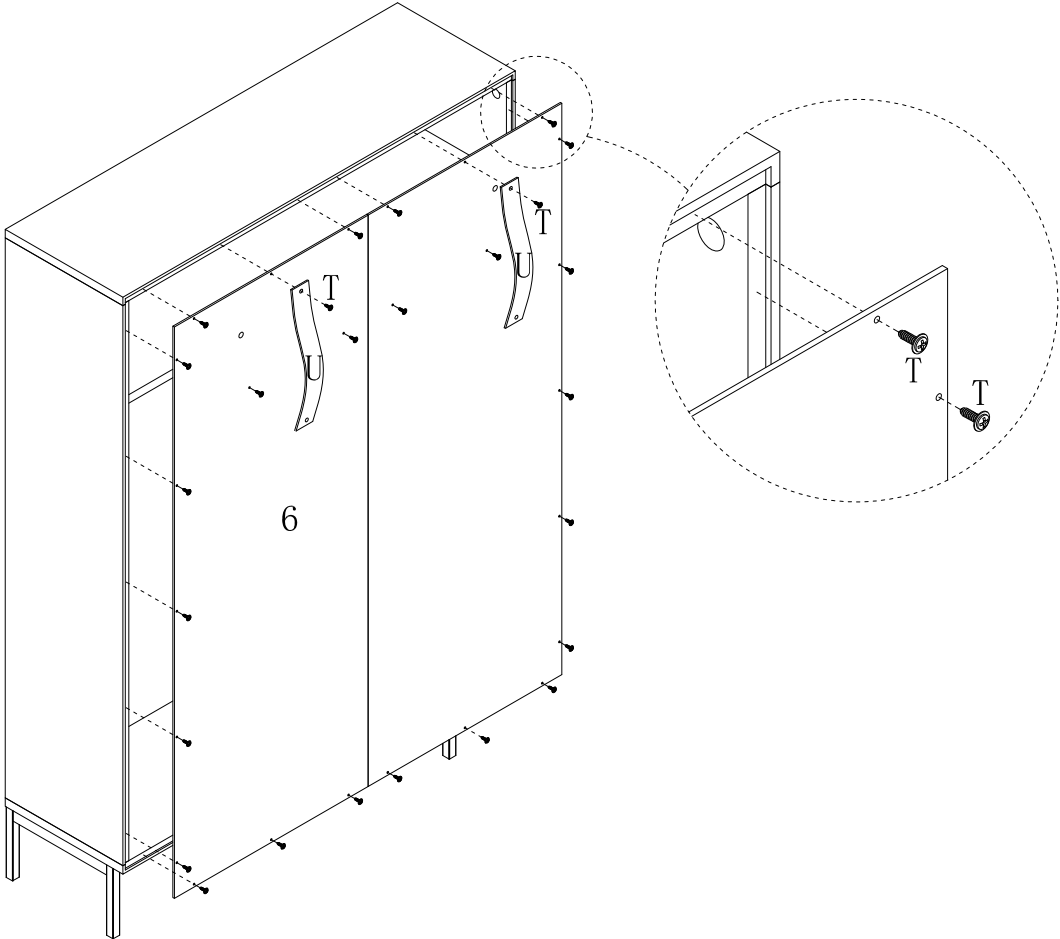

T:		26PCS
U:		2PCS



ASSEMBLY INSTRUCTION

STEP 10

Repeat step 10 for the other shoe storage.

J:		16PCS
N:		4PCS
O:		4PCS
P:		4PCS

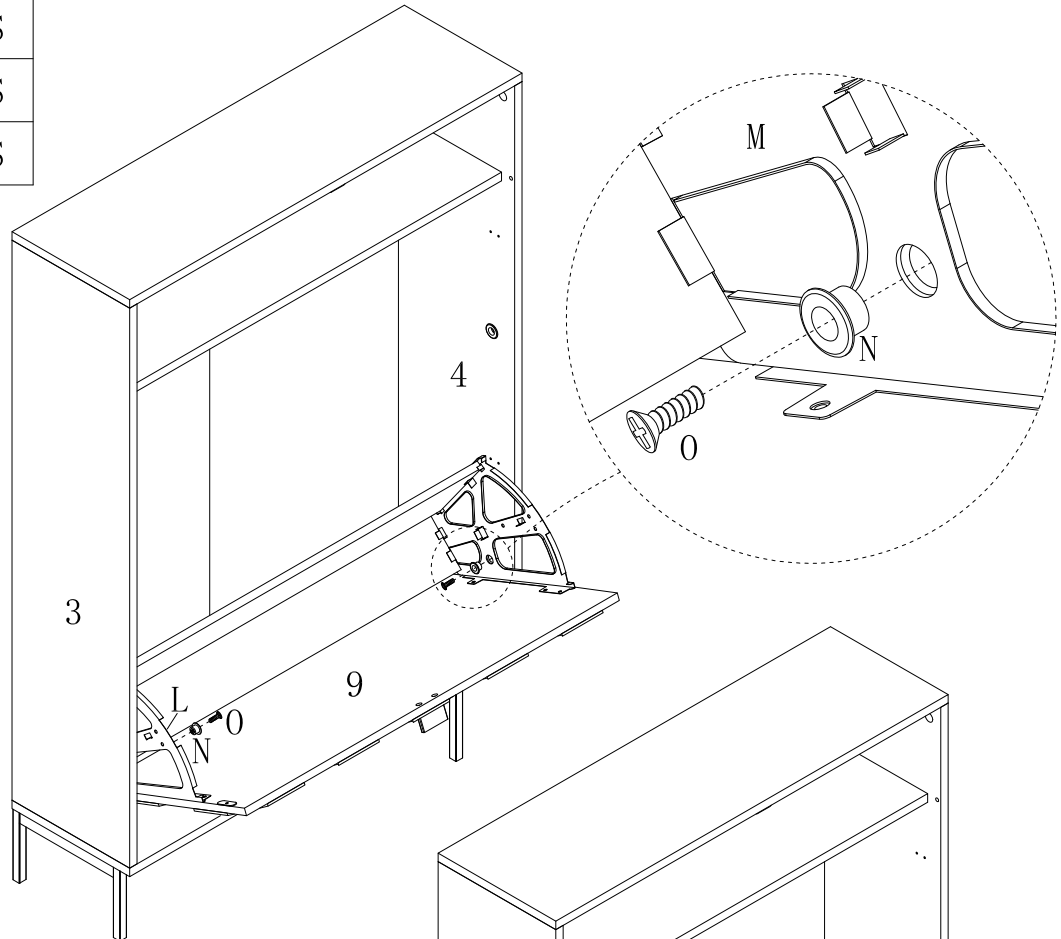

Slide middle lamination (part #12) into slot of the bracket (part #L and #M).

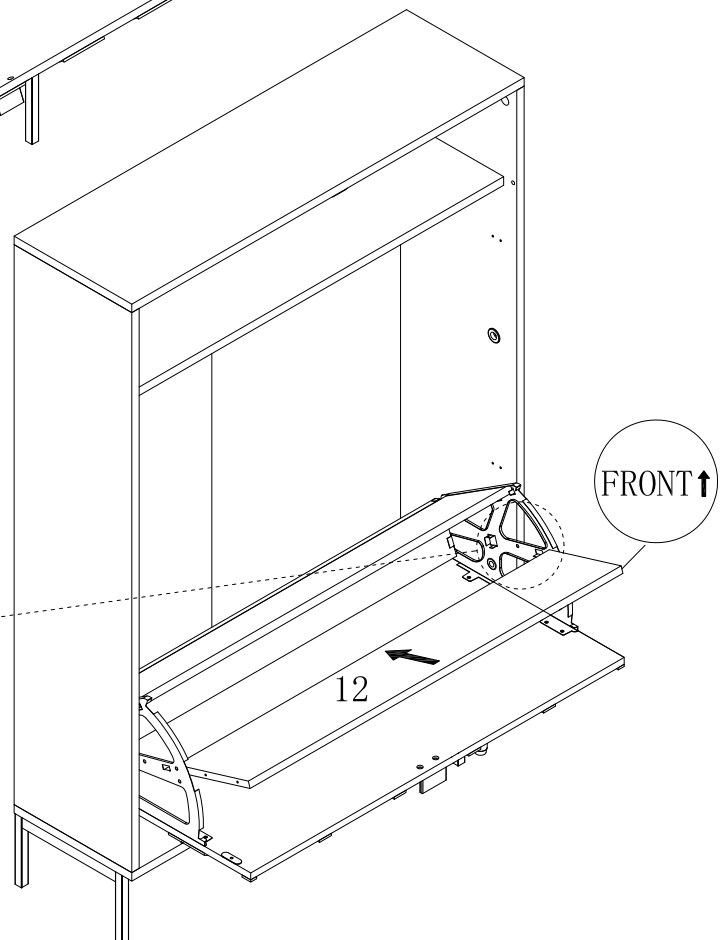
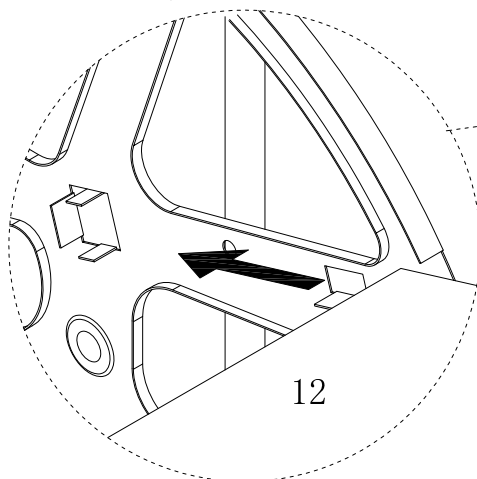

ASSEMBLY INSTRUCTION

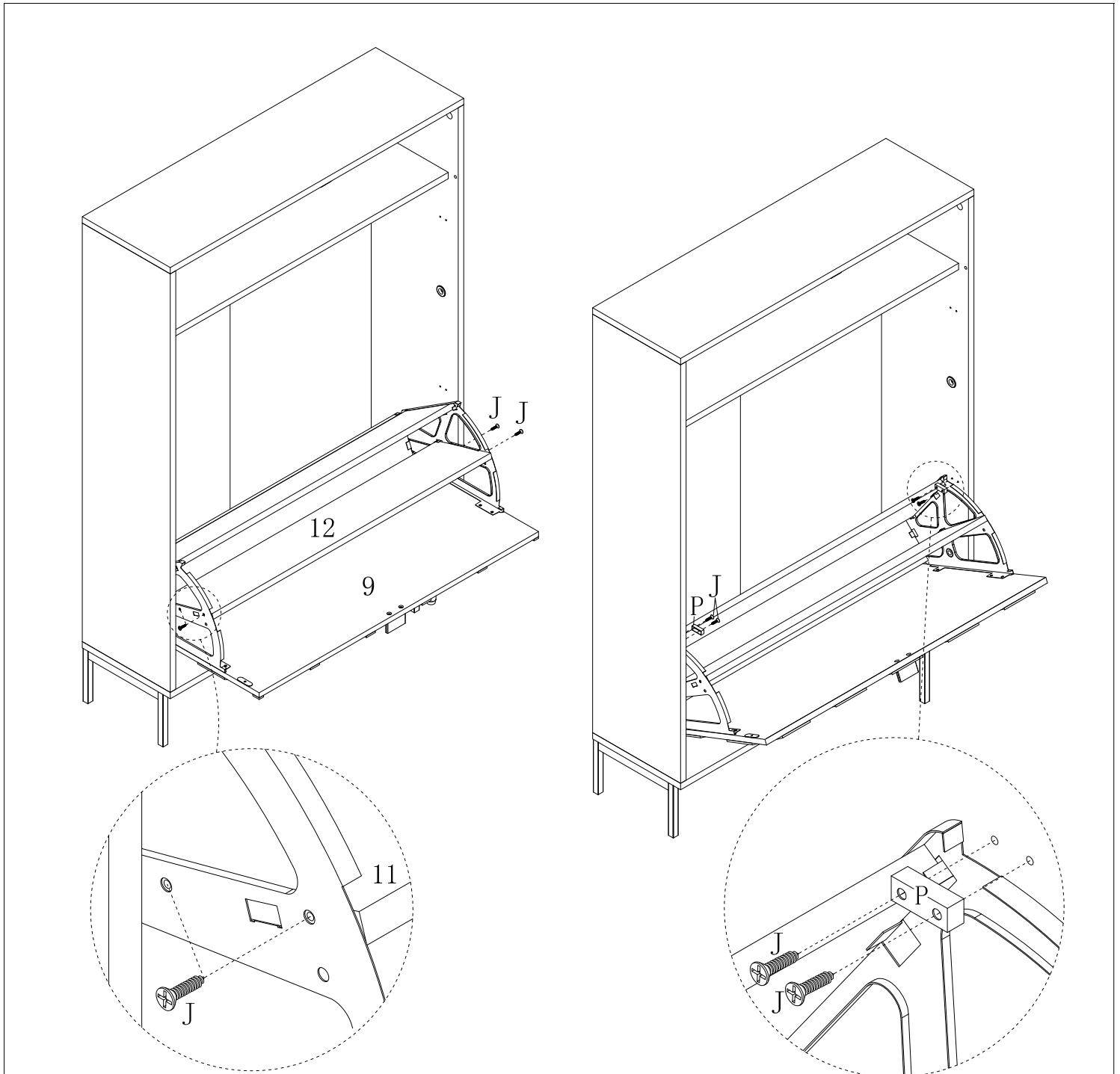

To stop shoe storage drop fully.

Push the shoe storage back panel back to the desired position, then attach stopper (part P) into desired position on side panels (part #3 and #4) using screw (Part #J) .

ASSEMBLY INSTRUCTION

STEP 11

K:  6PCSR:  1PCS:  1PC

Place hinge (part R) into desired position on left side panel (part #3) and place hinge (part S) into desired position on right side panel (part #4), then slide shelf (part #7) into place and tighten the screw (part #K).

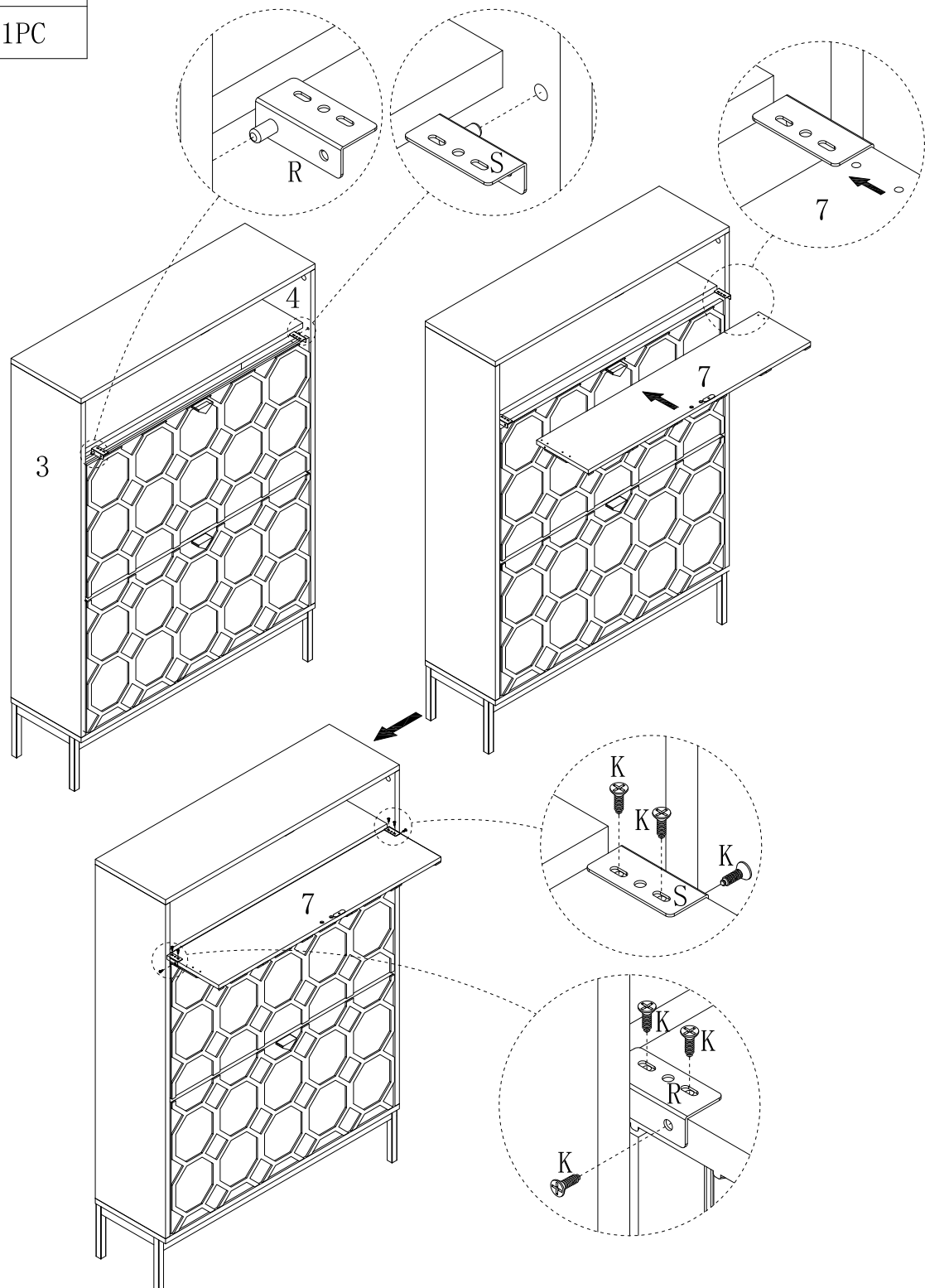

ASSEMBLY INSTRUCTION

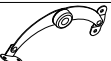

STEP 12

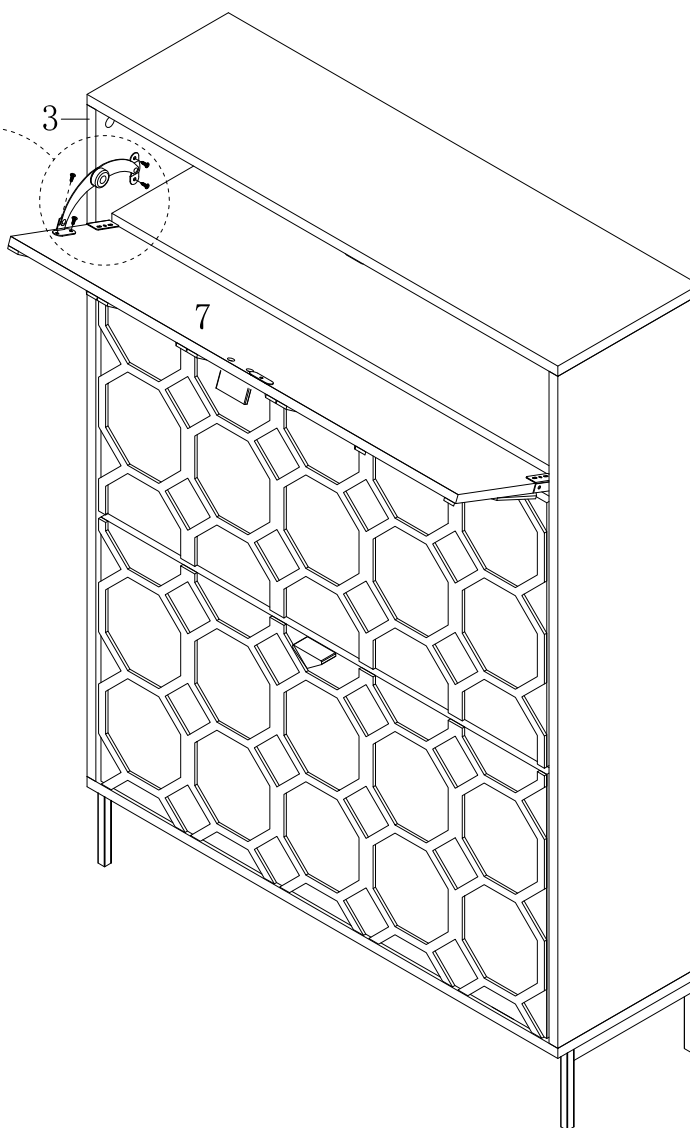
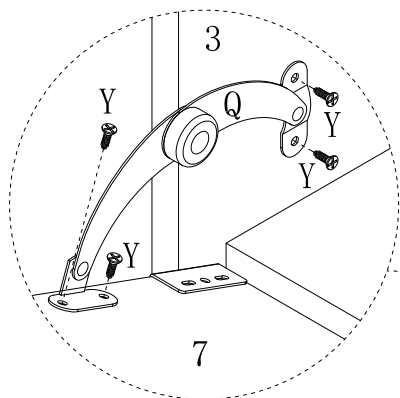
Y:		4PCS
Q:		1PC



ASSEMBLY INSTRUCTION

STEP 13

V:		4PCS
W:		4PCS
X:		2PCS

Wall

For safety reasons, it is recommended to install safety wall strap to fix the item.

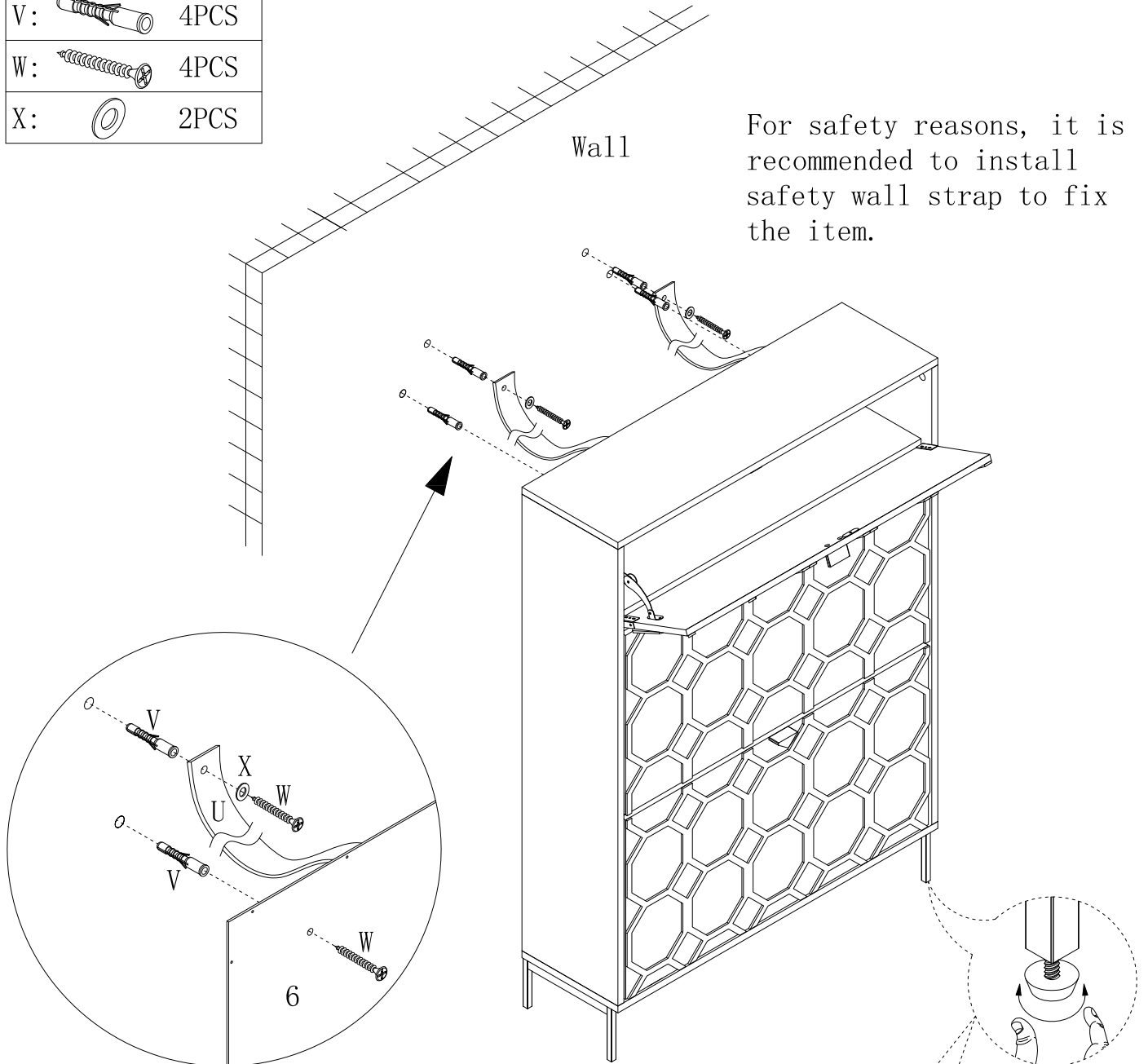

After installation, adjust the adjustable foot to keep the cabinet balanced and align the door.