

# ASSEMBLY INSTRUCTIONS



## CAUTION

◆ Inspect the wire insulation for any cuts, abrasions, or exposed copper that may have resulted during shipping. If there is a defect in the wire, do not attempt installation.

◆ Before starting installation of this fixture or removal of a previous fixture, disconnect the power by turning off the circuit breaker or by removing the fuse at the fuse box.

✉ If you need further assistance, please contact us by Email: [customersupport@superiordecorinc.com](mailto:customersupport@superiordecorinc.com)

## TOOLS REQUIRED



Ladder



Safety glasses



Electrical tape



Phillips screwdriver



Flat blade screwdriver



Pliers

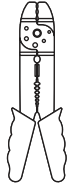

Wire strippers

\* PARTS SHOWN MAY DIFFER SLIGHTLY PER LIGHT FIXTURE

## HARDWARE INCLUDED



Cover

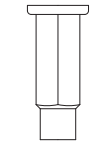

Centre Pillar

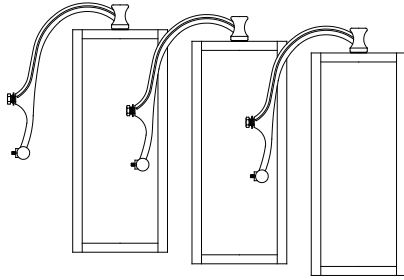

Decorative Component  
(Hex Nut A, Washer)



Screws (short)



Rubber Rings

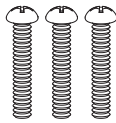

Screws (Thick)

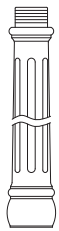

Decorative Pillar  
(TOP)

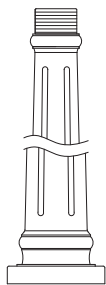

Decorative Pillar  
(MIDDLE)

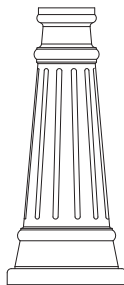

Decorative Pillar  
(BOTTOM)

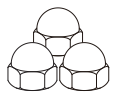

Big Cap Nuts



Electric Wire



Wire Nuts

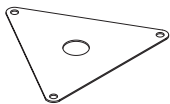

A Tripod

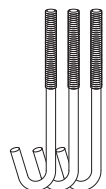

Iron Hook



Hex Nuts B

## EXPLODED PARTS

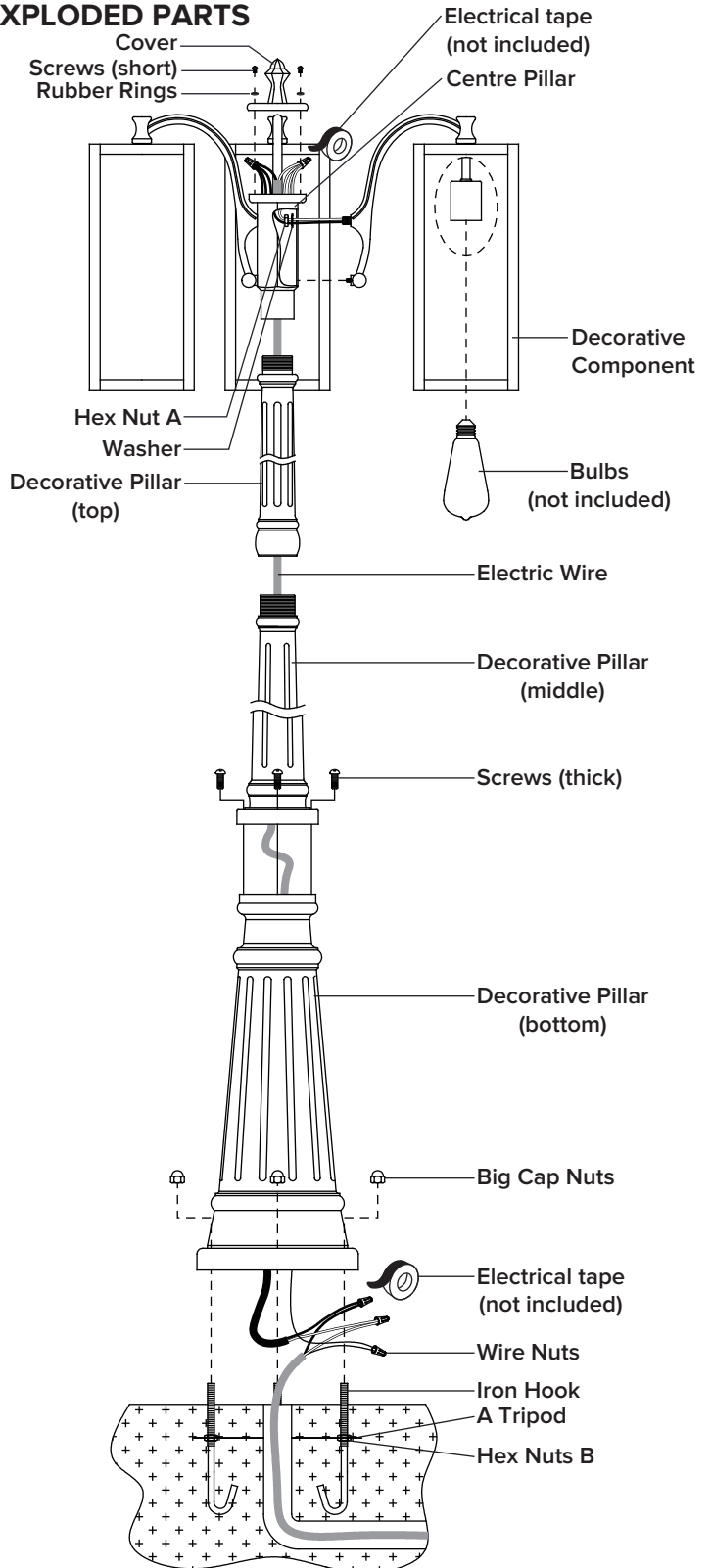

# INSTALLATION

## STEP 1

Install **iron hook** into the **a tripod** with the **hex nuts C** then embed the component in the ground level with concrete.

Note: the threaded nipple must protrude outward 1 5/8"(41mm).

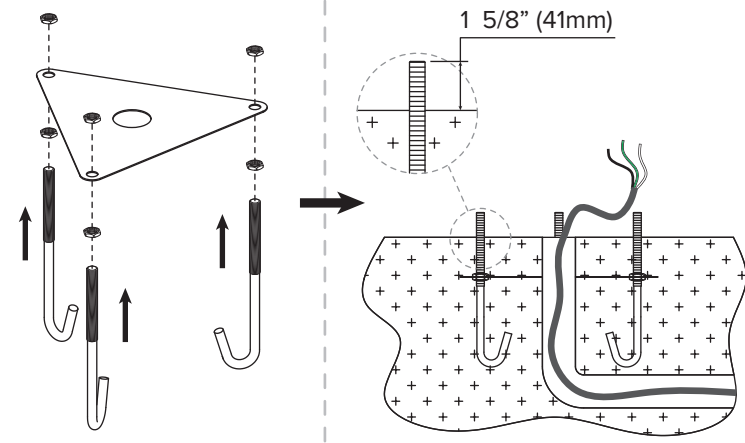

## STEP 2

Successively install the **decorative component** into **centre pillar** and secure them with **washer and hex nuts A**.

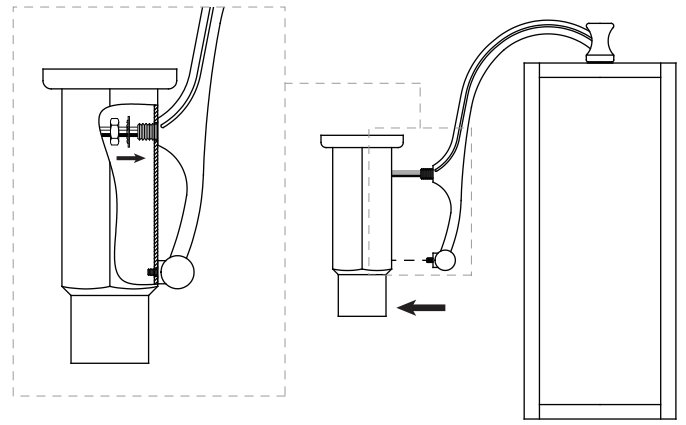

## STEP 3

Run the **electric wire** across the **centre pillar**.

Next, connect the black wire and white wire with the supplied **wire nuts**. Secure with electrical tape(not included). Then carefully tuck wires back into the **centre pillar**.

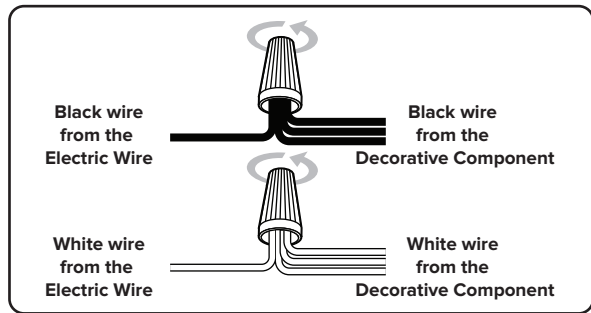
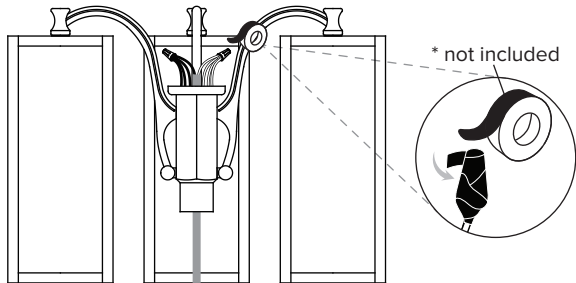

## STEP 4

Install the **cover** into **centre pillar** and secure with **rubber rings and screws (short)**.

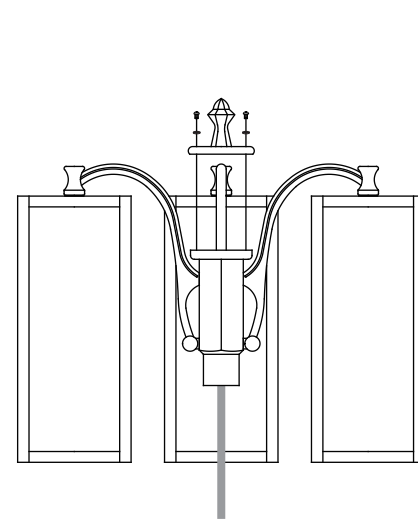

## STEP 5

Install bulb (not included).

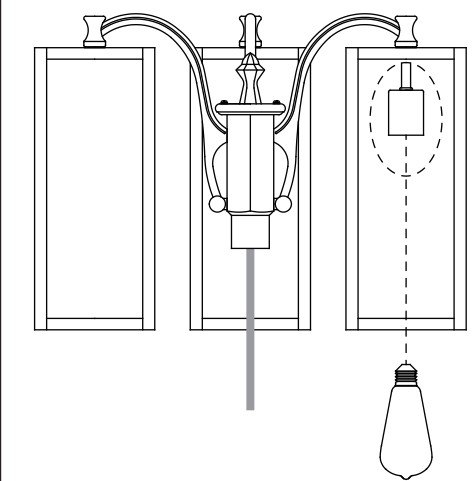

## STEP 6

Pass through the **electric wire** into **decorative pillar(top)** and **decorative pillar(middle)**. Secure the **decorative pillar(top)** into **centre pillar**, then secure the **decorative pillar(middle)** into **decorative pillar(bottom)**.

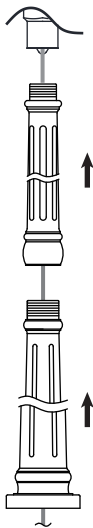

## STEP 7

Pass through the **electric wire** into **decorative pillar(bottom)**, attach the **decorative pillar (bottom)** onto **decorative pillar (middle)** using **screws(thick)**.

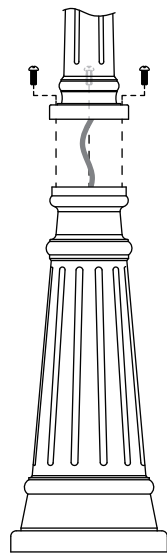

## STEP 8

Connect the live wire, neutral wire and ground wire with the supplied **wire nuts**. Secure with electrical tape(not included).

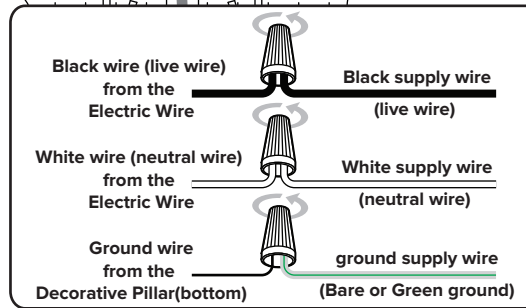
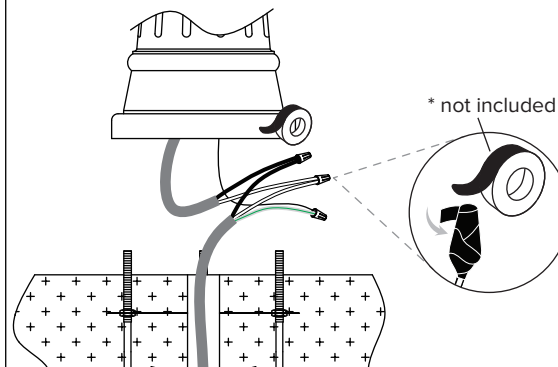

## STEP 9

Attach the **decorative pillarto (bottom)** to the **iron hook** through screw holes, and secure it with **big cap nuts**.

