

ASSEMBLY INSTRUCTION

DINING TABLE + DINING BENCH + DINING CHAIRS

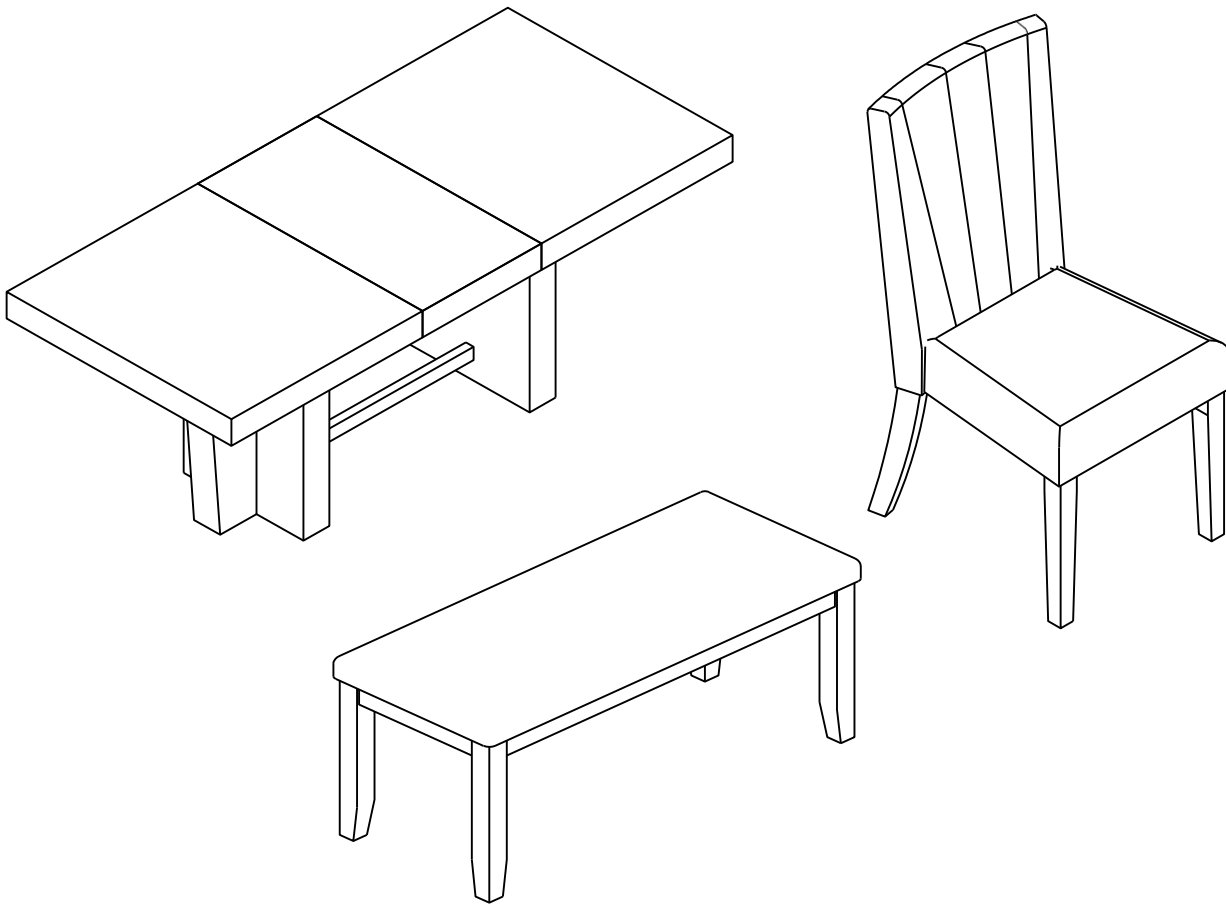

N717P465622
N717P465623
N717P465624

IMPORTANT NOTE:

- 1: PLACE ALL PARTS ON A CLEAN AND SMOOTH SURFACE SUCH AS A OR CARPET TO AVOID THE PARTS FROM BEING SCRATCHED.**
- 2: BEFORE YOU BEGIN, KINDLY FOLLOW THE ASSEMBLY INSTRUCTIONS STEP BY STEP.**
- 3: DO NOT TIGHTEN ALL SCREWS AND BOLTS UNTIL THE TABLE, BENCH AND CHAIRS ARE FULLY SET - UP.**

NOTICE DE MONTAGE

TABLE À MANGER + BANC DE SALLE À MANGER + CHAISES DE SALLE À MANGER

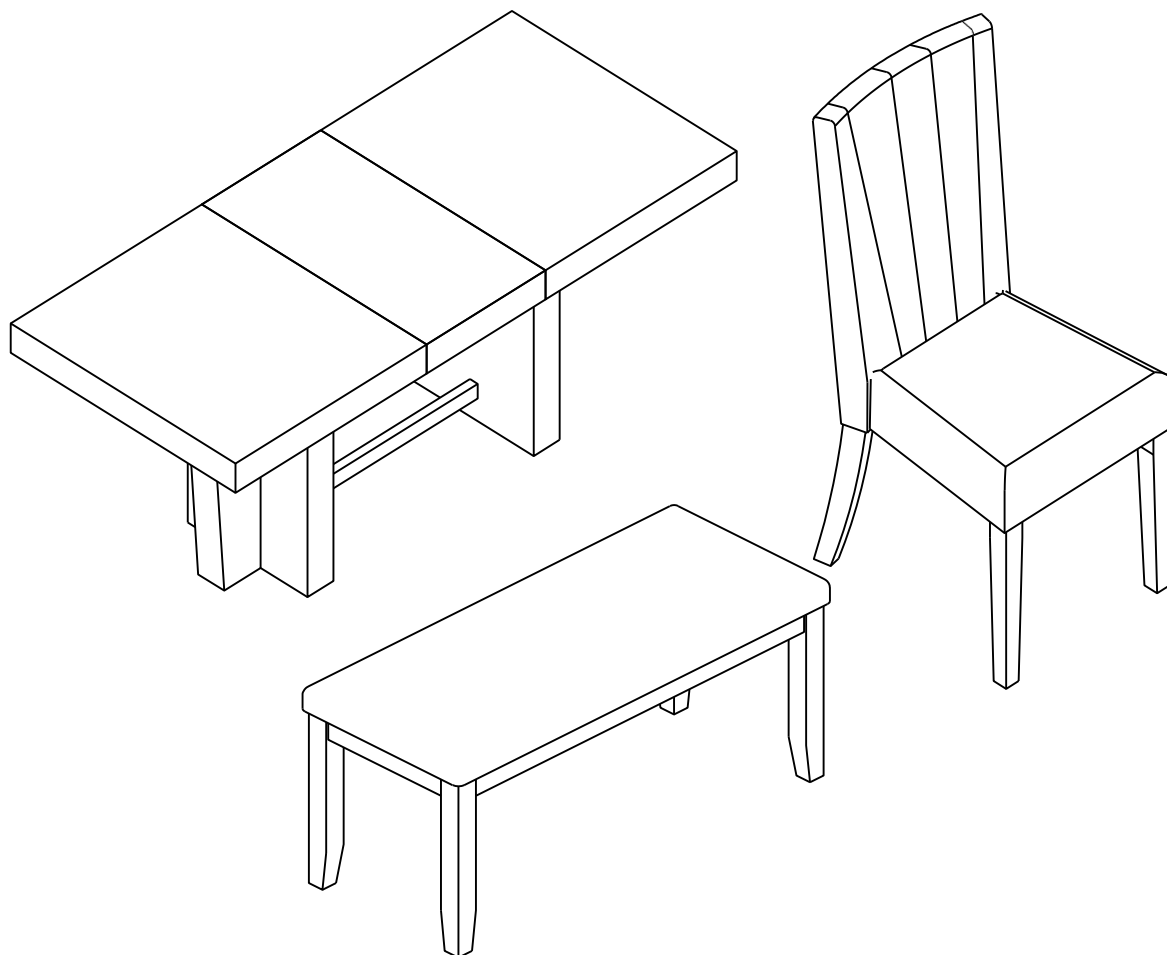

N717P465622

N717P465623

N717P465624

NOTE IMPORTANTE :

- 1: PLACEZ TOUTES LES PIÈCES SUR UNE SURFACE PROPRE ET LISSE, COMME UN TAPIS OU UNE MOQUETTE, AFIN D'ÉVITER DE LES RAYER.
- 2: AVANT DE COMMENCER, VEUILLEZ SUIVRE LES INSTRUCTIONS DE MONTAGE ÉTAPE PAR ÉTAPE.
- 3: NE SERREZ PAS COMPLÈTEMENT TOUTES LES VIS ET TOUS LES BOULONS AVANT QUE LA TABLE, LE BANC ET LES CHAISES NE SOIENT ENTIÈREMENT ASSEMBLÉS.

CARTON CONTENT

N717P465622

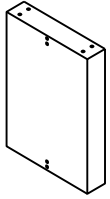

② x1

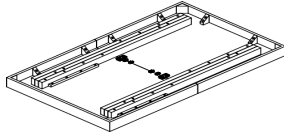

⑤ x1

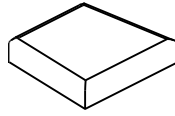

⑧ x1

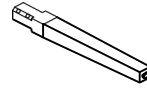

⑨ x2

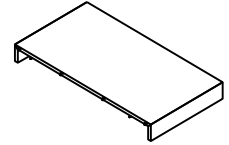

⑥ x1

N717P465623



① x2

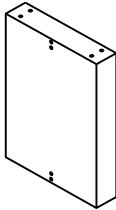

② x1

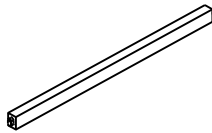

④ x1

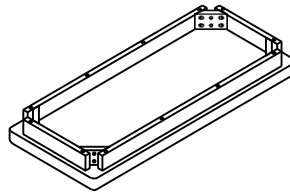

⑩ x1

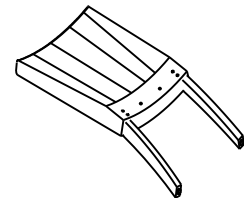

⑦ x1

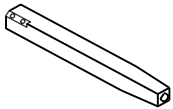

⑪ x4

N717P465624

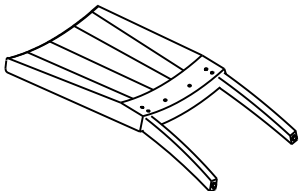

⑦ x3

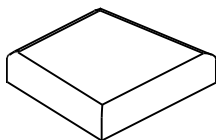

⑧ x3

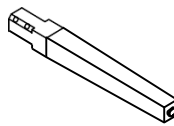

⑨ x6

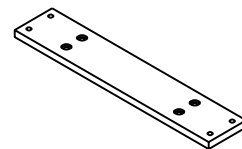







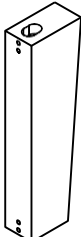
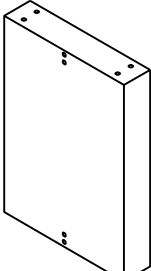
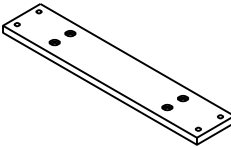
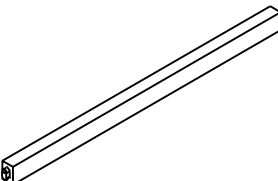
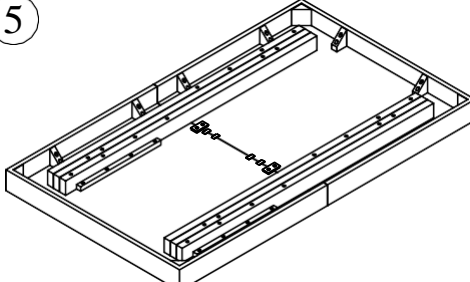
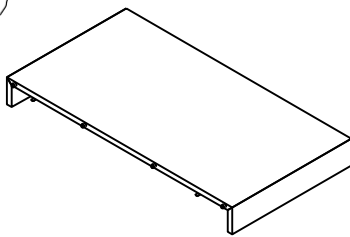
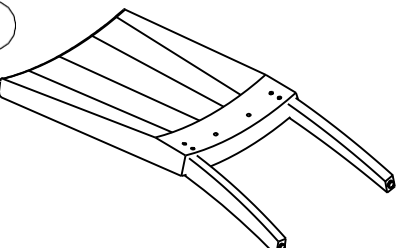
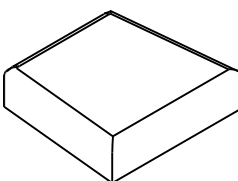
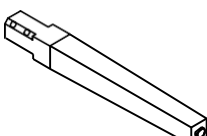
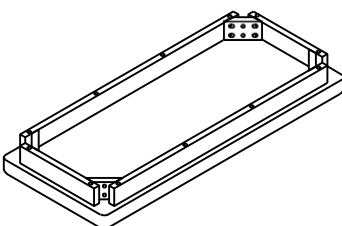
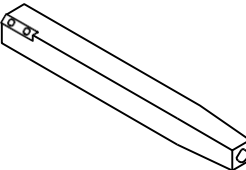

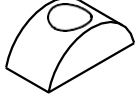

③ x2

Hardware table +
bench + 4 chairs

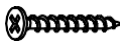
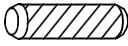
Part List / Liste Des

<p>1</p> 	<p>2</p> 	<p>3</p> 
<p>SUPPORT LEGS TABLE/ PIEDS DE SUPPORT DE TABLE (2 pcs)</p>	<p>TABLE LEGS/ PIEDS DE TABLE (2 pcs)</p>	<p>SUPPORT BAR/ BARRE DE SUPPORT (2 pcs)</p>
<p>4</p> 	<p>5</p> 	<p>6</p> 
<p>MIDDLE BAR/ BARRE CENTRALE (1 pc)</p>	<p>TOP TABLE/ PLATEAU DE TABLE (1 pc)</p>	<p>TOP TABLE LEAF/ ALLONGE DE TABLE (1 pc)</p>
<p>7</p> 	<p>8</p> 	<p>9</p> 
<p>BACK FRAME/ CADRE ARRIERE (4 pcs)</p>	<p>SEAT FRAME/ CADRE D'ASSISE (4pcs)</p>	<p>CHAIR LEGS/ PIEDS DE CHAISE (8 pcs)</p>
<p>10</p> 	<p>11</p> 	
<p>BENCH FRAME/ CADRE DE BANC (1 pc)</p>	<p>BENCH LEGS/ PIEDS DE BANC (4 pcs)</p>	

Hardware List/ Liste Le Quincaillerie

<p>A</p>  <p>5/16"x40 mm</p>	<p>B</p> 	<p>C</p>  <p>5/16"x11 mm</p>
<p>BOLT/ BOULON (20 pcs)</p>	<p>ARC WASHER/ RONDELLE BOMBÉE (4 pcs)</p>	<p>LOCK WASHER/ RONDELLE FREIN (16 pcs)</p>
<p>D</p>  <p>5/16"x19 mm</p>	<p>E</p>  <p>4x58mm</p>	<p>F</p>  <p>4x40 mm</p>
<p>FLAT WASHER/ RONDELLE PLATE (16 pcs)</p>	<p>ALLEN KEY/ CLÉ ALLEN (3 pc)</p>	<p>PAN HEAD SCREW/ VIS À TÊTE BOMBÉE (2 pcs)</p>
<p>G</p>  <p>Ø10x30 mm</p>	<p>H</p>  <p>1/4"x75 mm</p>	<p>I</p>  <p>1/4"x60 mm</p>
<p>WOOD DOWEL/ CHEVILLE EN BOIS (4 pcs)</p>	<p>BOLT/ BOULON (16 pcs)</p>	<p>BOLT/ BOULON (24 pcs)</p>
<p>J</p>  <p>1/4"x35 mm</p>	<p>K</p>  <p>1/4"x11 mm</p>	<p>M</p>  <p>1/4"x19 mm</p>
<p>BOLT/ BOULON (8 pcs)</p>	<p>LOCK WASHER/ RONDELLE FREIN (48 pcs)</p>	<p>FLAT WASHER/ RONDELLE PLATE (48 pcs)</p>

ASSEMBLY TOOLS REQUIRED (NOT INCLUDED)

OUTILS D'ASSEMBLAGE REQUIS (NON INCLUS)



Detail View/Vue Détaillée

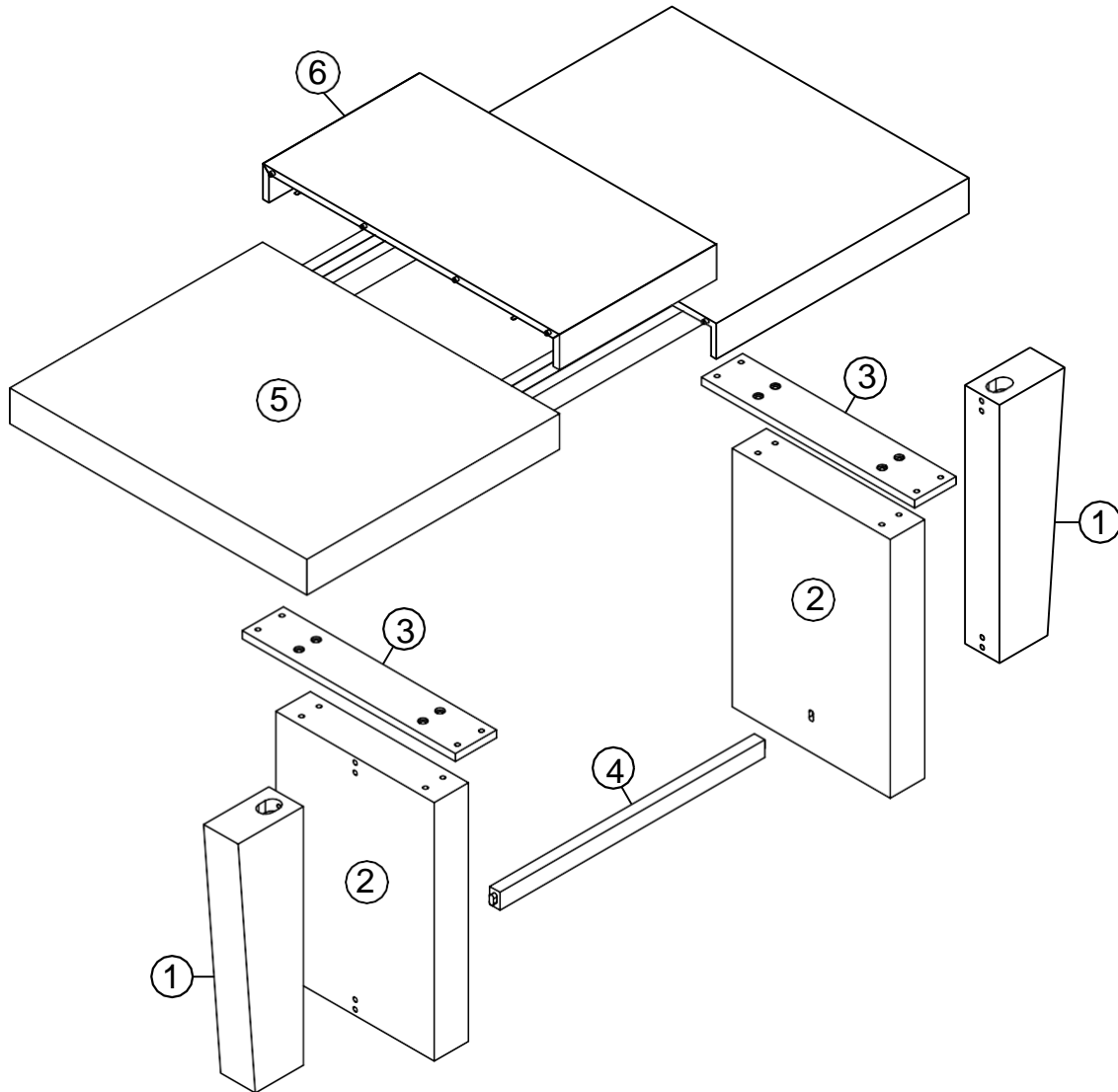

STEP/ ÉTAPE 1:

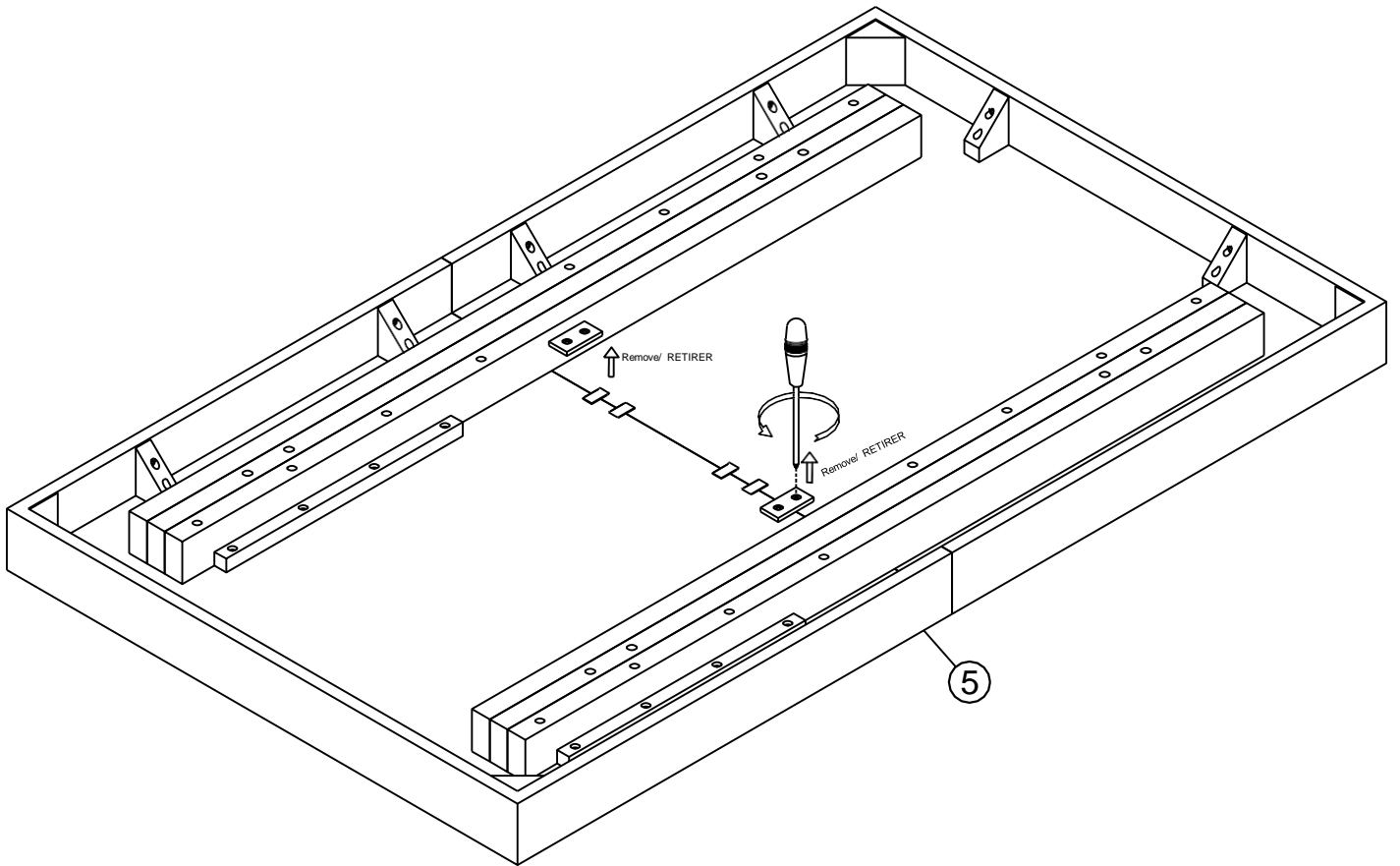

STEP/ ÉTAPE 2:

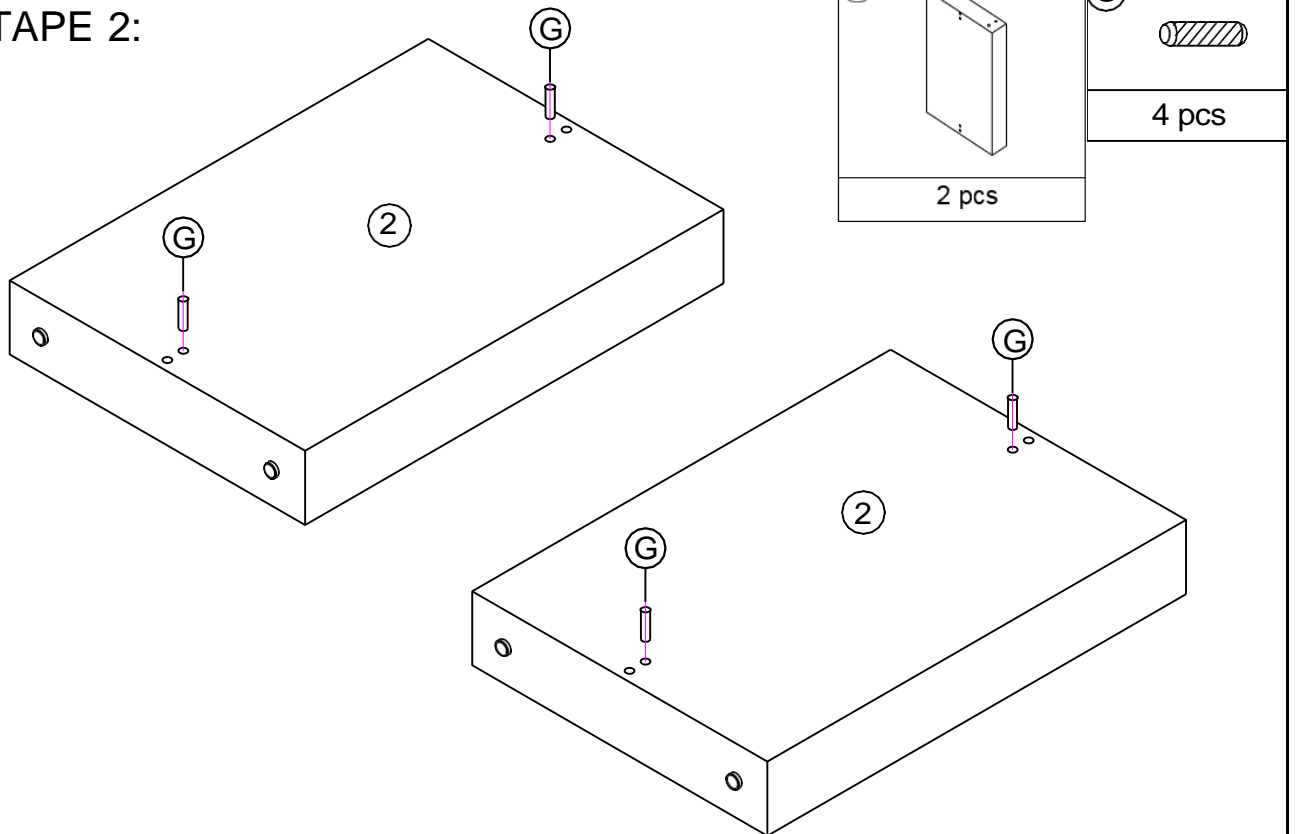

STEP/ ÉTAPE 3:

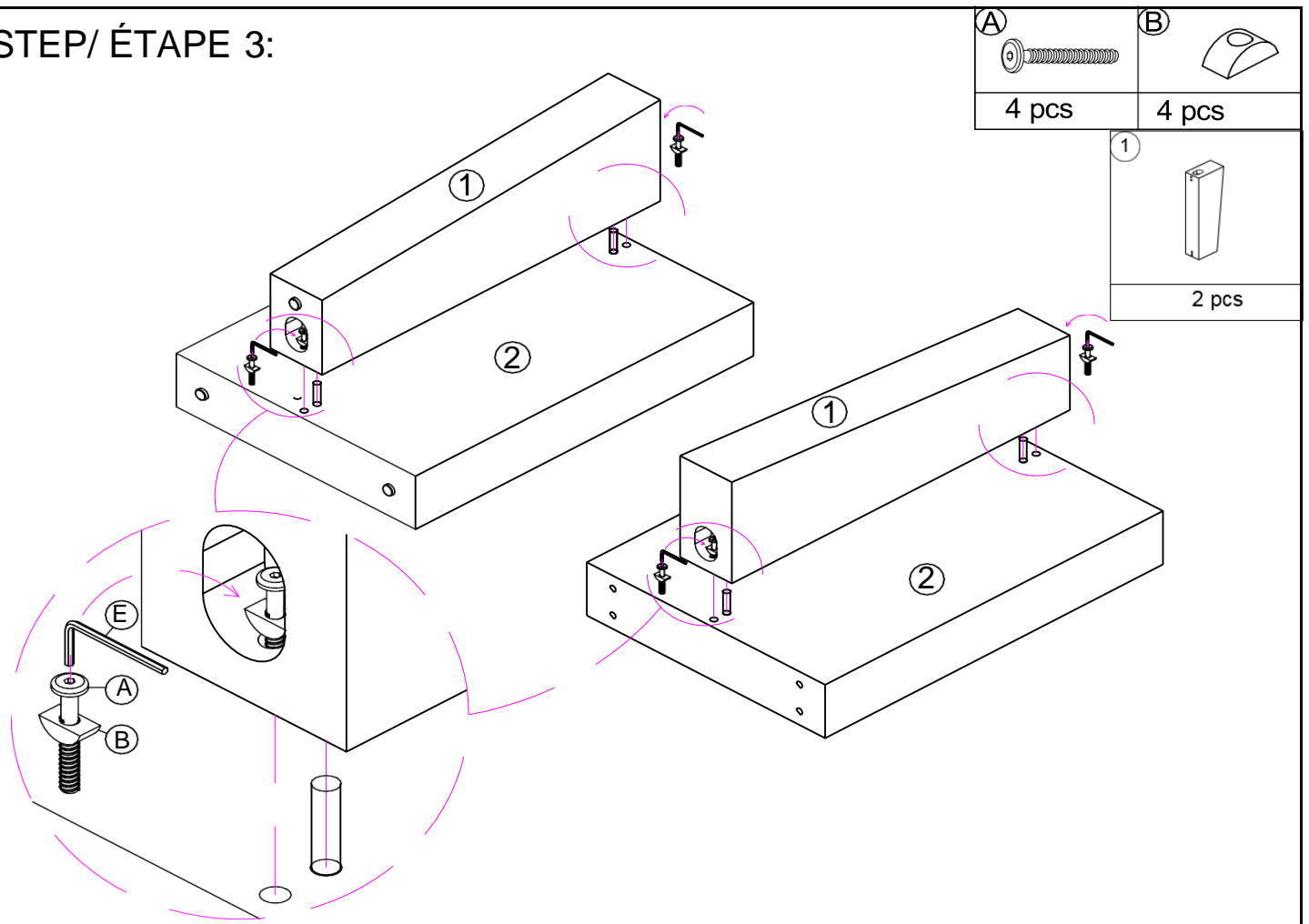

STEP/ ÉTAPE 4:

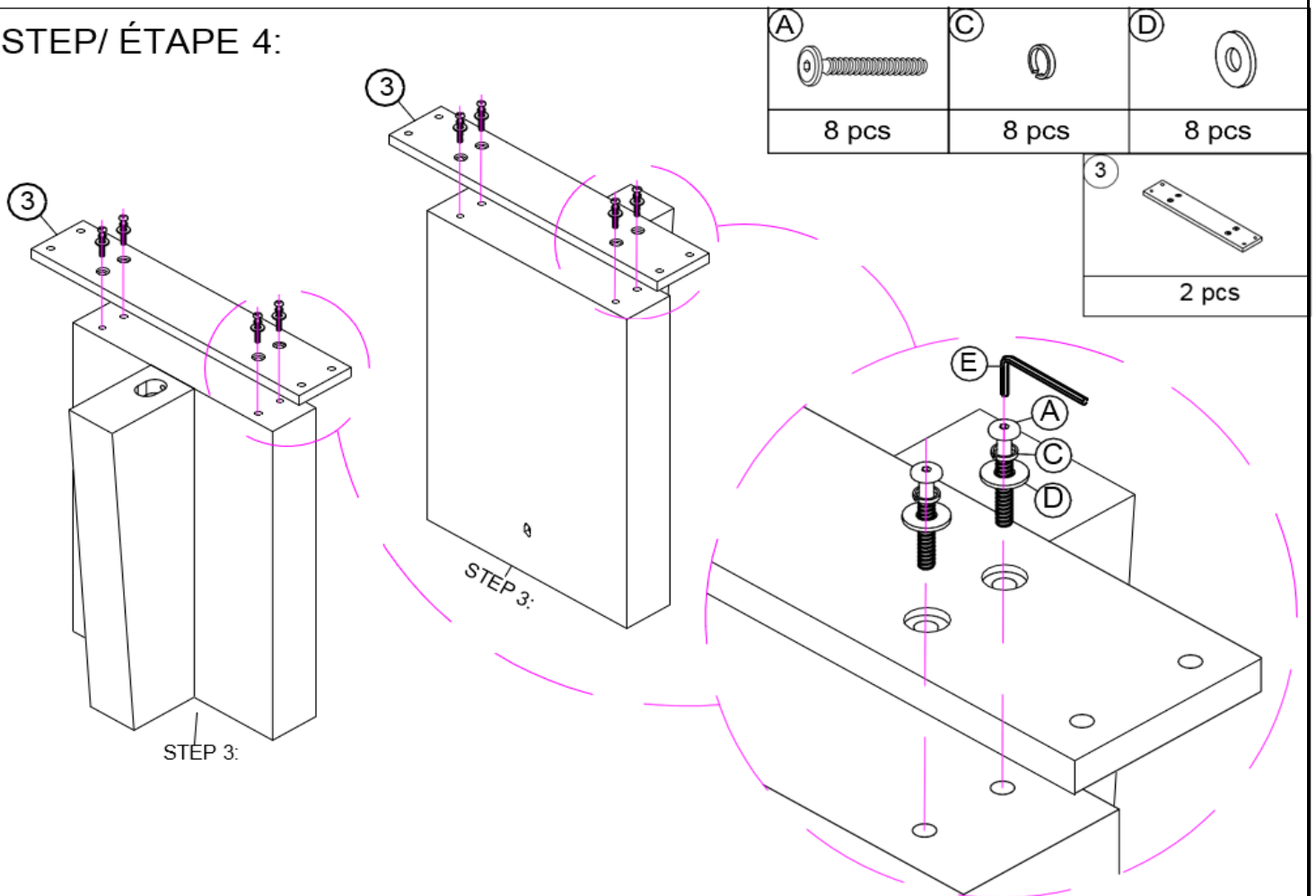

STEP/ ÉTAPE 5:

A	C	D
4 pcs	4 pcs	4 pcs

5
1 pcs

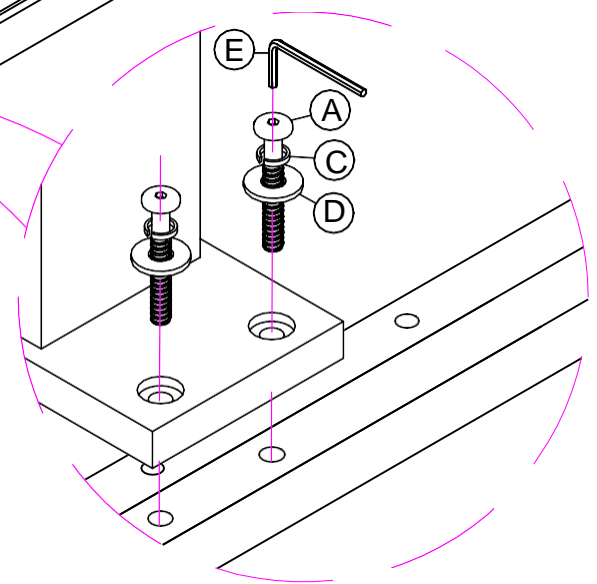
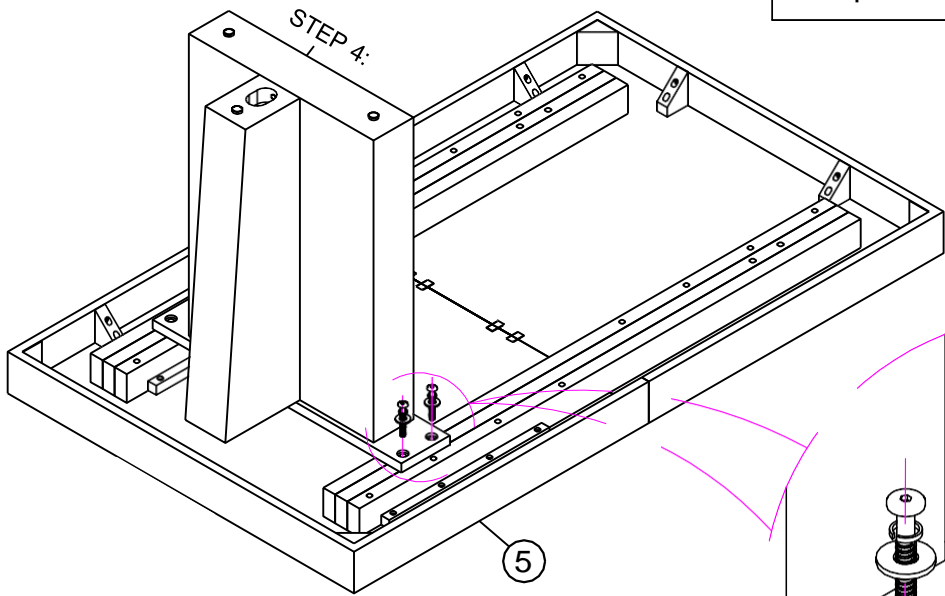

STEP/ ÉTAPE 6:

A	C	D
4 pcs	4 pcs	4 pcs

4	F
1 pcs	2 pcs

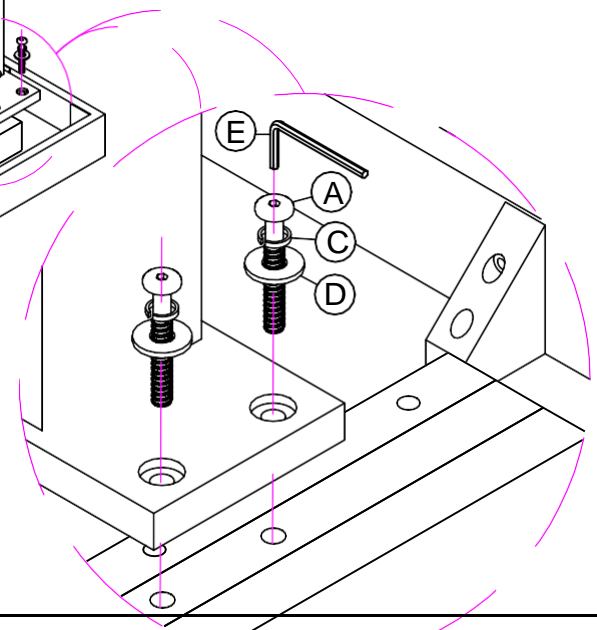
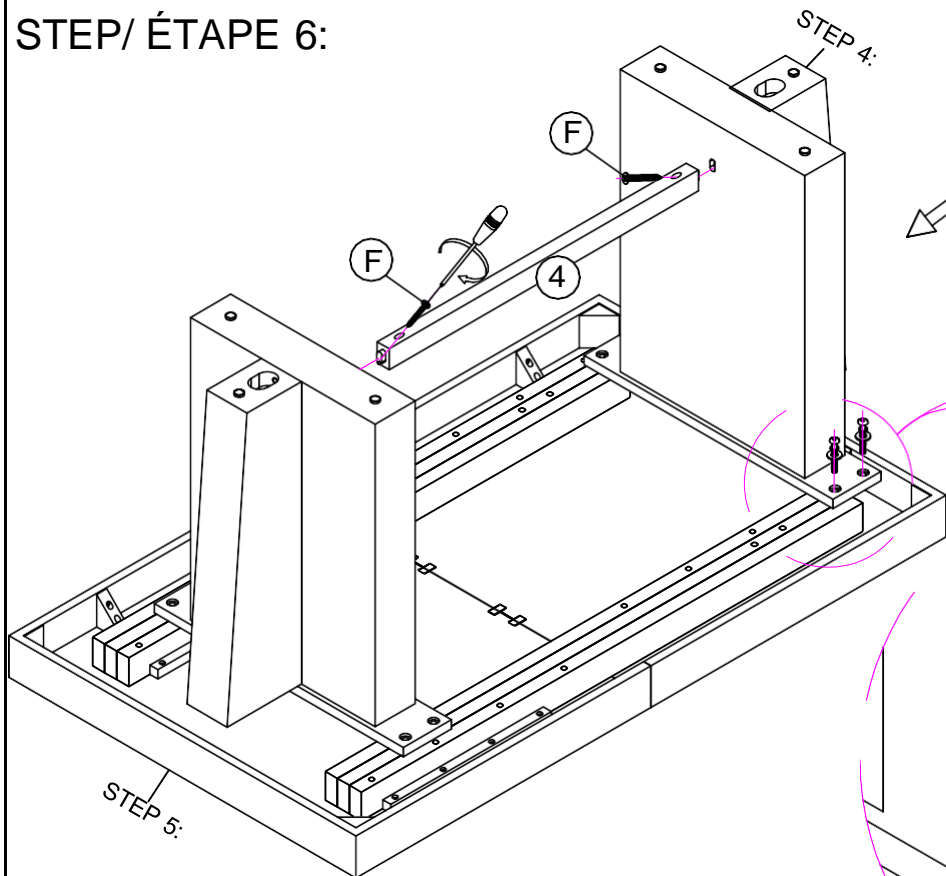

STEP/ ÉTAPE 7:

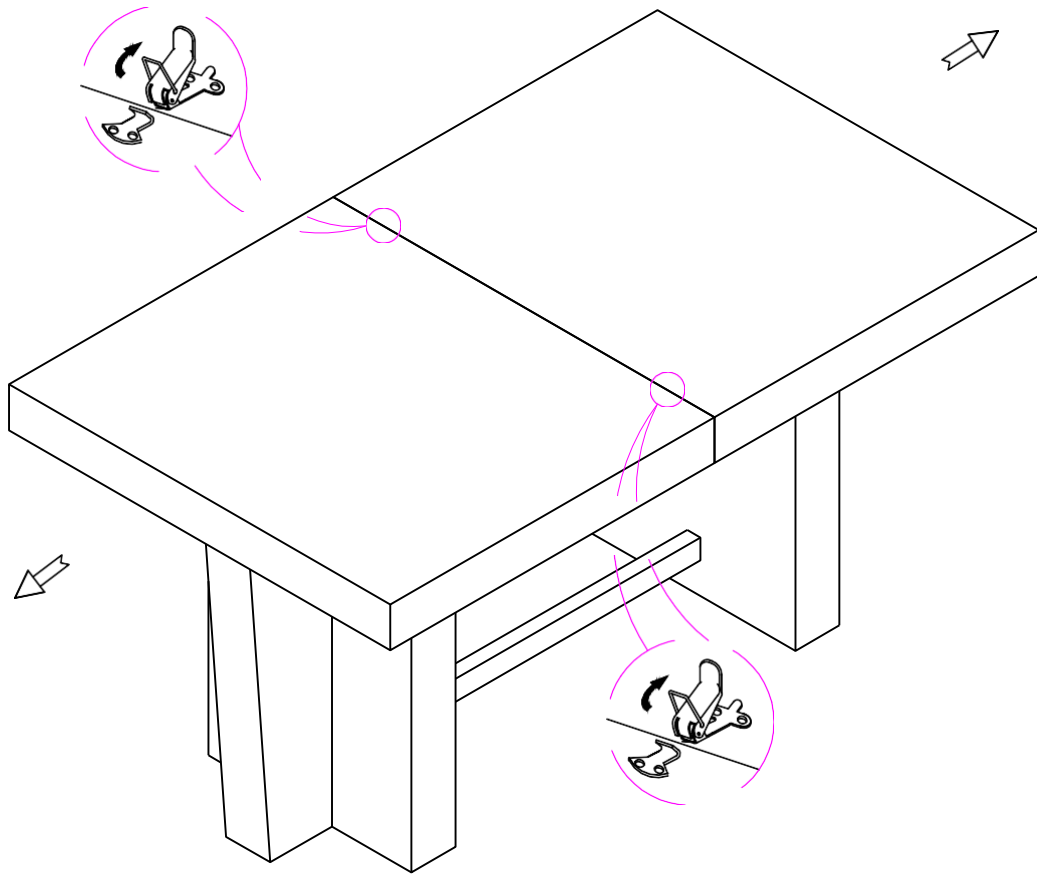

STEP/ ÉTAPE 8:

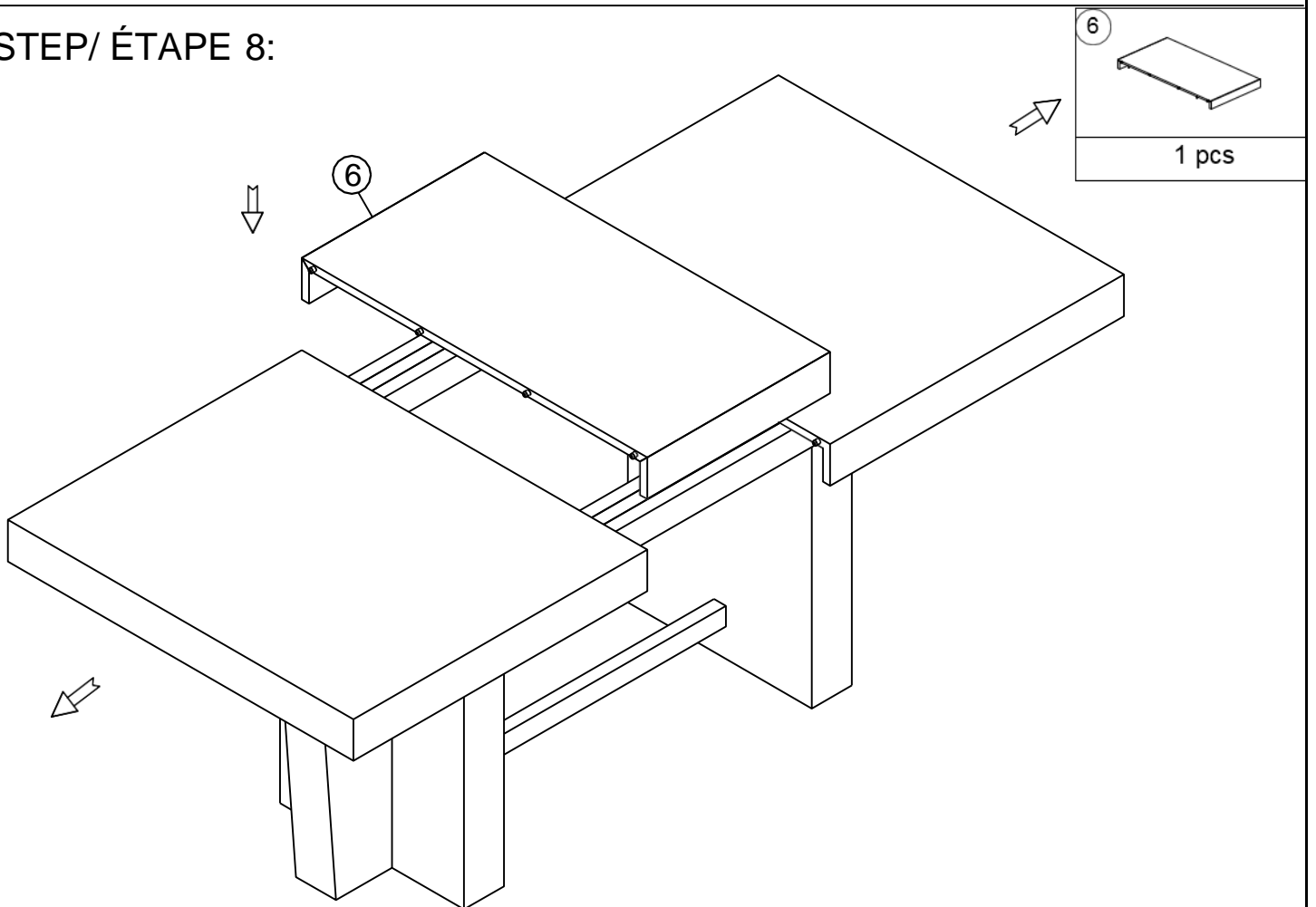

STEP/ ÉTAPE 9:

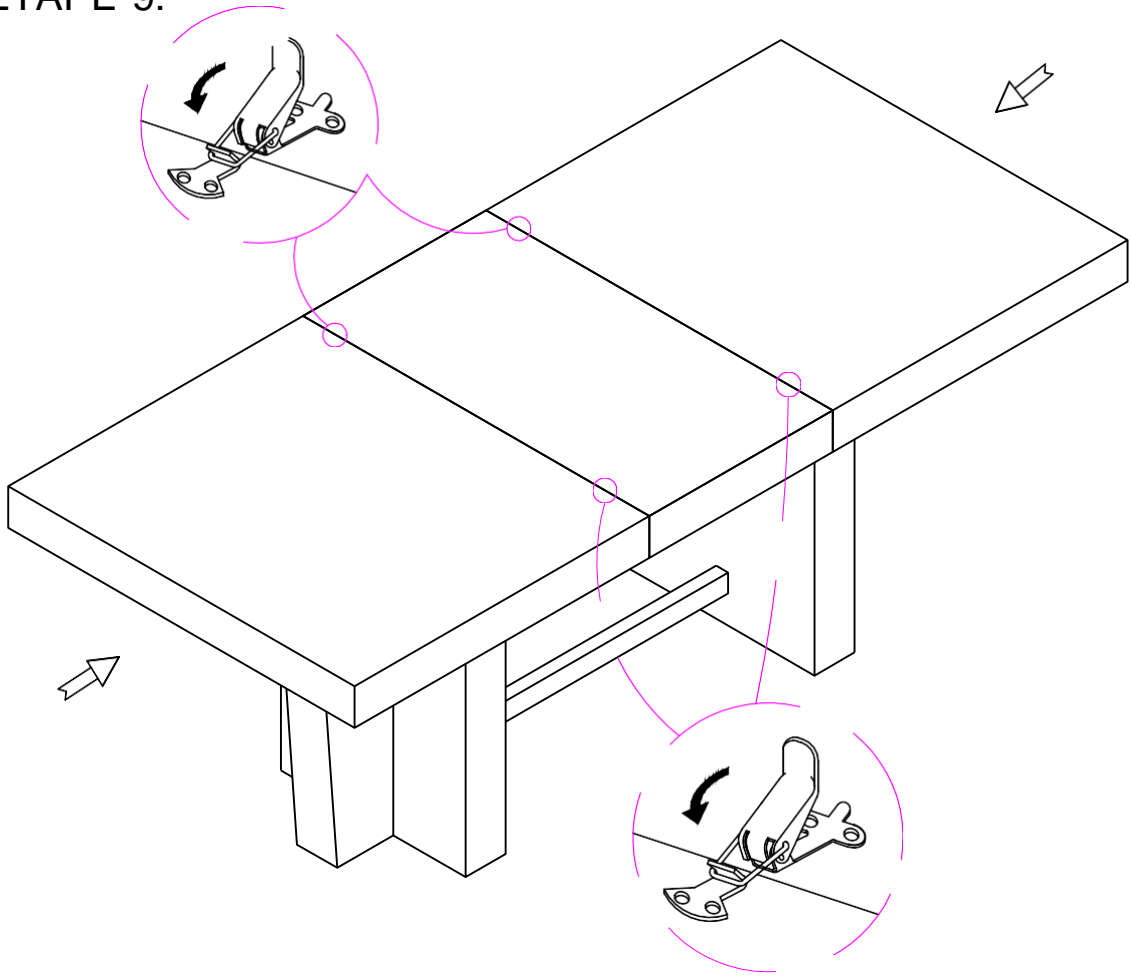

COMPLETED/ TERMINÉ:

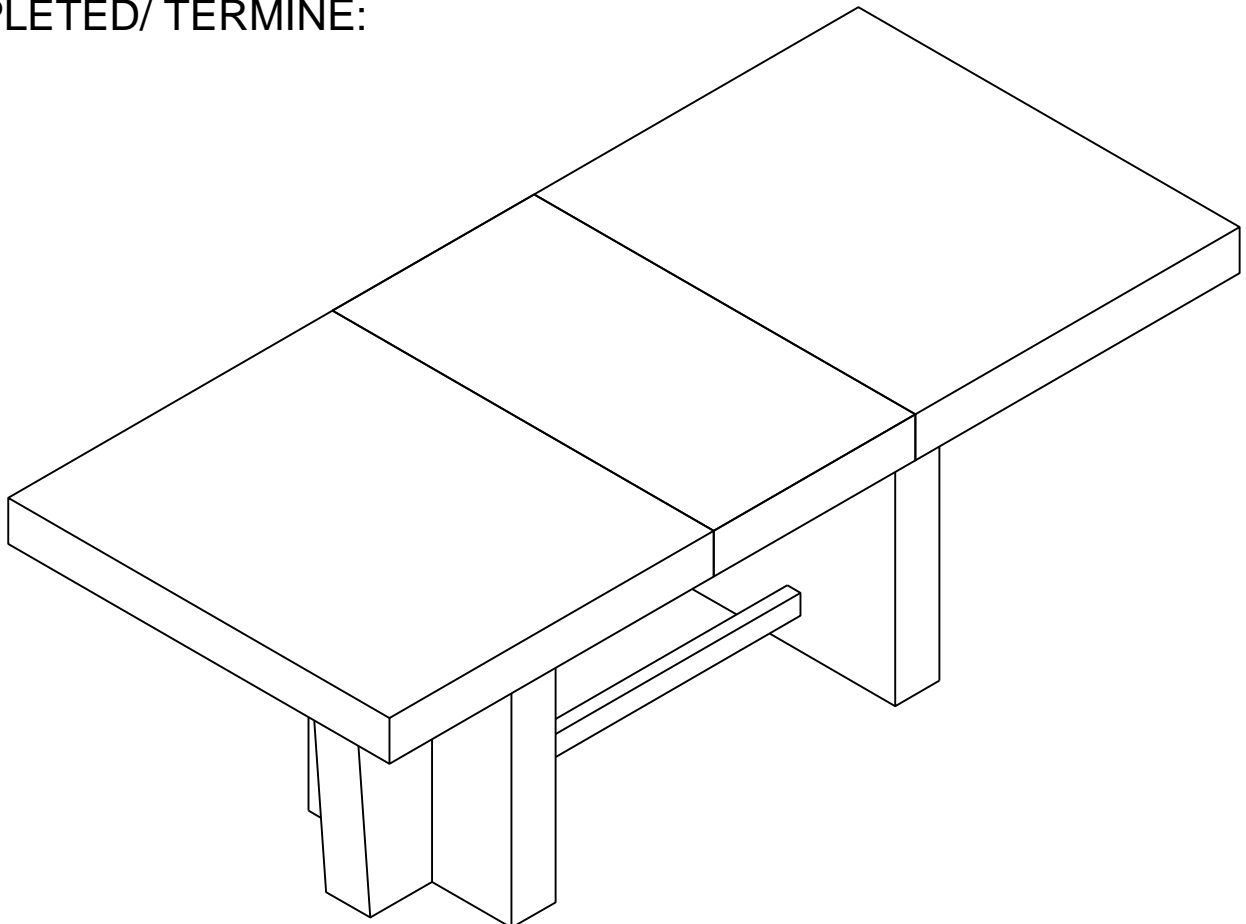

Detail View/Vue Détaillé

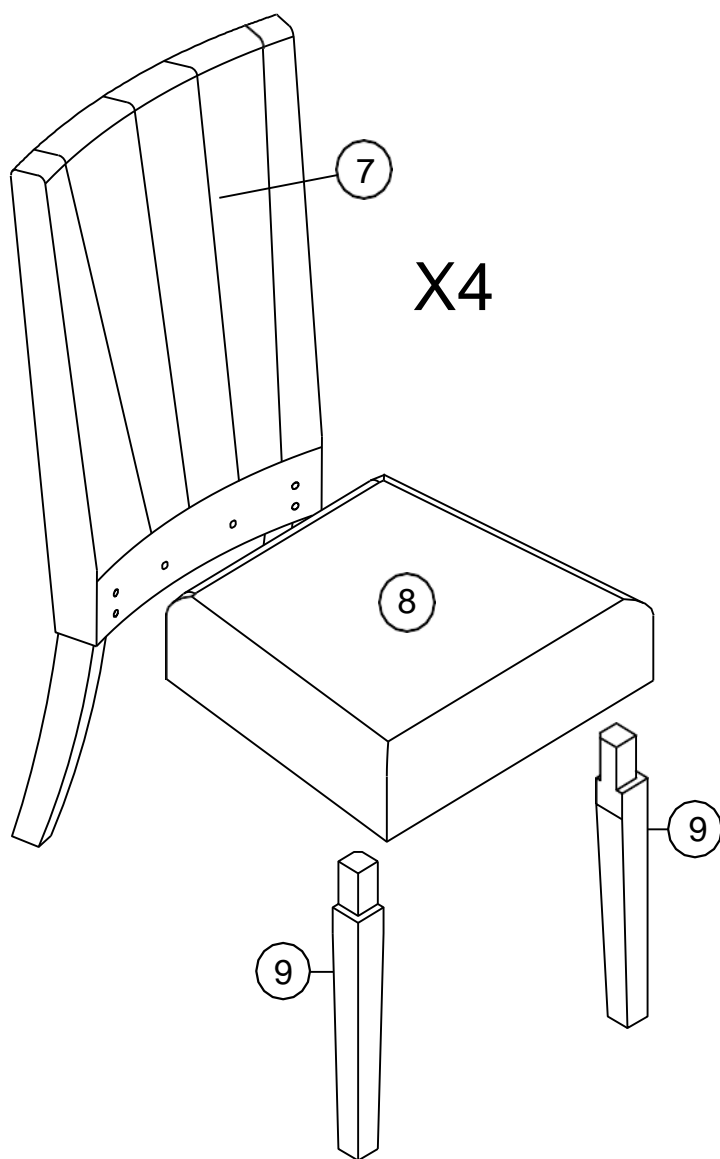

STEP/ ÉTAPE 1:

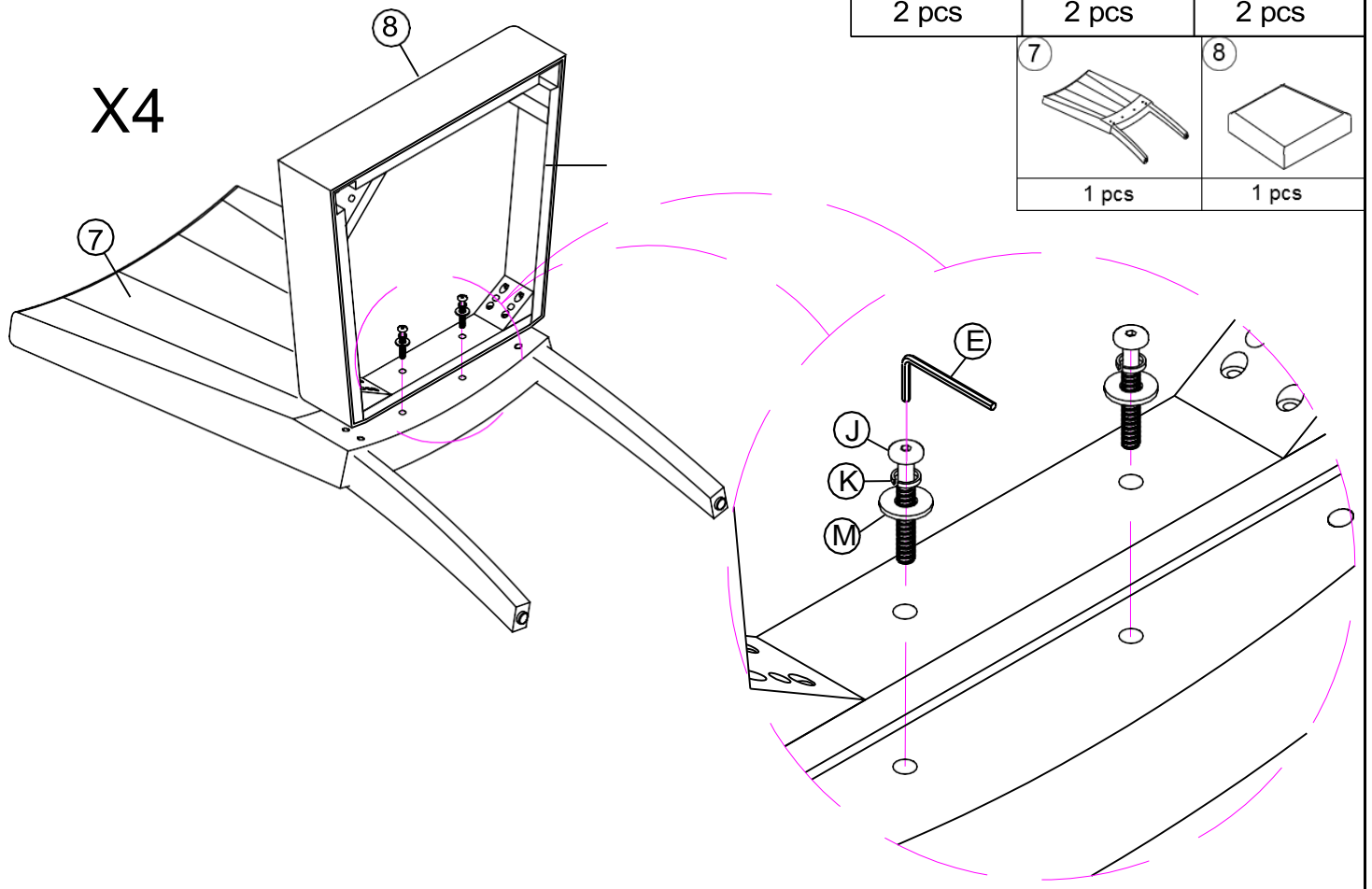

STEP/ ÉTAPE 2:

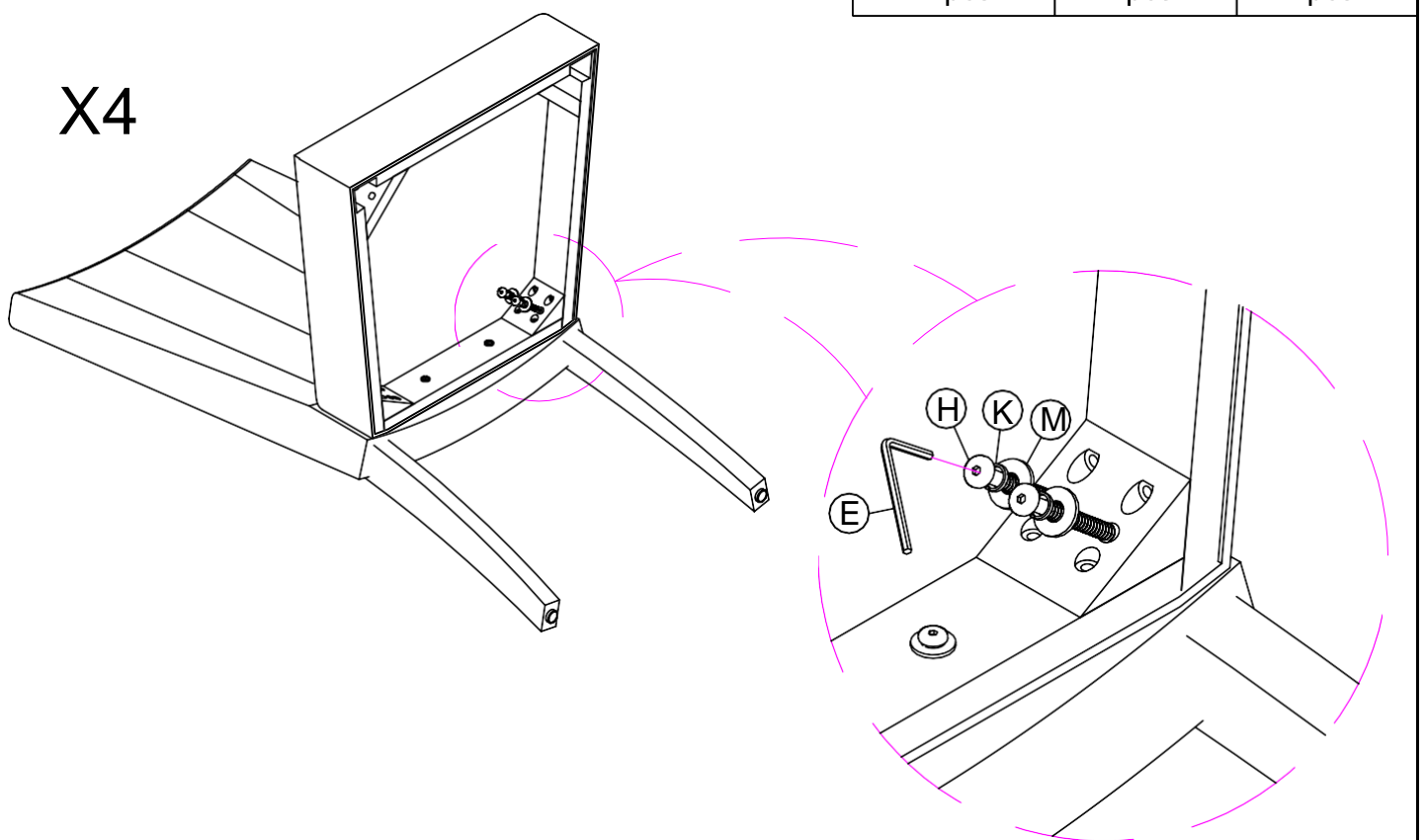

STEP/ ÉTAPE 3:

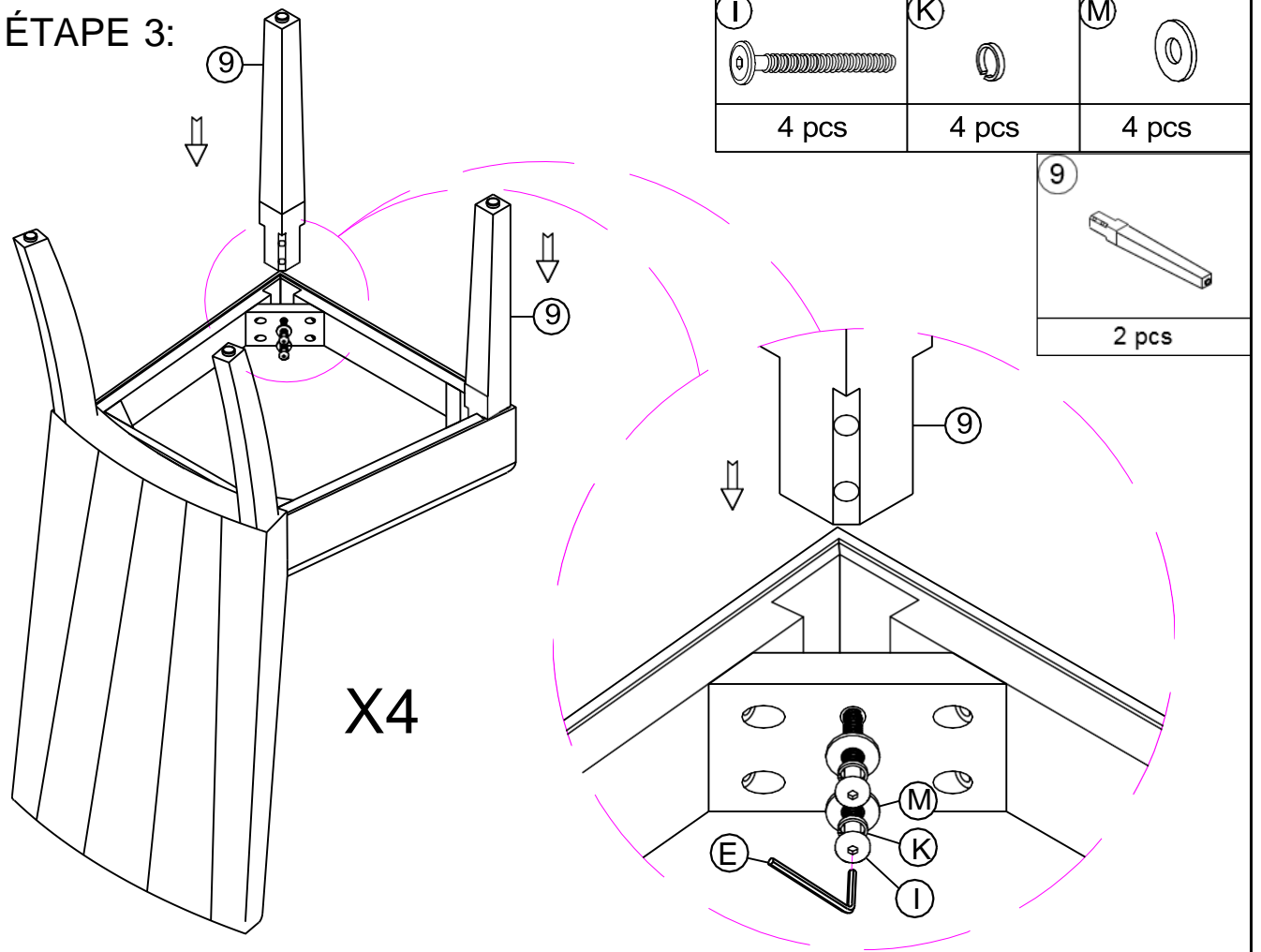

COMPLETED/ TERMINÉ:

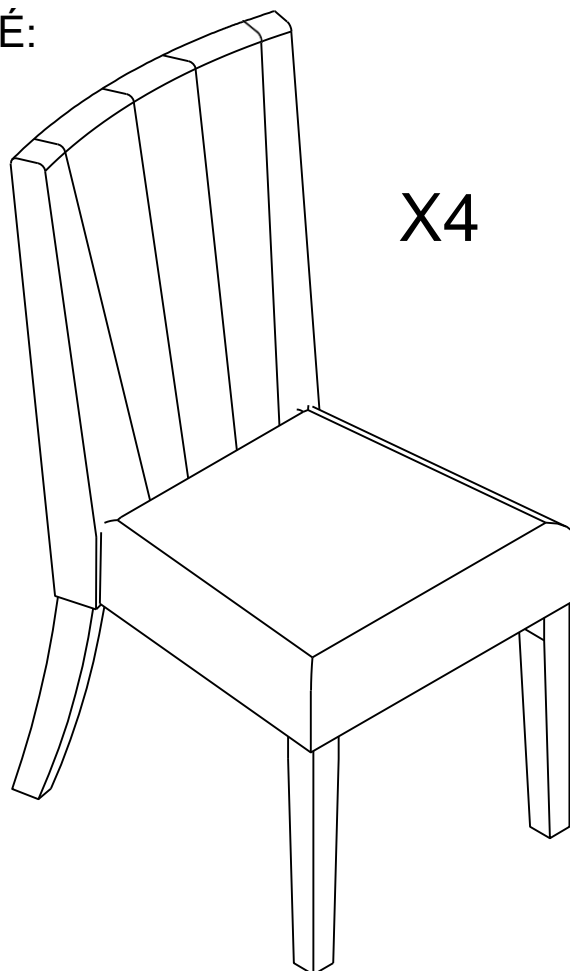

Detail View/Vue Détaillé

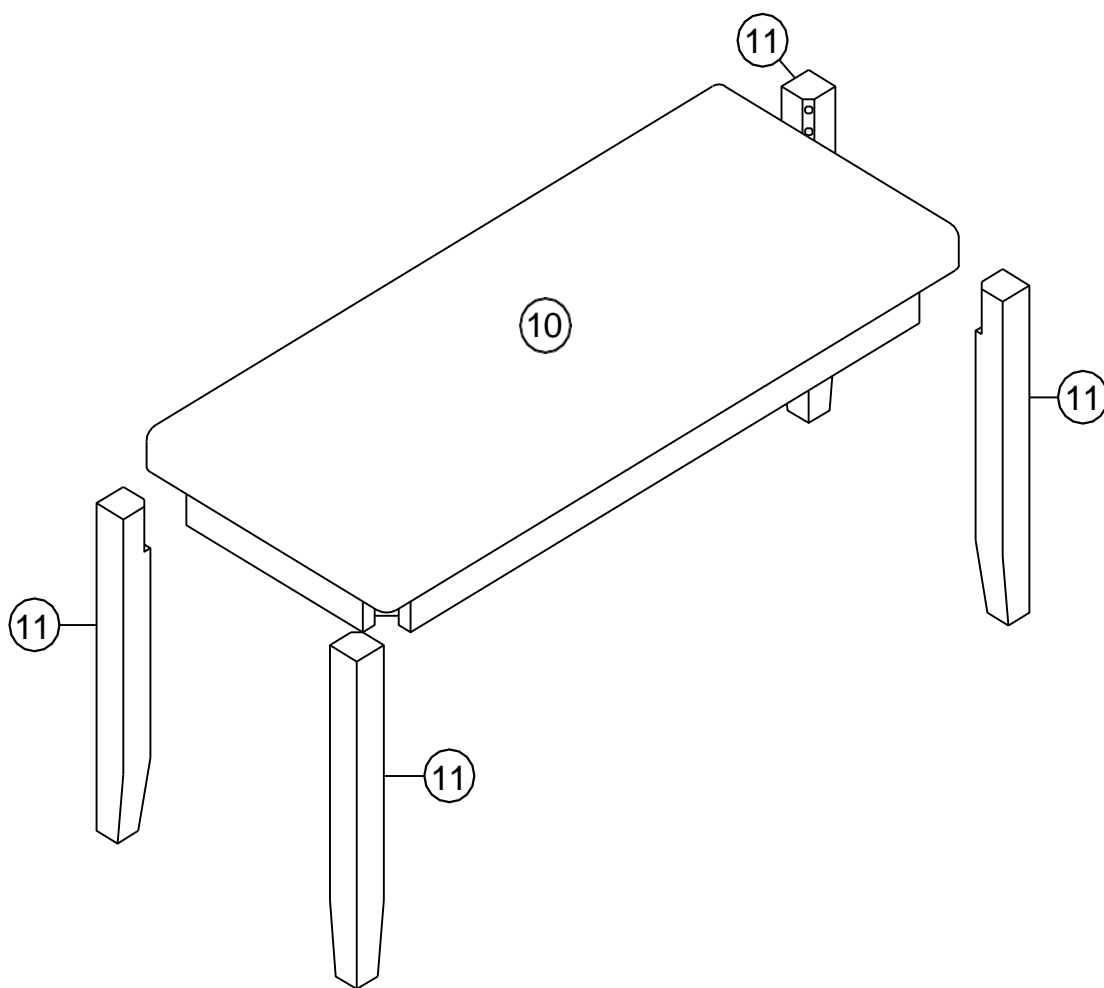

STEP/ ÉTAPE 1:

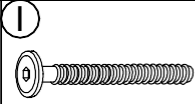
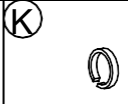
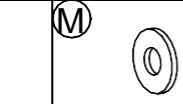
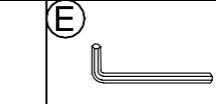
			
8 pcs	8 pcs	8 pcs	1 pcs

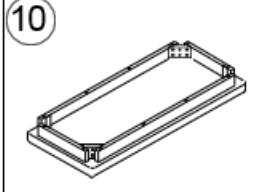
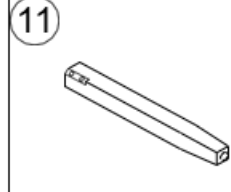
	
1 pcs	4 pcs

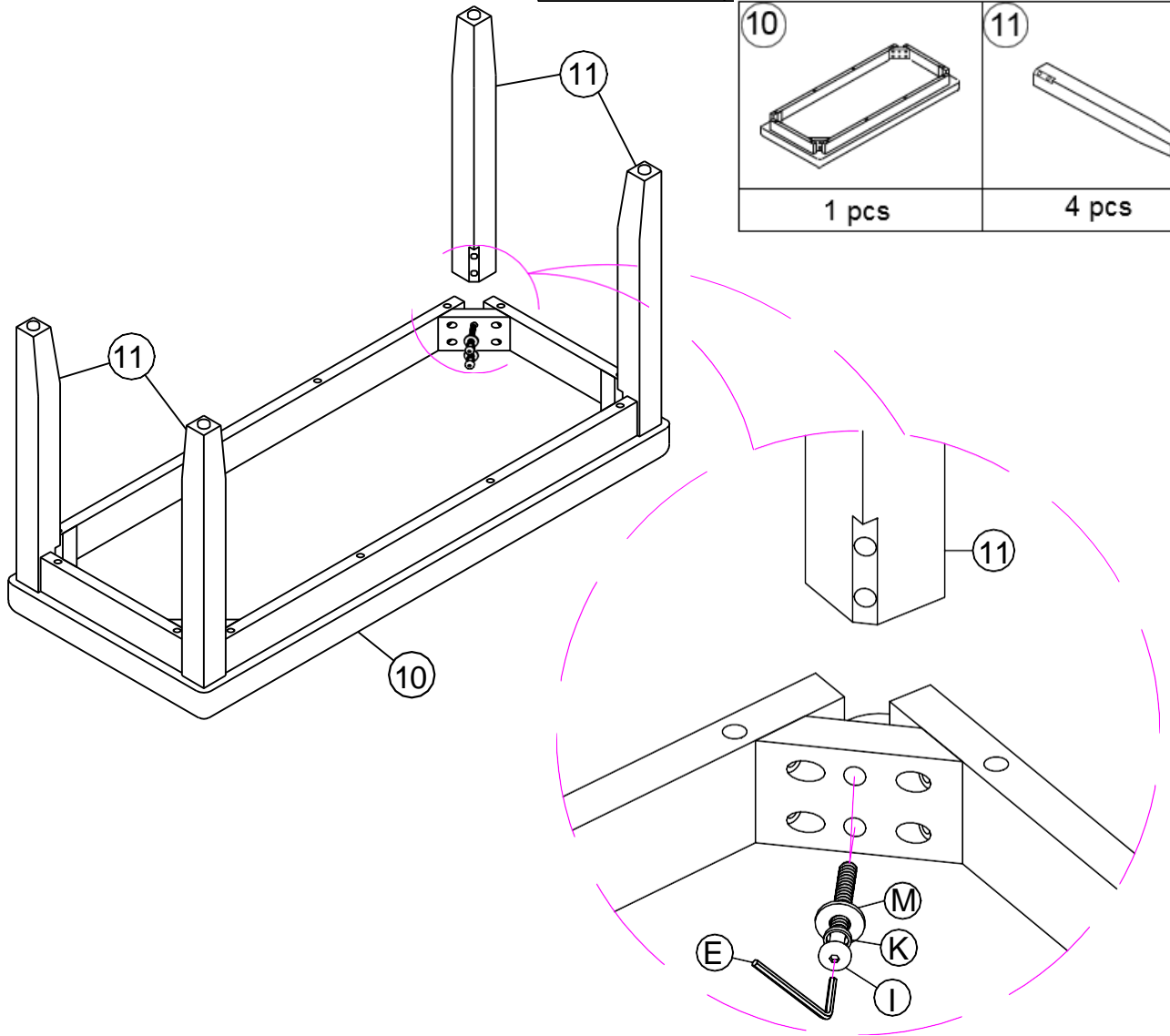

COMPLETED/ TERMINÉ:

