

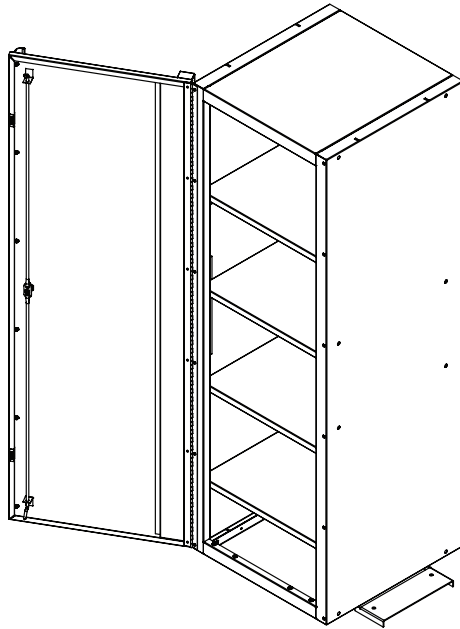

DX Series
19" Painted Steel Side Locker
with 4 Shelves



Model: DX192100SL

Extreme Tools, Inc.
740 Frontenac Road
Naperville, Illinois 60563
630.369.9303
CustomerService@extremetools.net
www.ExtremeTools.net

DX192100SL Parts List

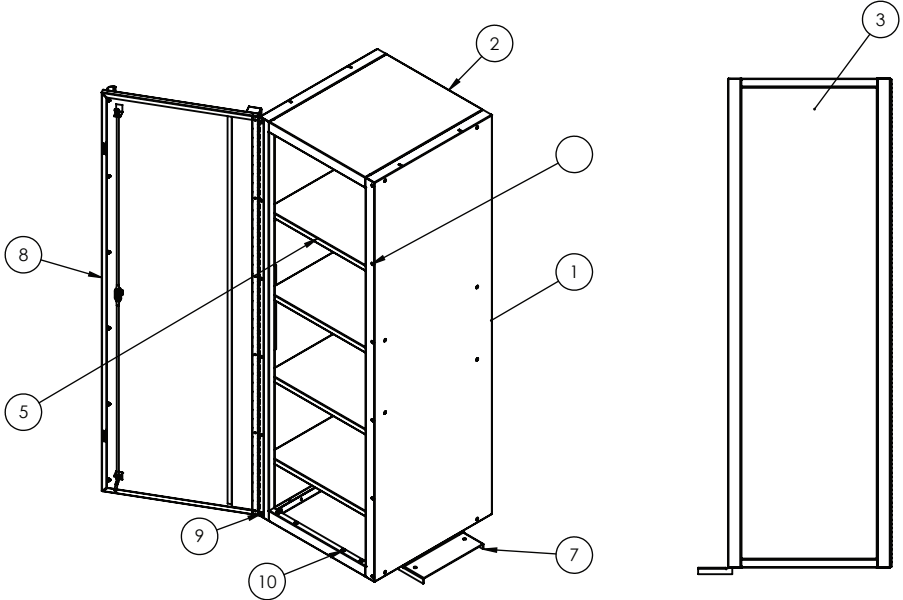

ITEM NO.	PART NUMBER	DESCRIPTION	QTY
1	DX192104SL-02	SIDE PANEL ASSEMBLY	2
2	DX192104SL-06	TOP/BOTTOM PANEL	2
3	DX192104SL-01	BACK PANEL	1
5	DX192104SL-07	ADJUSTABLE SHELF	4
6	Z-SCLIP-METAL	SHELF CLIP	8
7	DX192104SL-18	SUPPORT MOUNTING BRACKET	1
8	DX192104SL-08	DOOR ASSEMBLY	1
9	914201218	M4-.07 X 8mm FLAT HEAD SCREWS	11
10	Z-M8X16HBS	M8 X 16mm HEX BOLT	6
11	Z-M4X6MS	M4 X 6 MACHINE SCREW	36
12	Z-FWM8	M8 FLAT WASHER	6

Step1:

Place packing material or other soft surface down and lay back panel on soft surface.

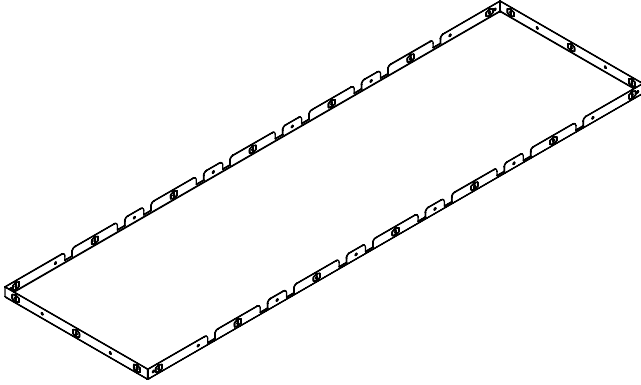

Step 2:

Position one side panel assembly perpendicular to the back panel.

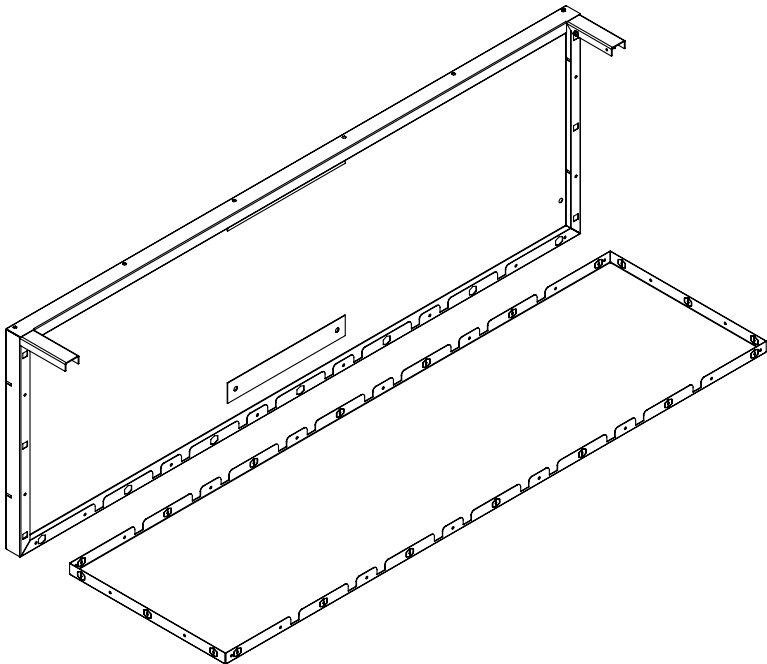

Step 3: Align holes and secure side panel using the pre-drilled holes and (8) M4 machine screws.

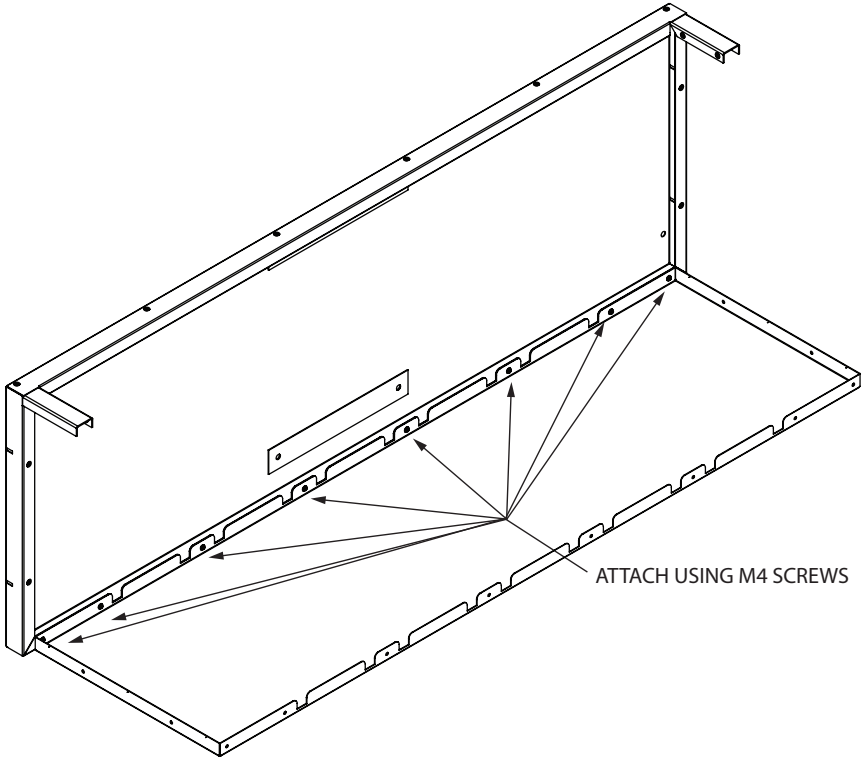

Step 4: Slide top/bottom panels through the slots and onto the gussets of the side panel.

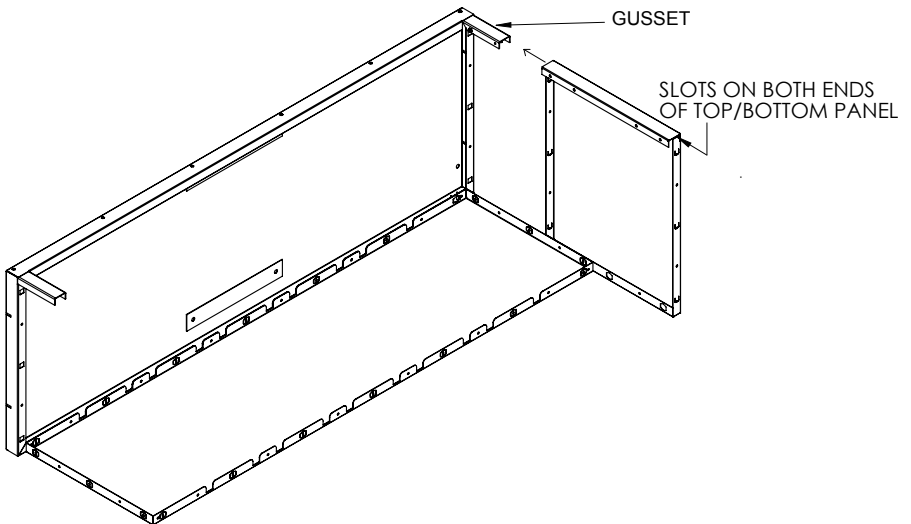

Step 5:

Secure top panel to side and back panels using (4) M4 screws through pre-drilled holes and into gussets.

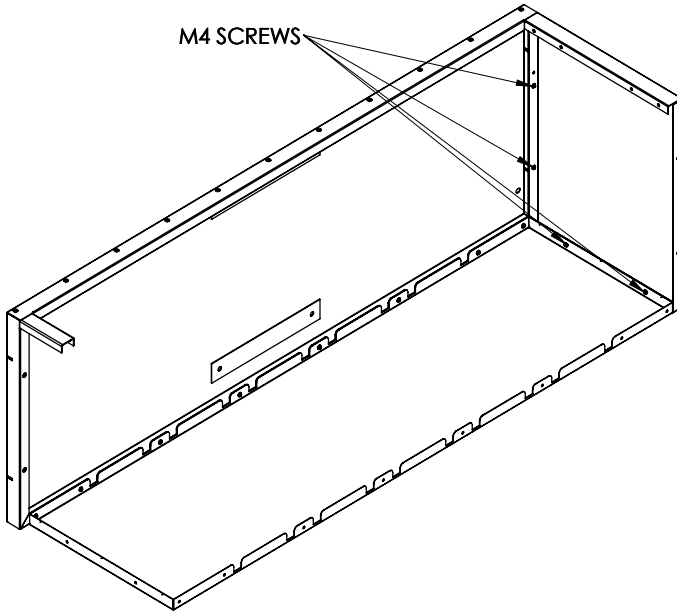

Step 6:

Repeat Step 5 to add the other top/bottom panel.

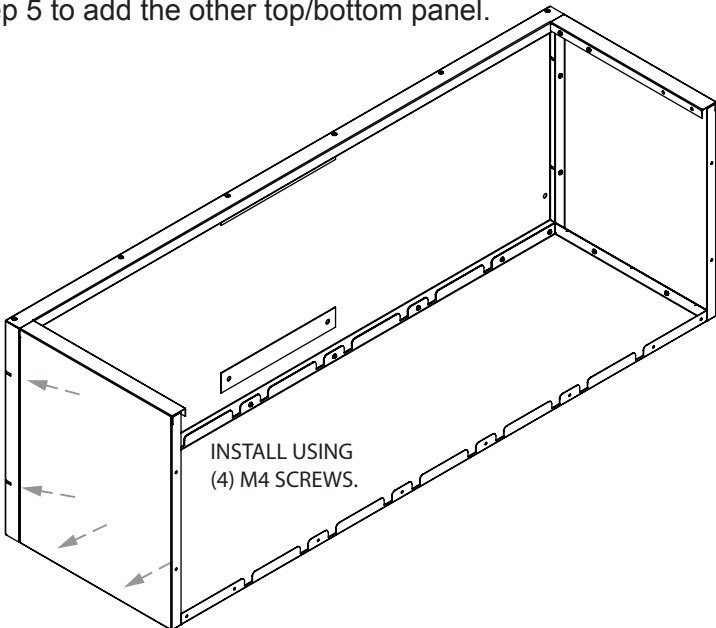

Step 7:

Add the other side panel assembly by inserting the attached gussets through the slots of the top and bottom panels. Secure the side panel to back panel and top and bottom panels using M4 screws as shown.

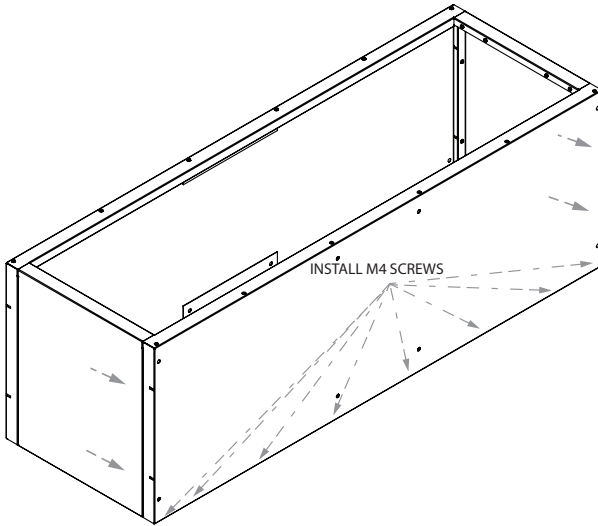

Step 8:

Locate the two Reinforcing Channels. Place a Reinforcing Channel into the Gusset in the top panel. Secure with (2) M4 screws at each end of the Reinforcing Channel. Repeat procedure for the bottom panel.

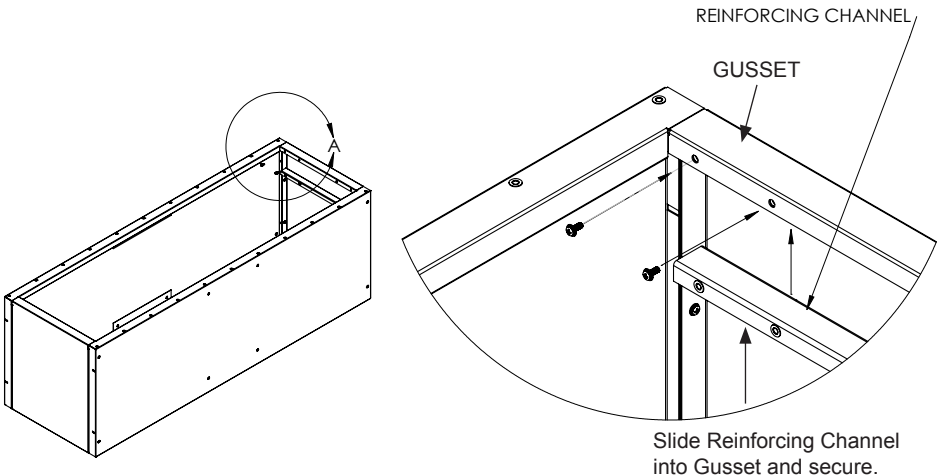

Step 9: **CAUTION! ENGAGE BRAKES ON CASTERS BEFORE PROCEEDING WITH THIS STEP!**

Set the assembled side locker body upright on the floor.

Attach the mounting bracket on the bottom support channel of the roller cabinet with (2) M8 x 16 Bolt & Washers.

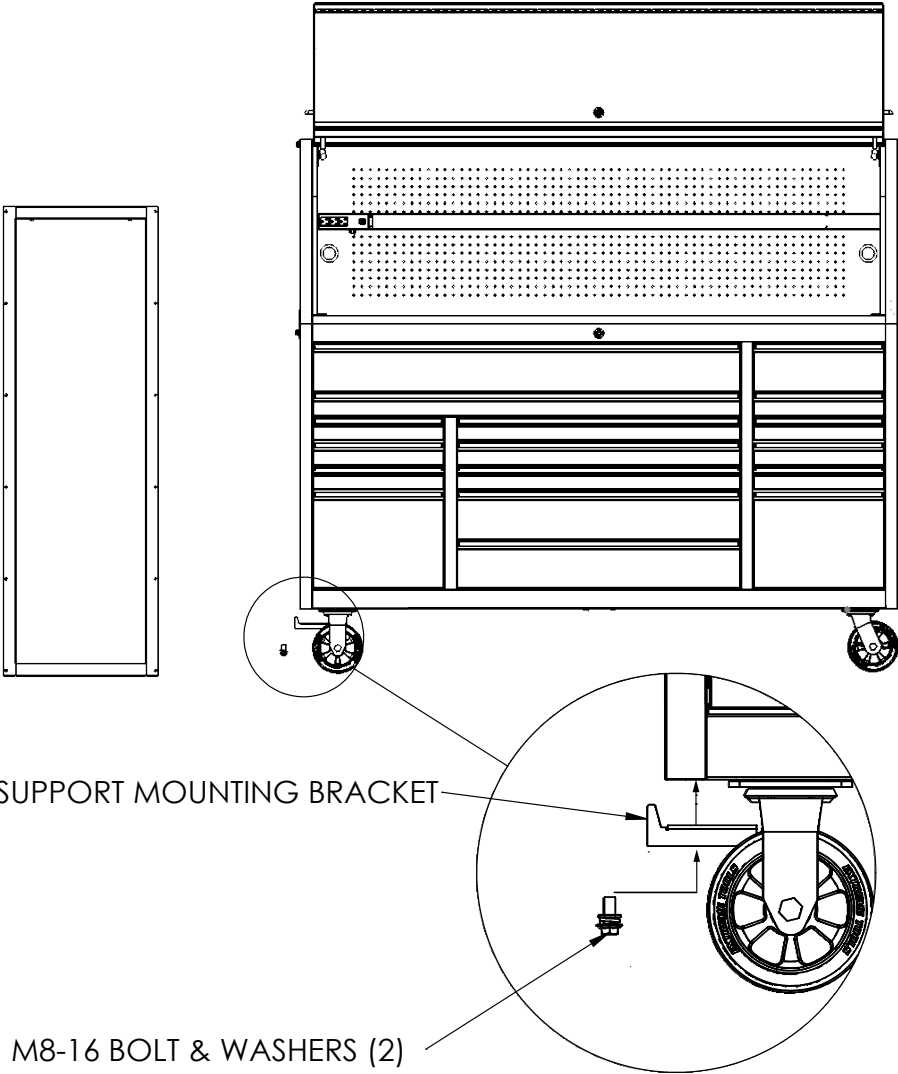

Step 10: **SIDE LOCKER IS HEAVY! AND REQUIRES ASSISTANCE TO LIFT INTO PLACE!**

Locate the slots on the bottom panel of the side locker. With assistance, lift and position the assembled side locker body onto the tabs of the support bracket. Make sure the slots on the bottom of side locker are fully engaged with the tabs of the support mounting bracket.

CONTINUE HOLDING THE SIDE CABINET IN PLACE WHILE GOING TO THE NEXT STEP!

SLOTS ON BOTTOM OF UNIT

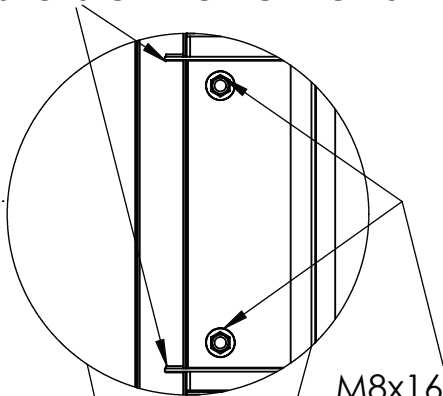

M8x16 BOLT & WASHERS

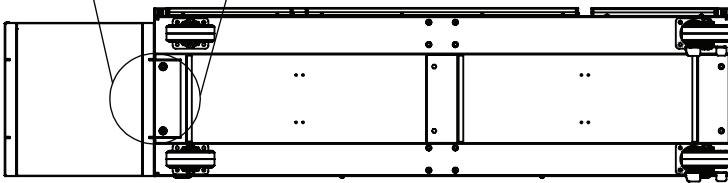
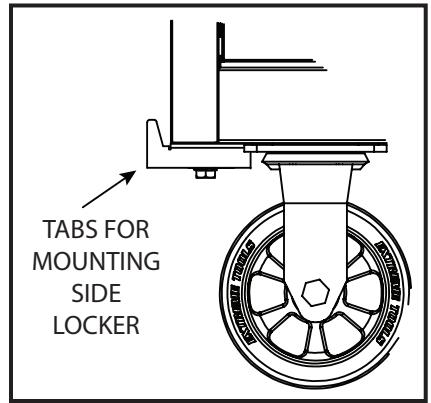

Step 11:

With the assistance of another person holding the side locker in place, secure side locker body to the roller cabinet and hutch (or chest) with (4) M8x20mm Hex Bolts.

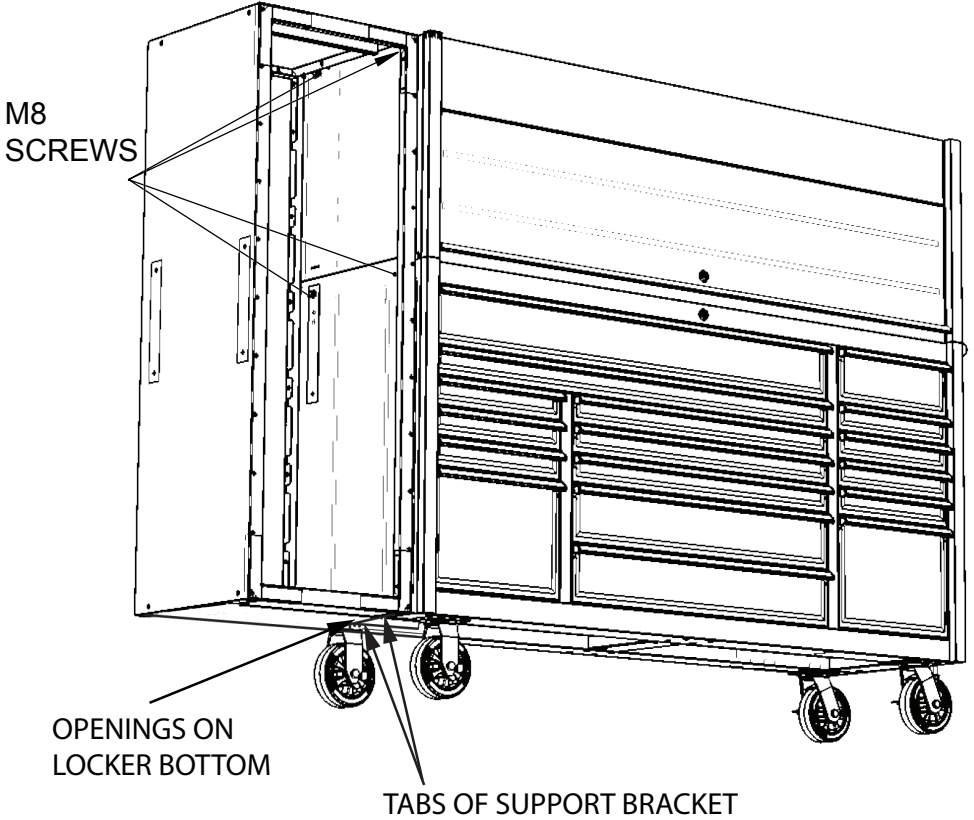

Step 11:

Install shelves in the desired positions by inserting the rear edge of each shelf into the slots of the back panel. While holding the front end of the shelf, insert the shelf clips into the slots on the side panels that are the same height as the back slots. Rest shelf on shelf clips.

With the help of another adult, install the side locker door using (6) M4 flat head screws.

Attach side locker door to side locker body using M4 flat head screws.

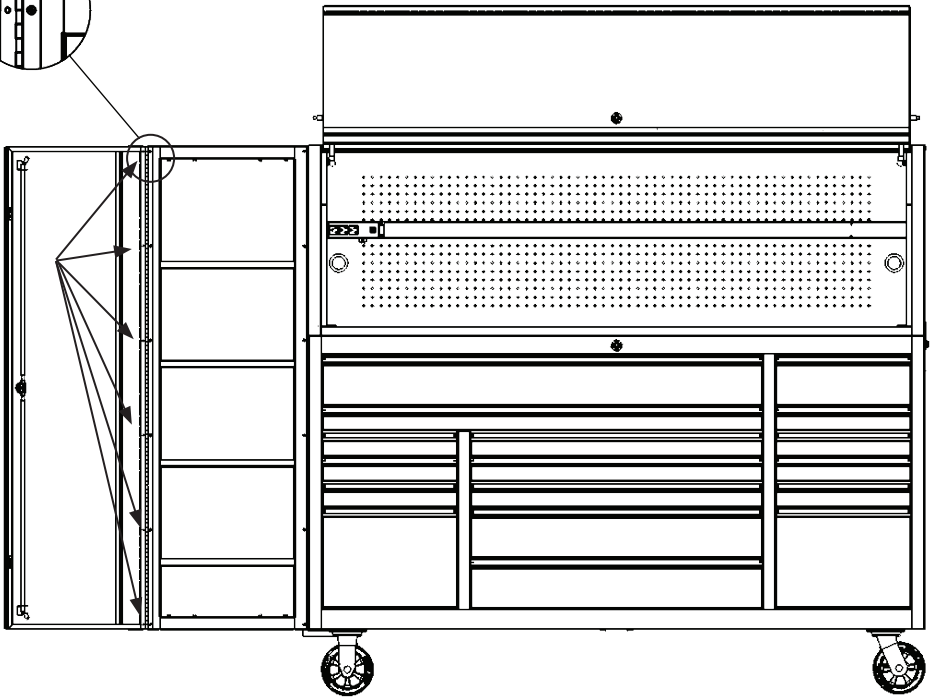

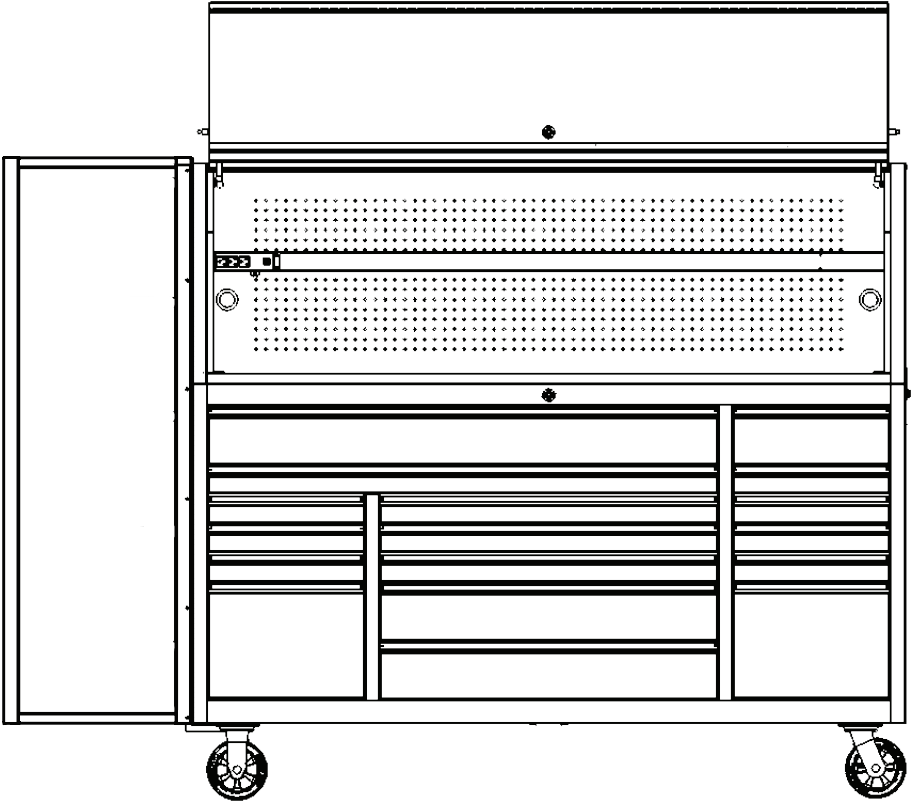

**DX192100SL DX Series 19"W x 21"D Side Locker
with 4 Adjustable Shelves**

*shown on DX722117RC 72"W x 21"D 17 Drawer Roller Cabinet &
DX722101HC 72"W x 21"D Extreme Power Workstation @ Hutch*