

# Assembly Instructions

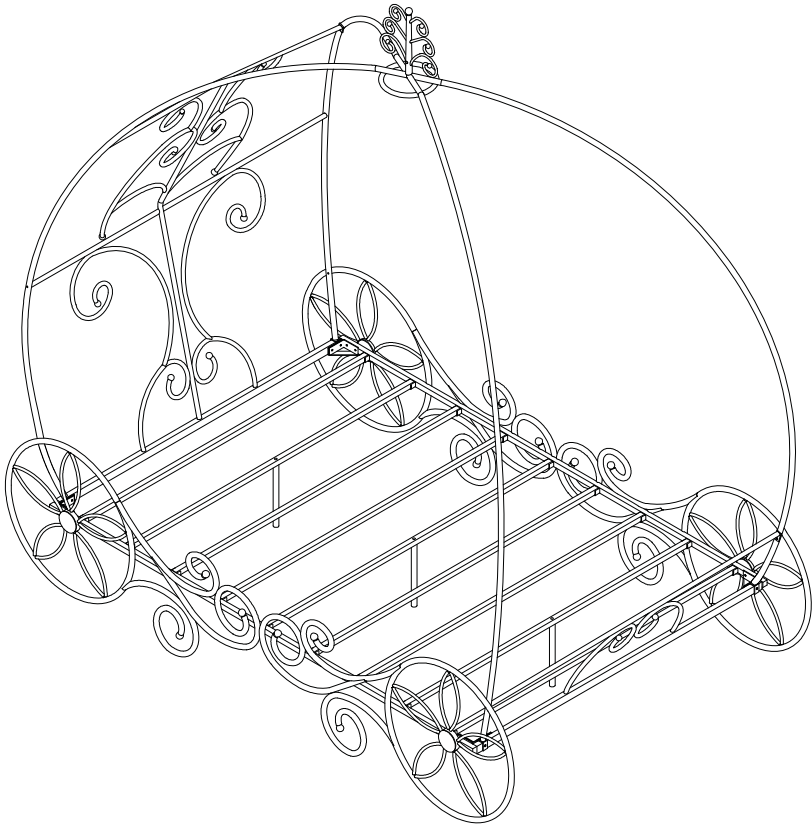

## ASSEMBLY RATING

The Assembly Rating is a 5-point system that shows the degree of effort needed in assembling a specific product (with 1 being easy and 5 being difficult). For some products, two persons are recommended.

## Tools Required For Assembly:

Allen Wrench

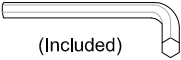

EASY



DIFFICULT

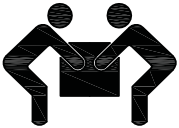

2 PERSONS RECOMMENDED

# ASSEMBLY & CARE ADVICE

FOR YOUR FURNITURE TO LAST, CORRECT ASSEMBLY AND PROPER MAINTENANCE ARE NECESSARY. PLEASE FOLLOW THE INFORMATION PROVIDED BELOW TO FULLY ENJOY YOUR FURNITURE.

## BASIC ASSEMBLY TECHNIQUES

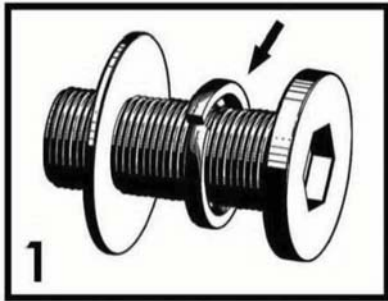

1 When lock or spring washer is used in an assembly, please make sure the lock or spring washer is placed between the larger flat washer and the head of the screw or bolt.



2 Position each part correctly and insert screws or bolts into their respective holes by hand tighten or using the proper hand tool. Only tighten when step is completed or when instructed to do so.



3 Use cardboard or carpet area when assembling furniture to prevent scratches. Make sure the furniture rests on a flat and level surface with each leg evenly touching the floor.

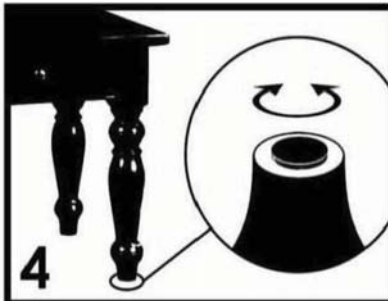

4 Some furniture comes with height adjustment knobs underneath each leg. To lower or to raise each leg, you need to turn clockwise or counterclockwise, respectively.



5 Make sure all parts are properly aligned, then use the appropriate hand tool to completely tighten the bolts or screws. Do not use power tools and do not overtighten.

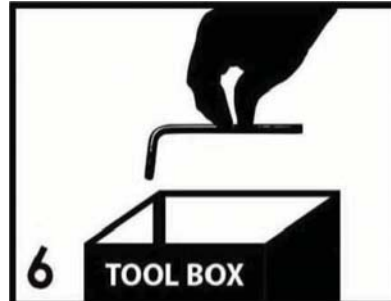

6 Save the instructions and store the Allen wrench or any supplied tool for later maintenance. After two weeks, check and tighten any loose hardware and repeat again every six months thereafter.

IT IS THE USER'S RESPONSIBILITY TO MAINTAIN THE FURNITURE. THE HARDWARE MAY LOOSEN OVER TIME AND MAY CAUSE THE FURNITURE TO BE WOBBLY AND UNABLE TO SUPPORT ITS INTENDED WEIGHT CAPACITY. THIS MAY LEAD TO COLLAPSE AND MAY CAUSE SERIOUS INJURY.

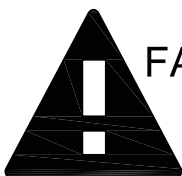

FAILURE TO FOLLOW THE GUIDELINES ABOVE MAY RESULT IN INJURY AND/OR PROPERTY DAMAGE.



Before you begin, please read Page 2 of "Assembly and Care Advice".

And remember, do not tighten until each step is completed or instructed.

### Parts List

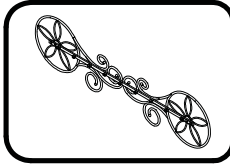
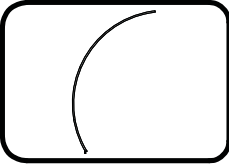
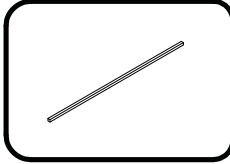
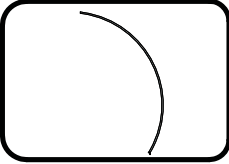
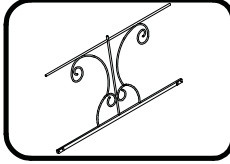
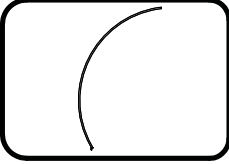
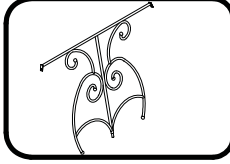
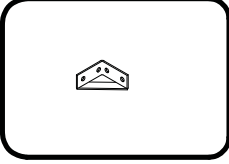
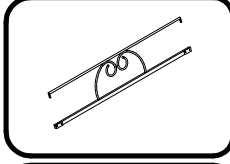
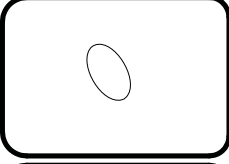
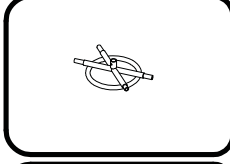
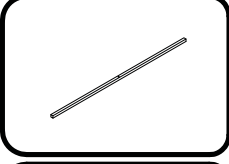
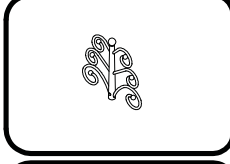
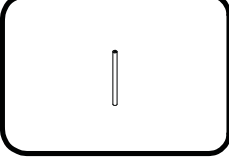
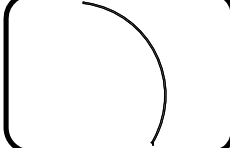
	#1 x 2pcs Side Guardrail		#9 x 1pc Headboard Support Bar ( R )
	#2 x 6pcs Slat A		#10 x 1pc Footboard Support Bar ( R )
	#3 x 1pc Headboard Frame (Down)		#11 x 1pc Footboard Support Bar ( L )
	#4 x 1pc Headboard Frame ( UP )		#12 x 4pcs Angle iron
	#5 x 1pc Footboard Frame		#13 x 4pcs Wheel Cover
	#6 x 1pc Top Crown Support		#14 x 3pcs Slat B
	#7 x 1pc Top Crown		#15 x 3pcs Slat Support Leg
	#8 x 1pc Headboard Support Bar ( L )		



Before you begin, please read Page 2 of "Assembly and Care Advice".

And remember, do not tighten until each step is completed or instructed.

### Hardware List



#A x 33pcs  
Bolt 1/4" X5/8"



#B x 9pcs  
Bolt 1/4" X1-3/16"



#C x 1pc  
Allen Wrench M4



#D x 6pcs  
Flat Washer



#1

1. Align the angle irons (#12) to the corners connecting the headboard frame down (#3), side guardrails (#1), and footboard frame (#5). Then insert 4 bolts (#A) into each angle iron and secure using the Allen wrench (#C).

#A x16pcs

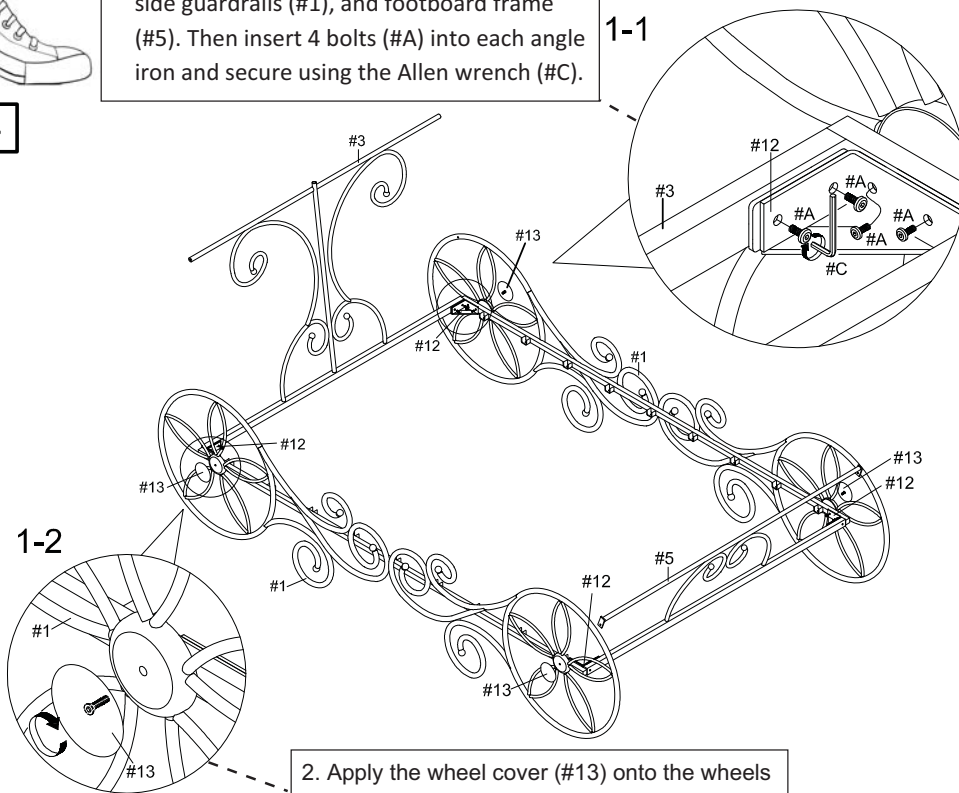

2. Apply the wheel cover (#13) onto the wheels by inserting the threaded end into the center hole. Turn clockwise (right) to tighten.



#2

#A x 4pcs  
#B x 6pcs

3. Insert bolts (#B) into the holes along the sides of the bars (#8,9). Secure using the Allen wrench.

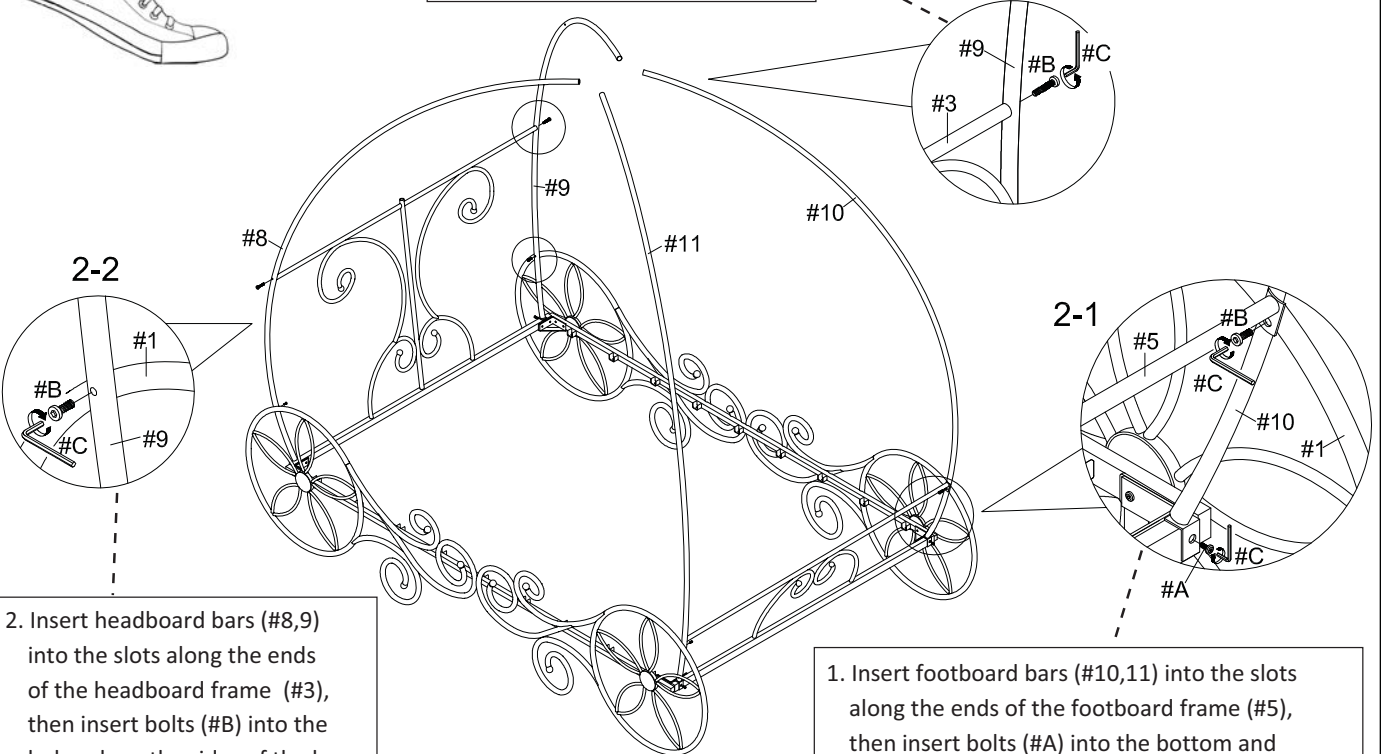

2. Insert headboard bars (#8,9) into the slots along the ends of the headboard frame (#3), then insert bolts (#B) into the holes along the sides of the bars (#8,9) to connect with the wheel. Secure using the Allen wrench.

1. Insert footboard bars (#10,11) into the slots along the ends of the footboard frame (#5), then insert bolts (#A) into the bottom and bolts (#B) into the holes along the sides of the bars (#10,11). Secure using the Allen wrench.



#A x 8pcs  
#D x 6pcs

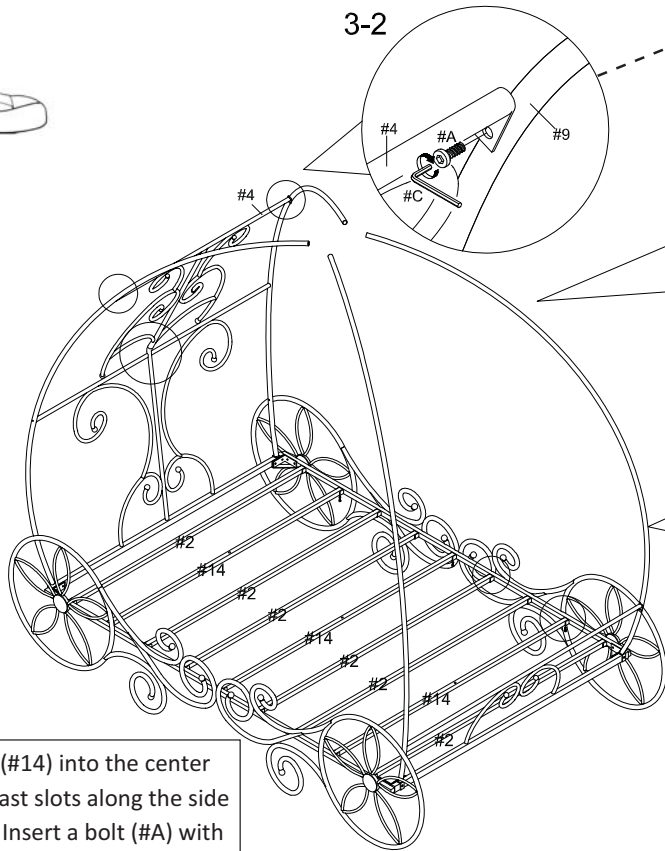

2. Align the ends of the headboard frame up (#4) to the holes along the headboard support bars (#8,9). Insert a bolt (#A) into each end. Secure using the Allen wrench.

3-1  
1. Insert the headboard frame up (#4) into the slot at the top of the headboard frame down (#3).

3-3  
3. Apply the slats (#2) into the slots along the side guardrails (#1).

4. Apply the slats (#14) into the center and second to last slots along the side guardrails (#1). Insert a bolt (#A) with flat washer (#D) into each end. Secure using the Allen wrench (#C).



#A x 5pcs

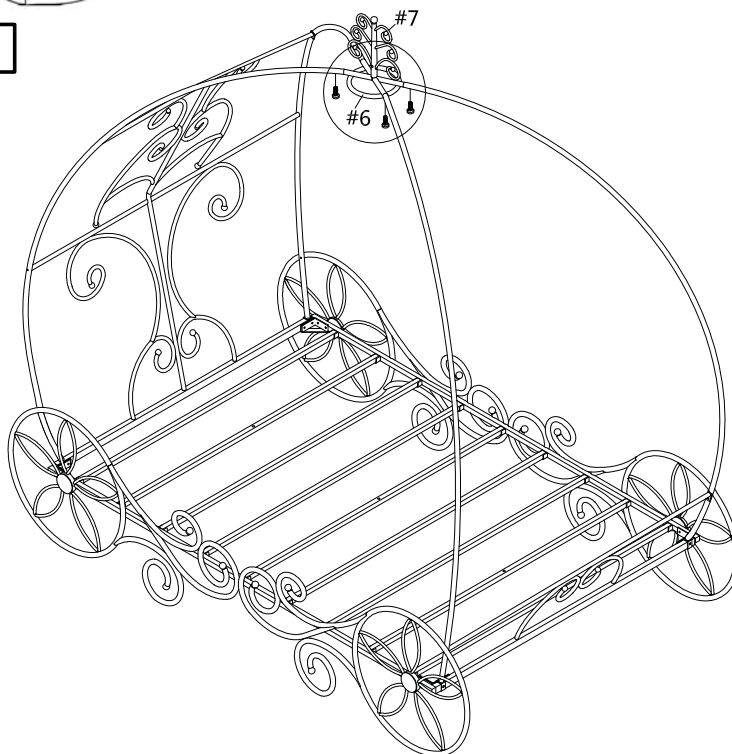

1. Insert the top crown (#7) into the top crown support (#6).

2. Insert a bolt (#A) and secure using the Allen wrench.

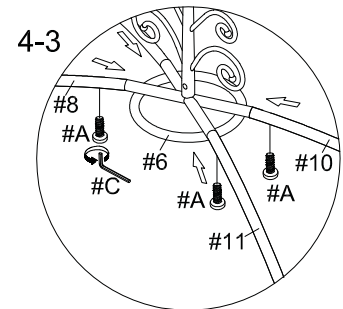
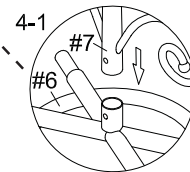
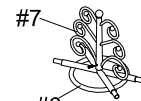

3. Insert the top of the support bars (#8,9,10,11) into the holes along the top crown support (#6), then insert a bolt (#A) into each hole. Secure using the Allen wrench.



#5

#B x 3pcs

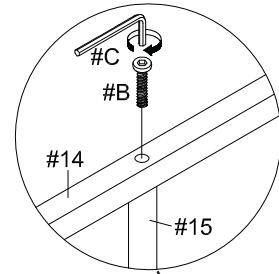
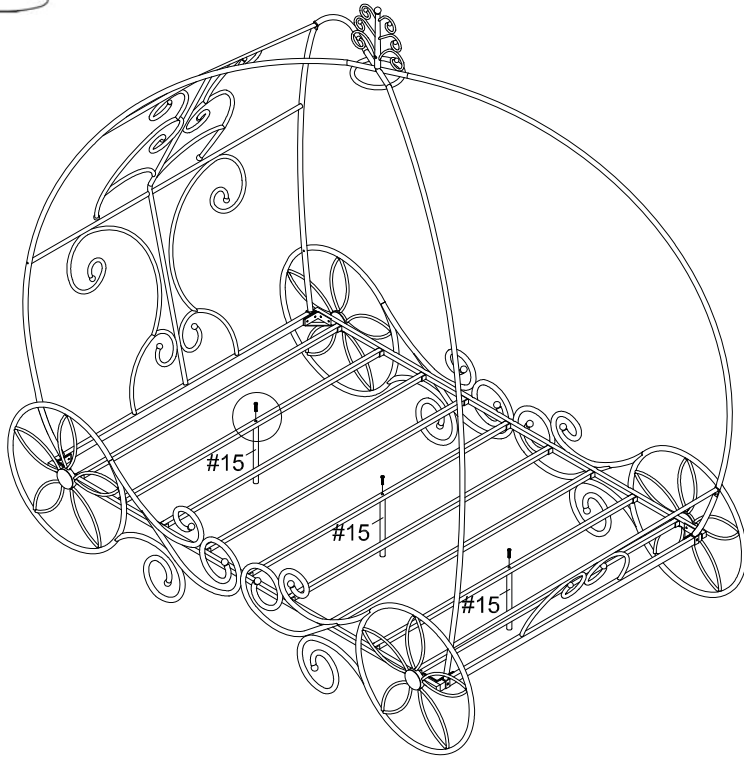

Align the slat support legs (#15) to the holes along the slats (#14), then insert a bolt (#B) into each slat from above and secure using the Allen wrench (#C).



#6

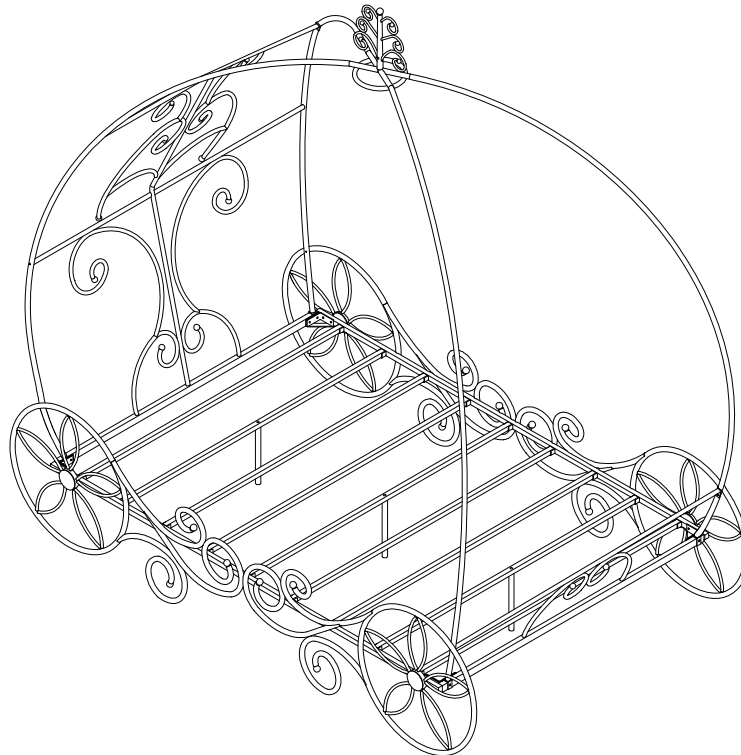

ASSEMBLY IS COMPLETED