

**CARE AND MAINTENANCE**

Always use felt pads under all articles to prevent discoloration or softening of the lacquer. Plastic and rubber bases on items can discolor wood. Wipe up spills immediately and avoid common hazards such as hot dishes, harsh solvents and abrasives. Cleaning should be done with a soft lint free cotton cloth dampened with water or furniture polish. On highly used surfaces we recommend applying a quality paste wax which should be used on a regular basis to provide additional protection from scratches and spills. How often you apply the wax depends on how much wear the furniture receives.

**NOTICE**

- \* Please make sure that you have all parts indicated before you begin assembly of this item
- \* This item should be assembled on a soft surface to prevent scratching the finish during assembly
- \* This item may require periodic tightening



**Part List and Hardware List**

Model#VNN1019A

Product Dimensions:L47.24xW15.75xH29.92 inches

PIECE	DESCRIPTION	PICTURE	QUANTITY
A	CEMENT TOP		1X
B	WOODEN LEGS		2X
C	WOODEN BAR		1X
D	WOODEN ARM		2X
H1	BOLT M8x50		4x
H2	BOLT M8x40		7x
H3	WASHER		11X
H4	ALLEN KEY		1X



**PREPARATION**

Before beginning assembly of product, make sure all parts are present. Compare parts with package contents list and hardware contents list.

If any part is missing or damaged, do not attempt to assemble the product.  
Estimated Assembly Time: 10 minutes.

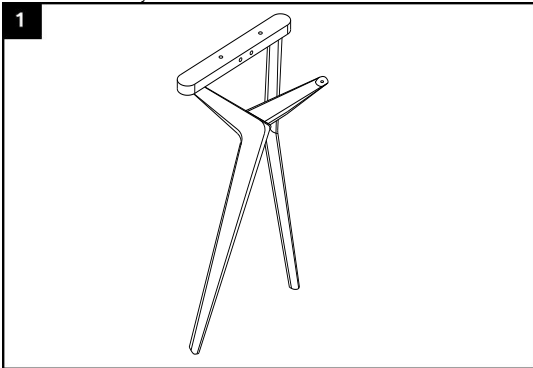

Step 1 : Fix (B) and (D) by wooden dowel

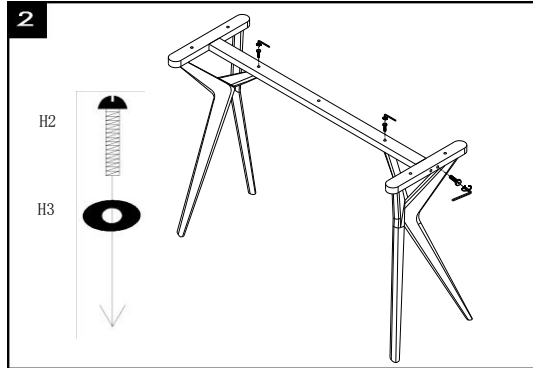

**Step 2** : the hardware needed to connect wooden legs and support bar ( C ) are bolts M8x50 ( H1 ) , washer ( H3). Fix ( D ) and ( C ) by bolt M8x40 ( H2)

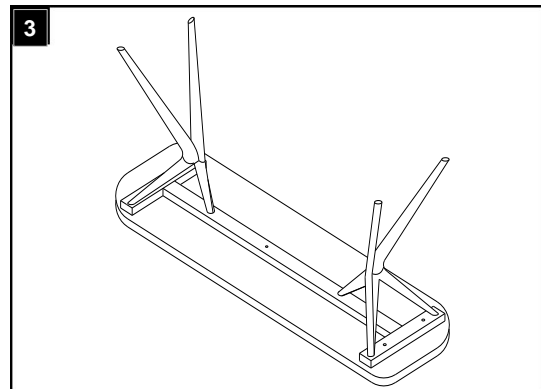

Step 3 : Connect concrete top ( A ) and wooden frame by 5 bolts M8x40 ( H2 ) and washer ( H3)

