

Save This Manual for Future Reference



Gasoline Engine

Operator's Manual

MODEL NUMBER
TR79

SERIAL NUMBER

PURCHASE DATE

Both model number and serial number may be found on the main label. You should record both of them in a safe place for future use.

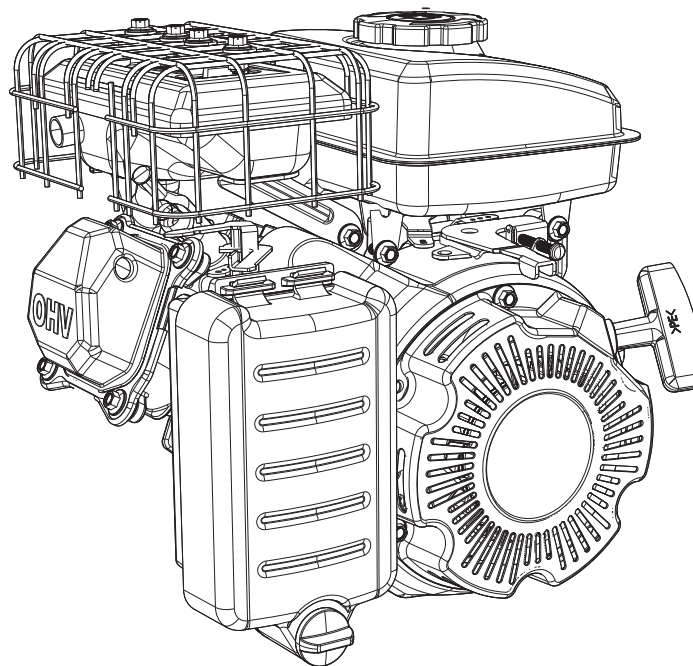

FOR YOUR SAFETY

READ AND UNDERSTAND THE ENTIRE MANUAL BEFORE OPERATING MACHINE

Tame the Great Outdoors®



Your new YARDMAX® engine offers quality construction that is easy and safe to operate. With proper use and care, it is designed to give you many years of dependable service.

Prepare to experience the durability to take on any job with the ease, portability, and convenience of your new engine!

Discover the YARDMAX Advantage

At YARDMAX, we understand that land ownership definitely has its privileges, but it also comes with a great deal of responsibility. When duty calls and you need to respond, will you have what it takes to tame the great outdoors?

When looking for outdoor power equipment (OPE) to get the job done right, at the right price, YARDMAX delivers the perfect combination of performance and practicality. YARDMAX has a solution that's right for you.

MAX Performance, MAX Value, MAX Support – that's YARDMAX

- ✓ Backed by decades of proven manufacturing expertise
- ✓ Enhanced design features come standard
- ✓ Engineered for the best user experience
- ✓ Quality metal parts are used instead of plastic
- ✓ A robust warranty supports all products
- ✓ Budget-friendly prices make it practical



Up for the job? YARDMAX is.

TABLE OF CONTENTS

Introduction	1	Operation	8
Specifications	3	Maintenance	10
Safety	4	Storage	15
Know Your Engine	5	Troubleshooting	17
Controls	6	Technical & Consumer Information	18
Check before Operation	7	Wiring Diagram	19

DISCLAIMER

Keep this owner's manual handy, so you can refer to it at any time.

This owner's manual is considered a permanent part of the engine and should remain with the engine if resold.

The information and specifications included in this publication were in effect at the time of approval for printing.

READ THIS OWNER'S MANUAL CAREFULLY. Pay special attention to these symbols and any instructions that follow:

⚠ WARNING *Indicates serious injury or death will result if instructions are not followed.*

⚠ DANGER *Indicates a strong possibility that serious injury or death could result if instructions are not followed.*

⚠ CAUTION *Indicates a possibility that minor injury or an result if instructions are not followed.*

📌 NOTE *Indicates that equipment or property damage can result if instructions are not followed.*

If a problem should arise, or if you have any questions about your engine, consult your engine dealer.

⚠ WARNING *Carefully read through this entire operator's manual before using your new engine. Pay attention to all cautions and warnings.*

ENVIRONMENTAL

Recycle unwanted materials instead of disposing of them as waste. All tools, hoses, and packaging should be resorted, taken to the local recycling center and disposed of in an environmentally safe way.

ENGINE SERIAL NUMBER

Record the engine serial number on the front cover of this manual. You will need this serial number when ordering parts, and when making technical or warranty inquiries.

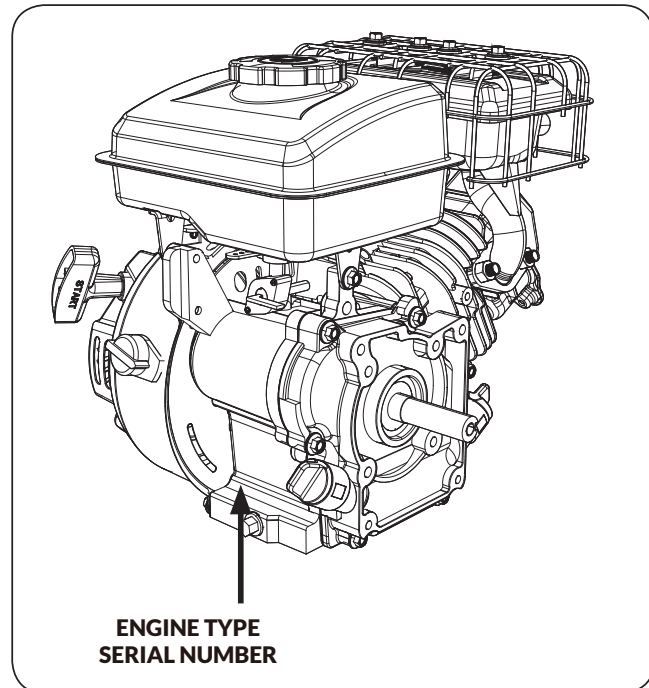
**DISCLAIMER**

YARDMAX reserves the right to discontinue, change, and improve its products at any time without notice or obligation to the purchaser. The descriptions and specifications contained in this manual were in effect at printing. Equipment described within this manual may be optional. Some illustrations may not be applicable to your unit.

SUPPORT

Have questions about your YARDMAX equipment? Call us at 844-927-3629 or 844-YARDMAX, email us at support@yardmax.com, or contact us via your favorite social media site.

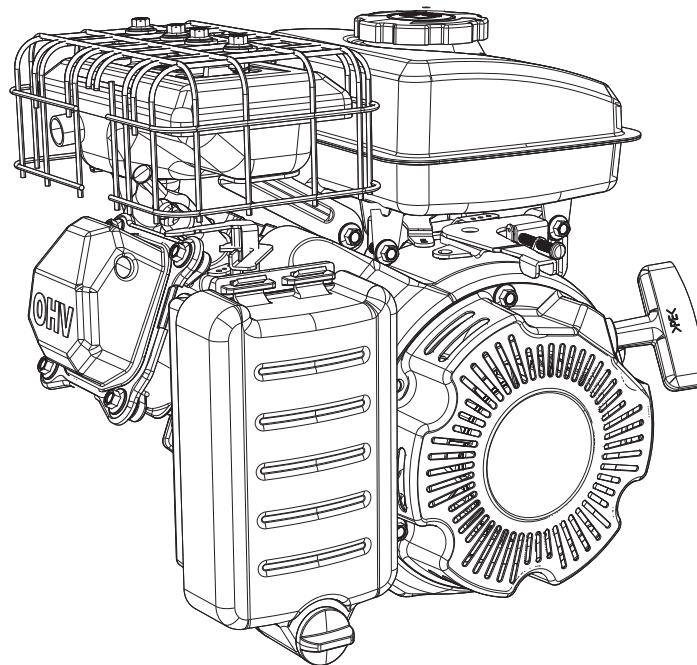

SPECIFICATIONS

Model	TR79
Type	Single cylinder 4-Stroke Forced air cooling
Rated power (kW/3600rpm)*	1.5Kw/3600rpm
Max torque N•m/rpm	3.9N.m/3000rpm
Fuel consumption ratio (g/kW•h)	≤450
Idle speed (rpm)	1800±200
Speed fluctuating ratio	≤10%
Noise ≤ dB(A)	65
Bore×Stroke (mm)	52X37
Displacement (cc)	79
Compression ratio	8.5:1
Lubricating mode	Splash

Starting mode	Recoil start	
Rotation	Anti-clockwise (from P.T.O.Side)	
Valve clearance (mm)	Intake valve 0.15±0.02 (cold) Exhaust valve 0.20±0.02 (cold)	
Spark plug gap (mm)	0.7~0.8	
Ignition mode	Transistorized magneto ignition	
Air cleaner	Semi-dry, Oil bath, Foam filter	
Dimension (inch)	Length	12.8
	Width	12.4
	Height	12.6
Net weight (lbs)	21	

* The power rating of the engine indicated in this document is the net power output tested on a production engine for the engine model and measured in accordance with SAE J1349 at 3,600 rpm (Net Power) and at 3,800 rpm (Max. Net Torque). Mass production engines may vary from this value.

* Actual power output for the engine installed in the final machine will vary depending on numerous factors, including the operating speed of the engine in application, environmental conditions, maintenance, and other variables.

SAFETY

IMPORTANT SAFETY INFORMATION

Most accidents with engines can be prevented if you follow all instructions in this manual and on the engine. Some of the most common hazards are discussed below, along with the best way to protect yourself and others.

OWNER RESPONSIBILITIES

- YARDMAX engines are designed to give safe and dependable service if operated according to instructions. Read and understand this owner's manual before operating the engine. Failure to do so could result in personal injury or equipment damage.
- Know how to stop the engine quickly, and understand the operation of all controls. Never permit anyone to operate the engine without proper instructions.
- Do not allow children to operate the engine. Keep children and pets far away from the area of operation.

OPERATOR SAFETY

Safety Measures

! WARNING Wash hands after using the machine, refueling, and changing fluids. Certain components in this product and its accessories contain chemicals known to cause cancer, birth defects, or other reproductive harm according to the State of California.

! WARNING Always run your engine outdoors. Exhaust from the engine contains fumes known to cause cancer, birth defects, or other reproductive harm according to the State of California.

! WARNING YARDMAX engines are not engineered or intended to be used to power any other device than what it was originally specified in. Including but not limited to competitive racing events, recreational, sport or all-terrain vehicles (ATV's), go-karts, fun-karts, golf-carts, etc.

START/STOP SAFETY

Starting The Engine

! WARNING Kick back or rapid retraction of the recoil cord will pull the operators hand and arm towards the engine quicker than you can let go.

Avoiding Kick Back

- Lightly pull the recoil handle so that the cord is taught prior to pulling harder to start.
- Grip the starter handle so you can quickly release it if needed. If gripped too tightly injury could result.
- When the rope is taut with resistance pull quickly and smoothly to avoid kick back.

FUEL SAFETY

! WARNING Fuel and its vapors are extremely flammable and explosive. Fire or explosion can cause severe burns or death. Keep fuel away from sparks, open flames, pilot lights, heat sources, or any other ignition sources. If fuel spills, wait for it to completely evaporate before starting the engine.

HOT EXHAUST

- The muffler will become very hot during operation and will remain hot for a while after stopping the engine. Be careful not to touch the muffler while it is hot. Let the engine cool before storing it indoors.
- To prevent fire hazards and to provide adequate ventilation for stationary equipment applications, keep the engine at least 3 feet (1 meter) away from both building walls and from other equipment during operation. Do not place flammable objects close to the engine.

CARBON MONOXIDE HAZARD

Exhaust gas contains poisonous carbon monoxide. Avoid inhalation of exhaust gas. Never run the engine in a closed garage or confined area.

OTHER EQUIPMENT

Review the instructions provided with the equipment powered by this engine for any additional safety precautions that should be observed in conjunction with engine startup, shutdown, operation, or protective apparel that may be needed to operate the equipment.

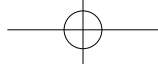

KNOW YOUR ENGINE

FEATURES AND CONTROLS

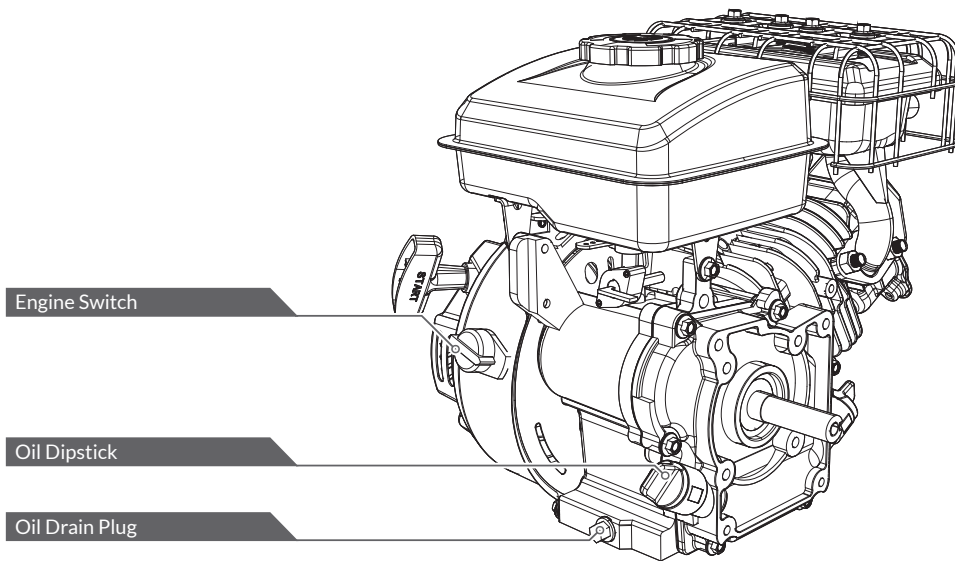
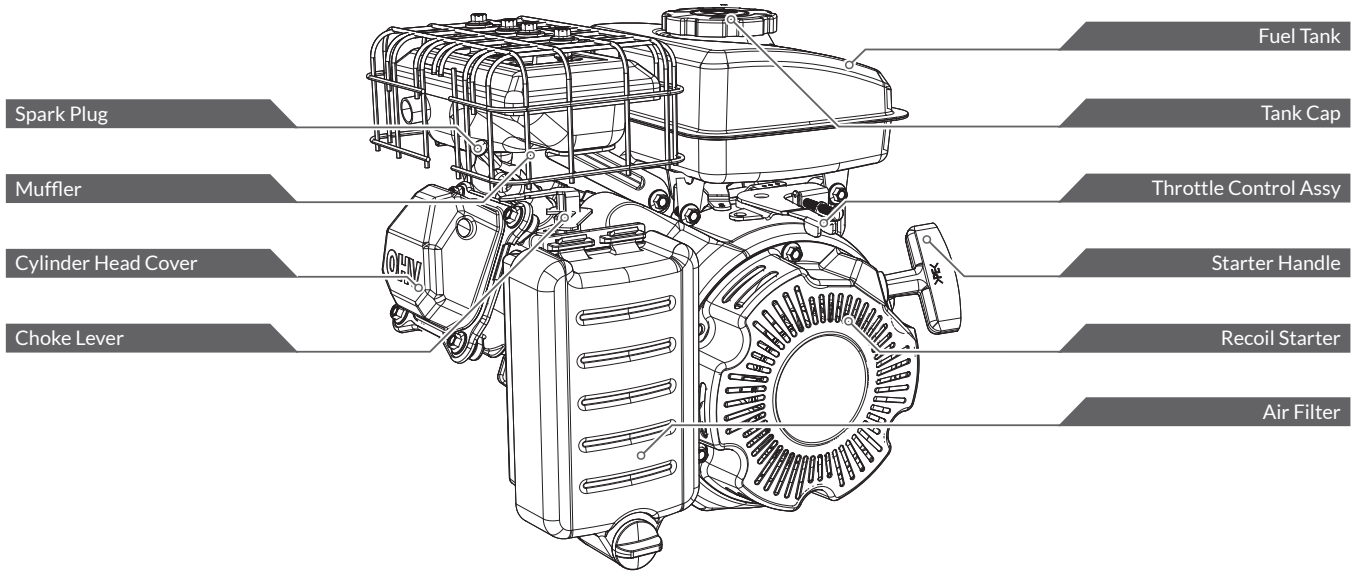

CONTROLS

FUEL VALVE LEVER

The fuel valve opens and closes the passage between the fuel tank and the carburetor. The fuel valve lever must be in the ON position for the engine to run.

When the engine is not in use, leave the fuel valve lever in the OFF position to prevent carburetor flooding and to reduce the possibility of fuel leakage.

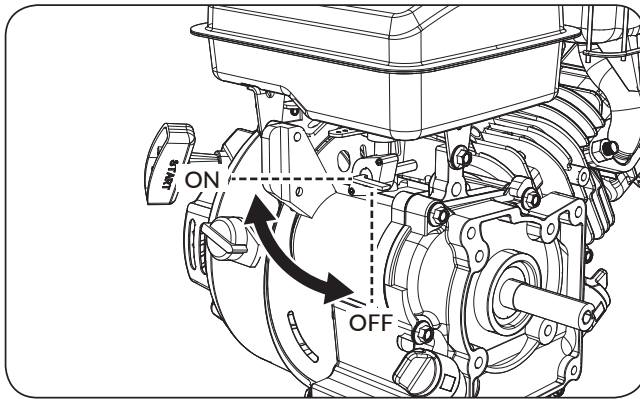

Figure 1

THROTTLE LEVER

The throttle lever controls engine THROTTLE LEVER speed.

Moving the throttle lever in the directions shown makes the engine run faster or slower.

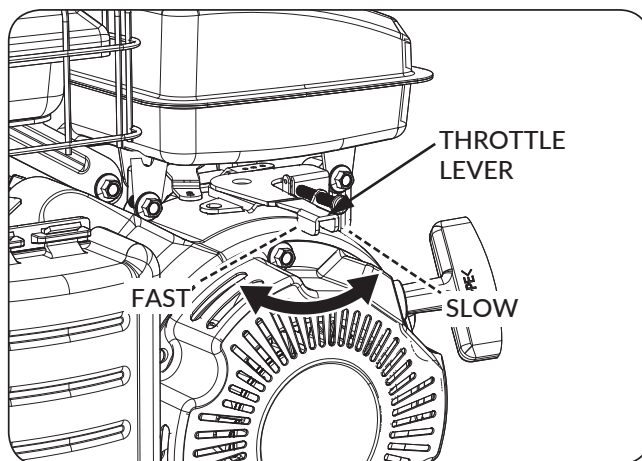

Figure 2

ENGINE SWITCH

The engine switch enables and disables the ignition system.

The engine switch must be in the ON position for the engine to run.

Turning the engine switch to the OFF position stops the engine.

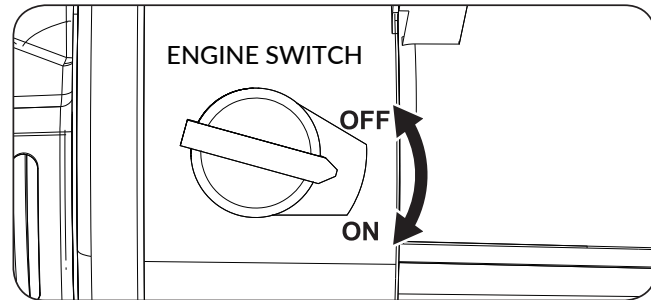

Figure 3

CHOKE LEVER

The choke lever opens and closes the choke valve in the carburetor.

The CLOSE position enriches the fuel mixture for starting a cold engine.

The OPEN position provides the correct fuel mixture for operation after starting, and for restarting a warm engine.

Some engine applications use a remotely-mounted choke control rather than the engine-mounted choke lever shown here.

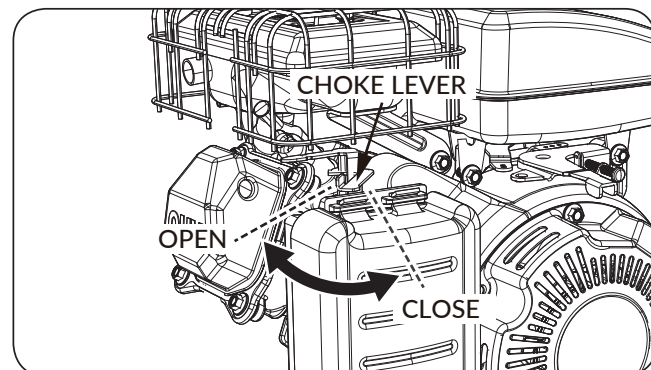

Figure 4

RECOIL STARTER GRIP

Pulling the starter grip operates the recoil starter to crank the engine.

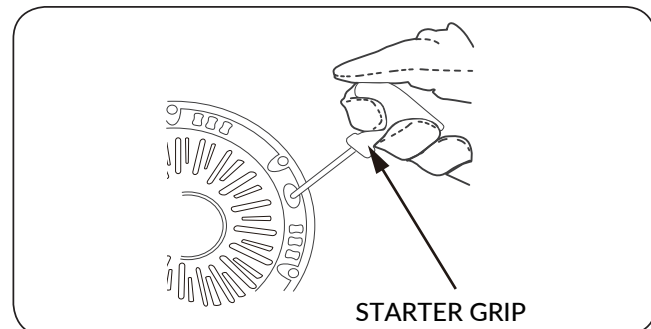

Figure 5



CHECK BEFORE OPERATION

IS YOUR ENGINE READY TO GO?

For your safety, and to maximize the service life of your equipment, it is very important to take a few moments before you operate the engine to check its condition. Be sure to take care of any problem you find, or have your servicing dealer correct it, before you operate the engine.

⚠ WARNING *Improperly maintaining this engine, or failing to correct a problem before operation, could cause a malfunction in which you could be seriously injured.*
Always perform a preoperation inspection before each operation, and correct any problem.

Before beginning your preoperation checks, be sure the engine is level and the engine key has been removed.

CHECK THE GENERAL CONDITION OF THE ENGINE

- Look around and underneath the engine for signs of oil or gasoline leaks.
- Remove any excessive dirt or debris, especially around the muffler and recoil starter.
- Look for signs of damage.
- Check that all shields and covers are in place, and all nuts, bolts, and screws are tightened.

CHECK THE ENGINE

Check the engine oil level. Running the engine with a low oil level can cause engine damage.

The Oil Alert system (applicable engine types:TR79/TR196/TR389) will automatically stop the engine before the oil level falls below safe limits. However, to avoid the inconvenience of an unexpected shutdown, always check the engine oil level before startup.

Check the air filter. A dirty air filter will restrict air flow to the carburetor, reducing engine performance.

Check the fuel level. Starting with a full tank will help to eliminate or reduce operating interruptions for refueling.

CHECK THE EQUIPMENT POWERED BY THIS ENGINE

Review the instructions provided with the equipment powered by this engine for any precautions and procedures that should be followed before engine startup.

OPERATION

SAFE OPERATING PRECAUTIONS

Before operating the engine for the first time, please review the **IMPORTANT SAFETY**

INFORMATION and the chapter titled **BEFORE OPERATION**.

! WARNING Carbon monoxide gas is toxic. Breathing it can cause unconsciousness and even kill you. Avoid any areas or actions that expose you to carbon monoxide.

Review the instructions provided with the equipment powered by this engine for any safety precautions that should be observed in conjunction with engine startup, shutdown, or operation.

STARTING THE ENGINE

1. Move the fuel valve lever to the ON position.

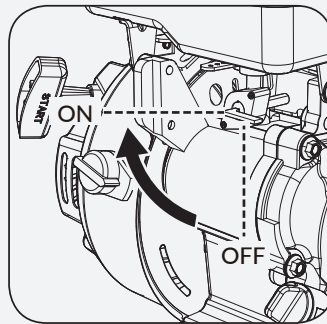

Figure 6

2. To start a cold engine, move the choke lever to the CLOSE position.

To restart a warm engine, leave the choke lever in the OPEN position.

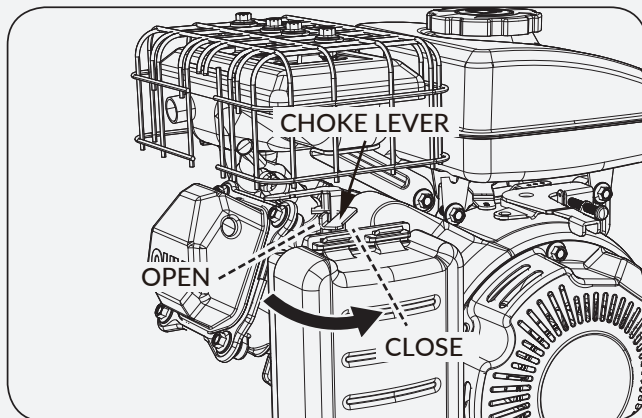

Figure 7

3. Move the throttle lever away from the SLOW position, about 1/3 of the way toward the FAST position.

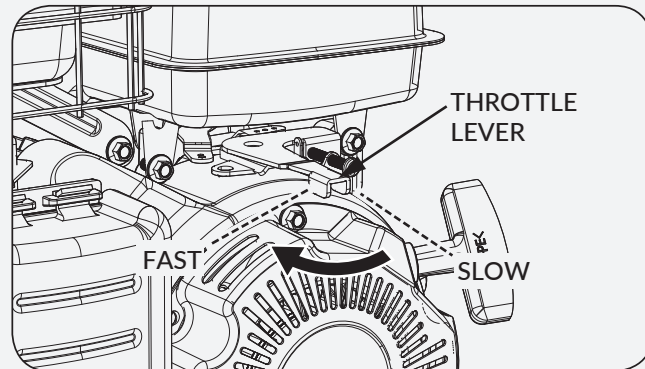

Figure 8

4. Turn the engine switch to the ON position.

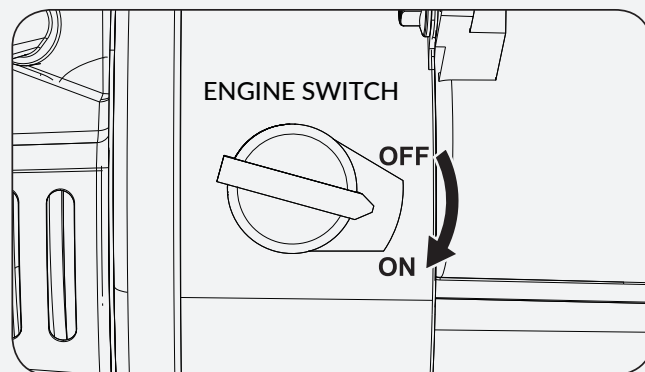

Figure 9

5. Operate the starter.

RECOIL STARTER:

Pull the starter grip lightly until you feel resistance, then pull briskly.

Return the starter grip gently.

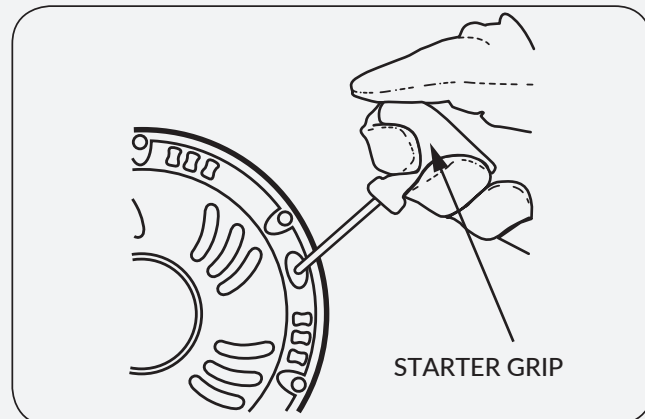

Figure 10

6. If the choke lever has been moved to the CLOSE position to start the engine, gradually move it to the OPEN position as the engine warms up.

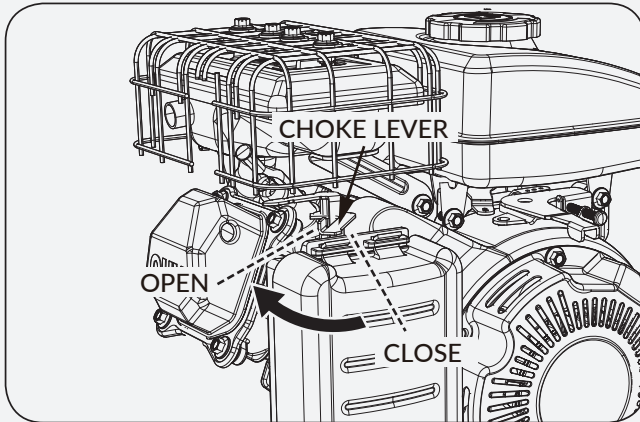

Figure 11

STOPPING THE ENGINE

To stop the engine in an emergency, simply turn the engine switch to the OFF position. Under normal conditions, use the following procedure.

1. Move the throttle lever to the SLOW position.

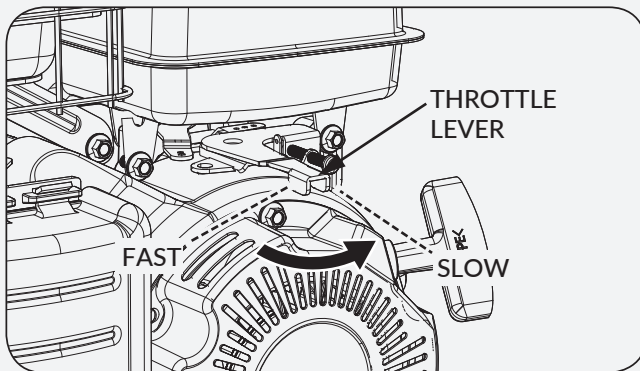

Figure 12

2. Turn the engine switch to the OFF position.

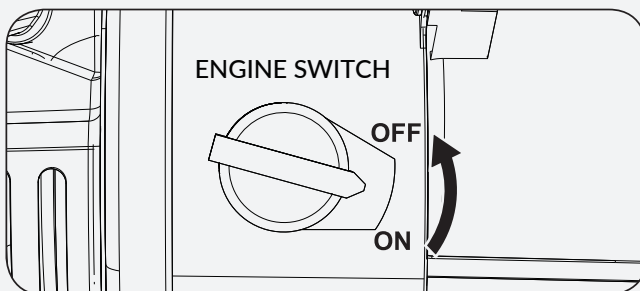

Figure 13

3. Turn the fuel valve lever to the OFF position.

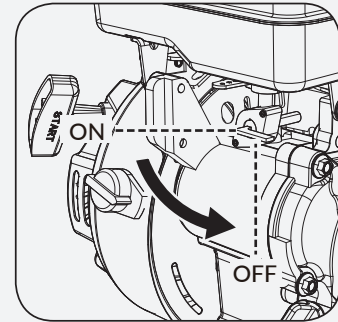

Figure 14

SETTING ENGINE SPEED

Position the throttle lever for the desired engine speed.

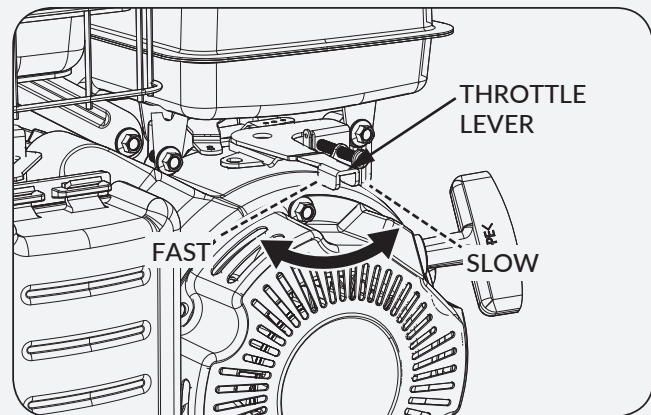

Figure 15

MAINTENANCE

MAINTENANCE SCHEDULE

REGULAR SERVICE PERIOD		Each use	First month or 20 Hrs.	Every 3 months or 50 Hrs.	Every 6 months or 100 Hrs.	Every year or 150 Hrs.
Engine oil	Check level	○				
	Change		○		○	
Air cleaner	Check	○				
	Clean			○(1)		
	Replace					○(2)
Sediment Cup	Clean				○	
Spark plug	Clean				○	Replace
Spark Arrester	Clean				○	
Idle Speed	Check-Adjust					○(2)
Valve clearance	Check-Adjust					○(2)
Fuel tank and fuel filter	Clean				○(2)	
Cover comp head	Clean	After every 300 Hrs. (2)				
Fuel line	Check	Every 2 years (Replace if necessary) (2)				

- Emission-related items.

- Replace the paper element type only.

(1) Service more frequently when used in dusty areas.

(2) These items should be serviced by your servicing dealer unless you have the proper tools and are mechanically proficient. Refer to manual for service procedures.

THE IMPORTANCE OF MAINTENANCE

We recommend you take your YARDMAX engine to a YARDMAX authorized service center to have all maintenance and service of the engine and its parts.

⚠ WARNING *Improperly maintaining this engine, or failure to correct a problem before operation, can cause a malfunction in which you can be seriously hurt or killed. Always follow the inspection and maintenance recommendations and schedules in this owner's manual.*

To help you properly care for your engine, the following pages include a maintenance schedule, routine inspection procedures, and simple maintenance procedures using basic hand tools. Other

service tasks that are more difficult, or require special tools, are best handled by professionals and are normally performed by a technician or other qualified mechanic.

The maintenance schedule applies to normal operating conditions. If you operate your engine under unusual conditions, such as sustained high-load or high-temperature operation, or use in unusually wet or dusty conditions, consult your servicing dealer for recommendations applicable to your individual needs and use.

MAINTENANCE SAFETY

Some of the most important safety precautions are as follows: However, we cannot warn you of every conceivable hazard that can arise in performing maintenance. Only you can decide whether or not you should perform a given task.

⚠ WARNING Failure to properly follow maintenance instructions and precautions can cause you to be seriously hurt or killed. Always follow the procedures and precautions in the owner's manual.

SAFETY PRECAUTIONS

- Make sure the engine is off before you begin any maintenance or repairs. This will eliminate several potential hazards:
 - Carbon monoxide poisoning from engine exhaust.
Be sure there is adequate ventilation whenever you operate the engine.
 - Burns from hot parts.
Let the engine and exhaust system cool before touching.
 - Injury from moving parts.
Do not run the engine unless instructed to do so.
- Read the instructions before you begin, and make sure you have the tools and skills required.
- To reduce the possibility of fire or explosion, be careful when working around gasoline. Use only a nonflammable solvent, not gasoline, to clean parts. Keep cigarettes, sparks and flames away from all fuel-related parts.

To ensure the best quality and reliability, use only new, genuine parts or their equivalents for repair and replacement.

REFUELING

Fuel tank capacities : 1.6 L

With the engine stopped, remove the fuel tank cap and check the fuel level. Refill the tank if the fuel level is low.

⚠ WARNING Gasoline is highly flammable and explosive. You can be burned or seriously injured when handling fuel.

- Stop the engine and keep heat, sparks, and flame away.
- Handle fuel only outdoors.
- Wipe up spills immediately.

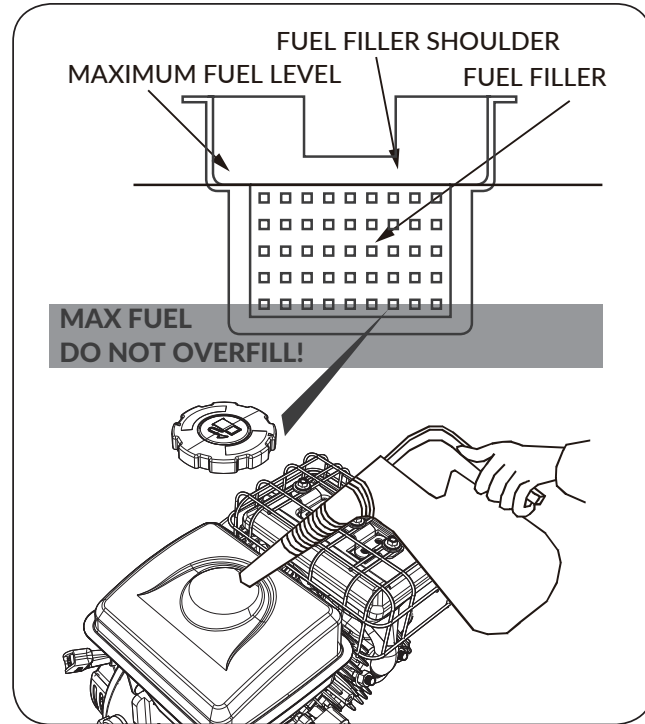

Figure 16

Refuel in a well-ventilated area before starting the engine. If the engine has been running, allow it to cool. Refuel carefully to avoid spilling fuel. Do not fill above the fuel strainer shoulder. After refueling, tighten the fuel tank cap securely.

Never refuel the engine inside a building where gasoline fumes may reach flames or sparks. Keep gasoline away from appliance pilot lights, barbecues, electric appliances, power tools, etc.

Spilled fuel is not only a fire hazard, it causes environmental damage. Wipe up spills immediately.

🏷 NOTE Fuel can damage paint and plastic. Be careful not to spill fuel when filling your fuel tank. Damage caused by spilled fuel is not covered under warranty.

FUEL RECOMMENDATIONS

Use unleaded gasoline with a pump octane rating of 86 or higher.

These engines are certified to operate on unleaded gasoline. Unleaded gasoline produces fewer engine and spark plug deposits and extends exhaust system life.

Never use stale or contaminated gasoline or an oil/gasoline mixture. Avoid getting dirt or water in the fuel tank.

Occasionally you may hear a light “spark knock” or “pinging” (metallic rapping noise) while operating under heavy loads. This is no cause for concern.

If spark knock or pinging occurs at a steady engine speed, under

normal load, change brands of gasoline. If spark knock or pinging persists, see an authorized servicing dealer.

**NOTE**

Running the engine with persistent spark knock or pinging can cause engine damage. Running the engine with persistent spark knock or pinging is considered misuse, and the Distributor's Limited Warranty does not cover parts damaged by misuse.

ENGINE OIL LEVEL CHECK

Check the engine oil level with the engine stopped and in a level position.

1. Remove the filler cap/dipstick and wipe it clean.

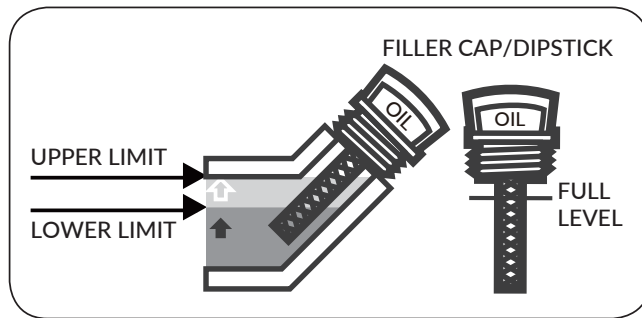
**Figure 17**

2. Insert and remove the dipstick without screwing it into the filler neck. Check the oil level shown on the dipstick.
3. If the oil level is low, fill to the edge of the oil filler hole with the recommended oil.
4. Screw in the filler cap/dipstick securely.

**NOTE**

Running the engine with a low oil level can cause engine damage.

The Oil Alert system will automatically stop the engine before the oil level falls below safe limit. However, to avoid the inconvenience of an unexpected shutdown, always check the engine oil level before startup.

ENGINE OIL CHANGE

Drain the used oil while the engine is warm. Warm oil drains quickly and completely.

1. Place a suitable container below the engine to catch the used oil, and then remove the filler cap/dipstick and the drain plug. Slant the engine with the angle of a certain degree to help drain more quickly and completely.
2. Allow the used oil to drain completely, and then reinstall the drain plug, and tighten it securely.

Please dispose of used motor oil in a manner that is compatible with the environment. We suggest you take used oil in a sealed container to your local recycling center or service station for reclamation. Do not throw it in the trash; pour it on the ground; or down a drain.

3. With the engine in a level position, fill to the outer edge of the oil filler hole with the recommended oil.

Engine oil capacities: 0.4L

Running the engine with a low oil level can cause engine damage.

The Oil Alert system (applicable engine types) will automatically stop the engine before the oil level falls below the safe limit.

However, to avoid the inconvenience of an unexpected shutdown, fill to the upper limit, and check the oil level regularly.

4. Screw in the filler cap/dipstick securely.

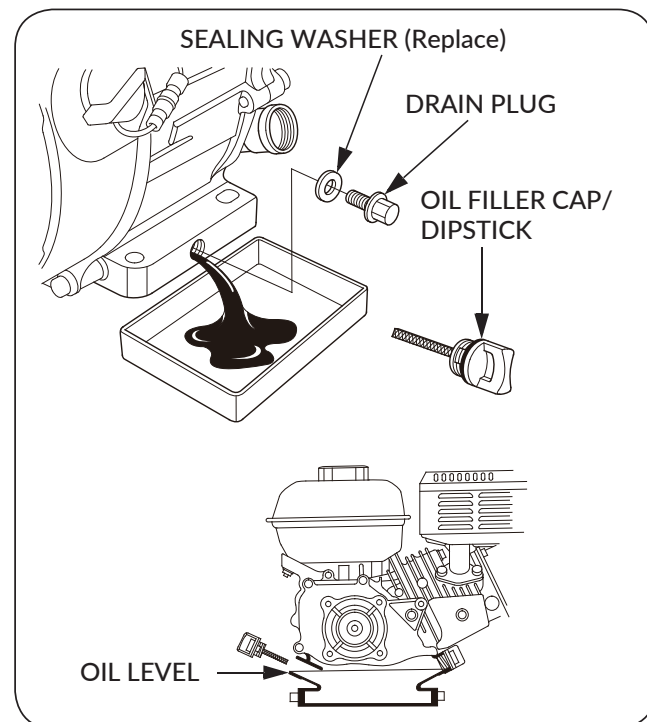
**Figure 18****ENGINE OIL RECOMMENDATIONS**

Oil is a major factor affecting performance and service life. Use 4-stroke automotive detergent oil.

SAE 10W-30 is recommended for general use. Other viscosities shown in the chart may be used when the average temperature in your area is within the recommended range.

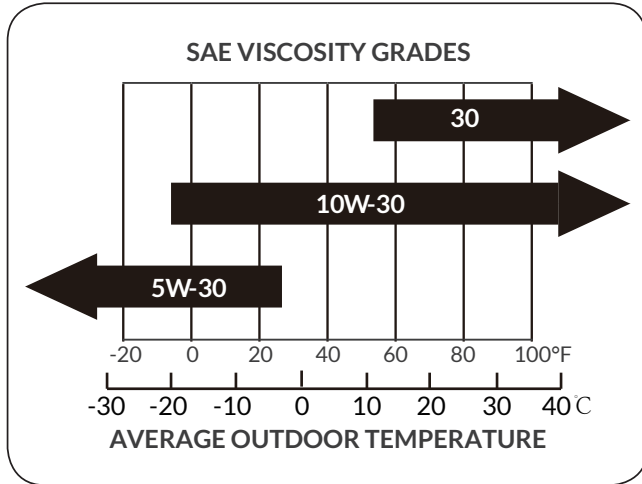

Figure 19

AMBIENT TEMPERATURE

The SAE oil viscosity and service classification are in the API label on the oil container.

We recommend that you use API SERVICE Category SE or SF oil.

AIR FILTER INSPECTION

Remove the air cleaner cover and inspect the filter. Clean or replace dirty filter elements.

Always replace damaged filter elements.

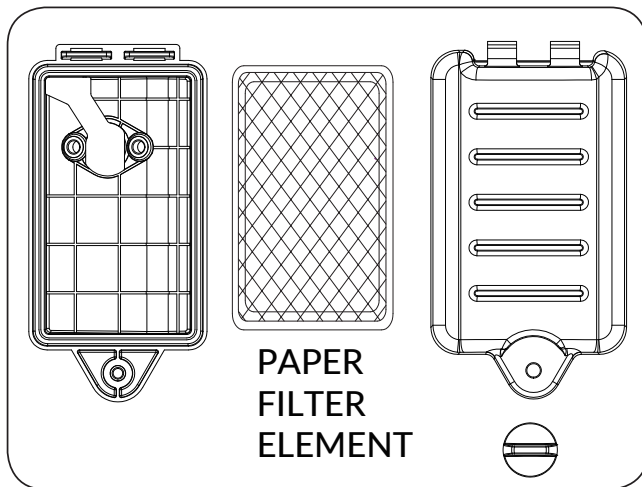

Figure 20

AIR CLEANER SERVICE

A dirty air filter will restrict air flow to the carburetor, reducing engine performance.

If you operate the engine in very dusty areas, clean the air filter more often than specified in the MAINTENANCE SCHEDULE.

NOTE

Operating the engine without an air filter, or with a damaged air filter, will allow dirt to enter the engine, causing rapid engine wear. This type of damage is not covered by the Distributor's Limited Warranty.

SEDIMENT CUP CLEANING

1. Move the fuel valve to the OFF position, and then remove the fuel sediment cup and O-ring.

WARNING

Gasoline is highly flammable and explosive.

You can be burned or seriously injured when handling fuel.

- Keep heat, sparks and flame away.
- Handle fuel only outdoors.
- Wipe up spills immediately.
- Start the engine more than 3 meters away from the place of refueling.

2. Wash the sediment cup and O-ring in nonflammable solvent, and dry them thoroughly.

3. Place the O-ring in the fuel valve, and install the sediment cup. Tighten the sediment cup securely.

4. Move the fuel valve to the ON position, and check for leaks. Replace the O-ring if there is any leakage.

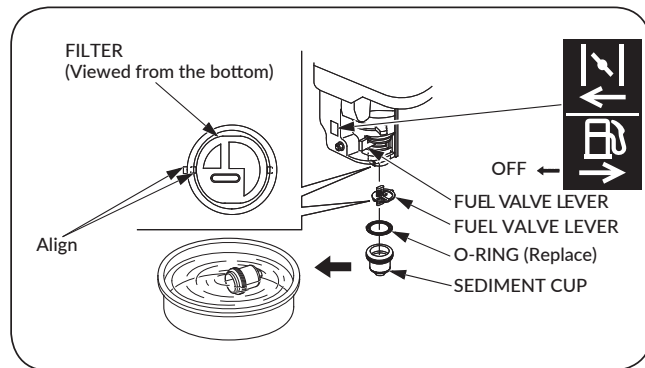

Figure 21

SPARK PLUG SERVICE

Recommended spark plugs: E6RTC/E6TC

NOTE

An incorrect spark plug can cause engine damage.

1. Disconnect the spark plug cap, and remove any dirt from around the spark plug area.

2. Remove the spark plug with a spark plug wrench.

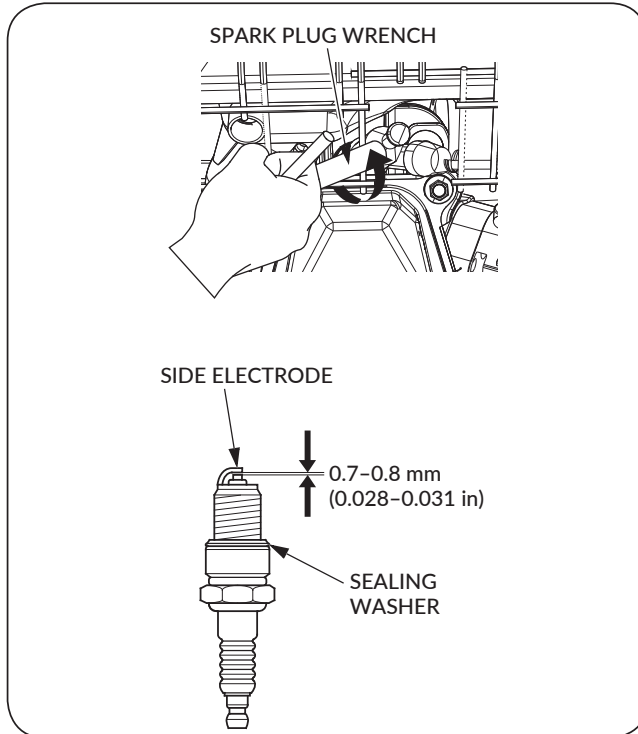

Figure 22

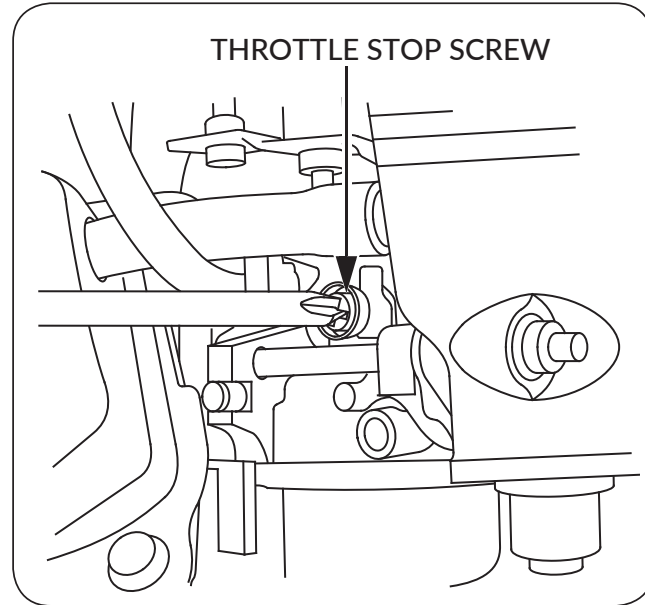

Figure 23

3. Inspect the spark plug. Replace it if the electrodes are worn, or if the insulator is cracked or chipped.
4. Measure the spark plug electrode gap with a suitable gauge. The gap should be 0.028 in - 0.031 in (0.70 mm - 0.80 mm). Correct the gap, if necessary, by carefully bending the side electrode.
5. Install the spark plug carefully, by hand, to avoid cross-threading.
6. After the spark plug seats, tighten with a spark plug wrench to compress the water.

If reinstalling the used spark plug, tighten 1/8 - 1/4 turn after the spark plug seats.

If installing a new spark plug, tighten 1/2 turn after the spark plug seats.

NOTE

A loose spark plug can overheat and damage the engine.

Over tightening the spark plug can damage the threads in the cylinder head.

7. Attach the spark plug cap.

IDLE SPEED ADJUSTMENT

1. Start the engine outdoors, and allow it to warm up to operating temperature.
2. Move the throttle lever to its slowest position.
3. Turn the throttle stop screw to obtain the standard idle speed.

Standard idle speed: 1800±200rpm

STORAGE

STORAGE PREPARATION

Proper storage preparation is essential for keeping your engine trouble free and looking good. The following steps will help to keep rust and corrosion from impairing your engine's function and appearance, and will make the engine easier to start after storage.

CLEANING

If the engine has been running, allow it to cool for at least half an hour before cleaning. Clean all exterior surfaces, touch up any damaged paint, and coat other areas that may rust with a light film of oil.

NOTE Using a garden hose or pressure washing equipment can force water into the air cleaner or muffler opening. Water in the air cleaner will soak the air filter, and water that passes through the air filter or muffler can enter the cylinder, causing damage.

NOTE Water contacting a hot engine can cause damage. If the engine has been running, allow it to cool for at least half an hour before washing.

FUEL

Gasoline will oxidize and deteriorate in storage. Old gasoline will cause hard starting, and it leaves gum deposits that clog the fuel system. If the gasoline in your engine deteriorates during storage, you may need to have the carburetor and other fuel system components serviced or replaced.

Gasoline is mixture of different material. Gasoline left in fuel tank and carburetor will cause functional problems. The causing time varies under different factors, such as storing temperature, fuel tank partially or completely filled. The air in the tank can cause fuel deterioration when fuel tank is partially filled. High storing temperature accelerates fuel deterioration. Fuel deterioration may occur within a few months or even less, when the gasoline is not fresh during refueling.

The Distributor's Limited Warranty does not cover fuel system damage or engine performance problems resulting from neglected storage preparation.

You can extend fuel storage life by adding a fuel stabilizer that is formulated for that purpose, or you can avoid fuel deterioration problems by draining the fuel tank and carburetor.

ADDING A FUEL STABILIZER TO EXTEND FUEL STORAGE LIFE

When adding a fuel stabilizer, fill the fuel tank with fresh gasoline. If only partially filled, air in the tank will promote fuel deterioration

during storage. If you keep a container of gasoline for refueling, be sure that it contains only fresh gasoline.

1. Add fuel stabilizer following the manufacturer's instructions.
2. After adding a fuel stabilizer, run the engine outdoors for 10 minutes to be sure that treated gasoline has replaced the untreated gasoline in the carburetor.
3. Stop the engine, and move the fuel valve to the OFF position.

DRAINING THE FUEL TANK AND CARBURETOR

1. Place an approved gasoline container below the carburetor, and use a funnel to avoid spilling fuel.
2. Remove the carburetor drain bolt and sediment cup, and then move the fuel valve lever to the ON position.

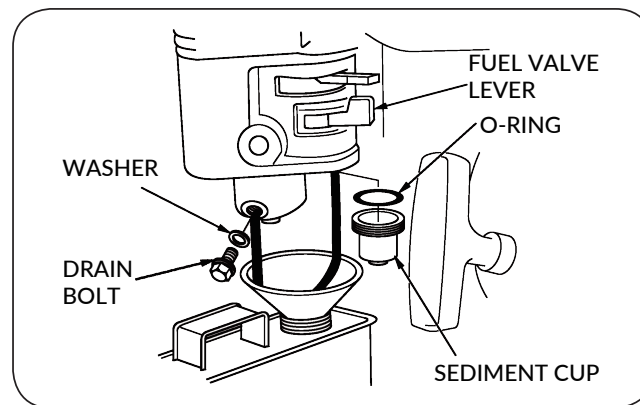

Figure 24

3. After all the fuel has drain into the container, reinstall the drain bolt and sediment cup. Tighten them securely.

STORAGE PRECAUTIONS

1. Change the engine oil.
2. Remove the spark plugs.
3. Pour a tablespoon (5-10 cc) of clean engine oil into the cylinder.
4. Pull the starter rope several times to distribute the oil in the cylinder.
5. Reinstall the spark plugs.
6. Pull the starter rope slowly until resistance is felt. This will close the valves so moisture cannot enter the engine cylinder. Return the starter rope gently.

If your engine will be stored with gasoline in the fuel tank and carburetor, it is important to reduce the hazard of gasoline vapor ignition. Select a well-ventilated storage area away from any appliance that operates with a flame, such as a furnace, water heater, or clothes dryer. Also avoid any area with a spark-producing electric motor, or where power tools are operated.

If possible, avoid storage areas with high humidity, because that promotes rust and corrosion.

Unless all fuel has been drained from the fuel tank, leave the fuel valve lever in the OFF position to reduce the possibility of fuel leakage.

Position the equipment so the engine is level. Tilting can cause fuel or oil leakage.

With the engine and exhaust system cool, cover the engine to keep out dust. A hot engine and exhaust system can ignite or melt some materials. Do not use sheet plastic as a dust cover. A nonporous cover will trap moisture around the engine, promoting rust and corrosion.

If equipped with a battery for an electric starter, recharge the battery once a month while the engine is in storage. This will help to extend the service life of the battery.

REMOVAL FROM STORAGE

Check your engine as described in the chapter CHECK BEFORE OPERATION.

If the fuel was drained during storage preparation, fill the tank with fresh gasoline. If you keep a container of gasoline for refueling, be sure that it contains only fresh gasoline. Gasoline oxidizes and deteriorates over time, causing hard starting.

If the cylinders were coated with oil during storage preparation, the engine may smoke briefly at startup. This is normal.

TRANSPORTING

If the engine has been running, allow it to cool for at least 15 minutes before loading the engine-powered equipment on the transport vehicle. A hot engine and exhaust system can burn you and can ignite some materials.

Keep the engine level when transporting to reduce the possibility of fuel leakage. Move the fuel valve lever to the OFF position.

TROUBLESHOOTING

ENGINE WILL NOT START	Possible Cause	Correction
1. Electric starting: check battery.	Battery discharged.	Recharge battery.
2. Check control positions.	<ol style="list-style-type: none"> 1. Fuel valve OFF. 2. Choke OPEN. 3. Engine switch OFF. 	<ol style="list-style-type: none"> 1. Move lever to ON. 2. Move lever to CLOSE unless engine is warm. 3. Turn engine switch to ON.
3. Check fuel.	<ol style="list-style-type: none"> 1. Out of fuel 2. Bad fuel; engine stored without treating or draining gasoline, or refueled with bad gasoline. 	<ol style="list-style-type: none"> 1. Refuel 2. Drain fuel tank and carburetor. Refuel with fresh gasoline.
4. Remove and inspect spark plugs.	<ol style="list-style-type: none"> 1. Spark plugs faulty, fouled, or improperly gapped 2. Spark plugs wet with fuel (flooded engine). 	<ol style="list-style-type: none"> 1. Gap, or replace spark plugs 2. Dry and reinstall spark plugs Start engine with throttle lever in FAST position.
5. Take engine to an authorized servicing dealer, or refer to manual.	Fuel filter clogged, carburetor malfunction, ignition malfunction, valve stuck, etc.	Replace or repair faulty components as necessary.

ENGINE LACKS POWER	Possible Cause	Correction
1. Check air filter	Filter element(s) clogged.	Clean or replace filter element(s).
2. Check fuel	<ol style="list-style-type: none"> 1. Out of fuel. 2. Bad fuel; engine stored without treating or draining gasoline, or refueled with bad gasoline. 	<ol style="list-style-type: none"> 1. Refuel 2. Drain fuel tank and carburetor Refuel with fresh gasoline.
3. Take engine to an authorized servicing dealer, or refer to manual	Fuel filter clogged, carburetor malfunction, ignition malfunction, valve stuck, etc	Replace or repair faulty components as necessary

TECHNICAL & CONSUMER INFORMATION

CARBURETOR MODIFICATION FOR HIGH ALTITUDE OPERATION

At high altitude, the standard carburetor air-fuel mixture will be too rich. Performance will decrease, and fuel consumption will increase. A very rich mixture will also foul the spark plug and cause hard starting. Operation at an altitude that differs from that at which this engine was certified, for extended periods of time, may increase emissions.

High altitude performance can be improved by specific modifications to the carburetor. If you always operate your engine at altitudes above 5,000 feet (1,500 meters), have your servicing dealer perform this carburetor modification. This engine, when operated at high altitude with the carburetor modifications for high altitude use, will meet each emission standard throughout its useful life.

Even with carburetor modification, engine horsepower will decrease about 3.5% for each 1,000-foot (300-meter) increase in altitude. The effect of altitude on horsepower will be greater than this if no carburetor modification is made.

NOTE *When the carburetor has been modified for high altitude operation, the air-fuel mixture will be too lean for low altitude use. Operation at altitudes below 5,000 feet (1,500 meters) with a modified carburetor may cause the engine to overheat and result in serious engine damage. For use at low altitudes, have your servicing dealer return the carburetor to original factory specifications.*

OXYGENATED FUELS

Some conventional gasolines are being blended with alcohol or an ether compound. These gasolines are collectively referred to as oxygenated fuels. To meet clean air standards, some areas use oxygenated fuels to help reduce emissions.

If you use an oxygenated fuel, be sure it is unleaded and meets the minimum octane rating requirement.

Before using an oxygenated fuel, try to confirm the fuel's contents. Some areas require this information to be posted on the pump.

The following are the EPA approved percentages of oxygenates:

ETHANOL-----(ethyl or grain alcohol) 10% by volume
You may use gasoline containing up to 10% ethanol by volume. Gasoline containing ethanol may be marketed under the name "Gasohol".

MTBE----- (methyl tertiary butyl ether) 15% by volume
You may use gasoline containing up to 15% MTBE by volume.

METHANOL----- (methyl or wood alcohol) 5% by volume You

may use gasoline containing up to 5% methanol by volume, as long as it also contains cosolvents and corrosion inhibitors to protect the fuel system. Gasoline containing more than 5% methanol by volume may cause starting and/or performance problems. It may also damage metal, rubber, and plastic parts of your fuel system.

If you notice any undesirable operating symptoms, try another service station, or switch to another brand of gasoline.

Fuel system damage or performance problems resulting from the use of an oxygenated fuel containing more than the percentages of oxygenates mentioned above are not covered under warranty.

EMISSION CONTROL SYSTEM INFORMATION

Source of Emissions

The combustion process produces carbon monoxide, oxides of nitrogen, and hydrocarbons. Control of hydrocarbons and oxides of nitrogen is very important because, under certain conditions, they react to form photochemical smog when subjected to sunlight. Carbon monoxide does not react in the same way, but it is toxic.

This utilizes lean carburetor settings and other systems to reduce the emissions of carbon monoxide, oxides of nitrogen and hydrocarbons.

Tampering and Altering Tampering with or altering the emission control system may increase emissions beyond the legal limit. Among those acts that constitute tampering are:

- Removal or alteration of any part of the intake, fuel or exhaust systems.
- Altering or defeating the governor linkage or speed-adjusting mechanism to cause the engine to operate outside its design parameters.

Problems That May Affect Emissions

If you are aware of any of the following symptoms, have your engine inspected and repaired by your servicing dealer.

- Hard starting or stalling after starting.
- Rough idle.
- Misfiring or backfiring under load.
- Afterburning (backfiring).
- Black exhaust smoke or high fuel consumption.

Replacement Parts

The emission control systems on your engine were designed, built. We recommend the use of genuine parts whenever you have maintenance done. These original-design replacement parts are manufactured to the same standards as the original parts, so you can be confident of their performance. The use of replacement

parts that are not of the original design and quality may impair the effectiveness of your emission control system.

A manufacturer of an aftermarket part assumes the responsibility that the part will not adversely affect emission performance. The manufacturer or rebuilder of the part must certify that use of the part will not result in a failure of the engine to comply with emission regulations.

Maintenance

Follow the maintenance schedule. Remember that this schedule is based on the assumption that your machine will be used for its designed purpose. Sustained high-load or hightemperature operation, or use in unusually wet or dusty conditions, will require more frequent service.

ENGINE TUNE-UP

ITEM	SPECIFICATION
Spark plug gap	0.028-0.031 in (0.70 mm -0.80 mm)
Valve clearance	IN: 0.15 mm±0.02 mm (cold) EX: 0.20 mm±0.02 mm (cold)
Other specifications	No other adjustments needed

PUBLICATIONS

These publications will give you additional information for maintaining and repairing your engine. You may order them from your engine dealer.

PARTS CATALOG

This manual provides complete, illustrated parts lists.

QUICK REFERENCE INFORMATION

Engine Oil	Type	SAE 10W-30,API SE or SF, for general use
	Capacity	0.4 L
Spark Plug	Type	E6RTC/E6TC
	Gap	0.028 ~ 0.031 in (0.70 ~ 0.80 mm)
Carburetor	Idle speed	1800±200rpm
Maintenance	Each use	Check engine oil. Check air filter.
	First 20 hours	Change engine oil.
	Subsequent	Refer to the maintenance

WIRING DIAGRAMS

Non-electric starting engine with oil protection system.

	IG	E
OFF	○	○
ON		

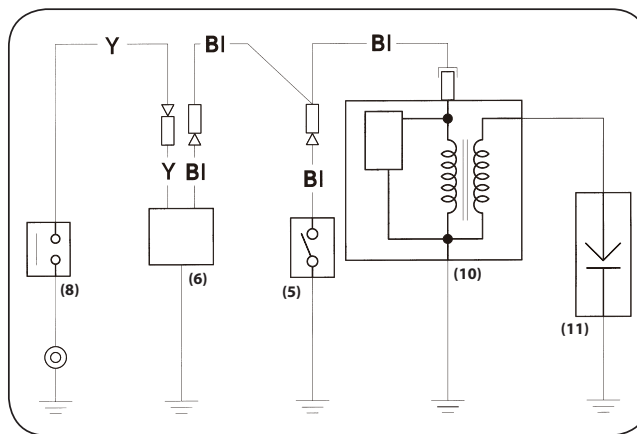

Figure 25

- (5) ENGINE SWITCH
- (6) OIL ALERT UNIT
- (8) OIL LEVEL SWITCH
- (10) IGNITION COIL
- (11) SPARK PLUG

Y	Yellow
Bl	Black

COMBINED EXHAUST AND EVAPORATIVE EMISSIONS CONTROL WARRANTY STATEMENT

YOUR WARRANTY RIGHTS AND OBLIGATIONS

- The United States Environmental Protection Agency and YARDMAX POWER PRODUCTS. (YARDMAX) are pleased to explain the emission control system warranty on your 2026/2027 model year small off-road engine/equipment. In the United States, new small off-road engine/equipments must be designed, built and equipped to meet stringent anti smog standards. YARDMAX must warrant the emission control system on your small off-road engine/equipment for the periods of time listed below provided there has been no abuse, neglect or improper maintenance of your small off-road engine/equipment.
- Where a warrantable condition exists, YARDMAX will repair your small off-road engine/equipment at no cost to you including diagnosis, parts and labor.

MANUFACTURER'S WARRANTY COVERAGE

The exhaust and evaporative emissions control system on your small off-road engine/equipment is warranted for two years. If any emissions-related part on your small off-road engine/equipment is defective, the part will be repaired or replaced by YARDMAX.

OWNER'S WARRANTY RESPONSIBILITIES

- As the small off-road engine/equipment owner, you are responsible for performance of the required maintenance listed in your owner's manual. YARDMAX recommends that you retain all receipts covering maintenance on your small off-road engine/equipment, but YARDMAX cannot deny warranty coverage solely for the lack of receipts or for your failure to ensure the performance of all scheduled maintenance.
- As the small off-road engine/equipment owner, you should however be aware that YARDMAX may deny you warranty coverage if your small off-road engine/equipment or a part has failed due to abuse, neglect, or improper maintenance or unapproved modifications.
- You are responsible for presenting your small off-road engine/equipment to a YARDMAX distribution center or service center as soon as the problem exists. The warranty repairs shall be completed in a reasonable amount of time, not to exceed 30 days.
- If you have any questions regarding your warranty rights and responsibilities, you should contact YARDMAX POWER PRODUCTS. at 844-927-3629 or 844-YARDMAX. The nationwide service E_mail is support@yardmax.com.

DEFECTS WARRANTY REQUIREMENTS

- The warranty period begins on the date the small off-road engine/equipment is delivered to an ultimate purchaser.
- General Emissions Warranty Coverage. YARDMAX warrants to the ultimate purchaser and each subsequent owner that the engine or equipment is:

- (1) Designed, built, and equipped so as to conform with all applicable regulations adopted by the Air Resources Board; and
 - (2) Free from defects in materials and workmanship that causes the failure of a warranted part for a period of two years.
- The warranty on emission-related parts will be interpreted as follows:
 - (1) Any warranted part that is not scheduled for replacement as required maintenance in the written instructions must be warranted for the warranty period defined in Subsection (b)(2). If any such part fails during the period of warranty coverage, it must be repaired or replaced by YARDMAX according to Subsection (4) below. Any such part repaired or replaced under the warranty must be warranted for the remaining warranty period.
 - (2) Any warranted part that is scheduled only for regular inspection in the written instructions must be warranted for the warranty period defined in Subsection (b)(2). A statement in such written instructions to the effect of "repair or replace as necessary" shall advise owners of the warranty coverage for emissions related parts. Replacement within the warranty period is covered by the warranty and will not reduce the period of warranty coverage. Any such part repaired or replaced under warranty must be warranted for the remaining warranty period.
 - (3) Any warranted part that is scheduled for replacement as required maintenance in the written instructions must be warranted for the period of time prior to the first scheduled replacement point for that part. If the part fails prior to the first scheduled replacement, the part must be repaired or replaced by YARDMAX according to Subsection (4) below. Any such part repaired or replaced under warranty must be warranted for the remainder of the period prior to the first scheduled replacement point for the part.
 - (4) Repair or replacement of any warranted part under the warranty provisions must be performed at no charge to the owner at a warranty station.
 - (5) Notwithstanding the provisions of Subsection (4) above, warranty services or repairs must be provided at distribution centers that are franchised to service the subject engine/equipment.
 - (6) The owner must not be charged for diagnostic labor that leads to the determination that a warranted part is in fact defective, provided that such diagnostic work is performed at a warranty station.
 - (7) YARDMAX is liable for damages to other engine/equipment components proximately caused by a failure under warranty of any warranted part.

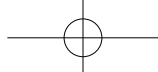

(8) Throughout the emissions control system's warranty period set out in subsection (b)(2), YARDMAX must maintain a supply of warranted parts sufficient to meet the expected demand for such parts and must obtain additional parts if that supply is exhausted.

(9) Manufacturer-approved replacement parts that do not increase the exhaust or evaporative emissions of the engine or emissions control system must be used in the performance of any warranty maintenance or repairs and must be provided without charge to the owner. Such use will not reduce the warranty obligations of YARDMAX.

(10) Add-on or modified parts that are not exempted by the Air Resources Board may not be used. The use of any non-exempted add-on or modified parts will be grounds for disallowing a warranty claim. YARDMAX will not be liable to warrant failures of warranted parts caused by the use of a non-exempted add-on or modified part.

(11) YARDMAX issuing the warranty shall provide any documents that describe that warranty procedures or policies within five working days of request by the Executive Officer.

- Emission Warranty Parts List for Exhaust

- (1) Fuel Metering System

- (i) Carburetor and internal parts (and/or pressure regulator or fuel injection system).
- (ii) Air/fuel ratio feedback and control system.
- (iii) Cold start enrichment system.

- (2) Air Induction System

- (i) Controlled hot air intake system.
- (ii) Intake manifold.
- (iii) Air filter.

- (3) Ignition System

- (i) Spark Plugs.
- (ii) Magneto or electronic ignition system.
- (iii) Spark advance/retard system.

- (4) Exhaust Gas Recirculation (EGR) System

- (i) EGR valve body, and carburetor spacer if applicable.
- (ii) EGR rate feedback and control system.

- (5) Air Injection System

- (i) Air pump or pulse valve.
- (ii) Valves affecting distribution of flow.
- (iii) Distribution manifold.

- (6) Catalyst or Thermal Reactor System

- (i) Catalytic converter.
- (ii) Thermal reactor.

- (iii) Exhaust manifold.

- (7) Particulate Controls

- (i) Traps, filters, precipitators, and any other device used to capture particulate emissions.

- (8) Miscellaneous Items Used in Above Systems

- (i) Electronic controls.
- (ii) Vacuum, temperature, and time sensitive valves and switches.
- (iii) Hoses, belts, connectors, and assemblies.

- Emission Warranty Parts List for Evap

- (1) Fuel Tank
- (2) Fuel Cap
- (3) Fuel Lines (for liquid fuel and fuel vapors)
- (4) Fuel Line Fittings
- (5) Clamps*
- (6) Pressure Relief Valves*
- (7) Control Valves*
- (8) Control Solenoids*
- (9) Electronic Controls*
- (10) Vacuum Control Diaphragms*
- (11) Control Cables*
- (12) Control Linkages*
- (13) Purge Valves*
- (14) Gaskets*
- (15) Liquid/Vapor Separator
- (16) Carbon Canister
- (17) Canister Mounting Brackets
- (18) Carburetor Purge Port Connector

* Note: As they relate to the evaporative emission control system.

- YARDMAX will furnish with each new small off-road engine/equipment written instructions for the maintenance and use of the engine/equipment by the owner.

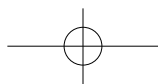
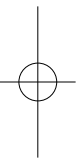
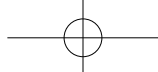

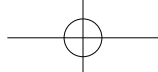

yardmax.com

Tame the Great Outdoors®



844-927-3629 or 844-YARDMAX | support@yardmax.com