

User's Manual

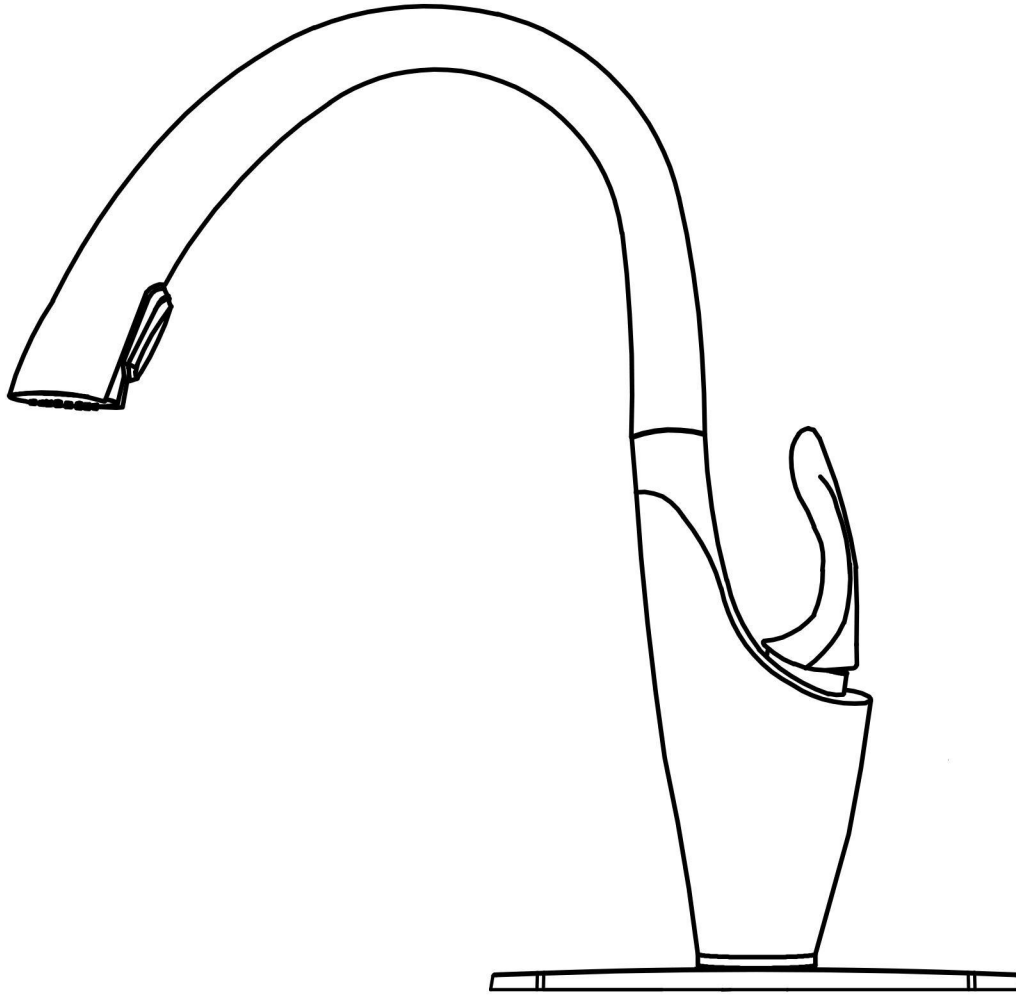

INSTALLATION INSTRUCTIONS

Installation Manual



IAPMO RESEARCH AND TESTING, INC.
5001 East Philadelphia Street, Ontario, California 91761-2816 - USA • 909-472-4100 • 909-472-4244 • www.iapmort.org

CERTIFICATE OF LISTING

 IAPMO Research and Testing, Inc. is a product certification body which tests and inspects samples taken from the supplier's stock or from the market or a combination of both to verify compliance to the requirements of applicable codes and standards. This activity is coupled with periodic surveillance of the manufacturer's production process, including an annual factory audit, to ensure the approval of the Product Certification Committee, or any successor organization, and to ensure that the manufacturer's production process continues to conform to the requirements of the applicable codes and standards. This listing is subject to the conditions set forth in the applicable codes and standards and is not to be construed as any recommendation, assurance or guarantee by IAPMO Research and Testing, Inc. or the product certification body.

This certificate is not evidence of current listing. To verify listing status, visit the IAPMO R&T Product Listing Directory at pld.iapmo.org

Effective Date: December 2019 -Rev. 2/24/2020- Void After: December 2024
Product: Flexible Water Connectors File No. 5111
Issued To: Fanak Group Inc.
Mechanical & Electrical
Industrial Zone,
Yuhuan County,
Yuhuan 317600, ZHEJIANG
China

Identification: Products shall be marked with manufacturer's name or trademark, a statement "For use with water in accessible locations only." The products shall also bear the cUPC® certification mark. Markings shall be by means of either a permanent mark on the product, a label on the product or a tag attached to the product.

Characteristics: Flexible water connectors manufactured in various sizes, lengths and metal and fittings for hot or cold water applications that consist of an inner tube, which may or may not have an outer braided cover. Connectors are to be installed for use in accessible locations only. To be installed in accordance with the manufacturer's instruction, and the latest edition of the Uniform Plumbing Code and National Plumbing Code of Canada.

Products listed on this certificate have been tested by an IAPMO R&T recognized laboratory. This recognition has been granted based upon the

 
Chairman, Product Certification Committee CEO, The IAPMO Group

This listing is based upon the test data of the month indicated on the Effective Date and Void After Date shown above. Any change in material, manufacturing process, marking or design without written approval of the Product Certification Committee, or any successor organization, shall constitute a change in the product. Production of or reference to this form for advertising purposes may be made only by specific, written permission of IAPMO Research and Testing, Inc. Any alteration of this certificate could be grounds for revocation of the listing. This document shall be reproduced in its entirety.



IAPMO RESEARCH AND TESTING, INC.
5001 East Philadelphia Street, Ontario, California 91761-2816 - USA • 909-472-4100 • 909-472-4244 • www.iapmort.org

CERTIFICATE OF LISTING

 IAPMO Research and Testing, Inc. is a product certification body which tests and inspects samples taken from the supplier's stock or from the market or a combination of both to verify compliance to the requirements of applicable codes and standards. This activity is coupled with periodic surveillance of the manufacturer's production process, including an annual factory audit, to ensure the approval of the Product Certification Committee, or any successor organization, and to ensure that the manufacturer's production process continues to conform to the requirements of the applicable codes and standards. This listing is subject to the conditions set forth in the applicable codes and standards and is not to be construed as any recommendation, assurance or guarantee by IAPMO Research and Testing, Inc. or the product certification body.

This certificate is not evidence of current listing. To verify listing status, visit the IAPMO R&T Product Listing Directory at pld.iapmo.org

Effective Date: November 2019 Void After: November 2024
Product: Plumbing Fixture Fittings File No. 10613
Issued To: Aqua Gallery Co., Ltd
118-118A 15th Block
International Dynamics
Sanitary City, 528000
Foshan,
China

Identification: Plumbing supply fittings complying with this Standard shall be marked with the manufacturer's recognized name, trademark, or other mark or, in the case of private labeling, the name, trademark or other mark of the customer for whom the fitting was manufactured. The marking shall be accomplished by use of a permanent mark or by placing a permanent label on the product. Markings on plumbing supply fittings shall be visible after installation.

Single-handle, single-control, and automatic compensating mixing bath and shower valves shall have identifiable temperature control settings in which the settings are indicated by words ("cold", "warm", "hot", etc.), by numbers, or graphically.

Packages shall be marked with the manufacturer's name, trademark, or other mark as well as the model number or, in the case of private

 
Chairman, Product Certification Committee CEO, The IAPMO Group

This listing is based upon the test data of the month indicated on the Effective Date and Void After Date shown above. Any change in material, manufacturing process, marking or design without written approval of the Product Certification Committee, or any successor organization, shall constitute a change in the product. Production of or reference to this form for advertising purposes may be made only by specific, written permission of IAPMO Research and Testing, Inc. Any alteration of this certificate could be grounds for revocation of the listing. This document shall be reproduced in its entirety.



IAPMO RESEARCH AND TESTING, INC.
5001 East Philadelphia Street, Ontario, California 91761-2816 - USA • 909-472-4100 • 909-472-4244 • www.iapmort.org

CERTIFICATE OF LISTING

 IAPMO Research and Testing, Inc. is a product certification body which tests and inspects samples taken from the supplier's stock or from the market or a combination of both to verify compliance to the requirements of applicable codes and standards. This activity is coupled with periodic surveillance of the manufacturer's production process, including an annual factory audit, to ensure the approval of the Product Certification Committee, or any successor organization, and to ensure that the manufacturer's production process continues to conform to the requirements of the applicable codes and standards. This listing is subject to the conditions set forth in the applicable codes and standards and is not to be construed as any recommendation, assurance or guarantee by IAPMO Research and Testing, Inc. or the product certification body.

This certificate is not evidence of current listing. To verify listing status, visit the IAPMO R&T Product Listing Directory at pld.iapmo.org

Effective Date: March 2019 Void After: March 2024
Product: Plumbing Fixture Fittings - Components File No. MC-9703
Issued To: Ningbo Hantai Cartridge Technology Co., Ltd.
Liaison Zone, Chuning
Fenghua 311538
China

Identification: Each fitting component shall bear permanent legible markings to identify the manufacturer. This marking shall be the trade name, trademark, or other mark known to identify the manufacturer. The product shall also bear all other markings required by the standards. The marking shall be applied so as to be visible after installation. The product or packaging shall also bear the cUPC® certification mark along with the term "COMPONENT" above.

Characteristics: Plumbing fixture fitting components to be installed in accordance with the manufacturer's instructions and the requirements of the latest edition of the Uniform Plumbing Code.

Products listed on this certificate have been tested by an IAPMO R&T recognized laboratory. This recognition has been granted based upon the Laboratory's compliance to the applicable requirements of ISO/IEC 17025.

Products are in compliance with the following code(s):
Uniform Plumbing Code (UPC®)

 
Chairman, Product Certification Committee CEO, The IAPMO Group

This listing is based upon the test data of the month indicated on the Effective Date and Void After Date shown above. Any change in material, manufacturing process, marking or design without written approval of the Product Certification Committee, or any successor organization, shall constitute a change in the product. Production of or reference to this form for advertising purposes may be made only by specific, written permission of IAPMO Research and Testing, Inc. Any alteration of this certificate could be grounds for revocation of the listing. This document shall be reproduced in its entirety.



BEFORE INSTALLATION

This product has been inspected and debugged by the factory to the best condition. Please do not disassemble and assemble it yourself.

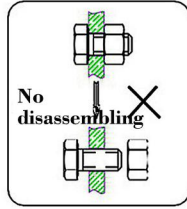

Before installing the faucet, please be sure to remove sundries and sludge from the water pipe to prevent sundries from blocking the faucet.

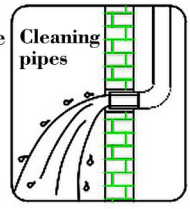

A. Make sure you have all necessary parts by checking the diagram and parts list.

B. Turn off the hot and cold water supply at the angle stops and turn on the old faucet to release any built up pressure. Remove existing faucet. Clean sink or countertop in preparation for new faucet.

C. Shut off angle stops.

D. Pre-drilled hole size requirement: 1-3/8"(min)-1-1/2"(max)

Max countertop thickness without deck plate: 1-1/2"(1 hole install)

Max countertop thickness with deck plate: 1"(1, 2 or 3 hole install)

1/16" (1 mm) min
1-1/2" (38 mm) max

φ 1-3/8" (35mm) min
φ 1-1/2" (38 mm) max

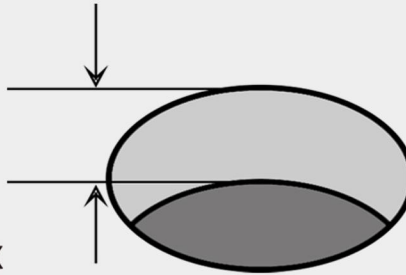

1/16" (1 mm) min
1" (25.4 mm) max

φ 1-3/8" (35mm) min
φ 1-1/2" (38 mm) max

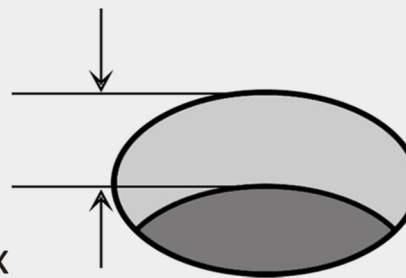

Tools you will need:



Adjustable Wrench



Safety Goggles



Bucket

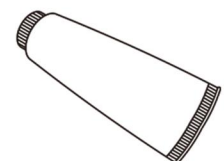

Silicone Sealant

INSTALLATION STEPS

1. Without Deck Plate

Slide the washer(o-ring) to faucet base. Insert the faucet through sink hole.

With Deck Plate

Slide the washer(o-ring), deck & putty plate to faucet base. Insert the faucet through sink hole.

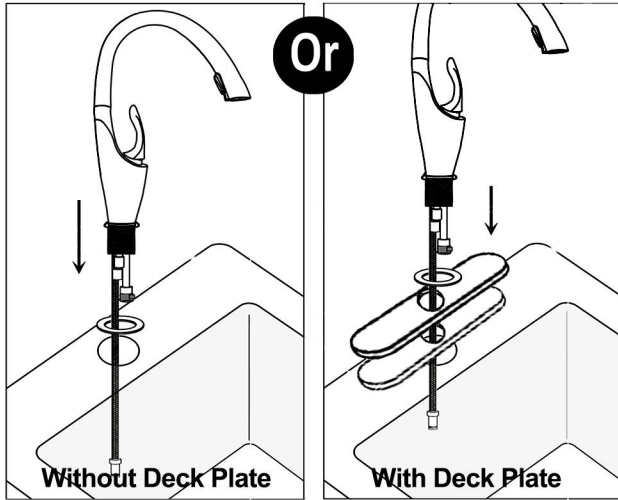

2. Put the washer on screw nut. Screw the nut onto thread. Before tighten, rotate the hand to the side you like, then tighten the nut securely.

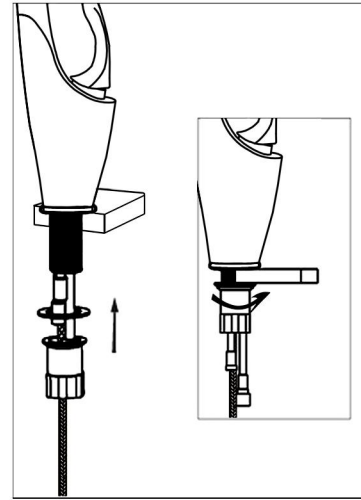

3. Correct and tighten hot and cold water hose. Note: A small rubber o-ring is put into each connector of the hot & cold waterlines, please check before tighten hot and cold water hose.

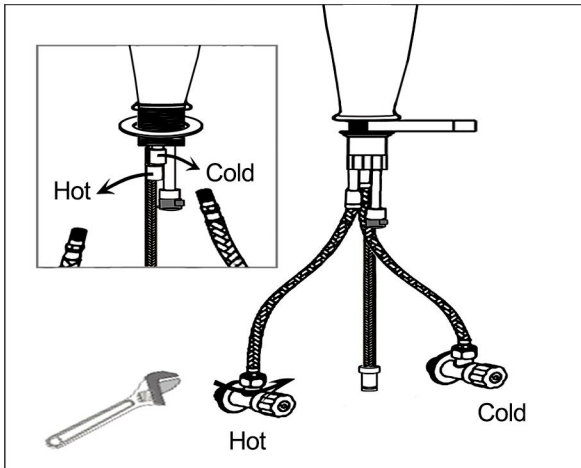

4. Push the sprayer hose to the quick connect. Note: please do not use the tape for the quick connect.

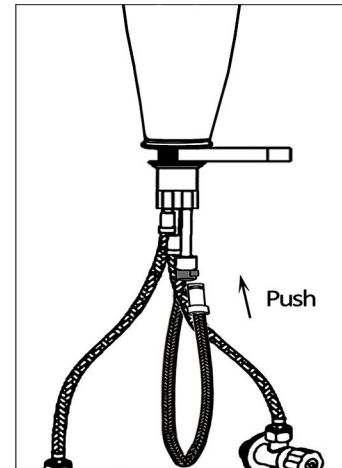

5. Open the weight, put it on sprayer hose. Then close it. Note: To make sure that the pull out hose go back smoothly, you need to adjust the weight in right position.

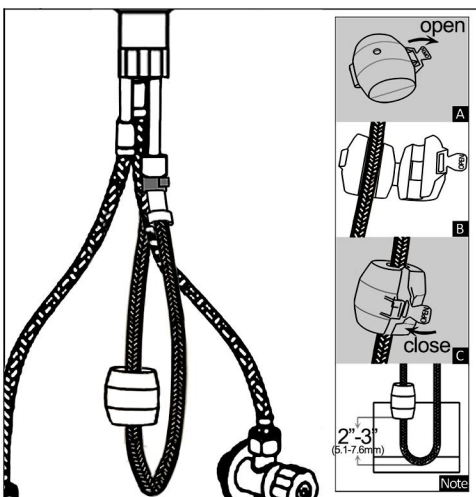

6. Place handle in off position. Screw off the sprayer head. Note: Don't lost the o-ring filter.

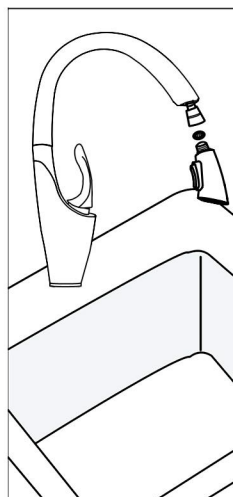

7. Turn on water supply. Check for leaks and flush hoses and flush the faucet for 30s.

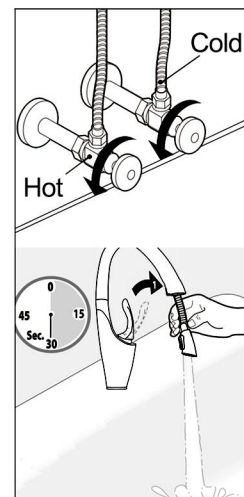

INSTALLATION STEPS

8. Turn off the faucet, screw the sprayer head back the sprayer hose.

Note: Don't forget the o-ring filter.

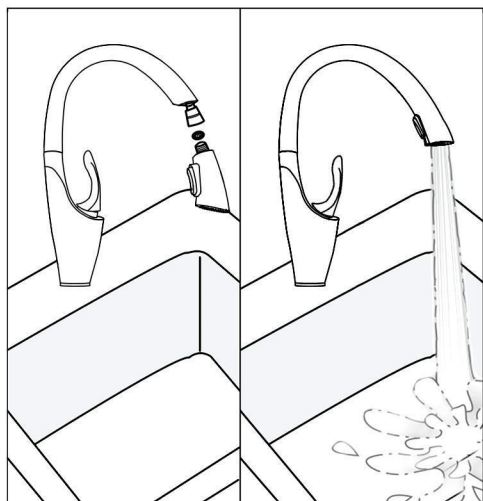

INSTALLATION DIMENSION

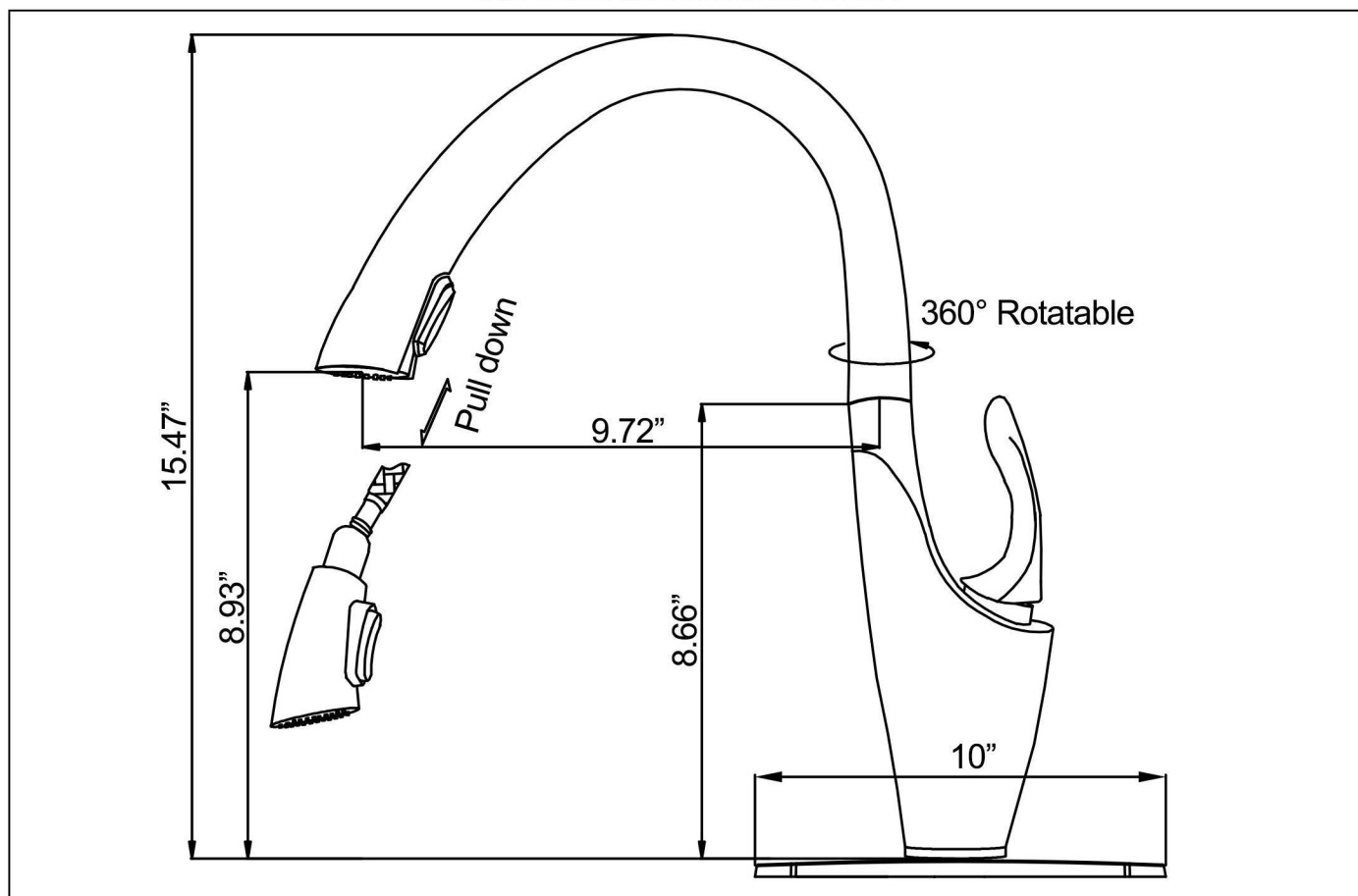

CLEANING CARE

In order to keep the appearance of faucet clean, bright and good performance, please take care of the faucet as follows;

1. Rinse with water only and dry with soft cotton cloth;
2. Use mild liquid and colorless glass cleaner to remove surface dirt and scale film, or use polish without abrasive effect;
3. Do not use abrasive detergent, polish, emery cloth, paper towel or scraper, etc.;
4. Do not use acid cleaner, or cleaner and soap with insoluble gran etc.;
5. In the process of use, mud may accumulate in the bubbler and make the water flow show, The bubbler can be unscrewed, rinsed with water, and then installed back in place.



