

# DJYC2530

ASSEMBLY INTRODUCTION

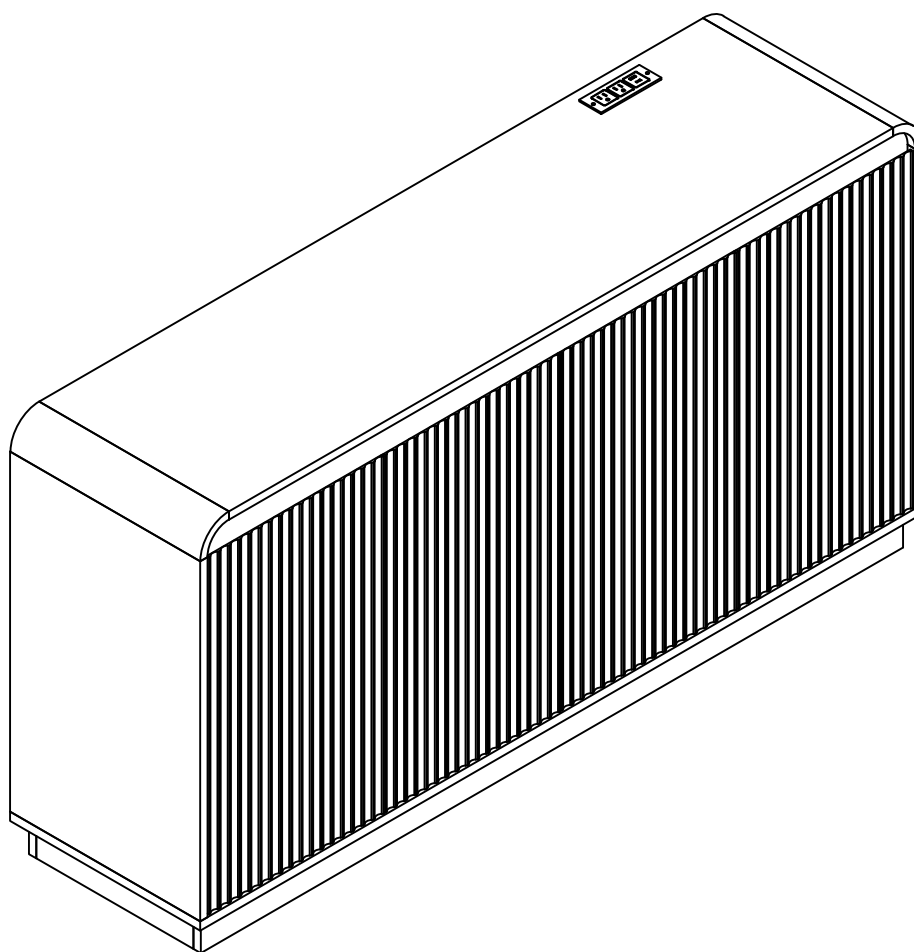

# Exploded View

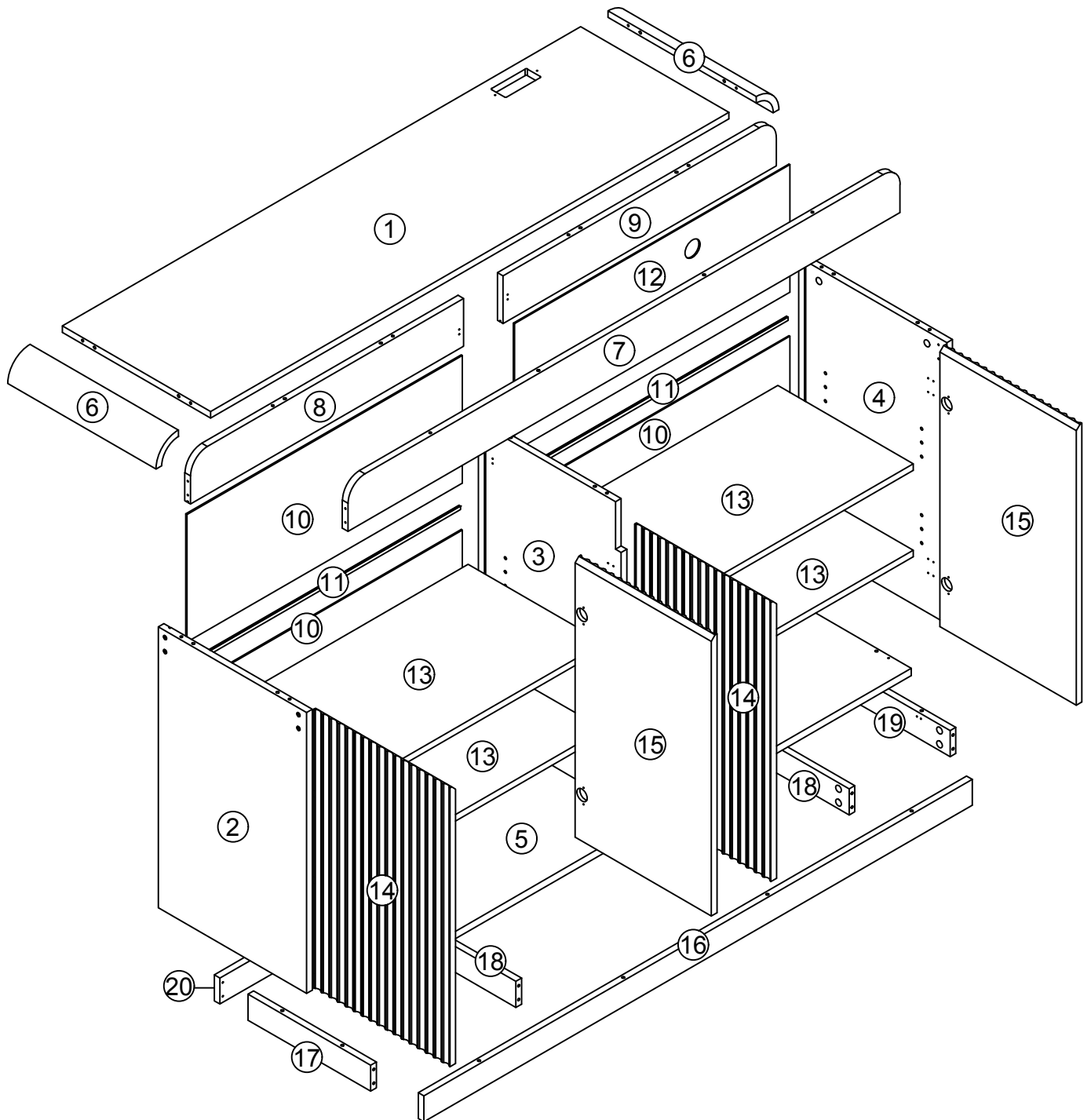

# Fitting

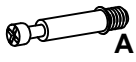

**A x 16**  
M6 x 35 mm



**B x 24**  
φ15 x 10 mm



**C x 34**  
φ6 x 30 mm



**D x 24**  
φ4 x 35 mm



**E x 108**  
φ3.5 x 12 mm



**F x 15**



**G x 16**  
φ3 x 16 mm



**H x 2**  
φ6 x 30 mm



**I x 2**  
φ4 x 14 mm



**J x 8**



**K x 1**



**L x 2**  
φ3.5 x 12 mm



**M x 16**



**N x 4**

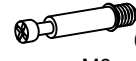

**O x 8**  
M6 x 40 mm



**P x 4**

# Step 1

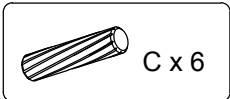
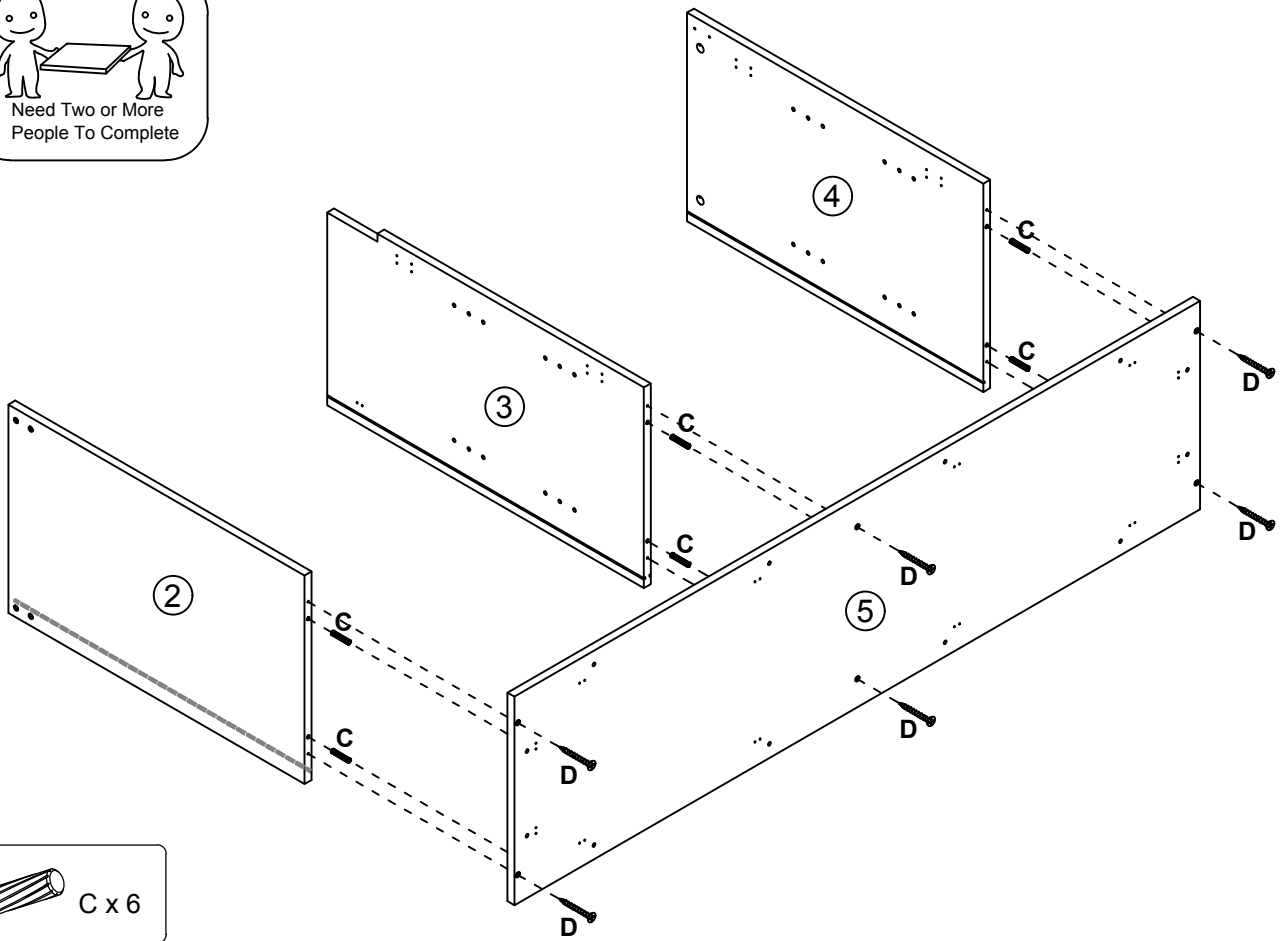
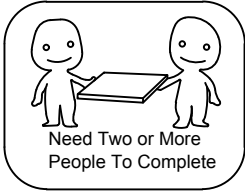

# Step 2

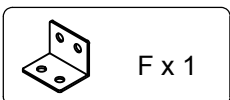
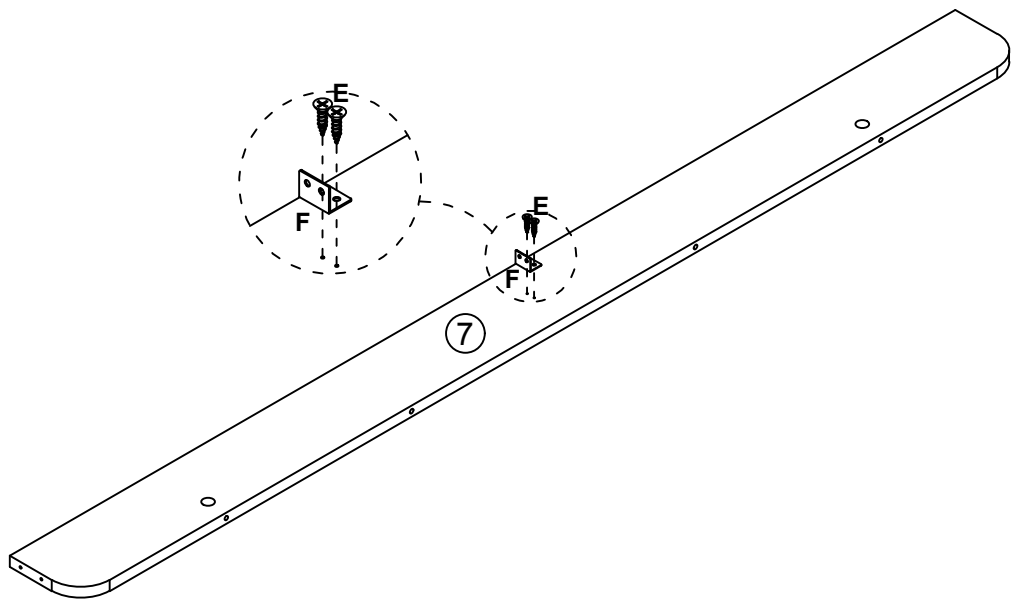

### Step 3

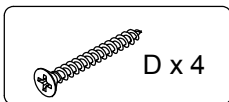
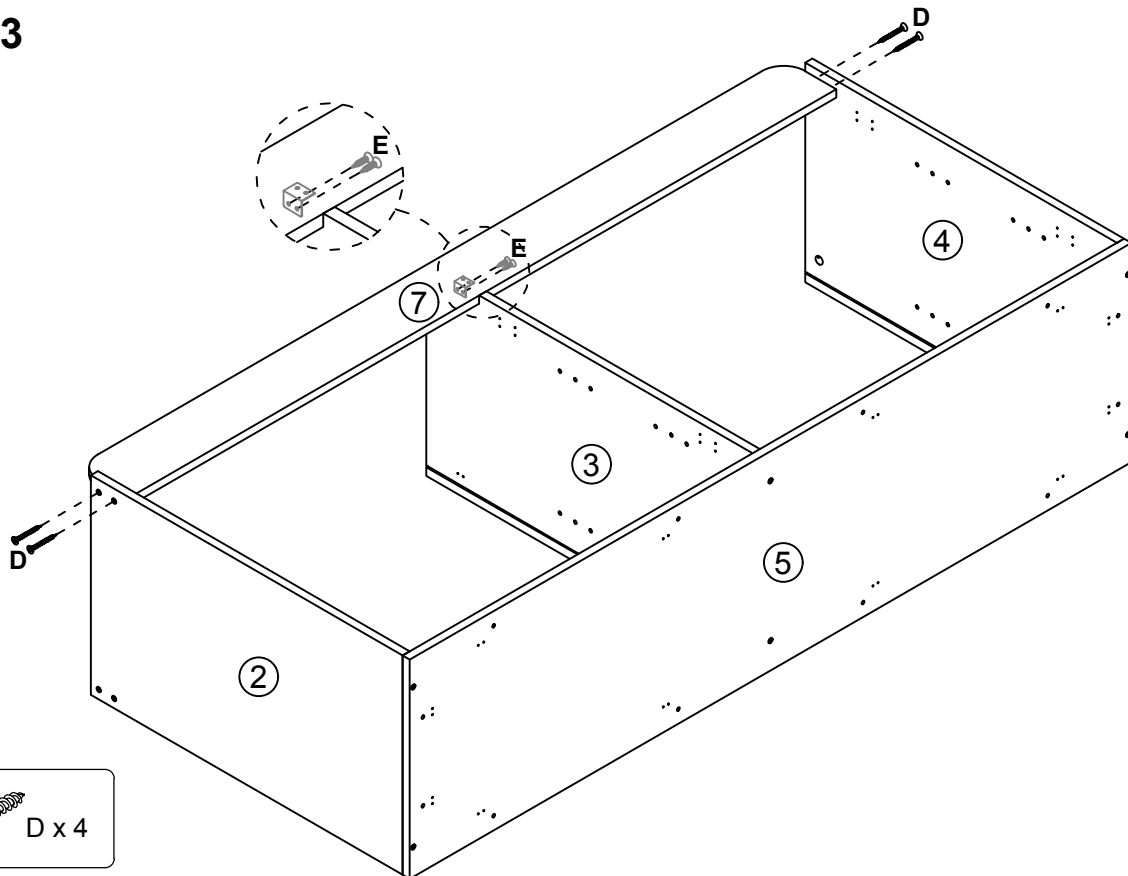

### Step 4

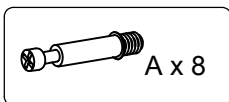
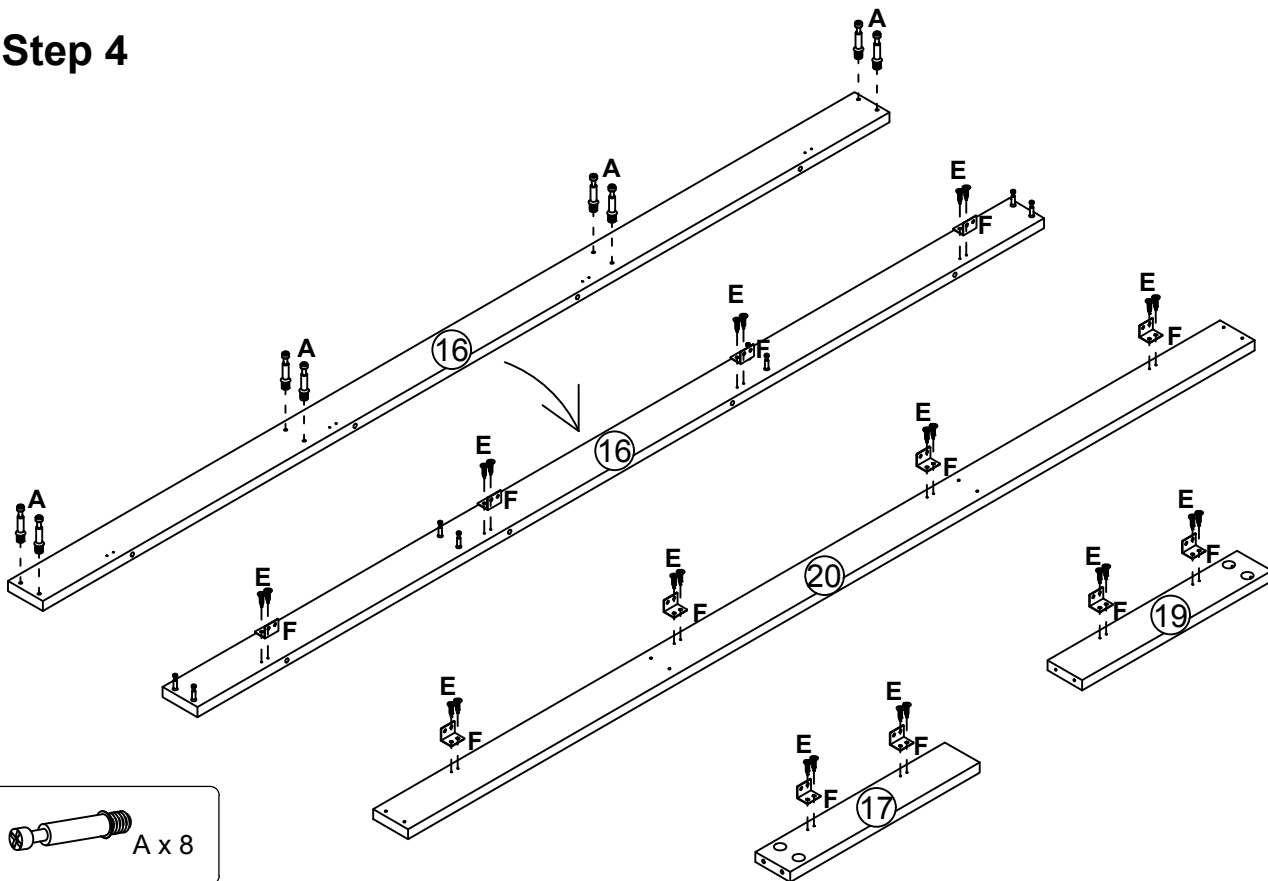

## Step 5

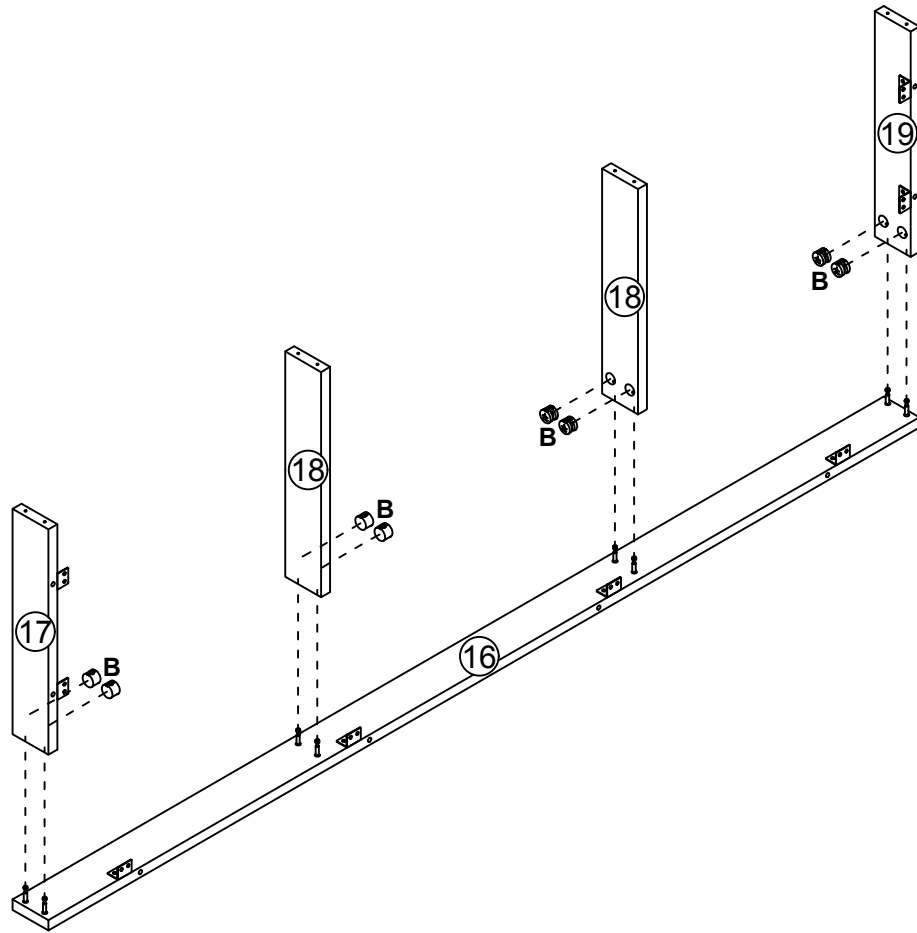

B x 8

## Step 6

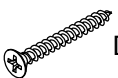
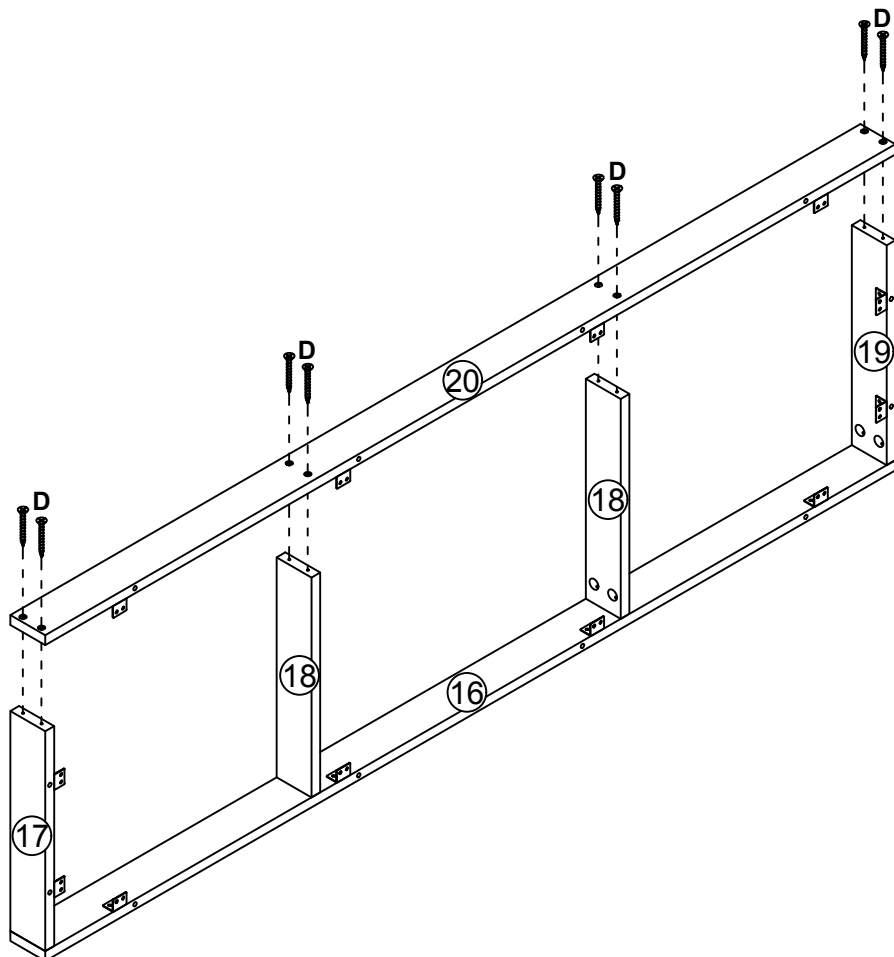

D x 8

# Step 7

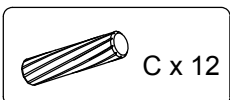
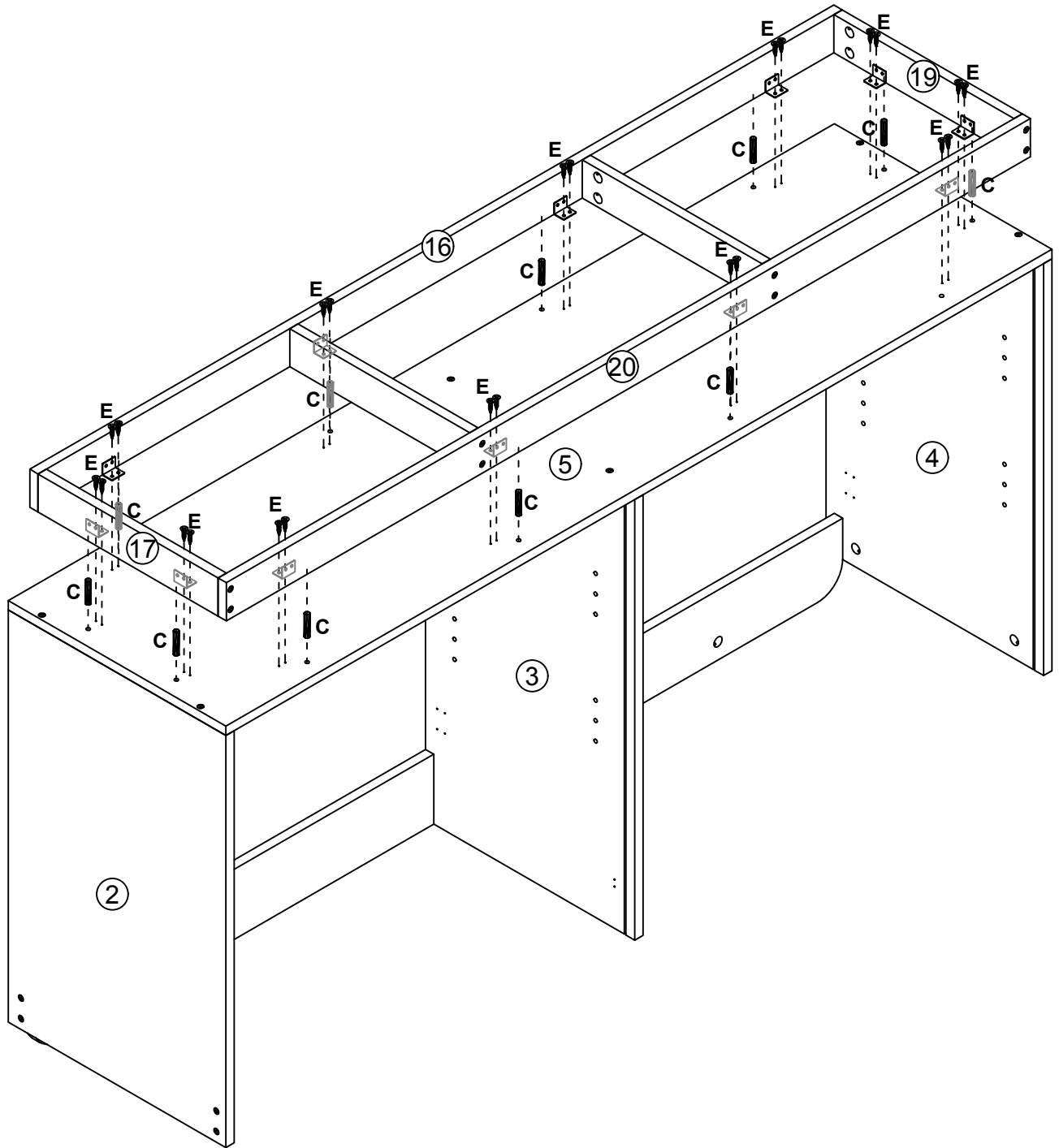
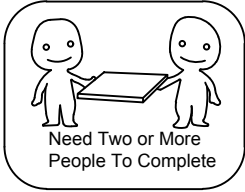

## Step 8

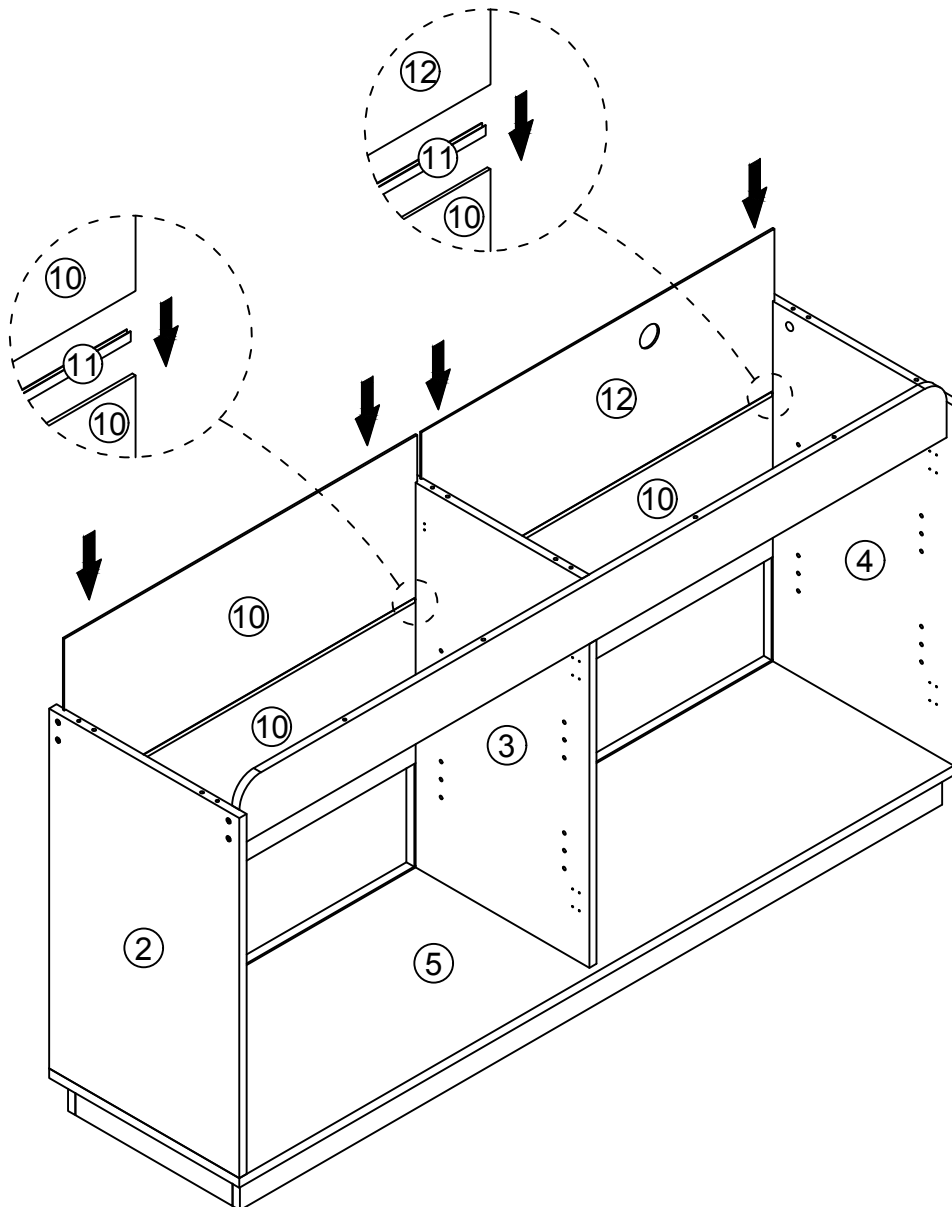

## Step 9

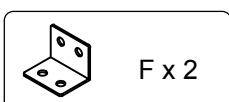
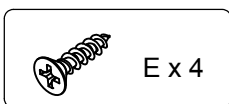
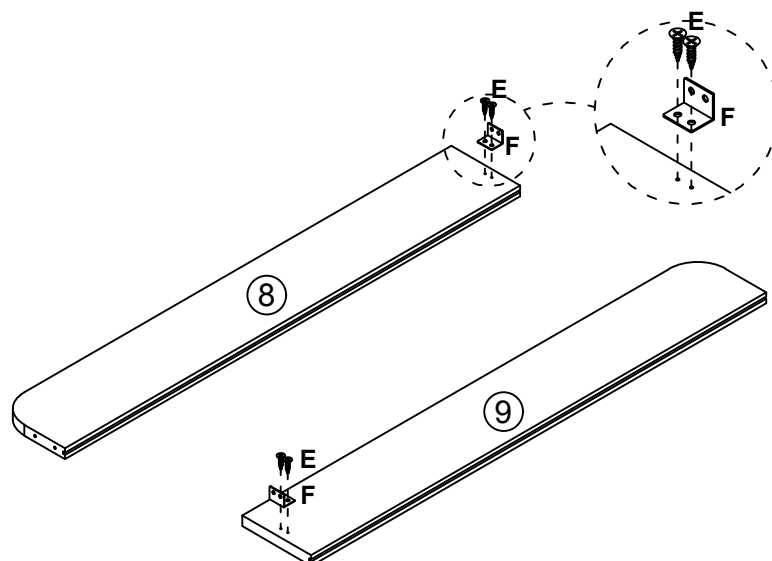

## Step 10

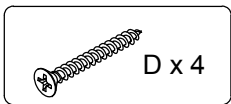
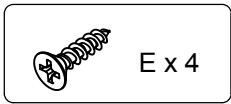
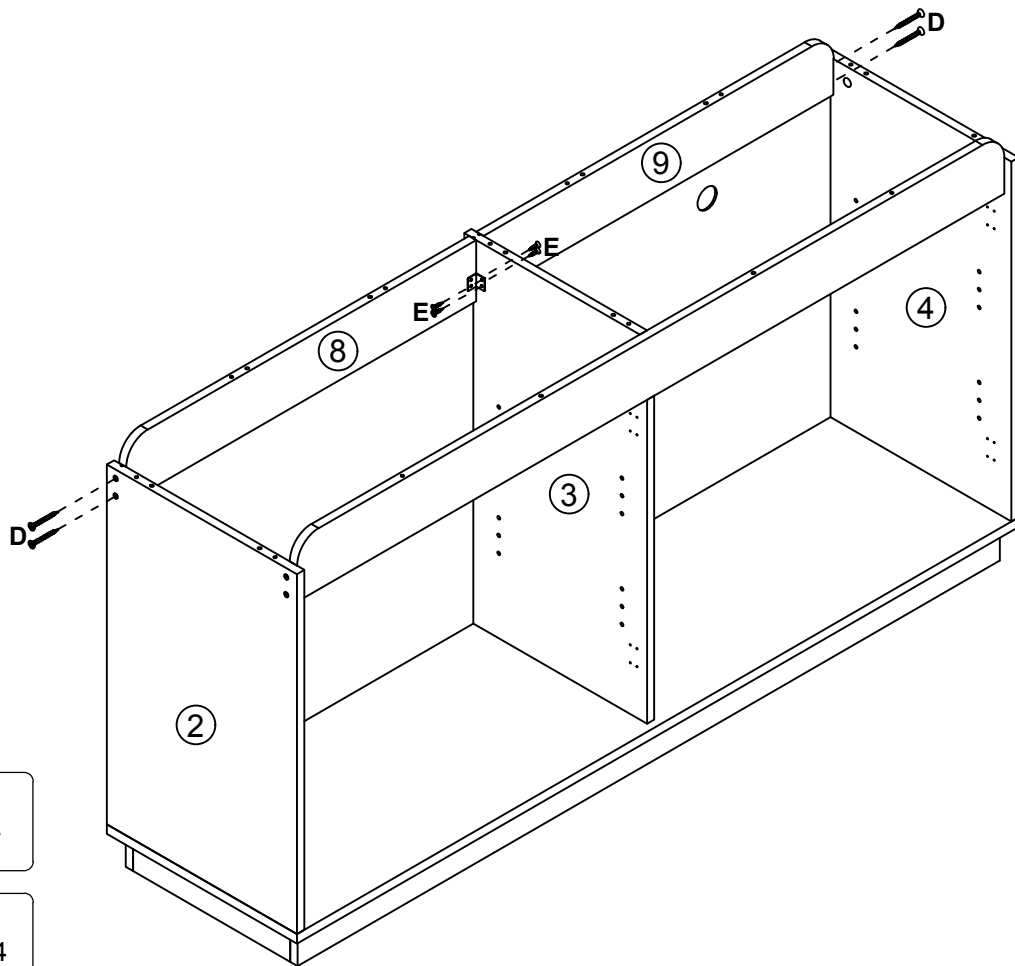

## Step 11

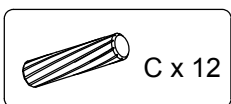
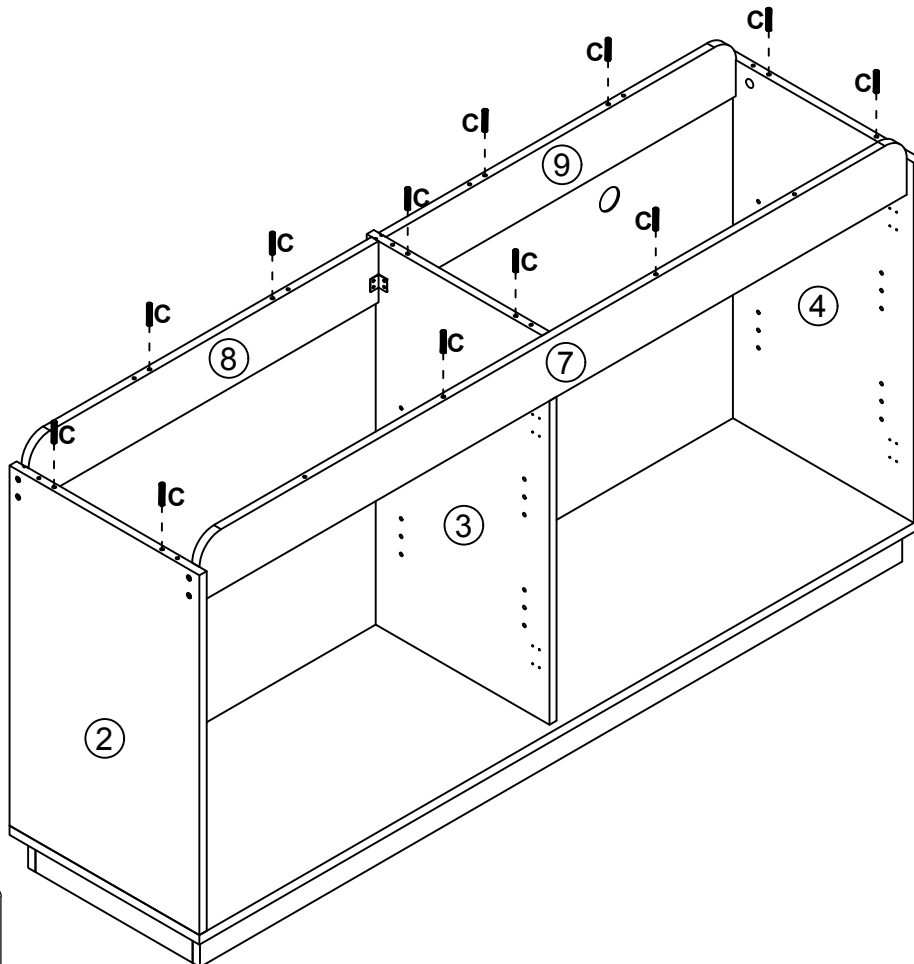

## Step 12

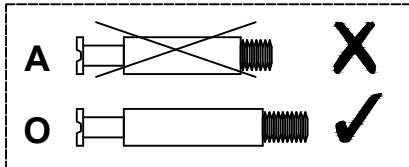
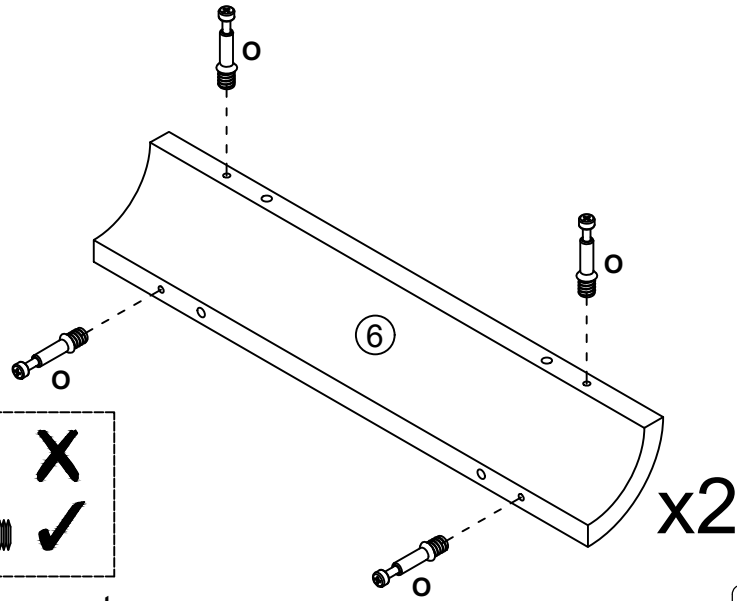

Caution :Need to use the correct part #O instead of part #A.

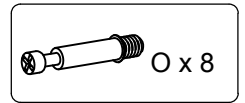

## Step 13

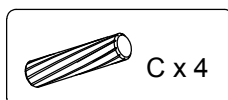
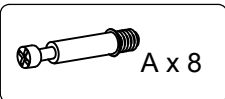
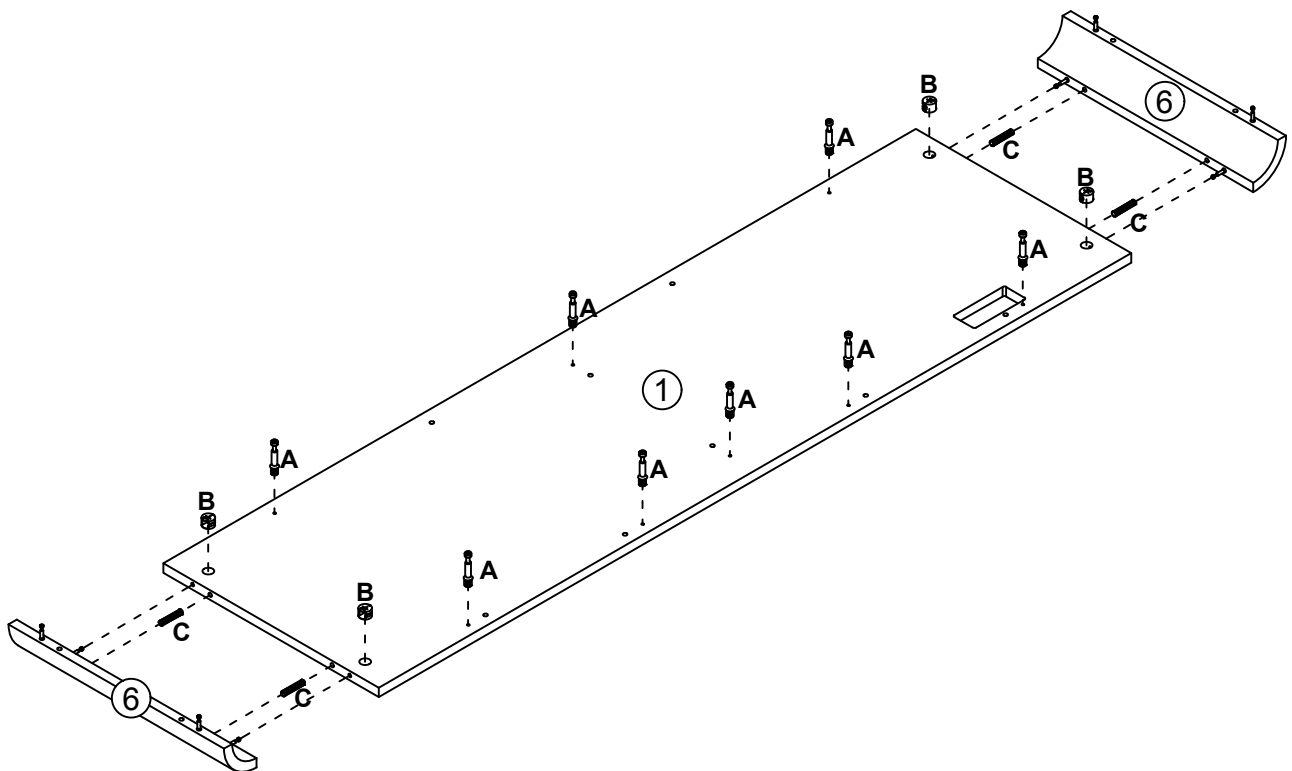

# Step 14

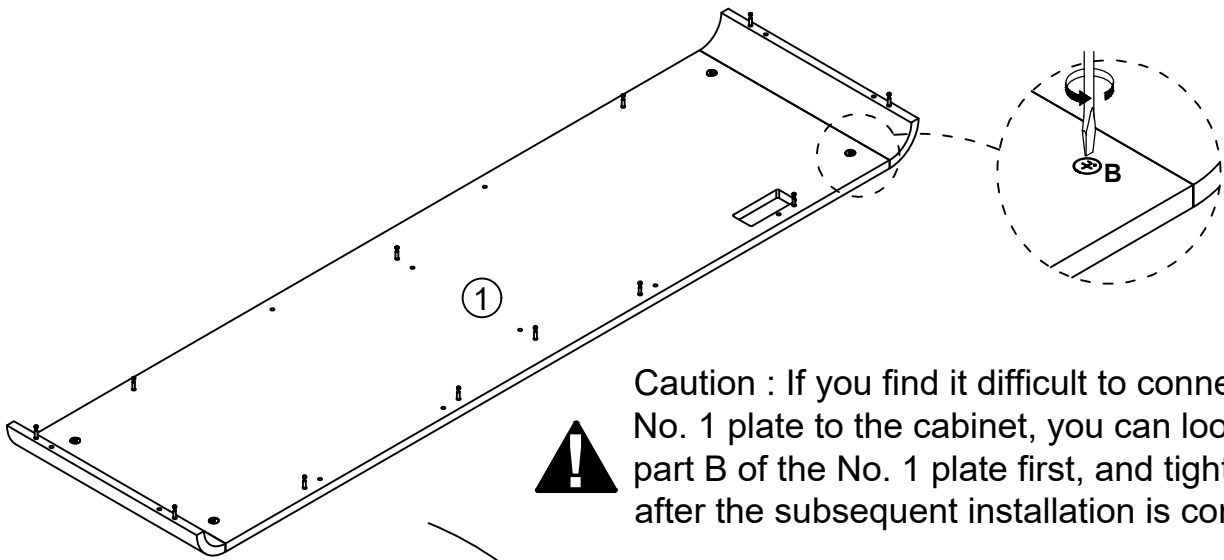

Caution : If you find it difficult to connect the No. 1 plate to the cabinet, you can loosen part B of the No. 1 plate first, and tighten it after the subsequent installation is completed.

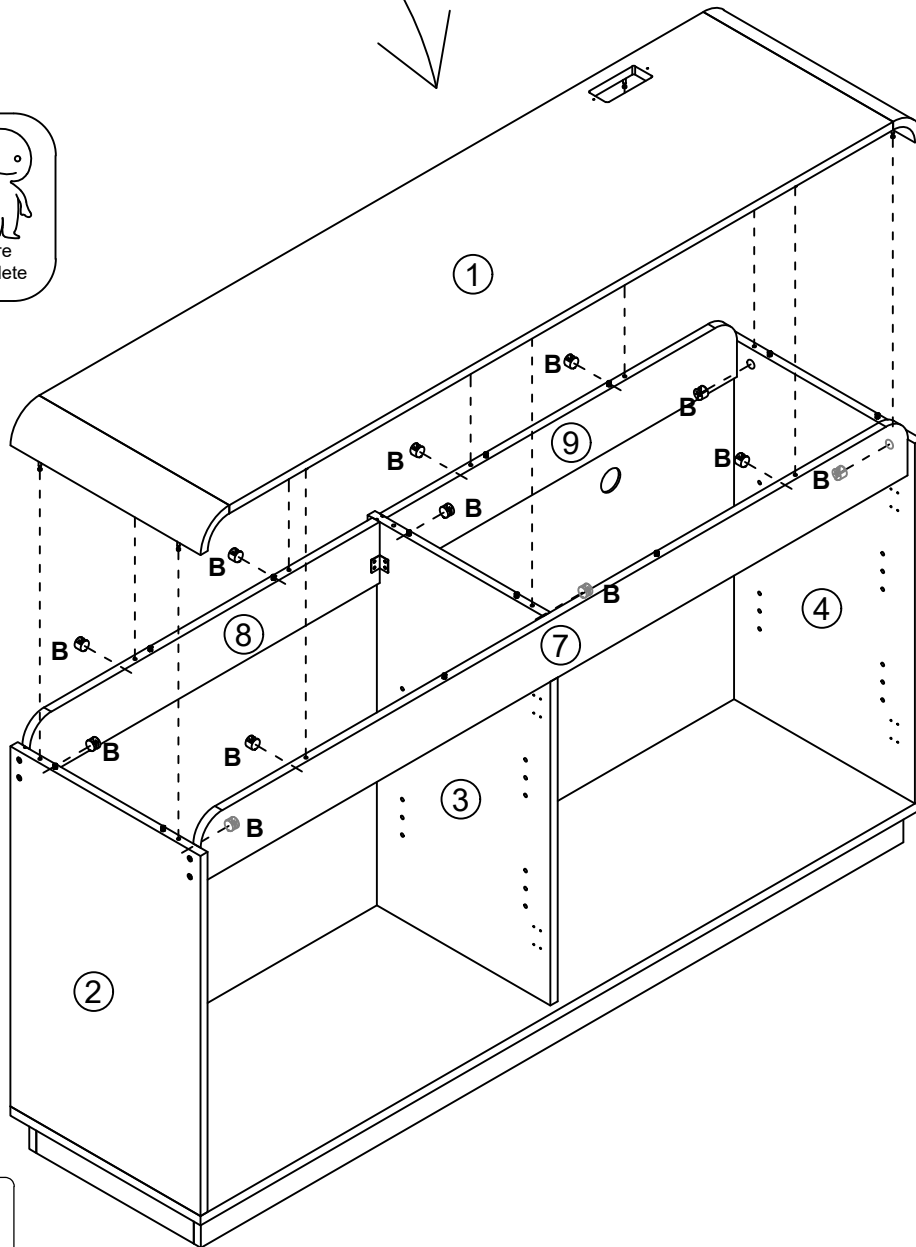
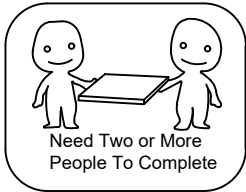

# Step 15

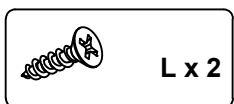
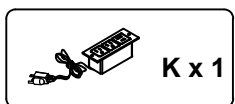
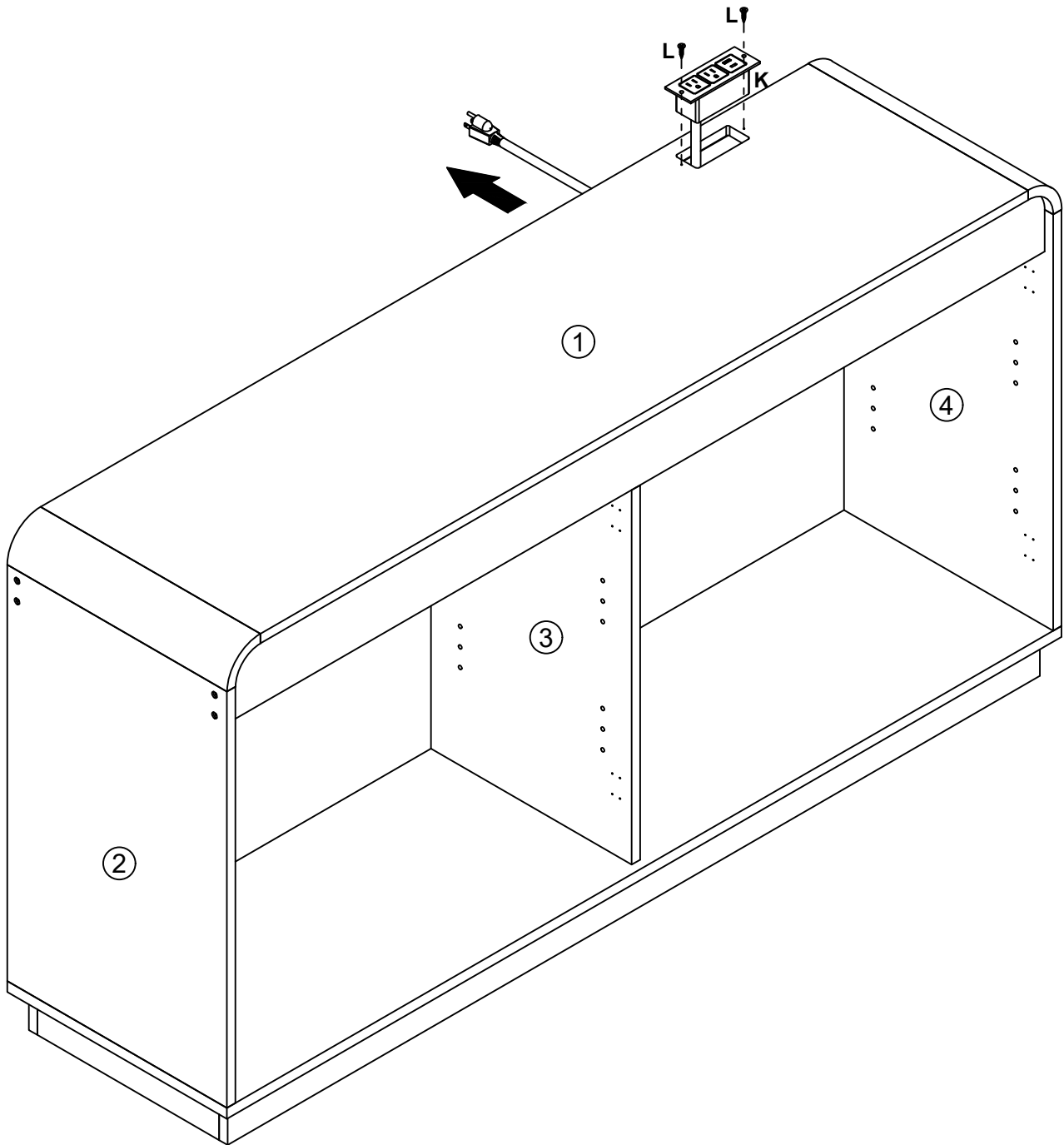

# Step 16

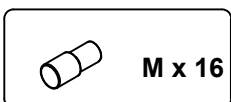
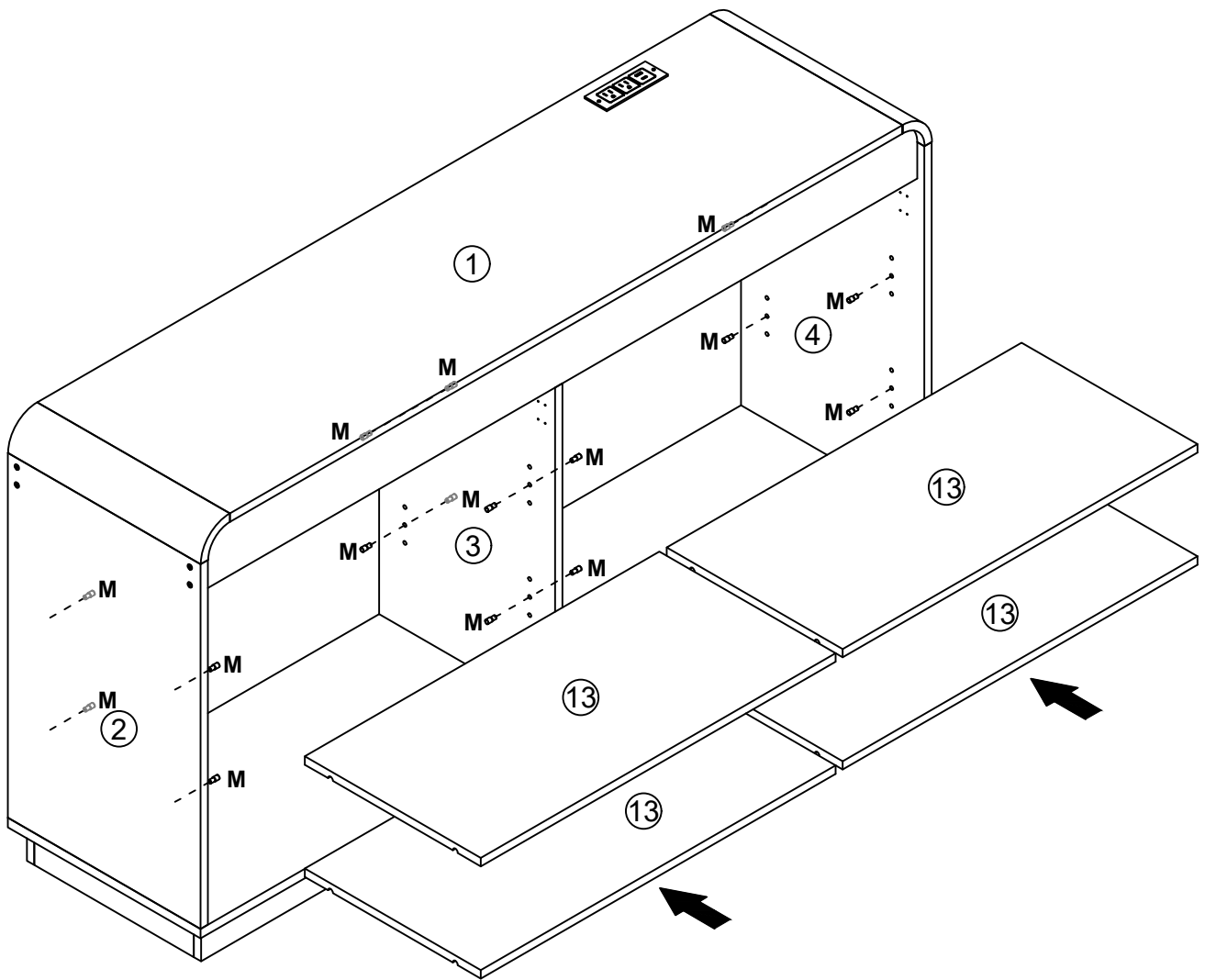

## Step 17

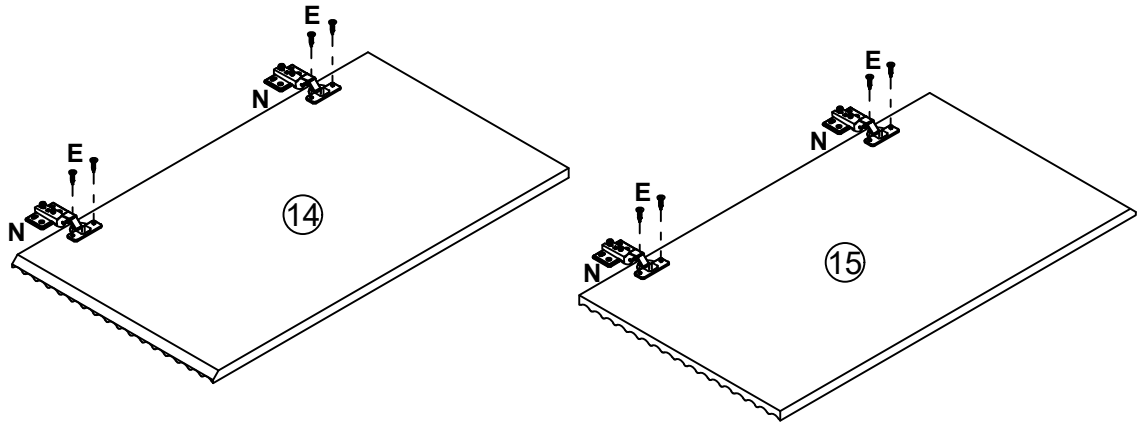

E x 8



N x 4

## Step 18

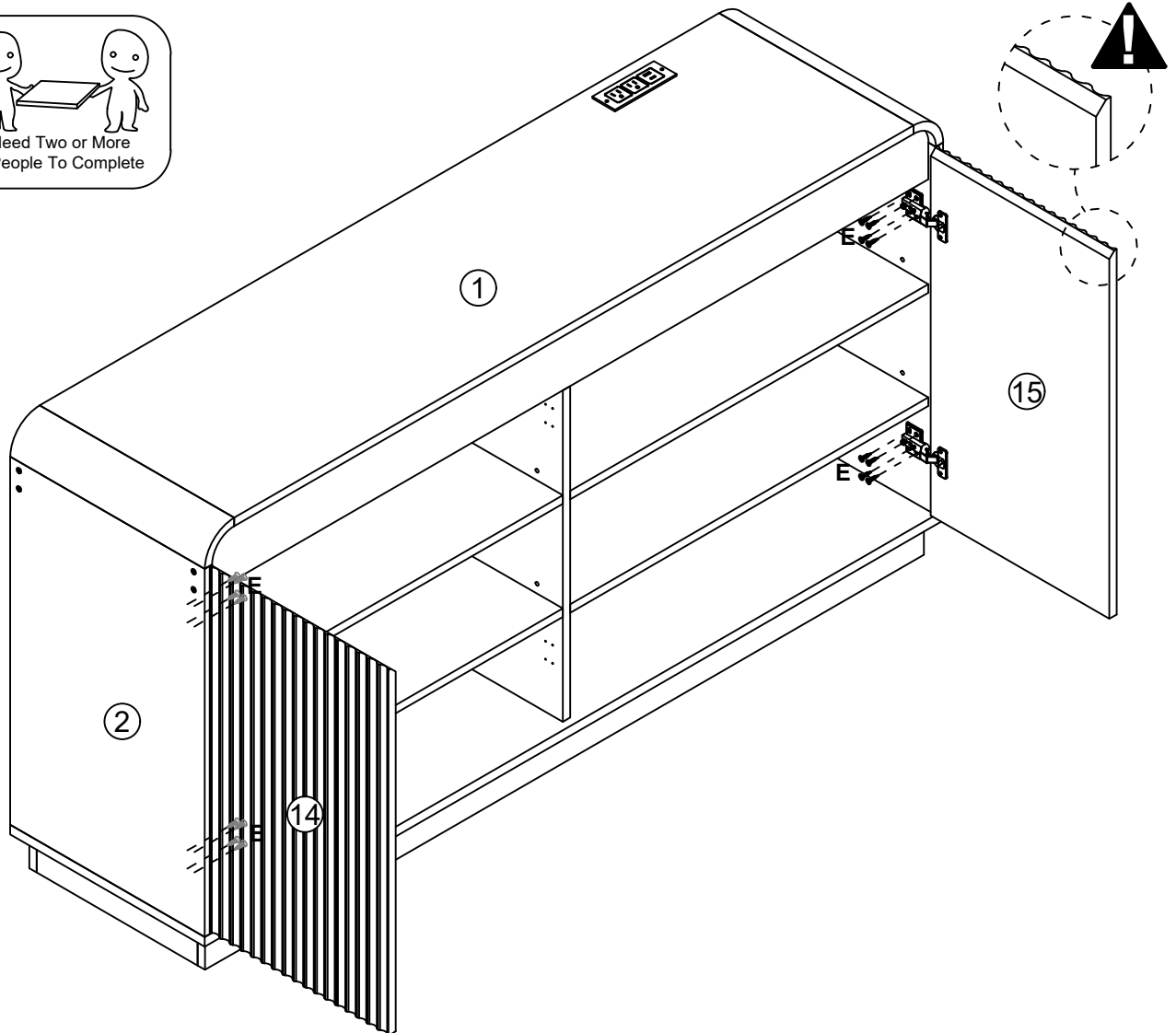
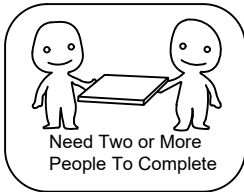

E x 16

## Step 19

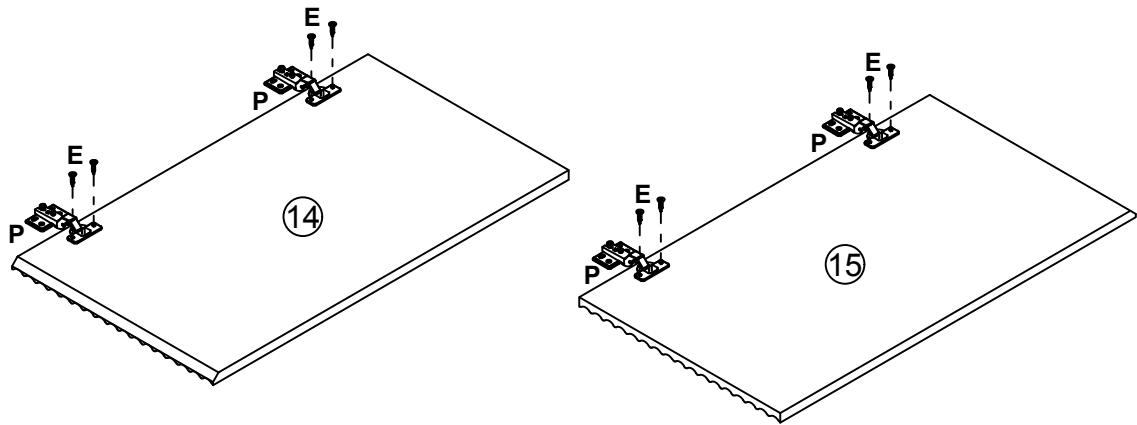

E x 8



P x 4

## Step 20

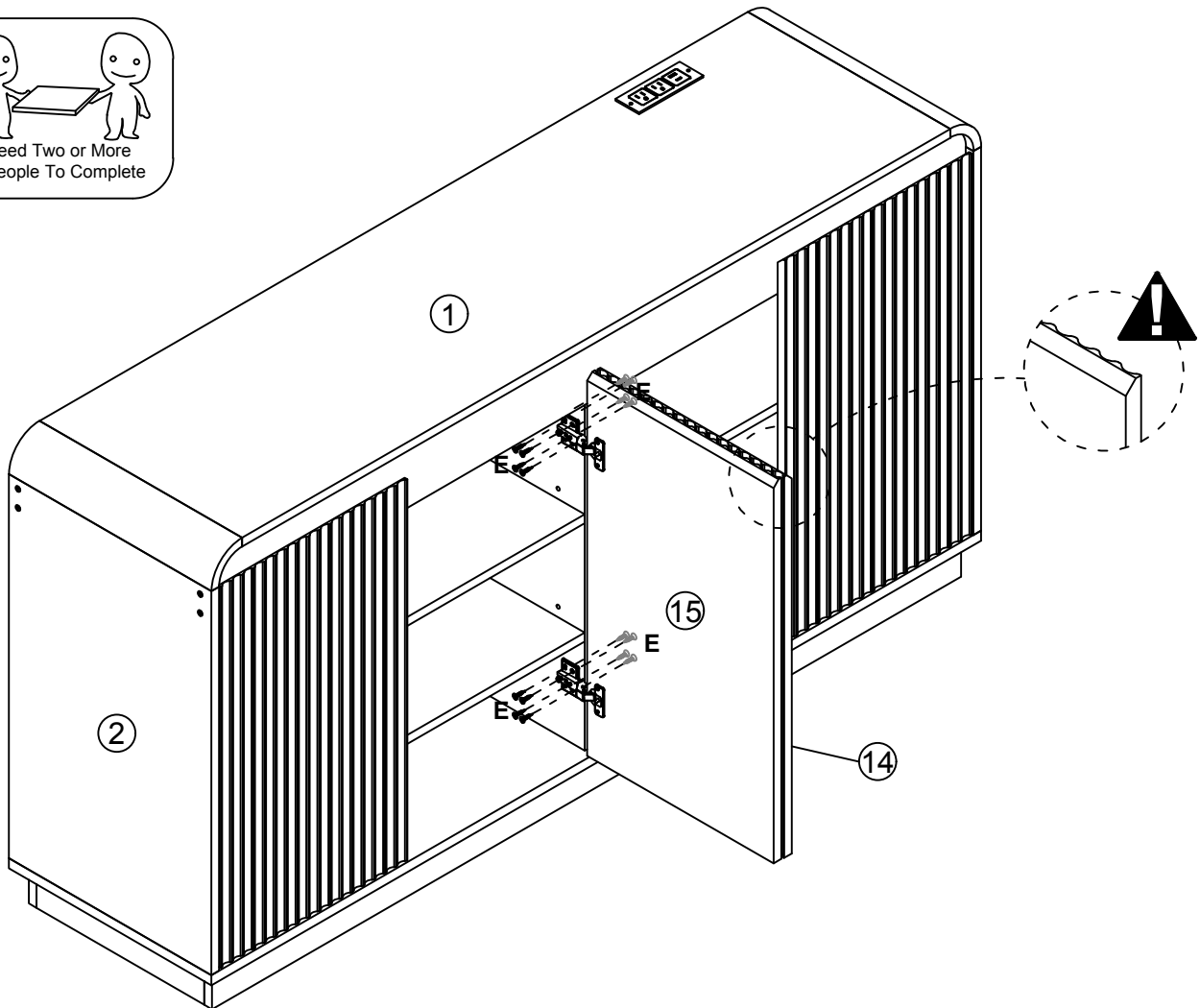
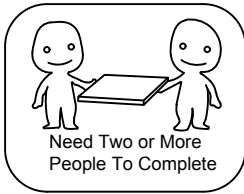

E x 16

## Step 21

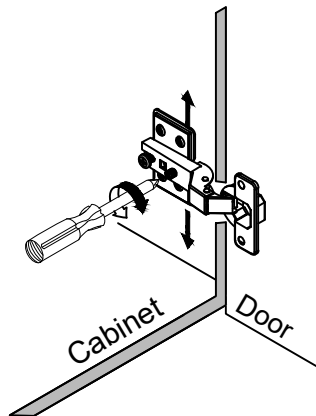
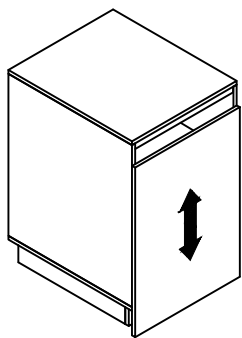
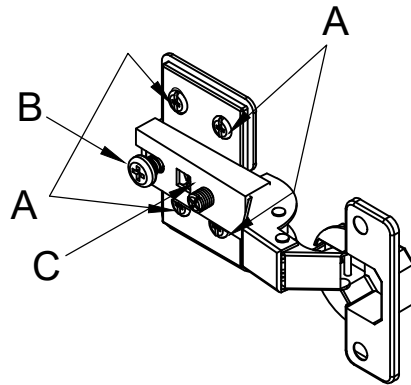

### To adjust the vertical height.

Loosen the four screws "A" on both hinges. Two of them are usually in slotted holes which allows you to adjust up or down by a few mm. Then tighten back up.

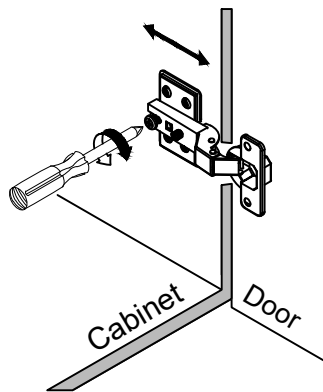
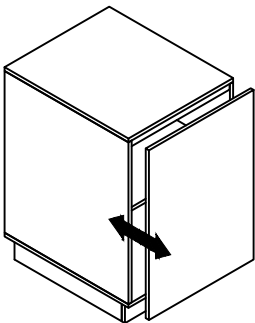

### To adjust depth.

Loosen screw "B" and adjust door, if the door can not be adjusted, please loosen screw "C", then try again. Tighten screw "B" and "C".

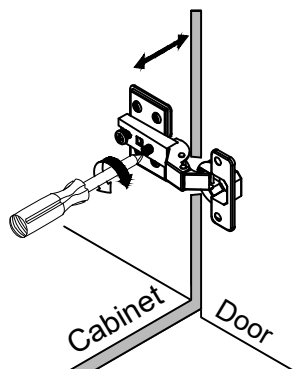
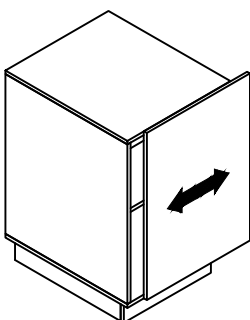

### To adjust side ways.

Turning the screw "C" on BOTH hinges on each door.

# Step 22

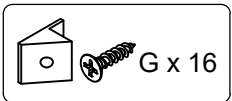
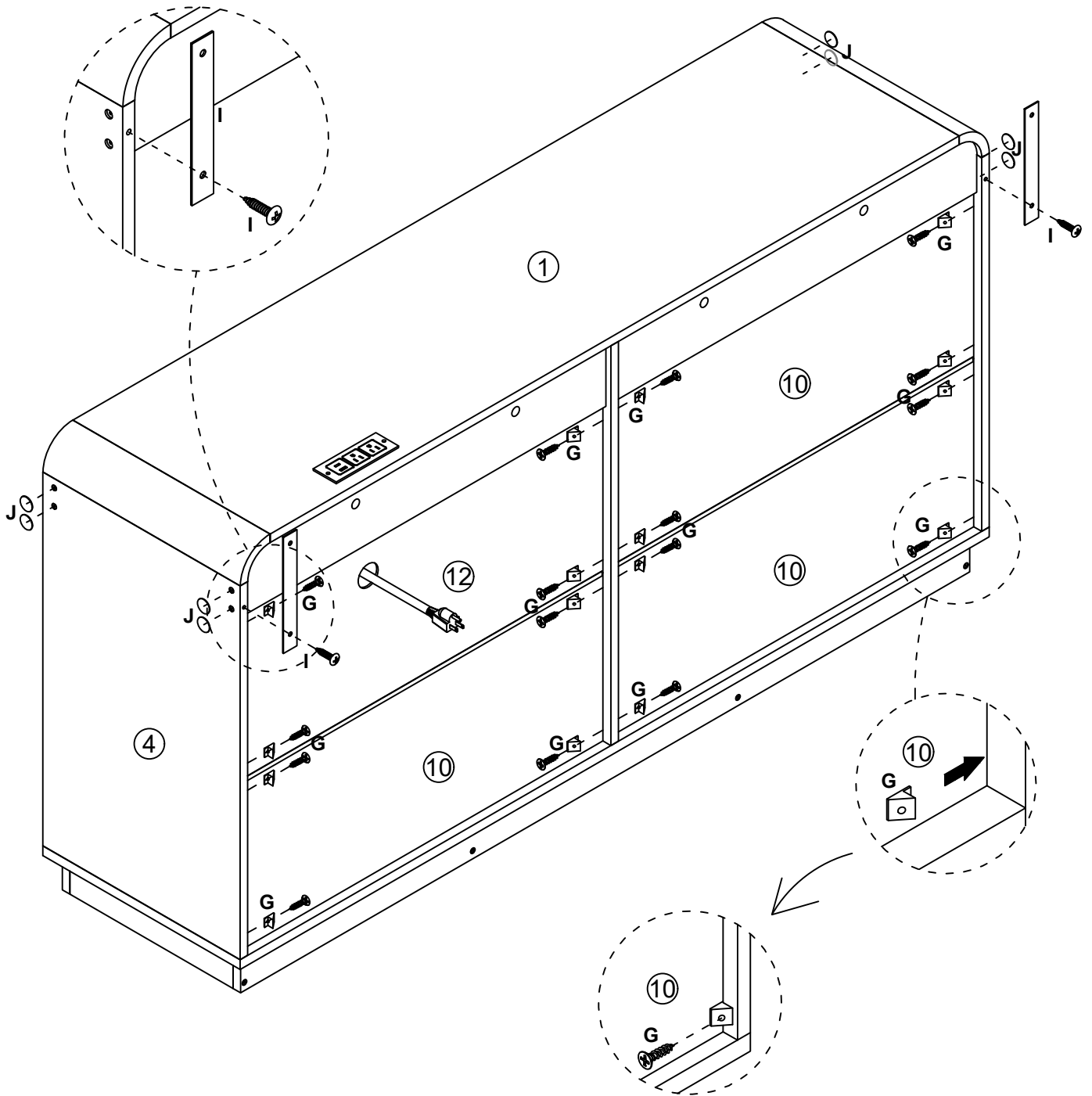

# Step 23

