

INSTALLATION INSTRUCTIONS

For Item No. 1400-01

WARNING! SHUT POWER OFF AT FUSE OR CIRCUIT BREAKER.

Fig. 1

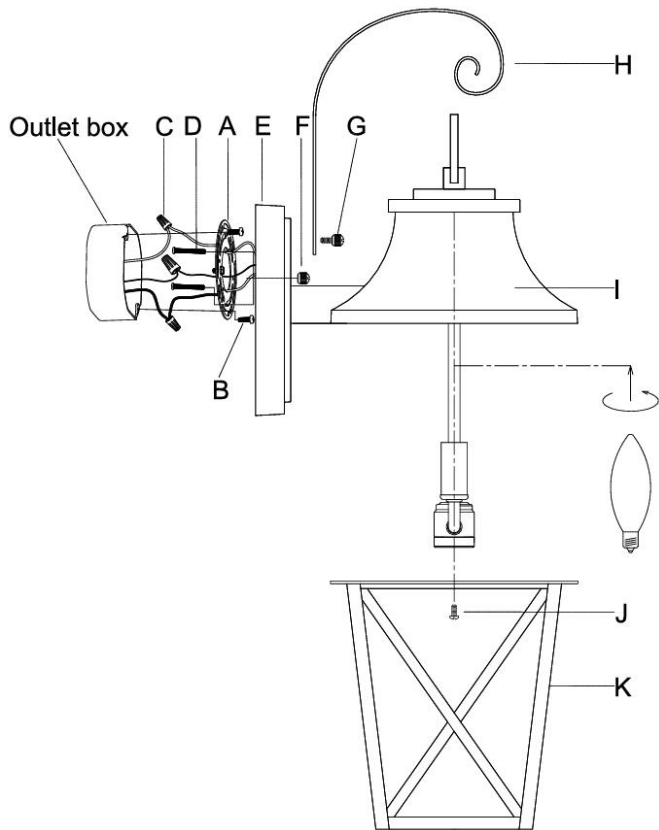

HANGING THE FIXTURE (Fig. 1)

1. Shut off the power at the circuit breaker and remove the old fixture, including the mounting hardware.
2. Carefully unpack your new fixture and lay out all the parts on a clear area. Take care not to lose any small parts necessary for installation.
3. Install the roll (H) to the back plate (E) by locking the screw (G) and let the roll (H) across the loop.
4. Thread the 2 mounting screws (D) into the mounting plate (A) spaced the same distance apart as the holes in the fixture back plate. (You can adjust the length of the screws if necessary.)
5. Attach the mounting plate (A) to the outlet box (not supplied) with mounting screws (B). Ground Wire must face out.

CONNECTING THE WIRES (Fig. 2).

6. Connect the electrical wires as shown in Fig.2. Making sure that all wire connectors are secured. If your outlet box has a ground wire (green or bare copper), connect the fixture's ground wire to it. Otherwise, connect the fixture's ground wire directly to the circular strap using the green screw provided.

COMPLETING THE INSTALLATION (Fig.1)

7. Align the fixture back plate (E) to mounting plate (A) and secure with cap nuts (F).
8. Take off the cage (K) by loosening sets screws (J); install the bulb (E12 Candelabra, not included) in accordance with the fixture's specification. Secure the cage (K) back to the fixture (I) by set screws (J)
9. To prevent moisture from entering the outlet box and causing a short, use clear caulking (i.e. Indoor/Outdoor Silicone Sealant) to outline the outside of fixture back plate where it meets the wall leaving a space at bottom to allow moisture a means to escape. (Fig. 3)

**DO NOT EXCEED THE MAXIMUM WATTAGE RATING!
(NE PAS DEPASSER LA PUISSANCE NOMINALE
MAXIMALE!)**

Your installation is now completed. Return power to the junction box and test the fixture.

Fig. 2

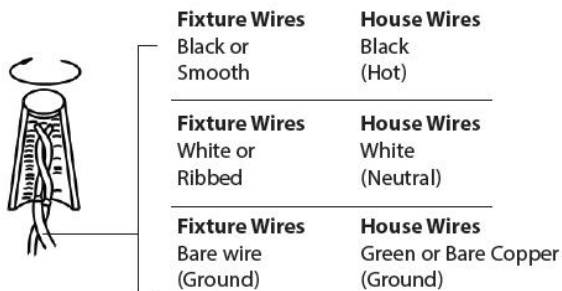
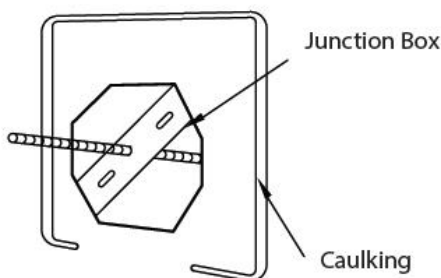

Fig.3 Sealing



This authorizes the application of the Certification Mark(s) shown below to the models described in the Product(s) Covered section when made in accordance with the conditions set forth in the Certification Agreement and Listing Report. This authorization also applies to multiple listee model(s) identified on the correlation page of the Listing Report.

This document is the property of Intertek Testing Services and is not transferable. The certification mark(s) may be applied only at the location of the Party Authorized To Apply Mark.

Applicant:	Foshan Nanhai Grand Lighting Co.,Ltd.	Manufacturer:	Foshan Nanhai Grand Lighting Co., Ltd.
Address:	District C, Shishan Technological and Industrial Zone, Nanhai. Foshan, Guangdong 528226	Address:	District C, Shishan Technological and Industrial Zone, Nanhai. Foshan, Guangdong 528226
Country:	China	Country:	China
Party Authorized To Apply Mark:	Same as Manufacturer		
Report Issuing Office:	Intertek Testing Services (Shanghai FTZ) Co., Ltd		
Control Number:	<u>4004698</u>	Authorized by:	 for L. Matthew Snyder, Certification Manager



This document supersedes all previous Authorizations to Mark for the noted Report Number.

This Authorization to Mark is for the exclusive use of Intertek's Client and is provided pursuant to the Certification agreement between Intertek and its Client. Intertek's responsibility and liability are limited to the terms and conditions of the agreement. Intertek assumes no liability to any party, other than to the Client in accordance with the agreement, for any loss, expense or damage occasioned by the use of this Authorization to Mark. Only the Client is authorized to permit copying or distribution of this Authorization to Mark and then only in its entirety. Use of Intertek's Certification mark is restricted to the conditions laid out in the agreement and in this Authorization to Mark. Any further use of the Intertek name for the sale or advertisement of the tested material, product or service must first be approved in writing by Intertek. Initial Factory Assessments and Follow up Services are for the purpose of assuring appropriate usage of the Certification mark in accordance with the agreement, they are not for the purposes of production quality control and do not relieve the Client of their obligations in this respect.

Intertek Testing Services NA Inc.
545 East Algonquin Road, Arlington Heights, IL 60005
Telephone 800-345-3851 or 847-439-5667 Fax 312-283-1672

Standard(s):	Luminaires [UL 1598:2021 Ed.5+R:31Jan2024]
	Luminaires [CSA C22.2#250.0:2021 Ed.5+U1;U2]
Product:	Fixed Luminaires
Brand Name:	Millennium Lighting

Models:

PHEL4300, PHEL4301, PHEL4302, PHEL4500, PHEL4501, PHEL4502, PHEL4503, PHEL4800, PHEL4801, PHEL4802, PHEL4803, PHEL4805, PHEL5100, PHEL5110, PHEL5101, PHEL5102, PHEL5103, PHEL5200, PHEL5201, PHEL5500, PHEL5501, AC8220, AC8221, AC8230, AC8231, AC8240, AC9140, AC9141, AC9150, PHEL4200, PHEL4201, PHEL4202, PHEL4204, OC901, OC902, OD101, OD102, OD103, OD201, OD202, OD301, OD302, OD303, 44A58, 44A63, 44A59, 44A64, 44A60, 42F98.
8001 or 8002; followed by up to five characters.
V8155, V8335, LC005507, LC005508, LC005509, LC005511, 73341-66, V8156, 8681F, 8682F, 8689F, 8693F, LC005515, LC005516, 19239, 9017384, 2294815.
RALWHS14, RALWHS17, RALWHS20, RWCS13, RWCS17, RCS13, RCS17, RWDBS18, RCLWS14, RCLWS17, RGCS13, 85101, 87101, 85102, 85103, 85105, 86101, 86102, 82101, 88101, 82102, 82103, 82104, 88102, 88103 or 88105 followed by -; followed by up to seven characters.
P81401, V81391, P81051, P81061, RWHCGS17, P560372, P560373, P560374, P560384; maybe followed by -; followed by up to seven characters.
1100-02, 1200-01, 1200-04, 1300-01, 1300-04, 1400-01, 1400-04, 1500-01, 1500-04; followed by up to three characters.