

Assembly Instructions

Caution : You must read this before you proceed

Care & Maintenance



- Not for commercial use. For residential use only.



- Furniture may scratch floors. We recommend using furniture pads to protect your floors.



- Do not put hot items directly on furniture surface.



- Do not clean furniture with harsh cleansers or polish.



- Do not place furniture under direct sunlight.



- Do not place furniture near heating or cooling vents.



- Do not write on furniture without a padded barrier to protect the surface.



- Do not place furniture outside . For indoor use only.



- Stains may be removed with mild soap solution and damp cloth.



- Children should not climb or jump on the furniture.



- Dust and pick-up spills using a clean, non-colored, lint-free cloth.



Please look in Chair for hardware packs and legs.

Sets often ship in multiple boxes and may arrive a day or two apart.

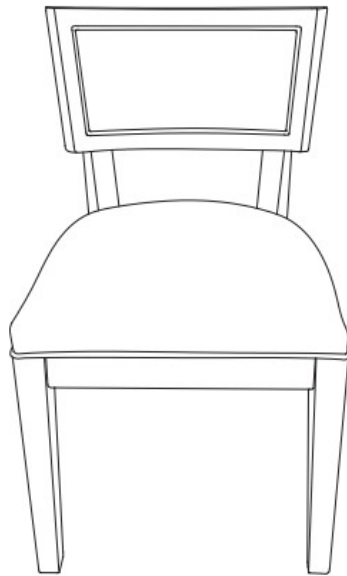

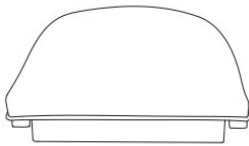
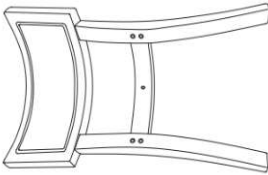

Chair



Parts List

Label	Picture	Description	QTY
A		Seat	1
B		Back with Legs	1
C		Front Legs	2

Hardware

Label	Picture	Description	QTY
①		Bolt (M8*60MM)	10
②		Spring Washer	10
③		Washer	10
④		Allen Wrench	1

Assembly Preparation

Before Beginning Assembly:

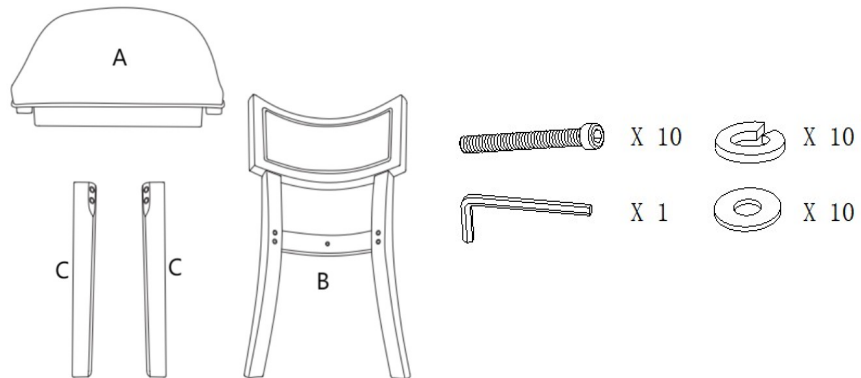

- Read instructions, cover to cover-



- Have 2 adults on hand for assembly-



- Do not assemble on flooring or carpet-



- Assemble on a clean non-marring surface (packing foam)-



- Save all packaging until finished-

Assembly Steps

Overview

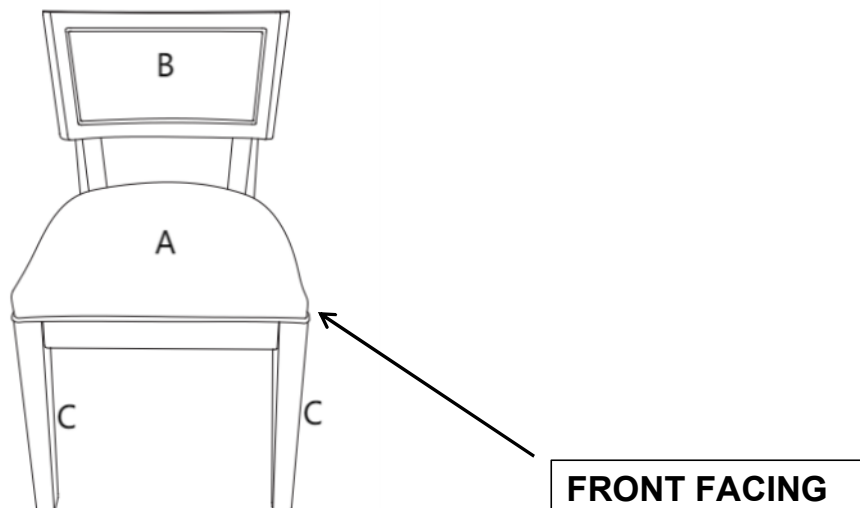

This Chair has multiple parts and may require up to 30 minutes to assemble. To give you an overview of the Chair parts, the above picture is to help you put the various parts into perspective. Please read through the instructions below to familiarise yourself with the parts and steps before assembly.

Step 1

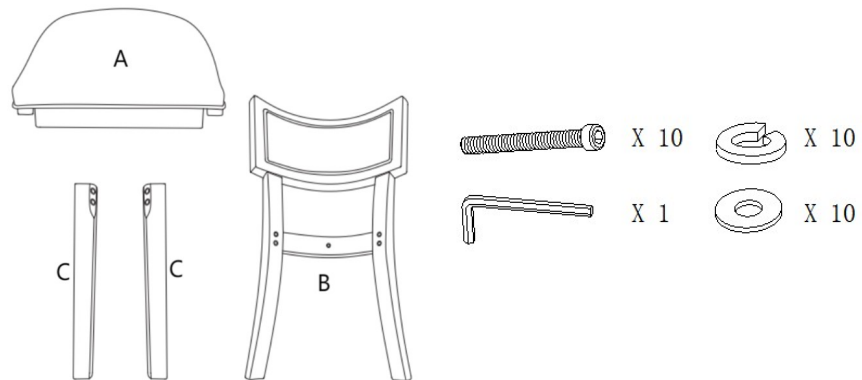

Unpack and place all parts on a clean, non-marring surface.

Step 2

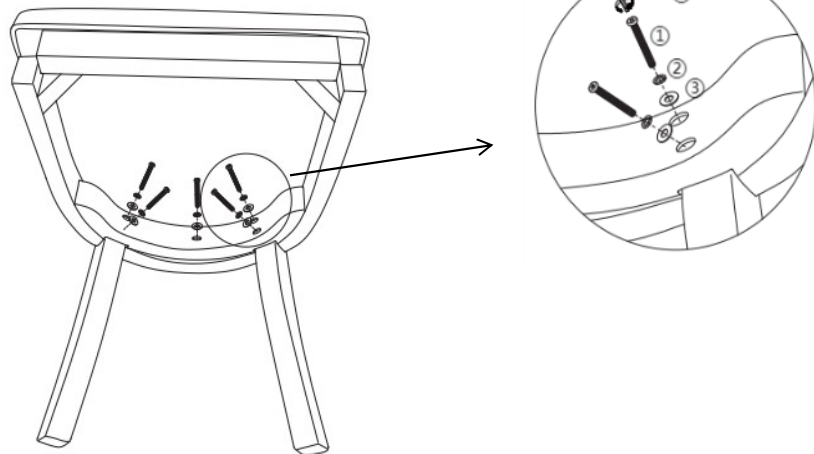

Place the Back with Legs(B) on a clean, non-marring surface.
Align the mounting positions on the Seat(A) to the mountings on the Back with Legs(B).
Lock the middle mounting position first, by using Bolts(①), Spring Washers(②) and Washers(③) with Allen Key(④).
Then lock the corner four mounting positions and attach them using Bolts(①), Spring Washers(②) and Washers(③) with Allen Wrench(④), as shown on the picture above.
Do not fully tighten the Bolts.

Step 3

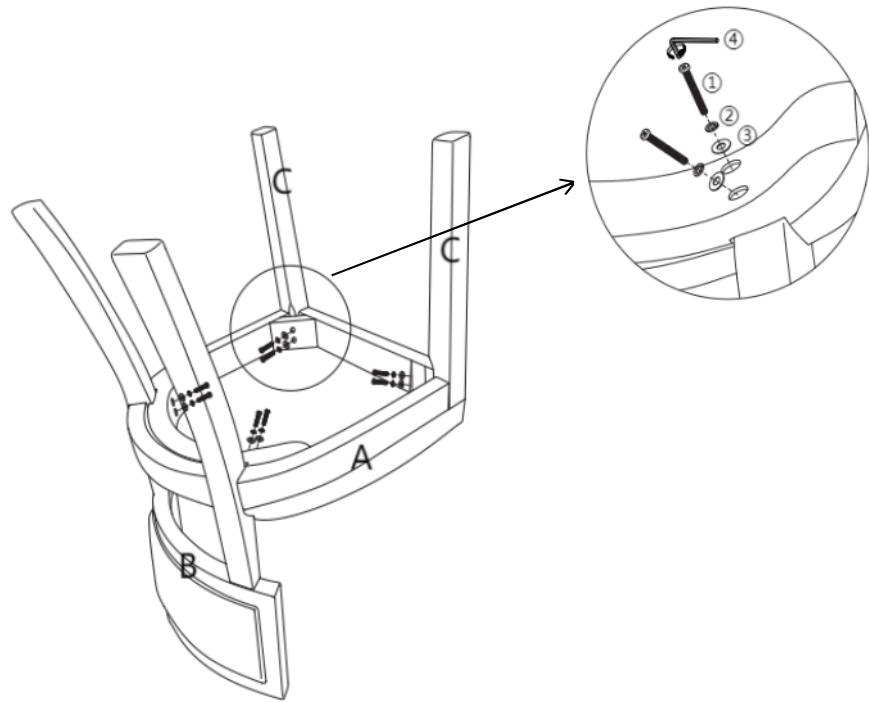

Place the Pack of Seat(A) and Back with legs(B) on the side of a table with the Seat(A) facing down, as seen in the picture.
Insert Front Leg(C) into the mounting position of Seat(A) and attach using Bolts(①), Spring Washers(②) and Washers(③) with Allen Wrench(④).
Do not fully tighten the Bolts.

Step 4

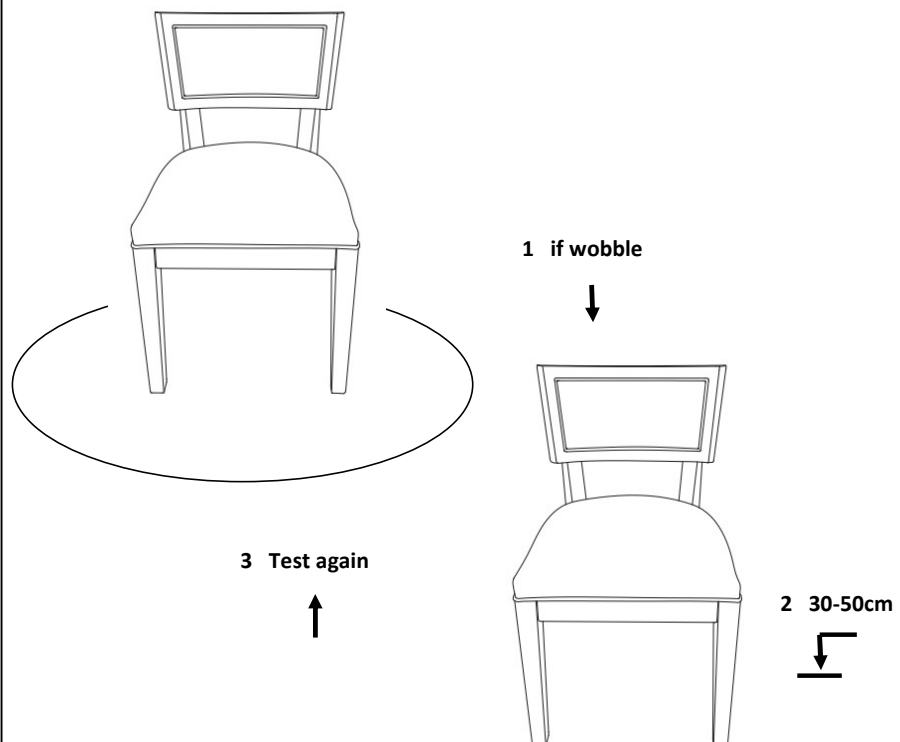

Place the Chair on a level Surface to check if it wobbles.
If it wobbles, lift the Chair some 30cm to 50cm above the ground.
Keep your feet and toes well away from the drop zone.
Drop chair freely and vertically, with the four legs hitting the ground at the same time.
This Drop Test will help to ensure that all the Bolts and gaps reach full alignment status.
Test again for evenness on a Level Surface.
If no wobbles are found, proceed to tighten all the Bolts.
When tightening the Bolts, tighten sequentially.
Do not fully tighten any bolt fully and then move towards the next one.
This may cause the frame to warp.
If there are still wobbles after tightening, loosen the Bolts and execute this same drop test.

Step 5

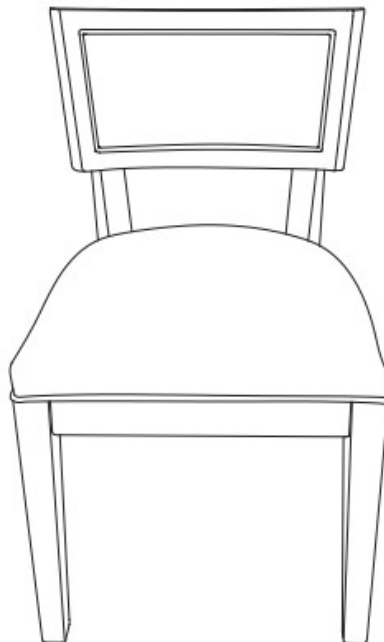

Stand the Chair up.
Your Chair is ready for use.
This Chair can only be used on a flat, level surface.