

TRA-0424

WOOD CHIPPER



Video on Youtube



Service information,
Customer Support (888)680-2849,
inquiry@bilthardusa.com



Operator's Manual

BILT HARD

BILT HARD

WARNING

- ▲ Any changes by the operators or dealers at their own are forbidden.
 - ▲ Any other purposes except WOOD CHIPPER are not allowed.
 - ▲ Please read the owner's manual carefully and make sure you understand the instructions before using the machine.
 - ▲ Any damages or injuries caused by disobeying the above terms, our company will be free from any responsibilities and warranty services for this machine will be terminated accordingly.
-

Table of Contents

TABLE OF CONTENTS.....	1
SPECIFICATIONS.....	2
OVERALL DIMENSIONS.....	2
SAFETY SIGNS.....	2
SAFETY.....	2
Propose.....	4
Before Using theWood Chipper.....	4
Protecting Yourself and Those Around You.....	4
Safety For Children and Pets.....	5
Safety Wih Gasoline-Powered Machines.....	5
General Safety.....	6
UNPACKING THE CONTAINER.....	8
CONTENTS SUPPLIED.....	9
ASSEMBLY.....	10
PRECAUTIONS FOR STARTING THE MACHINE.....	13
KNOW YOUR MACHINE.....	15
MAINTANING THE WOOD CHIPPER.....	16
Troubleshooting Table.....	17
EXPLOSION VIEW AND PARTS LST.....	18

SPECIFICATIONS

Model	TRA-0424
Engine	B&S VANGUARD 14HP 25V337F
Engine Type	ELECTRIC START AIR COOLED 4 STROKE PETROL ENGINE:
Displacement/HP	408cc;14HP
Engine Bore	3.465 in (88 mm)
Engine Stroke	2.638 in (67 mm)
Fuel capacity	194.12 oz (5.74 L)
Engine Oil capacity	28 - 32 oz (,83 - ,95 L)
Battery	12V 18Ah 10Hr
Belt	2 x V-Belts
Belt Brand	Sanlux
Clutch	Centrifugal Clutch
Cutting Method	Drum
Max. Chipping Dia.	6 Inch
Knives Nos.	2 x Blade; 1 xAnvil
Discharge chute	360 Degree Rotating
Emergency stop	STOP BAR
Towing	TOW BAR With 2 INCH Hitch Ball
Wheel	16x8.0-7/4.10-4
Package Method	Plywood Case
Weight (N. W./ G. W.)	562 /628 LB
Packing Size (L*w*h)	45.2X31X49.6 inch
Machine warranty	1 Years
Engine warranty	1 Years

OVERALL DIMENSIONS

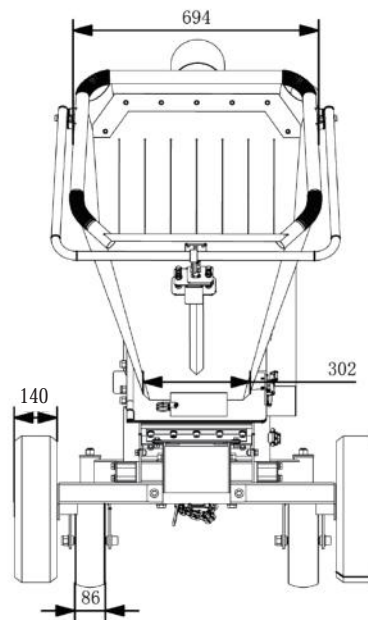
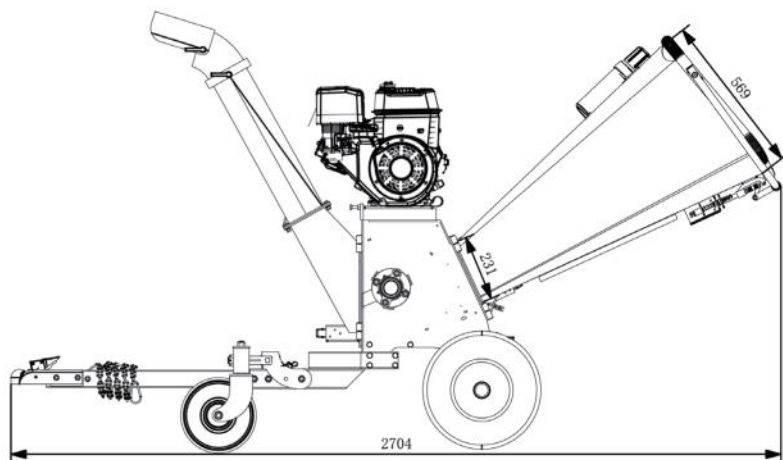

SAFETY SIGNS

The rating plate on your machine may show symbols. These represent important information about the product or instructions on its use.

⚠ WARNING

⚠ WARNING

DO NOT place wood or branch over 150mm diameter into the shredder hopper. The blades may be stuck if feed wood or branch bigger than 150mm diameter.

• Read the owner's manual(s) before starting and using unit.

• Keep all shields and guards in place and securely attached.

• Keep hands feet back, clothing and long hair out of shredder hopper, chopper, chute and discharge chute while the engine is running.

• Rotating cutting blades inside these openings will cause serious personal injury if contacted. Material being processed may bounce back from end opening or be blown from the discharge chute. Long hair or loose clothing may be pulled inside into the reel openings.

• All the shipped shredder joints or become clogged. Immediately shut off the engine and wait for all moving parts to come to a complete stop before clearing.

• If engine stalls because of jammed blades, control lever to stop position or shut off valve to "0" if equipped before clearing.

• All oil and leaks, remove oil and/or service the discharge screen or any other part while the engine is running. Blade contact can occur. Do not operate on uneven ground where unit is unstable.

• To avoid the hazard, keep leaves, grass, and other combustible materials away from hot engine and muffler.

• Keep children and others away from area of operation.

• Wear approved safety glasses, gloves and ear protection.

• Do not operate on pavement, gravel or other hard surfaces since objects can ricochet and cause injury.

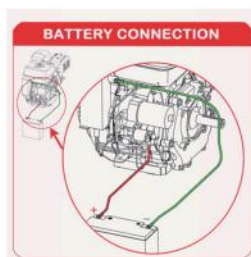

⚠ DANGER

⚠ WARNING



STOP The engine is shipped without oil. Do not start the engine before adding oil.

OIL RECOMMENDATION

engine oil capacity(1100ML)

SAFETY

Propose

This machine is designed solely to chip wood and must not be used for any other purpose.

It should only be used by trained operators who are familiar with the content of this manual. It is potentially hazardous to fit or use any parts other than your dealer parts. The company disclaims all liability for the consequences of such use, which in addition voids the machine warranty

Before using the wood chipper

- A. Operators must be fully trained before using this machine...
- B. User Manual is read and understood.
- C. Machine is positioned on level ground, all guards are fitted and in good condition.
- D. Blades are in good condition and secure. All blades are sharpened or replaced in sets
- E. All fasteners are checked for tightness.
- F. Only WOODEN materials free of nails etc. are fed into the machine.
- G. Emergency stop wire is rightly connected and the switch is functional.
- H. Fire extinguisher is available on site.

When Using The Wood Chipper

- A. Always feed from the side.
- B. It is better to have a second trained operator within easy reach of the machine.
- C. Maintain strict discipline at all times and service machine at specified periods.
- D. Note direction of discharge chute and if necessary note the wind direction to prevent debris from being blown into highway or where it could affect members of the public.
- E. DO NOT put any part of your body into the in-feed chute while the machine is running.
- F. DO NOT operate the machine whilst under the influence of alcohol or drugs.
- G. DO NOT operate inside a building or confined space or Climb on the in-feed chute.

Protecting Yourself and Those Around You

This is a high-powered machine, with moving parts operating with high energy. You must operate the machine safely. Unsafe operation can create a number of hazards for you, as well as anyone else in the nearby area. Always take the following precautions when using this machine:

- A. Keep in mind that the operator or user is responsible for accidents or hazards occurring to other people, their property, and themselves.
- B. Always wear protective goggles or safety glasses with side shields while using the Wood Chipper to protect your eyes from possible thrown debris.
- C. Avoid wearing loose clothing or jewelry, which can catch on moving parts.
- D. We recommend wearing gloves while using the Wood Chipper. Be sure your gloves fit properly and do not have loose cuffs or drawstrings.
- E. Wear shoes with non-slip treads when using your Wood Chipper. If you have safety shoes, we recommend wearing them. Do not use the machine while barefoot or wearing open sandals.
- F. Wear long pants while operating the Wood Chipper.
- G. Keep bystanders at least 50 feet away from your work area at all times. Stop the engine when another person or pet approaches

Safety for Children and Pets

Tragic accidents can occur if the operator is not alert to the presence of children and pets. Children are often attracted to the machine and the chipping activity. Never assume that children will remain where you last saw them.

Always follow these precautions:

- A. Keep children and pets at least 50 feet from the working area and ensure they are under the watchful care of a responsible adult.
- B. Be alert and turn the machine off if children or pets enter the work area.
- C. Never allow children to operate the Wood Chipper.

Safety with Gasoline - Powered Machines

Gasoline is a highly flammable liquid. Gasoline also gives off flammable vapor that can be easily ignited and cause a fire or explosion. Never overlook the hazards of gasoline. Always follow these precautions:

- A. Never run the engine in an enclosed area or without proper ventilation as the exhaust from the engine contains carbon monoxide, which is an odorless, tasteless, and a deadly poisonous gas.
- B. Store all fuel and oil in containers specifically designed and approved for this purpose and keep away from heat and open flame, and out of the reach of children.
- C. Replace rubber fuel lines and grommets when worn or damaged and after 5 years of use.
- D. Fill the gasoline tank outdoors with the engine off and allow the engine to cool completely. Don't handle

gasoline if you or anyone nearby is smoking, or if you're near anything that could cause it to ignite or explode.

Reinstall the fuel tank cap and fuel container cap securely.

E.If you spill gasoline, do not attempt to start the engine. Move the machine away from the area of the spill and avoid creating any source of ignition until the gas vapors have dissipated. Wipe up any spilled fuel to prevent a fire hazard and properly dispose of the waste.

F.Allow the engine to cool completely before storing in any enclosure. Never store a machine that has gas in the tank, or a fuel container, near an open flame or spark such as a water heater, space heater, clothes dryer or furnace.

G.Never make adjustments or repairs with the engine running. Shut down the engine, disconnect the spark plug wire, keeping it away from the spark plug to prevent accidental starting, wait 5 minutes before making adjustments or repairs.

H.Never tamper with the engine's governor setting. The governor controls the maximum safe operation speed and protects the engine. Over-speeding the engine is dangerous and will cause damage to the engine and to the other moving parts of the machine. If required, see your authorized dealer for engine governor adjustments.

I.Keep combustible substances away from the engine when it is hot.

J.Never cover the machine while the muffler is still hot.

K.Do not operate the engine with the air cleaner or the carburetor air intake cover removed. Removal of such parts could create a fire hazard. Do not use flammable solutions to clean the air filter.

L.The muffler and engine become very hot and can cause a severe burn; do not touch

General Safety.

Operating this Wood Chipper safely is necessary to prevent or minimize the risk of death or serious injury. Unsafe operation can create a number of hazards for you. Always take the following precautions when operating:

A.Your Wood Chipper is a powerful tool, not a plaything. Exercise extreme caution at all times. The machine is designed to Chip Woods. Do not use it for any other purpose.

B.Know how to stop the Wood Chipper quickly.

C.Never operate your unit on a slippery, wet, muddy, or icy surface. Exercise caution to avoid slipping or falling.

D.See manufacturer's instructions for proper operation and installation of accessories.

E.Never use the machine without ensuring that all guards and shields are in place.

F.Never, under any conditions, remove, bend, cut, fit, weld, or otherwise alter standard parts on the Wood Chipper. This includes all shields and guards. Modifications to your machine could cause personal injuries and property damage and will invalidate your warranty.

G.If the machine start to make an unusual noise or vibrate, shut down the engine, disconnect the spark plug wire, .

keeping it away from the spark plug to prevent accidental starting, wait 5 minutes for engine to cool down, then inspect for damage. Vibration is generally a warning of trouble. Check damaged parts and clean, repair and/or replace as necessary.

H.Never tamper with safety devices. Check their proper operation regularly.

I.Before performing any maintenance or inspection procedure, shut down the engine, disconnect the spark plug wire keeping it away from the spark plug to prevent accidental starting, wait 5 minutes for machine to cool down.

J.Never allow people who are unfamiliar with these instructions to use the Wood Chipper. Allow only responsible individuals who are familiar with these rules of safe operation to use your machine.

K.Never overload or attempt to chip woods beyond the manufacturer's recommendation. It could result in personal injury or damage to the machine.

L.While using, don't hurry or take things for granted. When in doubt about the equipment or your surroundings stop the machine and take time to look things over.

M.Never operate the machine when under the influence of alcohol, drugs, or medication.

N.Use the machine only in daylight.

O.Stay alert for hidden hazards or traffic.

P.Keep all nuts and bolts tight and keep the equipment in good operating condition., keeping it away from the spark plug to prevent accidental starting, wait 5 minutes for engine to cool down, then inspect for damage. Vibration is generally a warning of trouble. Check damaged parts and clean, repair and/or replace as necessary.

H.Never tamper with safety devices. Check their proper operation regularly.

I.Before performing any maintenance or inspection procedure, shut down the engine, disconnect the spark plug wire keeping it away from the spark plug to prevent accidental starting, wait 5 minutes for machine to cool down.

J.Never allow people who are unfamiliar with these instructions to use the Wood Chipper. Allow only responsible individuals who are familiar with these rules of safe operation to use your machine.

K.Never overload or attempt to chip woods beyond the manufacturer's recommendation. It could result in personal injury or damage to the machine.

L.While using, don't hurry or take things for granted. When in doubt about the equipment or your surroundings stop the machine and take time to look things over.

M.Never operate the machine when under the influence of alcohol, drugs, or medication.

N.Use the machine only in daylight.

O.Stay alert for hidden hazards or traffic.

P.Keep all nuts and bolts tight and keep the equipment in good operating condition

UNPACKING THE CONTAINER

Use the screwdriver and hammer to open all the side locks.

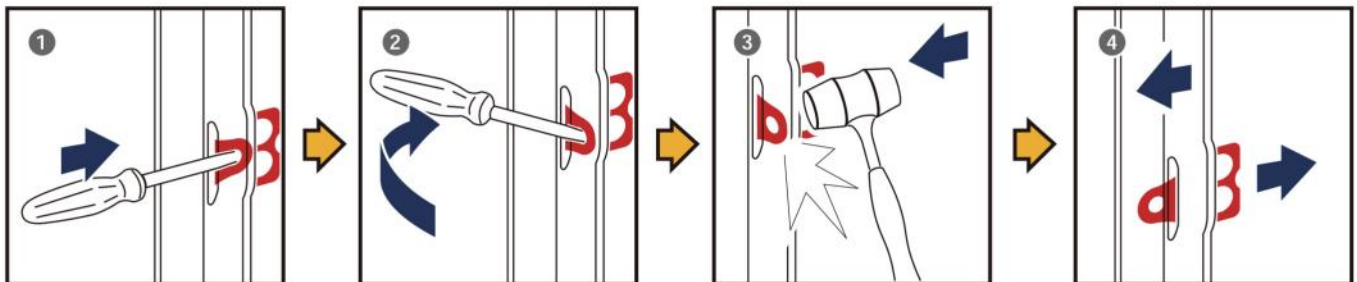
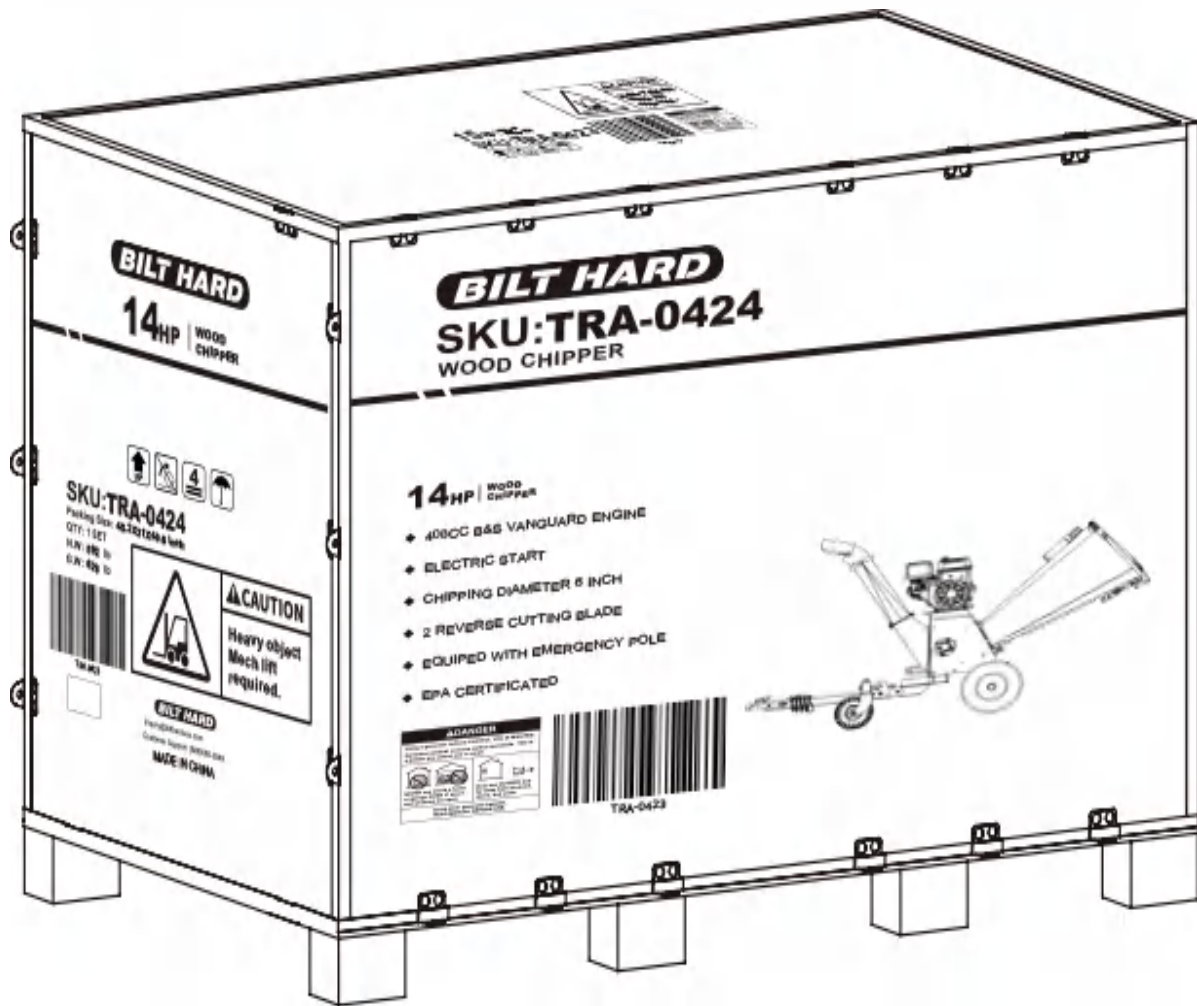

CONTENTS SUPPLIED

Your Wood chipper comes partially assembled and contains the following:

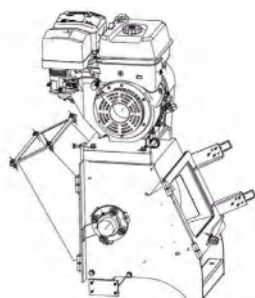

1x Engine and base frame



1x Rear Axle

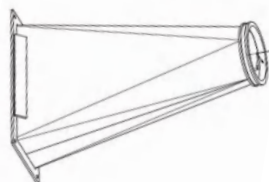

1x Lower discharging chute

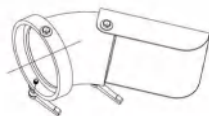

1x 360 degree upper expulsion chute

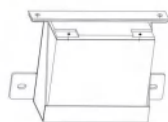

1x Battery

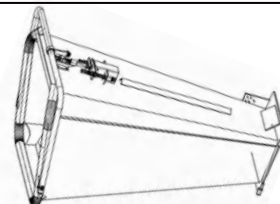

1x Infeed chute

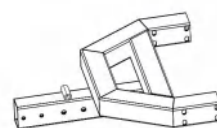

1x Tower bar mount



1x Towbar 2x Guiding wheel

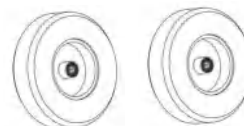

2x Wheels



1x Axle

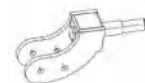

1x Front Fork

1. Wheels

Thread the 2 wheels on the rear axle, 2 pcs Plain washer $\varnothing 26 \times \varnothing 40$, 2 pcs Slotted nut M24x1.5, 2 pcs Split pin 3x50, 2 pcs Dust cover $\varnothing 47$ (See Figure 1).

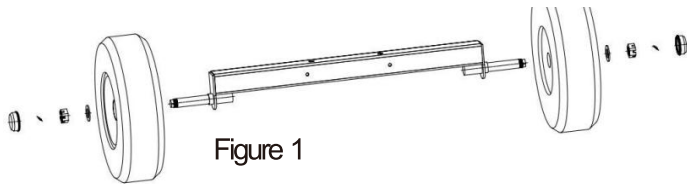

- 2 pcs Plain washer $\varnothing 26 \times \varnothing 40$
- 2 pcs Slotted nut M24x1.5
- 2 pcs Split pin 3x50
- 2 pcs Dust cover $\varnothing 47$

2. Rear Axle

Mount the rear axle with wheels under the frame, 2 pcs Hex head bolt M14x145, 4 pcs Plain washer 14, 2 pcs Standard spring washer 14, 2 pcs Hexagon nut. (See Figure 2).

Figure 2

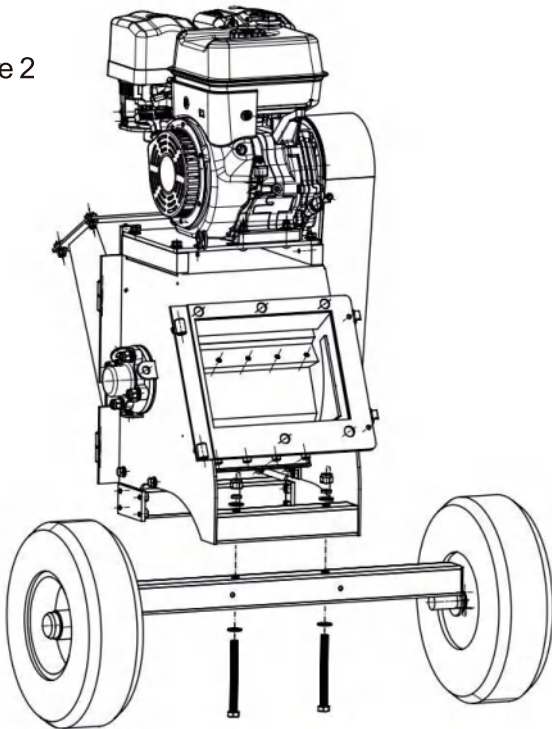

- 2 pcs Hex head bolt M14x145
- 4 pcs Plain washer 14
- 2 pcs Standard spring washer 14
- 2 pcs Hexagon nut

3. Infeed chute

Attach the Infeed Chute, First, install the hinges and Then, install the 2 pcs Hex head bolt M10x85, 2 pcs Plain washer 10, 2 pcs Standard spring washer 10, 2 pcs Hexagon nut (See Figure 3).

Figure 3

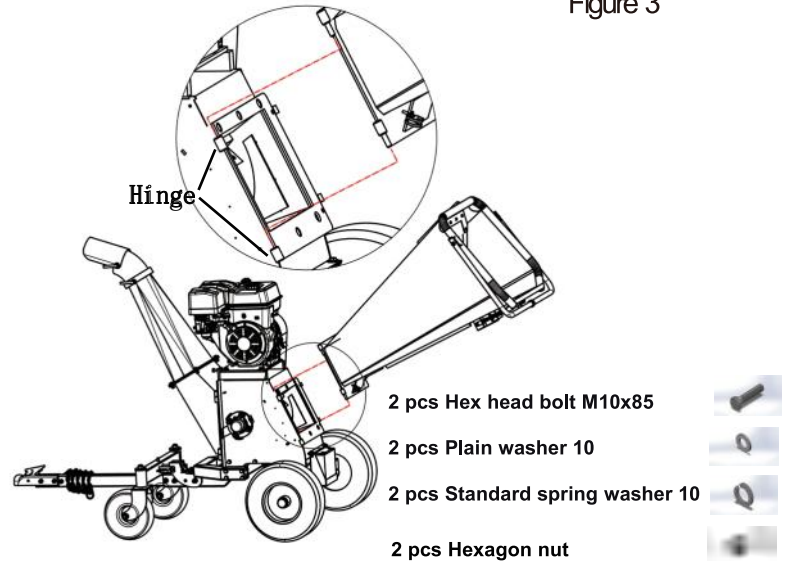

- 2 pcs Hex head bolt M10x85
- 2 pcs Plain washer 10
- 2 pcs Standard spring washer 10
- 2 pcs Hexagon nut

4. Tower bar mount

Mount the Tower bar mount the frame using 8 pcs Hex head bolt M10x85, 8 pcs Plain washer 10, 8 pcs Standard spring washer 10, 8 pcs Hexagon nut. (See Figure 4).

Figure 4

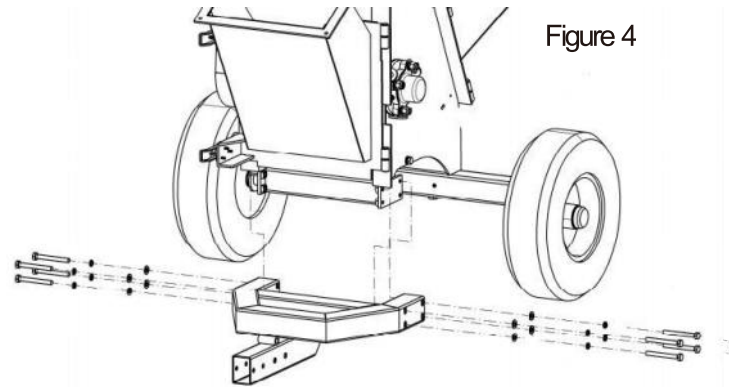





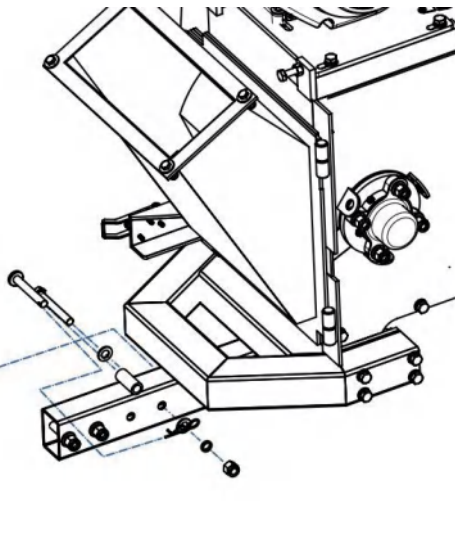

- 8 pcs Hex head bolt M10x85
- 8 pcs Plain washer 10
- 8 pcs Standard spring washer 10
- 8 pcs Hexagon nut

5. Front Fork

Attach the Front Fork to the bar mount using 1 pcs Hex head bolt M12x90, 1 pcs Plain washer 12, 1 pcs Standard spring washer 12, 1 pcs Hexagon nut, 1 pcs Pin shaft, 1 pcs Type B pin 3x30 (See Figure 5).

Figure 5





-  1 pcs Hex head bolt M12x90
-  1 pcs Plain washer 12
-  1 pcs Standard spring washer 12
-  1 pcs Hexagon nut, style 1 with non-metallic insert M12
-  1 pcs Pin shaft
-  1 pcs Type B pin 3x30

7. Axle With Guide Wheel

Install the main bracket on the front wheel mount using 1 pc Slotted nut M24x1.5, 1 pc Split pin 3x50, 2 pcs Hex head bolt M10x60, 2 pcs Hexagon nut (See Figure 7).

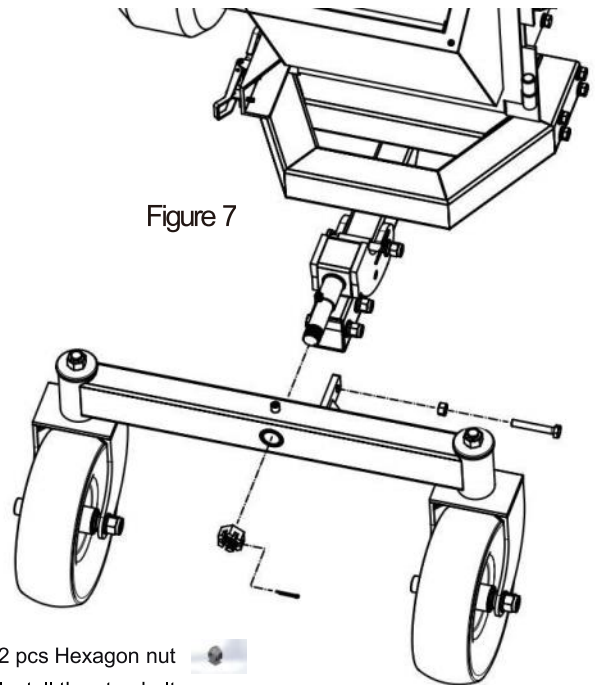
Figure 7



-  2 pcs Hexagon nut
- Install the stop bolt
-  2 pcs Hex head bolt M10x60
-  2 pcs Hexagon nut, style 1 with non-metallic insert M10

6. Guide Wheel

Attach the guide wheels to the wheel axles using 2 pcs Hexagon nut. (See Figure 6).

Figure 6

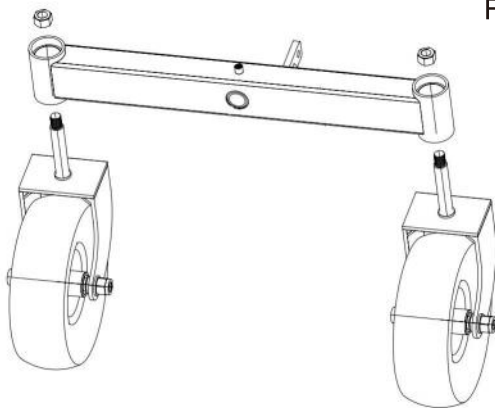





-  2 pcs Hexagon nut

8. Lower discharging chute

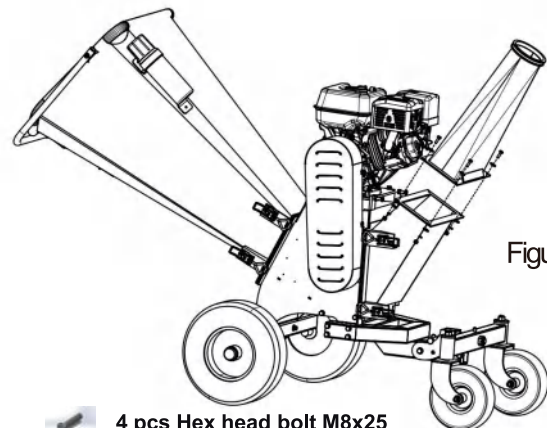
Install the Lower section of the discharge hopper
Using 4 pcs Hex head bolt M8x25, 4 pcs Plain washer 8, 4 pcs Standard spring washer 8, 4 pcs Hexagon nut (See Figure 8).

Figure 8



-  4 pcs Hex head bolt M8x25
-  4 pcs Plain washer 8
-  4 pcs Standard spring washer 8
-  4 pcs Hexagon nut, style 1 with non-metallic insert M8

9. 360 degree upper expulsion chute

Install the upper discharge hopper and guide cover onto the middle discharge hopper section, 1 pc Plastic handle quick-release bolt, 2 pcs Plain washer 8, 1 pc Standard spring washer 8, 1 pc Hex head bolt M8x20 (See Figure 9).

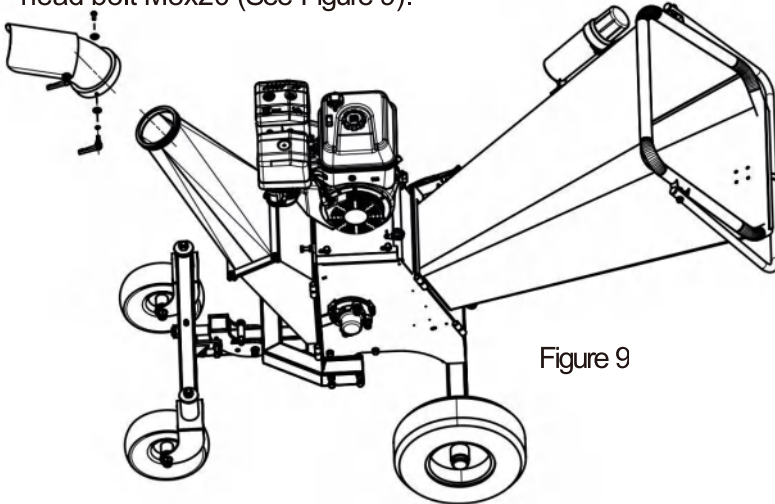





Figure 9

-  1 pc Plastic handle quick-release bolt
-  2 pcs Plain washer 8
-  1 pc Standard spring washer 8
-  1 pc Hex head bolt M8x20

10. Tow Bar

Attach the tow bar to the axles using 2 pcs Hex head bolt M12x70, 2 pcs Plain washer 12, 2 pcs Standard spring washer 12, 2 pcs Hexagon nut, style 1 with non-metallic insert M12. (See Figure 10).

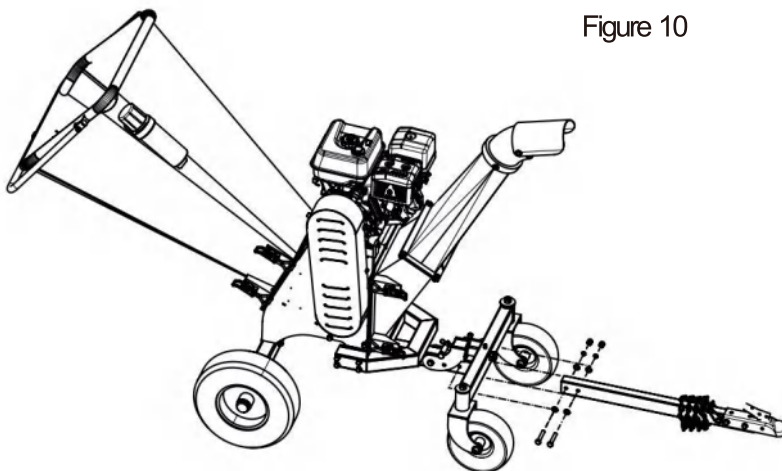





Figure 10





-  2 pcs Hex head bolt M12x70
-  2 pcs Plain washer 12
-  2 pcs Standard spring washer 12
-  2 pcs Hexagon nut, style 1 with non-metallic insert M12

11. Battery

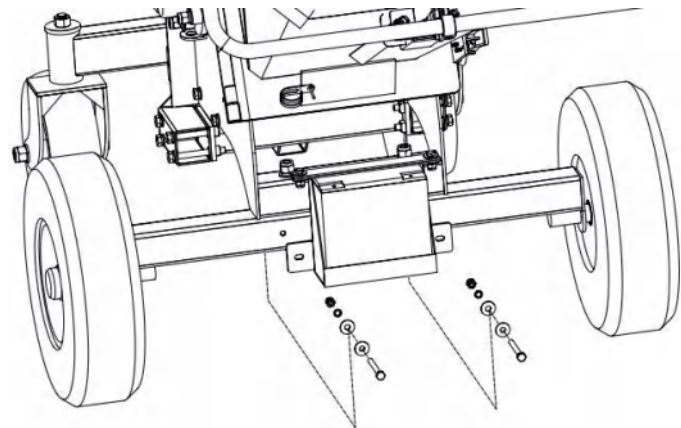
Attach the battery to the wheel axles using 2 pcs Hexhead bolt M8x80, 4 pcs Plain washer 8, 2 pcs Standardspring washer 8, 2 pcs Hexagon nut, style 1 with non-metallic insert M8, Connect the battery cables: red to the positive terminal and green to the negative terminal (See Figure 11).

Figure 11



-  2 pcs Hex head bolt M8x80
-  4 pcs Plain washer 8
-  2 pcs Standard spring washer 8
-  2 pcs Hexagon nut

12. Connect Wires

The Emergency Stop wiring is located near the engine. Simply connect the wires as required. The emergency stop, the feed barrel limit switch, and the discharge barrel limit switch are connected in parallel and then connected to the engine. (See Figure 12)

Figure 12

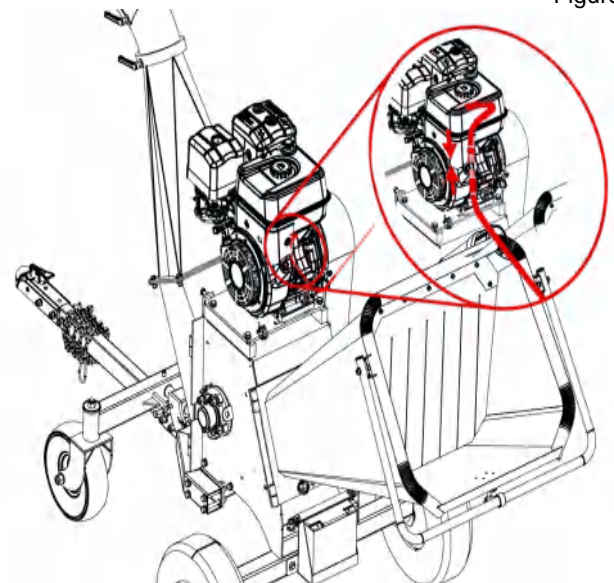

Precautions for starting the machine

The following is for reference only: the machine startup process and stoppage

0. Before starting, confirm the emergency stop lever is in the position shown in picture.

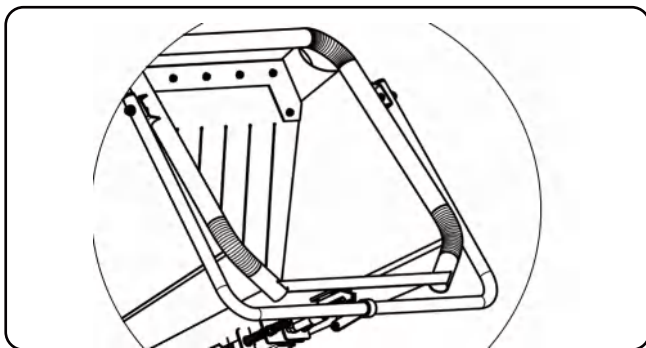

1. Unscrew the dipstick from the oil filler neck, add an appropriate amount of oil. The standard for proper oil level is that when the dipstick is reinserted, the oil should immerse between the lower mark and upper mark on the dipstick. After adding the oil, screw the dipstick back into place.

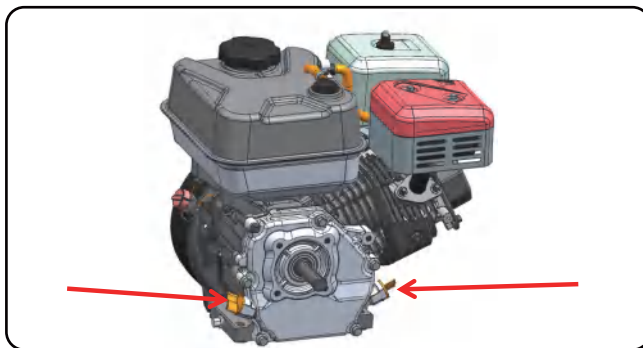

2. Unscrew the gasoline cap, add an appropriate amount of gasoline and rotate the gasoline cap after filling

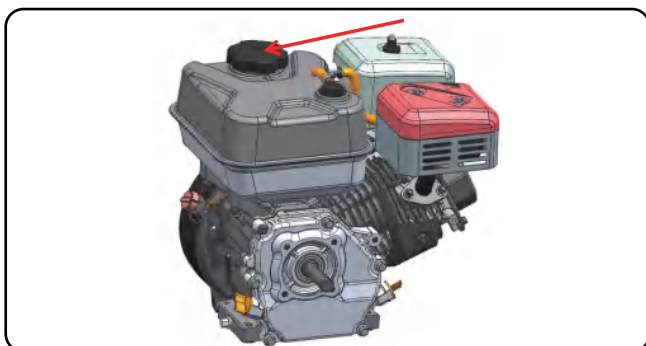

3. Turn on the throttle switch on the carburetor (dial to the right)



4. Turn on the ignition switch (the switch is turned on to the ON position)

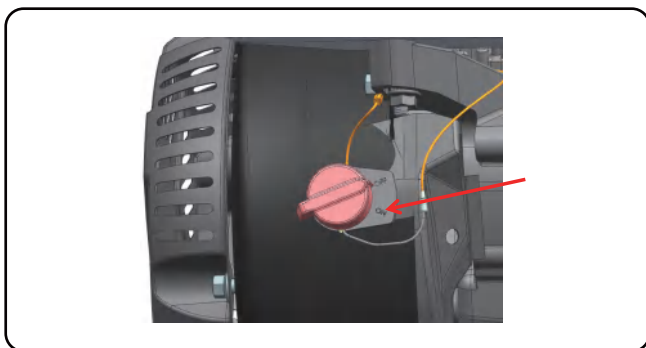

5. Close the choke on the carburetor (dial left)



6. recoil start pull the recoil starter rope



7. Electric Start: Turn on the electric starter switch to the start position.



8. Open the choke (Pull it to the right) 1-2 seconds after starting.



10. If the machine is to be stopped for a long time turn off the kill switch (switch is turned to the OFF position)

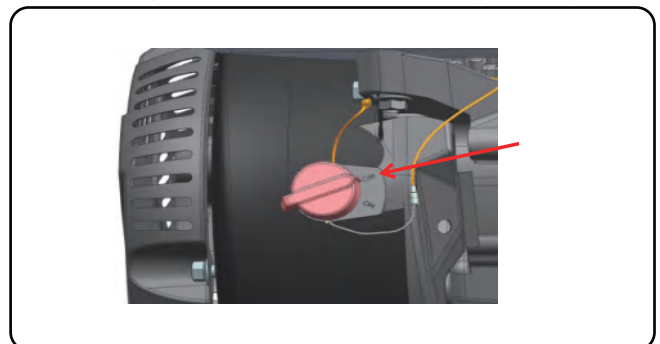

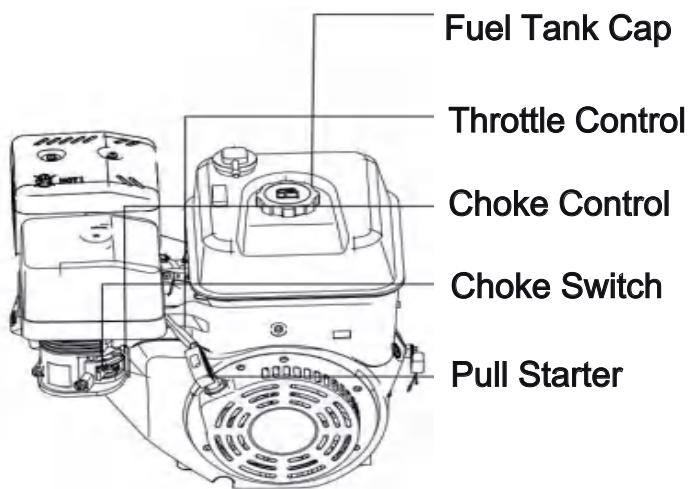
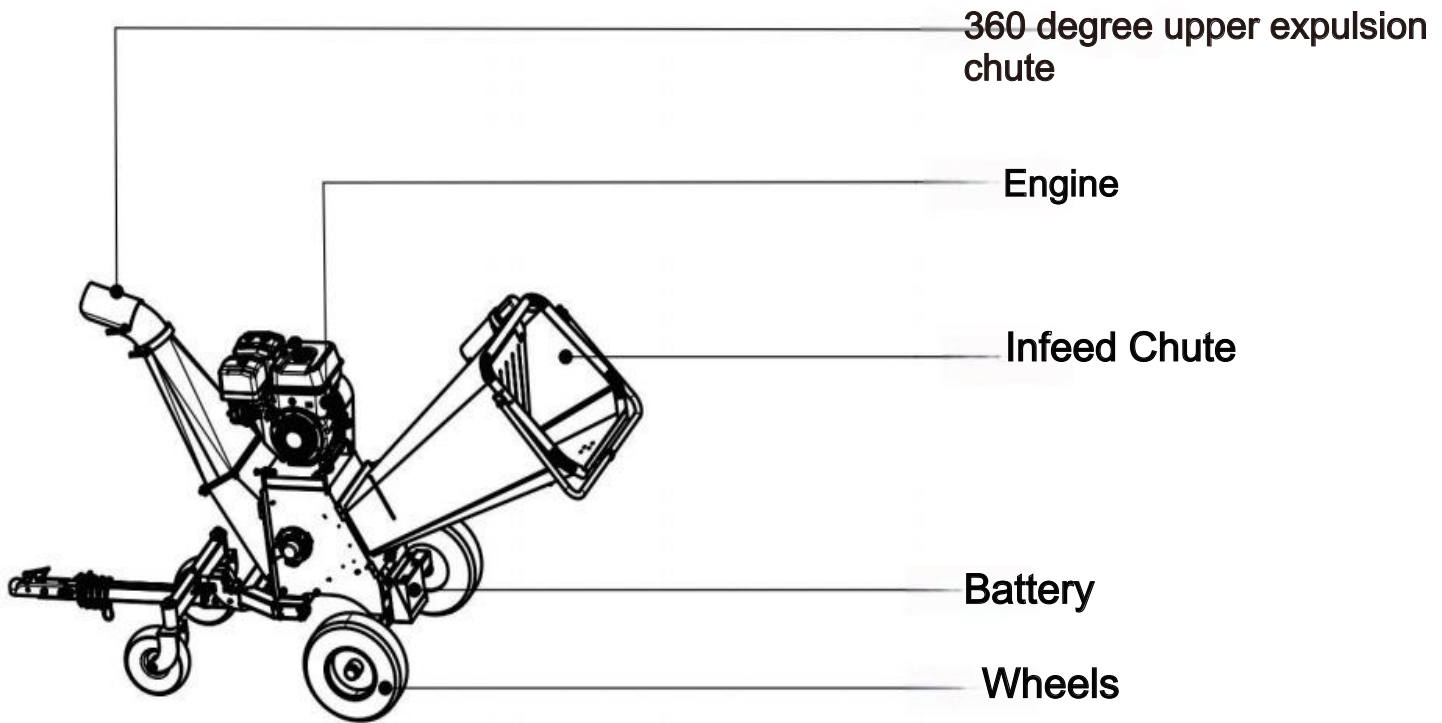

Maintaining the Wood Chipper

Regular maintenance is the way to ensure the best performance and long life of your machine. Please refer to this manual and the engine manufacturer's user manual for maintenance procedures.

WARNING

Before performing any maintenance procedure or inspection, stop the engine, wait five minutes to allow all parts to cool. Disconnect the spark plug wire, keeping it away from the spark plug. Disconnect the Battery Terminals (Electric start only).

Regular Maintenance Checklist

Procedure	Before Each Use	Every 3 Hours	Every 25 Hours	Every 100 Hours
Check engine oil level	Δ			
Check general equipment condition	Δ			
Check wedge for sharpness	Δ			
Check belts	Δ			
Check tire pressure			Δ	
Clean engine exterior and cooling			Δ	
Change Engine Oil	First time 5hours		Δ	
Replace air filter			Δ	
Replace spark plug				Δ

Engine Service

Refer to the engine manufacturer's user manual for engine maintenance.

Lubrication

NOTICE

All Bearings of your Chipper are sealed units and should have sufficient lubricant to last the life of your machine with normal use.

Greasing the rack and Pinion

NOTICE

All the rack and pinion should be greased before every use.

Troubleshooting Table

SYMPTOM	POSSIBLE CAUSE
<p><i>The engine won't start.</i></p> <p><i>(Please refer to the engine user manual for engine-specific procedures.)</i></p>	<ul style="list-style-type: none"> ➤ <i>Is the ignition switch in the "ON" position?</i> ➤ <i>Is the fuel shut-off valve on?</i> ➤ <i>Are you using fresh, clean gas? If the gas is old, change it. Use a fuel stabilizer if you keep gas longer than 30 days.</i> ➤ <i>Is the spark plug clean? If the spark plug is dirty or cracked, change it. If it's oily, leave it out, hold a rag over the plug hole and pull the recoil cord several times to blow out any oil in the cylinder, then wipe off the plug and reinsert it.</i>
<p><i>The engine lacks power or is not running smoothly.</i></p> <p><i>(Please refer to the engine user manual for engine-specific procedures.)</i></p>	<ul style="list-style-type: none"> ➤ <i>Check that the Throttle Lever is in the "Run" position.</i> ➤ <i>Is the air filter clean? If it's dirty, change it following the procedure in the engine manufacturer's owner's manual.</i> ➤ <i>Is the spark plug clean? If it's fouled or cracked, change it. If it's oily, leave it out, hold a rag over the plug hole and pull your recoil cord several times to blow out any oil in the cylinder, then wipe off the plug and reinsert it.</i> ➤ <i>Are you using fresh, clean unleaded gas? If it's old, change it. Use a fuel stabilizer if you keep gas longer than 30 days.</i> ➤ <i>Does your engine have the right amount of clean oil? If it's dirty, change it following the procedure in the engine manufacturer's owner's manual.</i> ➤ <i>Check the oil level and adjust as needed.</i>
<p><i>Engine smokes.</i></p> <p><i>(Please refer to the engine user manual for engine-specific procedures.)</i></p>	<ul style="list-style-type: none"> ➤ <i>Check the oil level and adjust as needed.</i> ➤ <i>Check the air filter and clean or replace if needed.</i> ➤ <i>You may be using the wrong oil—too light for the temperature. Refer to your Engine Owner's Manual for detailed information.</i> ➤ <i>Clean the cooling fins if they're dirty.</i>
<p><i>Machine does not seem to have full chipping power.</i></p>	<ul style="list-style-type: none"> ➤ <i>The belts may be too loose and slipping. Adjust or replace belts as need.</i>

Explosion View and parts list

Ref.No.	Description	Ref.No.	Description
1	Rubber fixer strip	34	Discharge(middle part)
2	Kill switch cover	35	Discharge(top part)
3	Handle	36	Spacer Ø21*Ø25*95
4	Rubber plate	37	Fore-wheel fixture
5	Emergency stop bar	38	Wheel 4.10-4
6	Bar fixture(left)	39	Washer Ø16*Ø26*3
7	M10 lock nut	40	Screw M16*140
8	Infeed hopper	41	Dust cover
9	Bar fixture(right)	42	M24*1.5 slot nut
10	Seal cover(left)	44	Wheel 16*8.0-7
11	Infeed Damping Rubber	45	Flange
12	Engine(recoil/electric start)	46	Rear wheel axle
13	Engine fixture plate	47	Bearing F207
14	Main-frame	48	Roller
15	Spacer Ø35*Ø45*10	49	Blade
16	Kill switch	50	Frame-Switch cover
18	Seal cover(right)	51	Anvil
19	Belt inner cover	52	Anvil fixture
20	Discharge Damping Rubber	53	Battery fixture
21	Arch plate	54	Battery box
22	Front wheel frame	55	Battery 12V20AH
23	Front wheel rotation frame	56	Bearing cover
24	M10 screw and nut	57	M10 nut
25	M10 lock nut	58	SpringØ20*Ø16*Ø2.0*135
26	Axle cover	59	Restore pole
27	Bearing 6204	60	Screw bolt
28	M24*1.5 slot nut	61	V-Belt 17*1143
29	Tow bar	62	Engine pulley
30	Tow hitch	63	Roller Pulley
31	Chain	64	Belt cover
32	Deflector	65	M0*30 screw
33	Discharge(bottom part)	66	Fore-wheel fixing frame

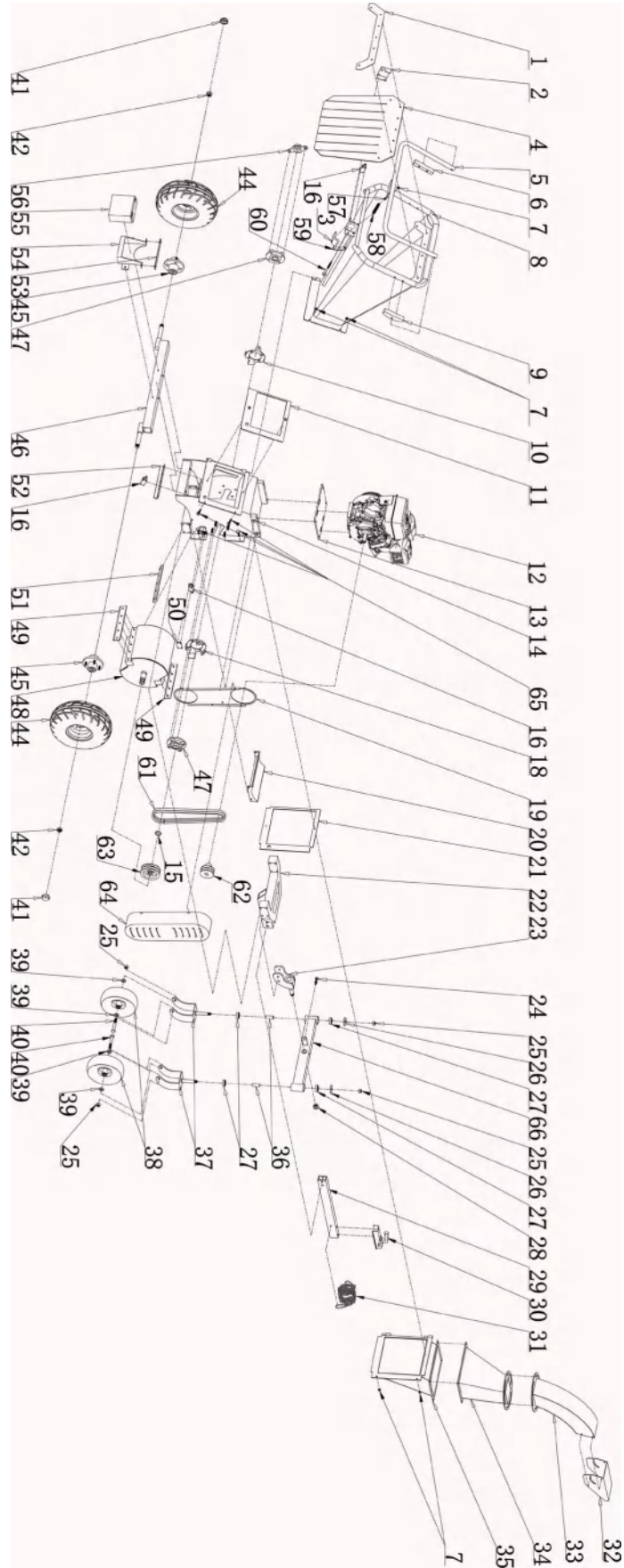

Video on Youtube

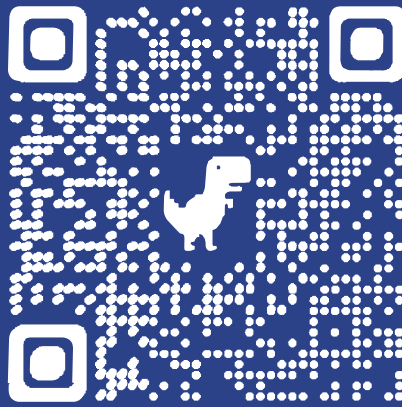

BILT HARD

Service information,
Customer Support (888)680-2849,
inquiry@bilthardusa.com