





















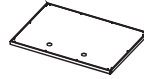







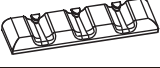

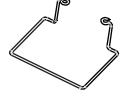









No.	#	QTY / CANT. / QTÉ	Description / Descripción / Description	Image / Imagen / Image
1	EJDB17H4B-RGC	1	Bottom shelf Estante inferior Étagère inférieure	
2	AJQPGDZ01	1	Screw bushing Buje del perno de fijación de la bombona Douille de vi	
3	07-QPG-05-SI	1	LP cylinder screw Perno de fijación de la bombona Vis de bouteille de gaz	
4	05-WXL-20	4	Caster Rueda Roulette	
5	EJCB03	2	Side panel Panel lateral Panneau latéral	
6	EJHB024B	1	Rear panel Panel trasero Panneau arrière	
7	EJGDSJB01	2	Triangle support plate Placa de soporte triangular Plaque de support triangulaire	
8	EJQPDG02-RGC	1	LP cylinder barrier bar Barra de seguridad para la bombona de gas Barre de barrière de bouteille de gaz	
9	EJHL05H4B	1	Cart front beam Barra frontal del carro Poutre avant du chariot	
10	EJQPGRB01-DS1	1	Thermal baffle Deflector térmico Panneau isolant	
11	EJLTGDBL02	1	Grease tray bracket (L) Fijación de Bandeja de recojida de grasa (I) Support du Lèchefrite (G)	
12	EJLTGDBR02	1	Grease tray bracket (R) Fijación de Bandeja de recojida de grasa (D) Support du Lèchefrite (D)	
13	EJSM044B-RGC	2	Cabinet door Puerta del armario Porte d'armoire	
14	EJMGDPL01	1	Beam connector (L) Unión de la barra (I) Connecteur de faisceau (G)	
15	EJMGDPR01	1	Beam connector (R) Unión de la barra (D) Connecteur de faisceau (D)	
16	04-GBS-2-01-200-PG	2	Door handle Tirador de la puerta Poignée de la porte	
17	04-BSZ-03-BK	4	Handle sleeve Base de encastre del tirador Manche de poignée	

No.	#	QTY / CANT. / QTÉ	Description / Descripción / Description	Image / Imagen / Image
18		1	Main body Cuerpo principal Corps principal	
19	ET41	1	Side shelf Bandeja lateral Étagère latérale	
20	EB41	1	Side burner shelf Base del quemador lateral Étagère du bruleur d'appoint	
21	08-SLJ-01	2	Side shelf decoration board Panel decorativo de la bandeja lateral Panneau décoration de la étagère latérale	
22	ELYB02-LS4	1	Bottom shelf Estante inferior Étagère inférieure	
23	07-GGL-38-SI	1	Grease cup holder Soporte de la taza de grasa Graisser le porte-gobelet	
24	ELJYP034B-RGC-DS2	1	Crease tray Bandeja de recogida de grasa Lêchefrite	
25	ELFHB02	4	Flame tamer Regulador de llama Atténuateur de flammee	
26	03-ZTW-E-02-TC4	2	Cooking grate Rejilla para asar Grille de cuisson	
27	ELBWW014B-SS4	1	Warming rack Rejilla para calentar Grille de réchauffement	
28	06-WDJ-3-02	1	Thermometer Termómetro Thermomètre	

No.	#	Image / Imagen / Image	No.	#	Image / Imagen / Image
A	M5×10	 ×46	H	Stud with nut Espárrago con tuerca integrada Goujon avec écrou	 ×4
B	Washer Arandela Rondelle	 ×4	I	Washer Arandela Rondelle	 ×1
C	M4×10	 ×4	J	M5×10	 ×8
D	M5×12	 ×10	K	M4×8	 ×2
E	Magnet Imán Aimant	 ×1	L	Pin Clavija Goupille	 ×1
F	M6×15	 ×22	M	M5×12 (SS)	 ×3
G	M5×5 (SS)	 ×3			

TOOLS REQUIRED / HERRAMIENTAS REQUERIDAS / OUTILS REQUIS

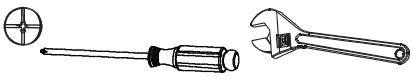
Phillips screwdriver Destornillador phillips Tournevis phillips	Wrench Llave Clé	
---	------------------------	--

Before beginning assembly, make sure all parts are present. If any parts are missing or damaged, do not attempt to assemble the products. Contact customer service for replacement parts via telephone or email.

- Tools needed (not included): Phillips screwdriver and wrench
- Approximate assembly time: 60 minutes
- Note: 1. The right and left sides of the grill are designed as if you are facing the front of the grill.
2. Model shown for illustration purpose only, specific please in kind prevail.

Antes de comenzar el montaje, asegúrese de que todas las piezas estén presentes. Si falta alguna pieza o está dañada, no intente ensamblar los productos. Póngase en contacto con el servicio de atención al cliente para obtener piezas de repuesto por teléfono o correo electrónico.

- Herramienta necesaria (no incluido): Destornillador phillips y llave
- Tiempo aproximado de ensamblaje: 60 minutos
- Nota: 1. Los lados derecho e izquierdo de la parrilla están diseñados como si estuvieras frente a la parte delantera de la parrilla.
2. El modelo que se muestra es sólo para fines ilustrativos, prevalecen los específicos en especie.

Avant de commencer l'assemblage, assurez-vous que toutes les pièces sont présentes. Si des pièces sont manquantes ou endommagées, n'essayez pas d'assembler les produits. Contactez le service de clientèle pour les pièces de rechange par téléphone ou par e-mail.

- Outils nécessaires (non inclus): Tournevis phillips et clé
- Temps nécessaire pour l'assemblage: 70 minutes
- Remarque: 1. Les côtés droit et gauche du gril sont conçus comme si vous faisiez face à l'avant du gril.
2. Le modèle est présenté à des fins d'illustration uniquement, spécifiques en nature prévalent.

1 F  ⊕ ×2

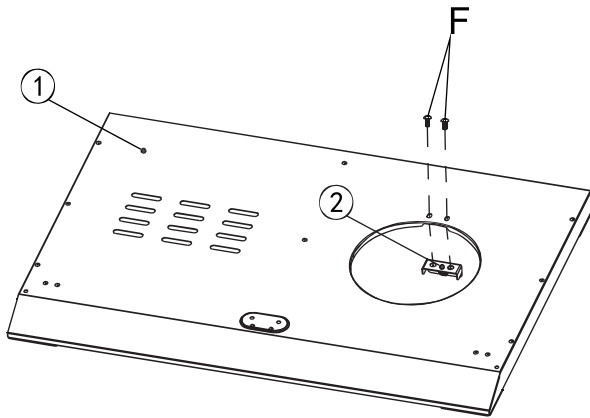

2

- Use the pre-installed screws from the LP cylinder screw.
- Utilice los tornillos preinstalados del tornillo del cilindro LP.
- Utilisez les vis pré-installées de la bonbonne de gaz LP.

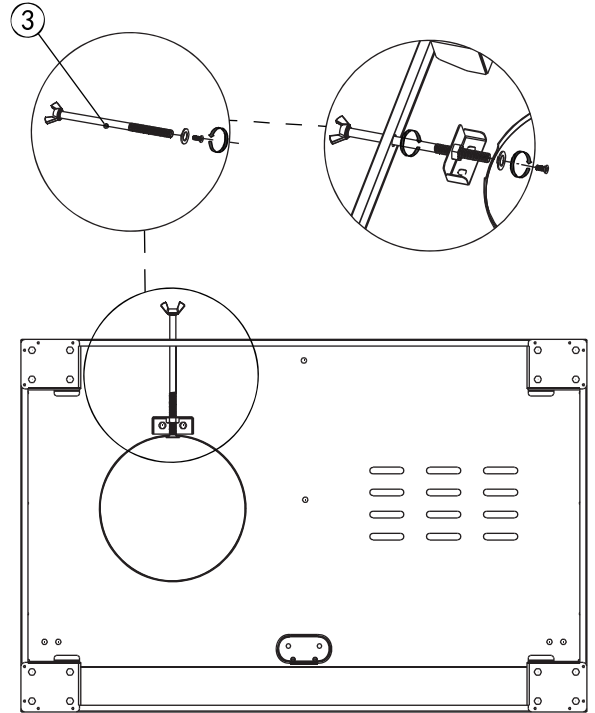

3 F  ⊕ ×16

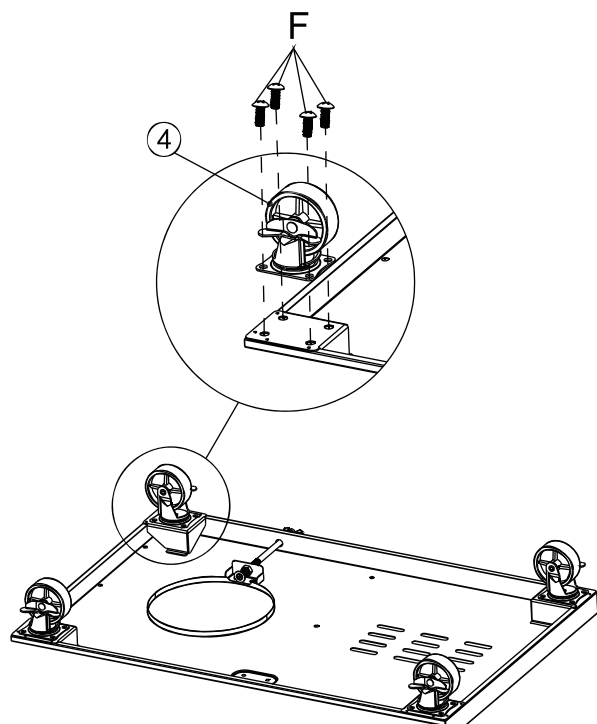

4 A  ⊕ ×4

- Do not fully tighten the screws until step 6.
- No apriete completamente los tornillos hasta el paso 6.
- Ne serrez pas à fond les vis avant l'étape 6.

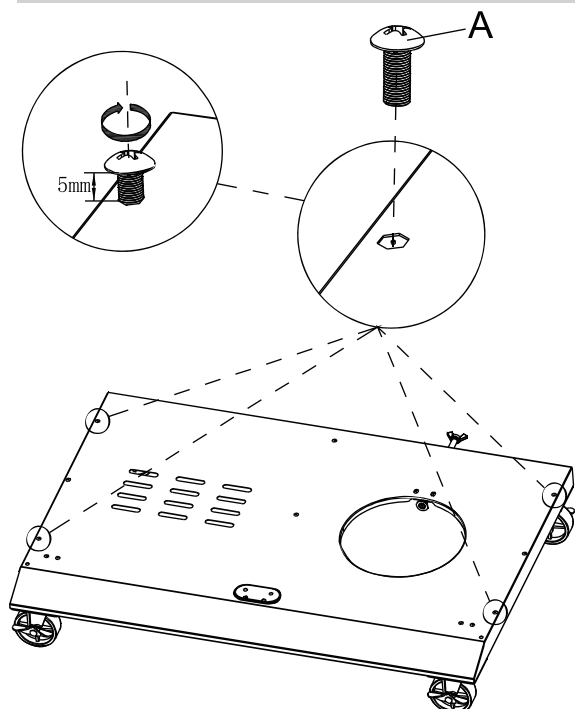

5

- Insert & snap
- Insertar y encajar
- Insérez et enclenchez

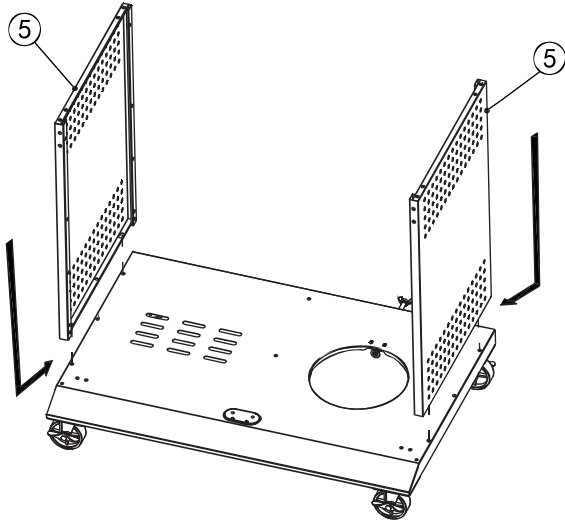

6

A  ⊕ ×2

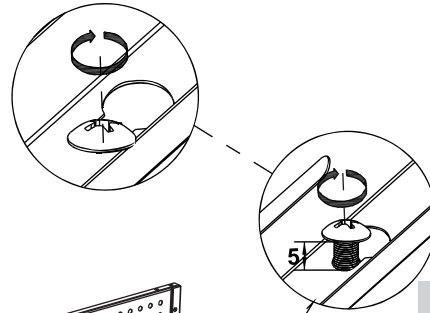

- Snap & tighten
- Encajar y apretar
- Enclenche et serre

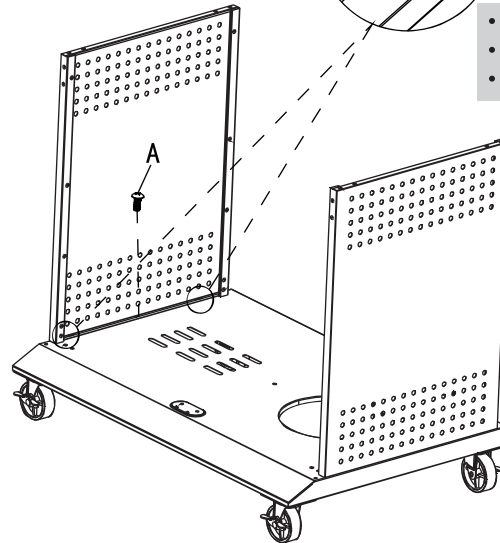

7

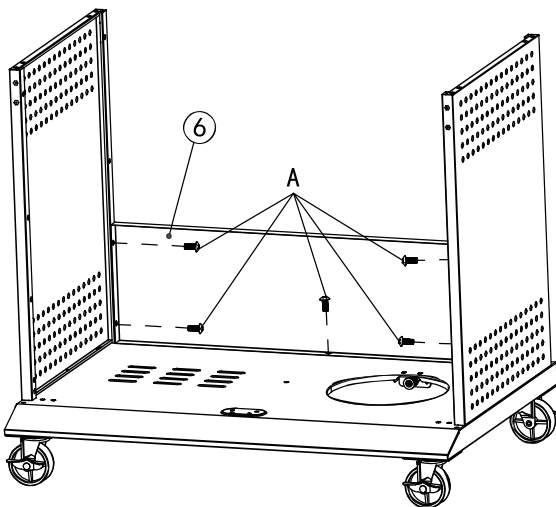

A  ⊕ ×5





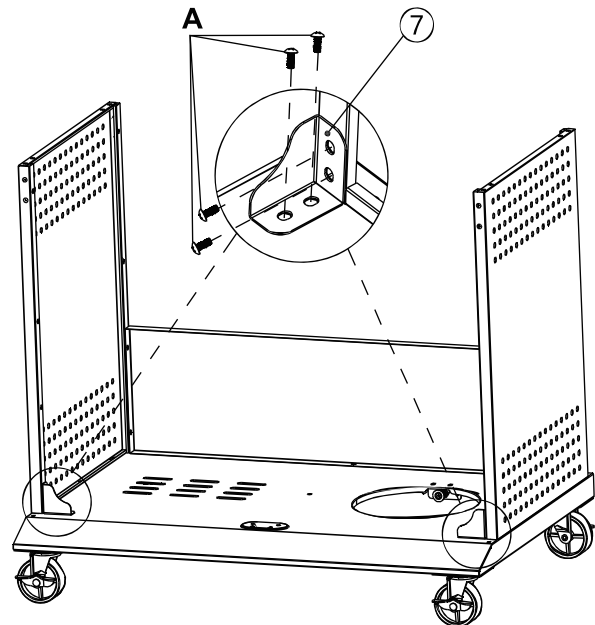

8

A  ⊕ ×8

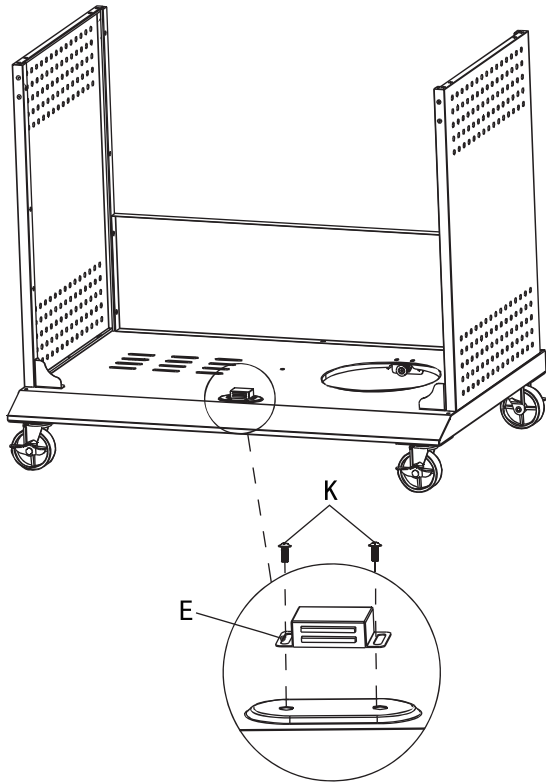



9 K  x2 E  x1

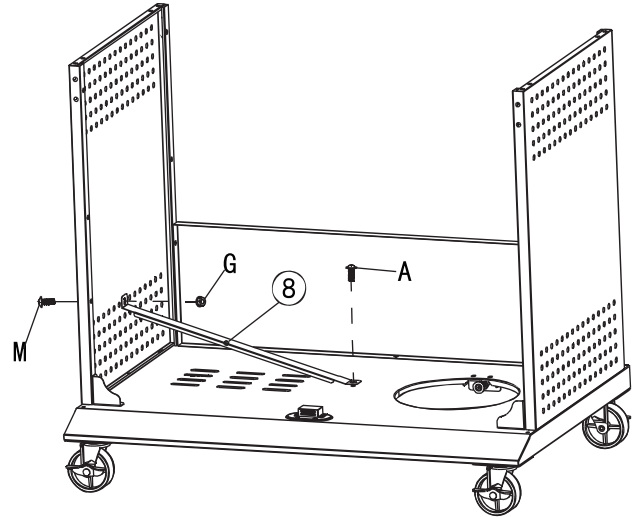

10 A  x1 G  x1
M  x1



11 A  x2 D  x6

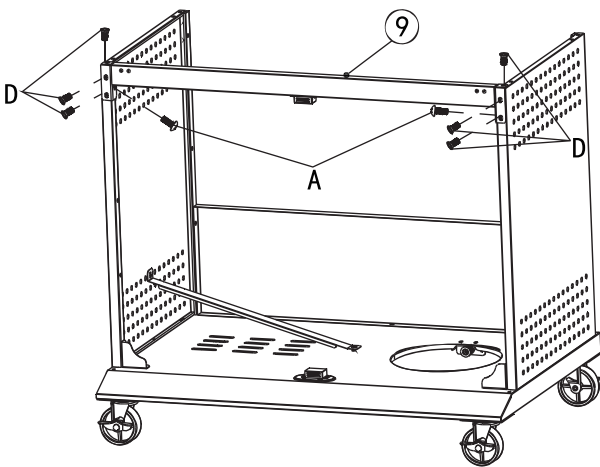

12 A  x2

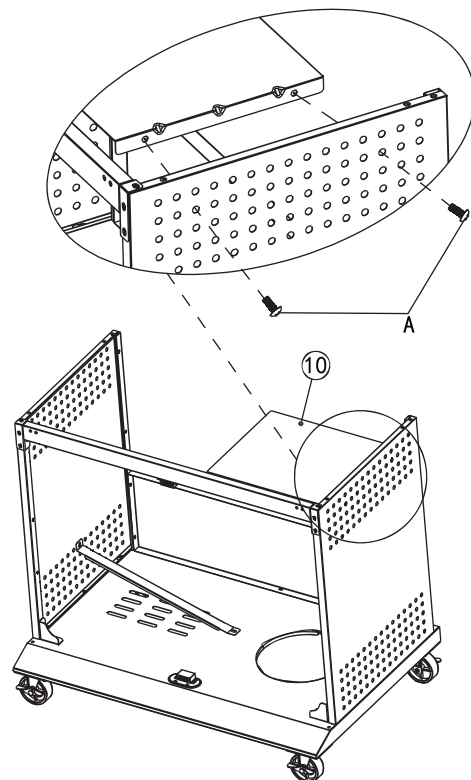

13 D  ×4

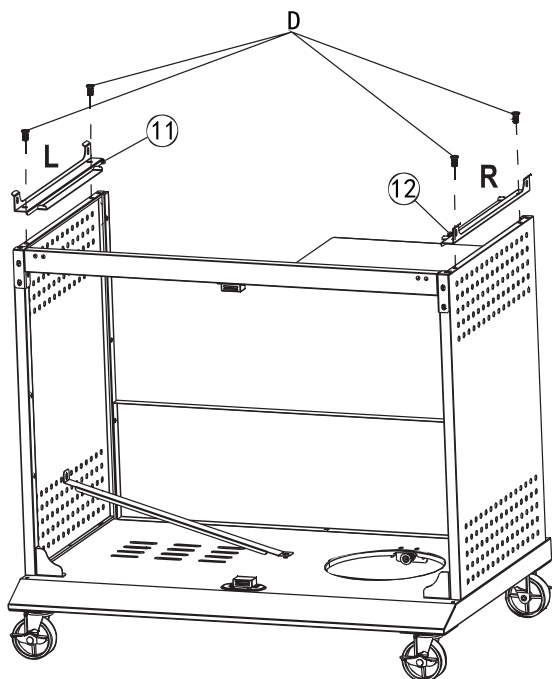

14 H  ×4

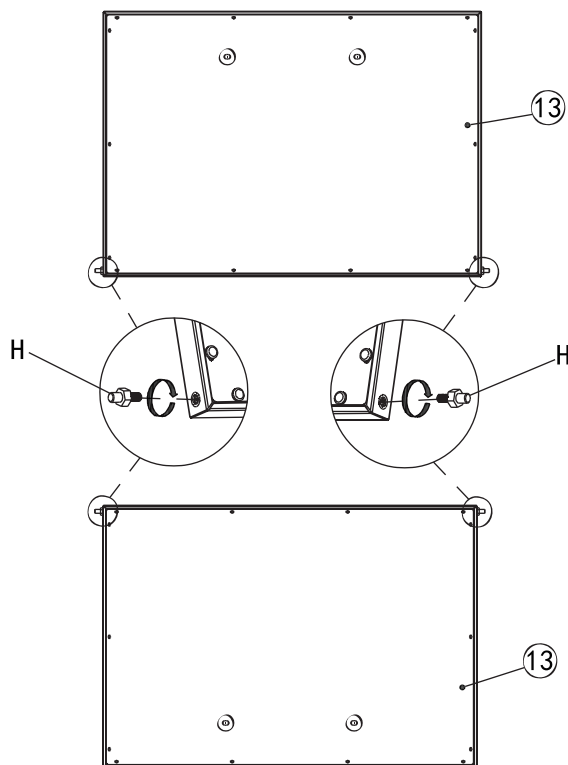

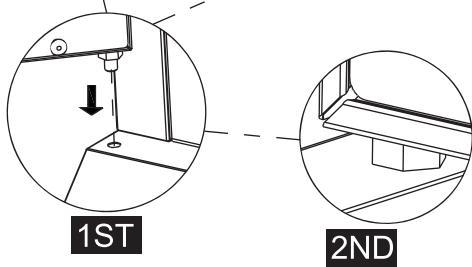
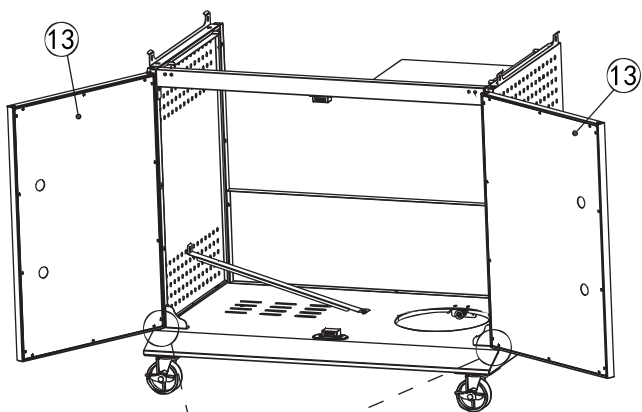

15

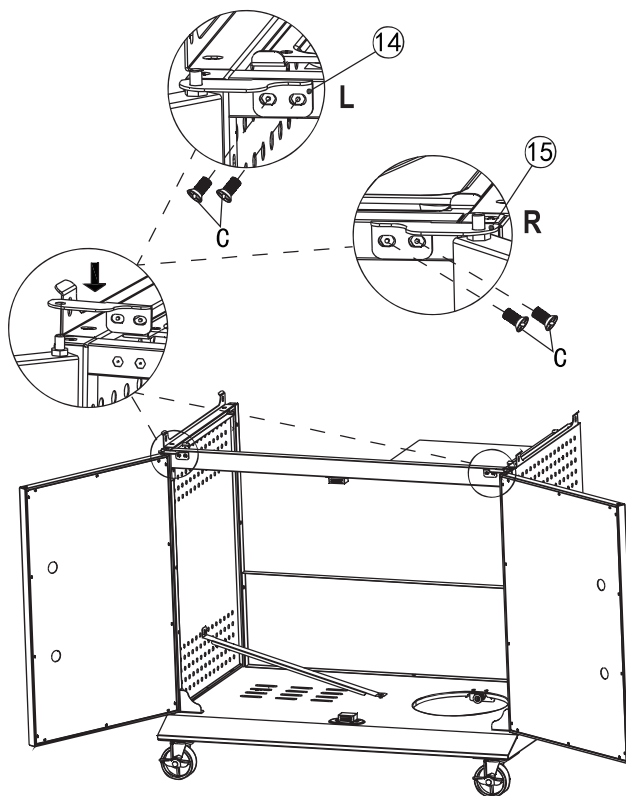

16 C  ×4



17 B  x4 F  x4

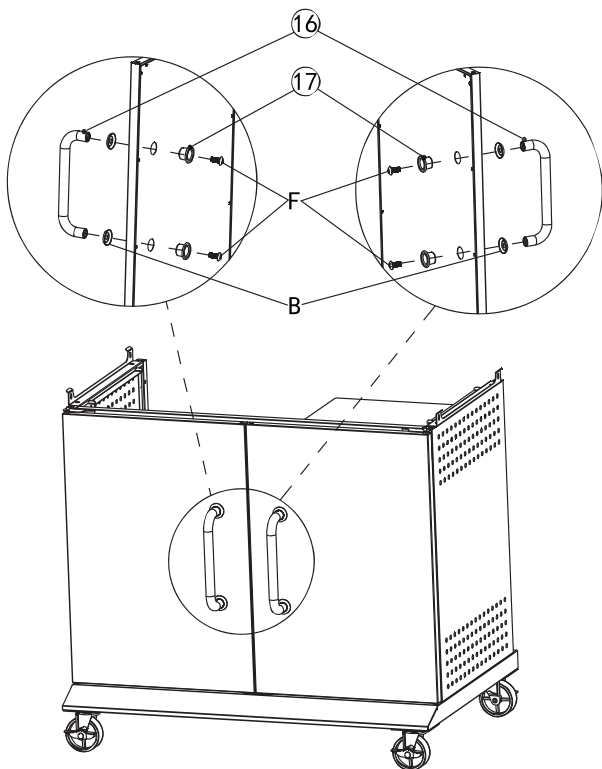

18

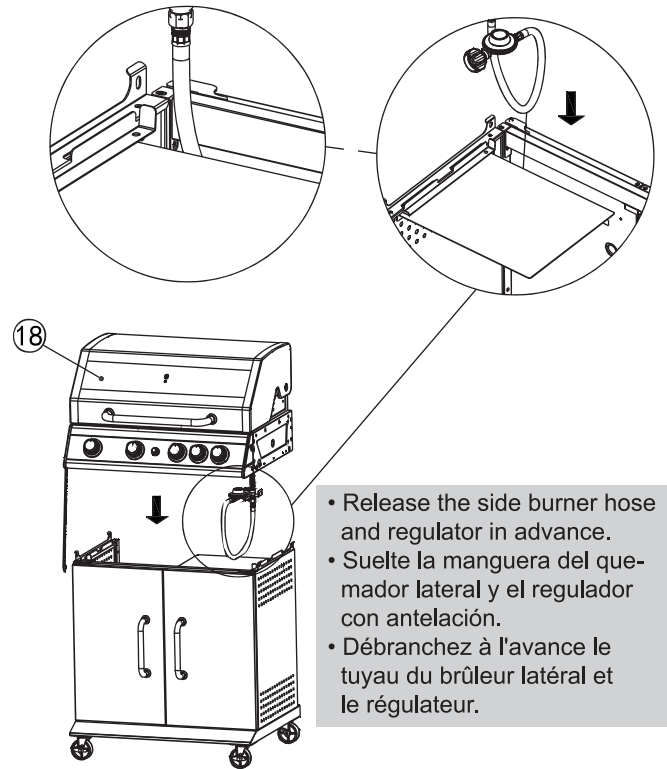

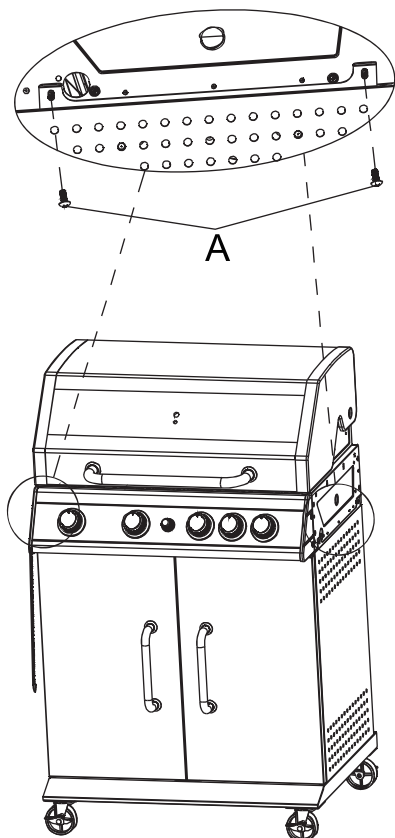

- Release the side burner hose and regulator in advance.
- Suelte la manguera del quemador lateral y el regulador con antelación.
- Débranchez à l'avance le tuyau du brûleur latéral et le régulateur.

19 A  x4

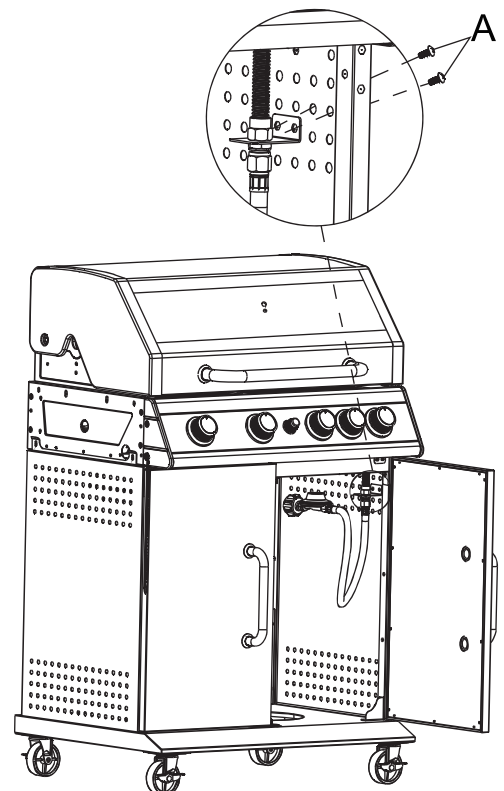

20 A  x2



21 J  x8

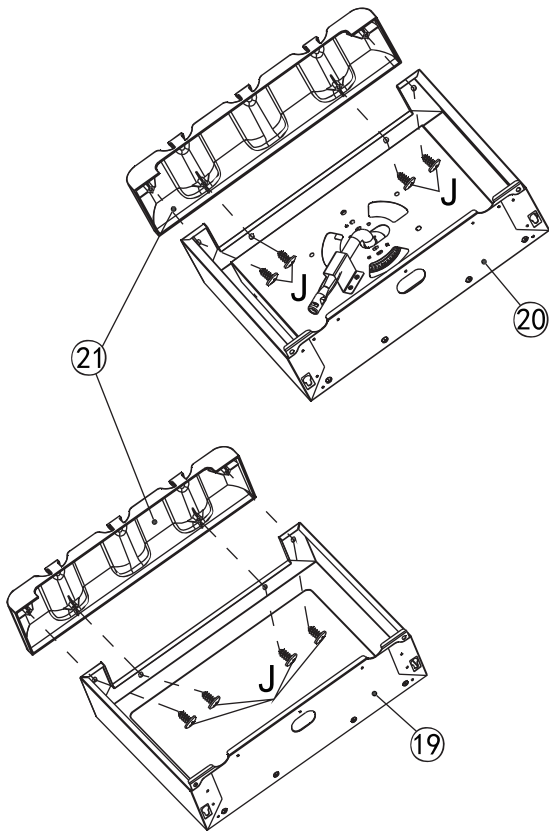

22 A  x4

- Do not fully tighten the screws until step 25.
- No apriete completamente los tornillos hasta el paso 25.
- Ne serrez pas à fond les vis avant l'étape 25.

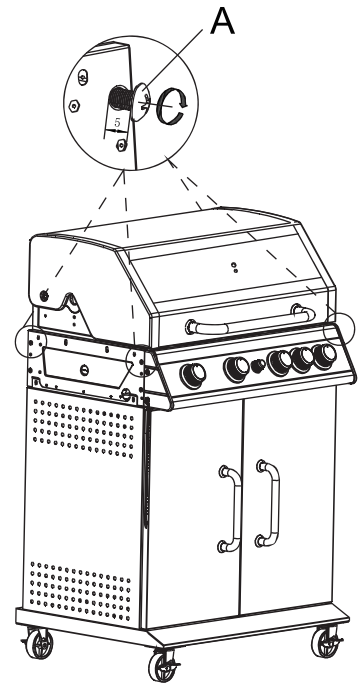

23

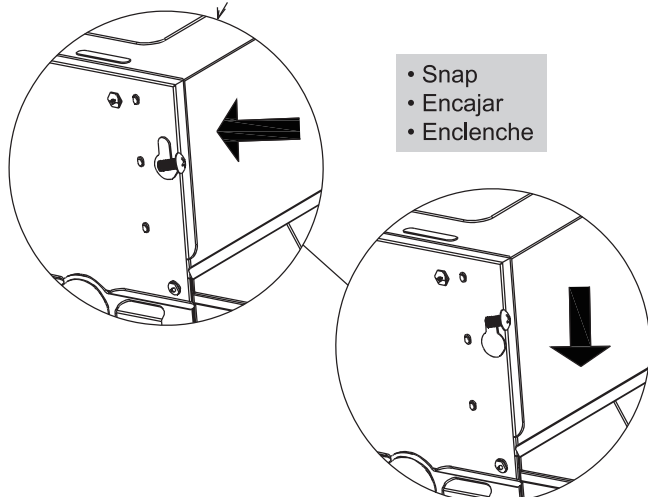
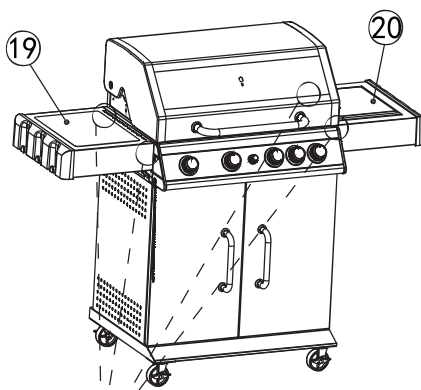

- Snap
- Encajar
- Enclenche

24 A  x8

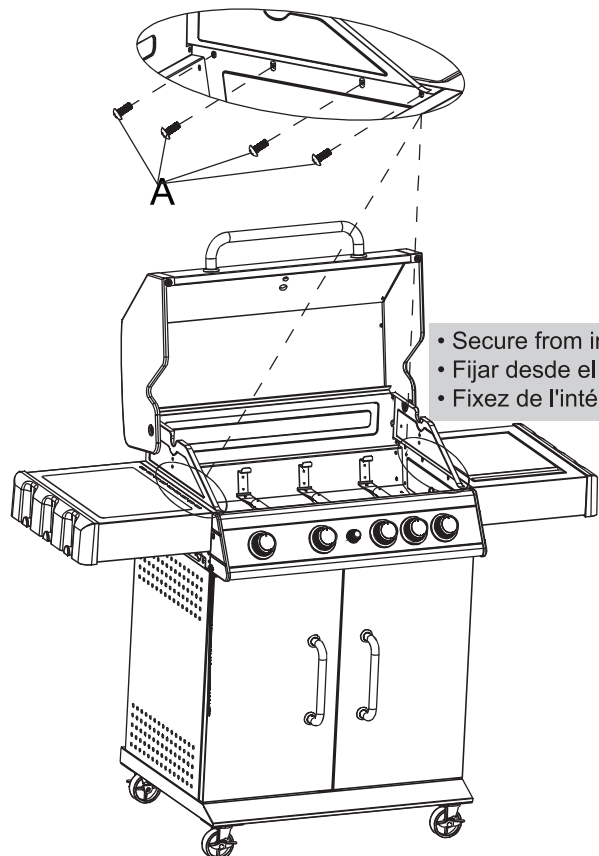

- Secure from inside
- Fijar desde el interior
- Fixez de l'intérieur

25 A  ×4

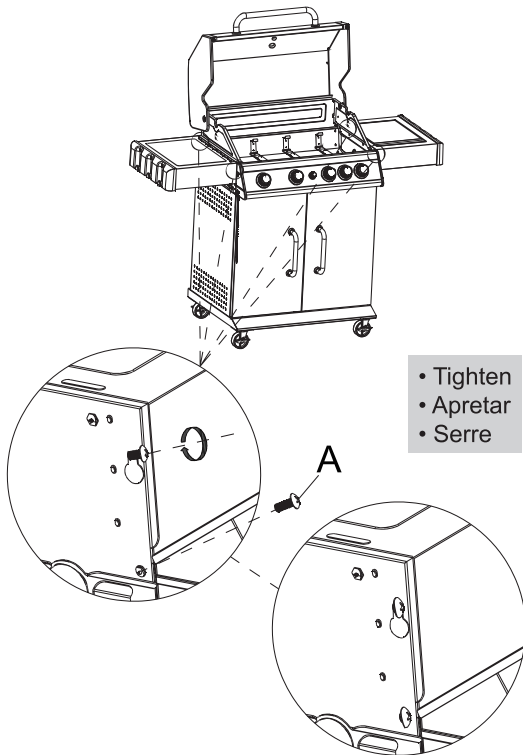

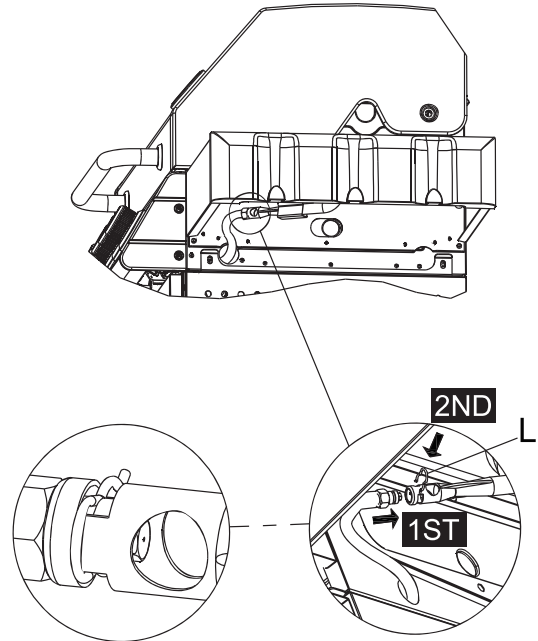

26 L  ×1

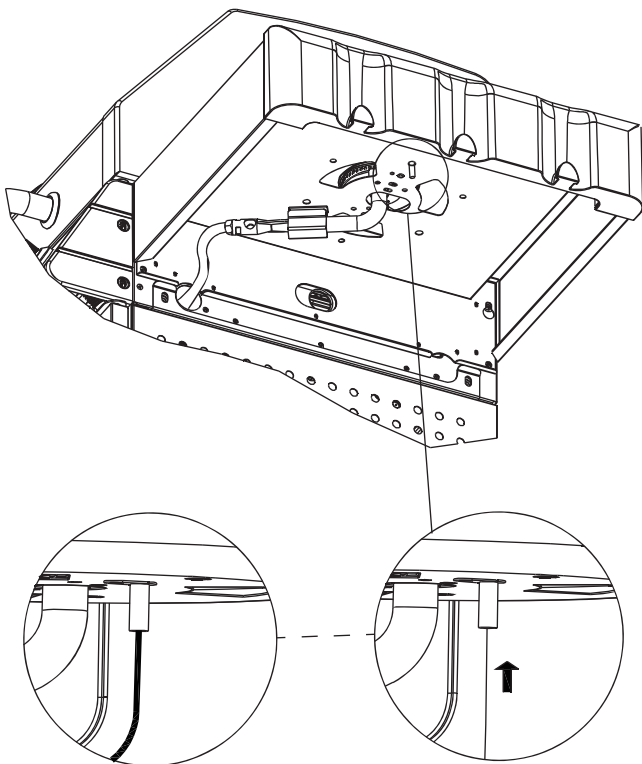

- Pass through the hole in the side panel and connect to the side burner.
- Pase a través del orificio del panel lateral y conecte al quemador lateral.
- Passez à travers le trou du panneau latéral et connectez-vous au brûleur latéral.

27

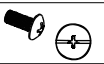

28 G   ×2 M  ×2

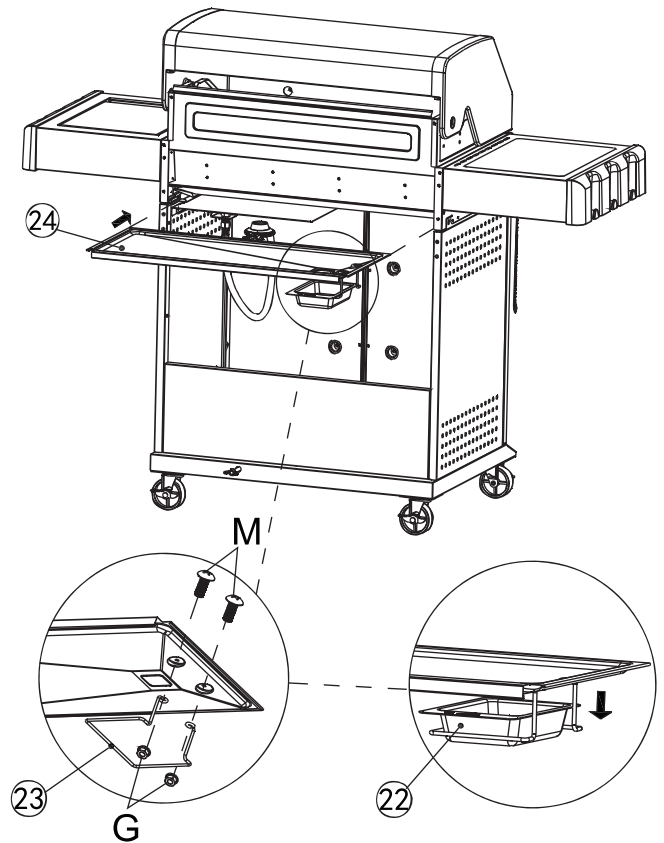

29

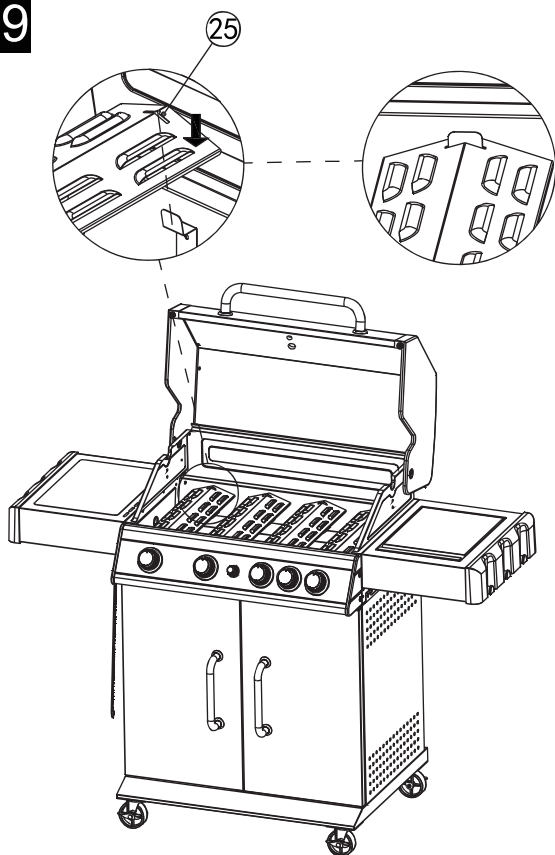

30

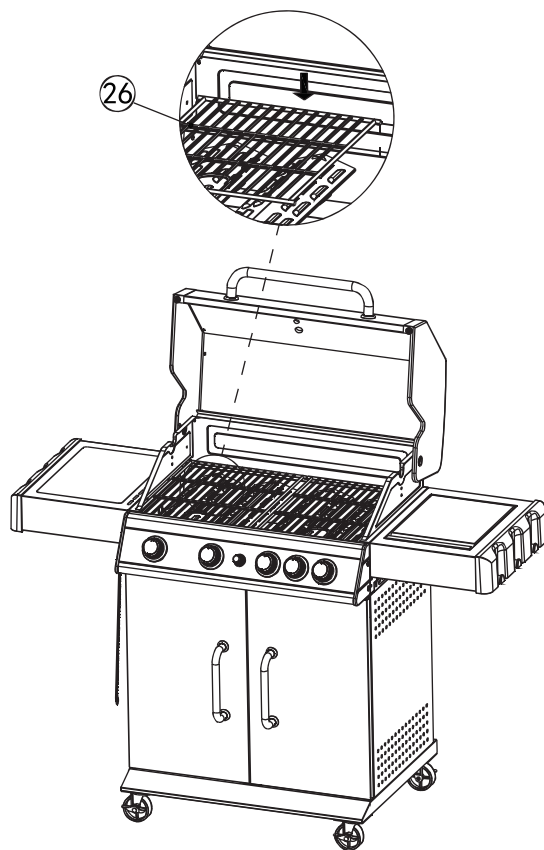

31

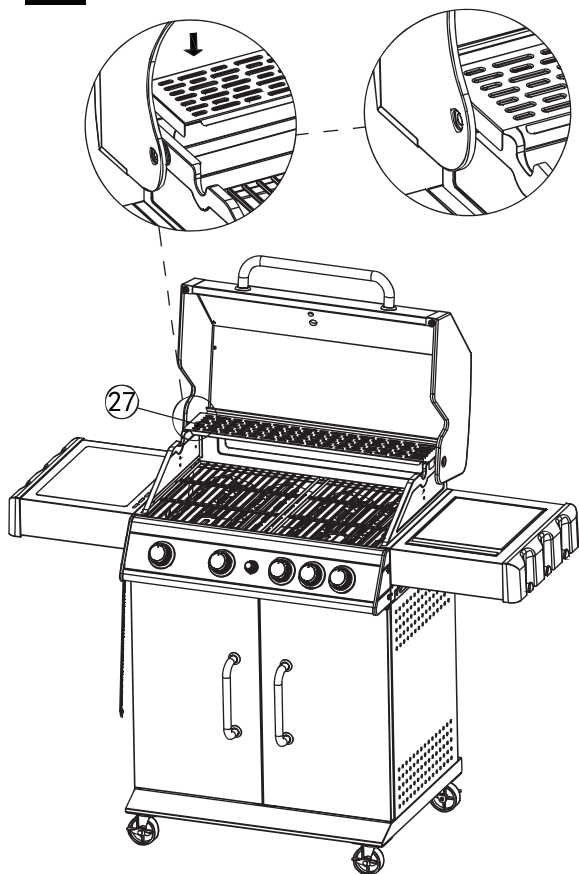

32

I ⊙ ⊙ ×1

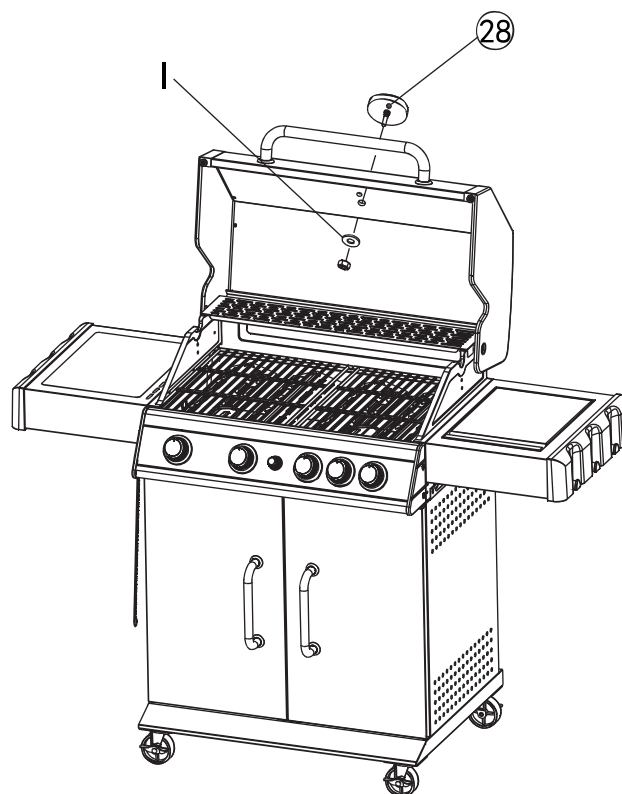

33

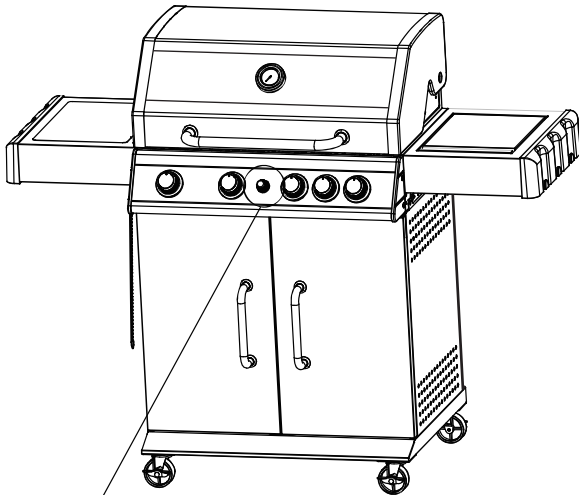

- AA battery not included.
- Pila AA no incluida.
- Pile AA non incluse.

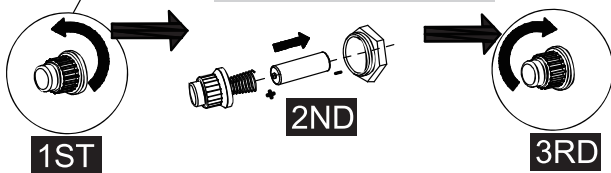

**Thank You
For Choosing Us.**

**Any Problem!
We Can Help!**

**Customer
Service**

1-800-618-6798

Monday to Friday (8:30 am - 5:00 pm EST)

service@royalgourmetusa.com