

SharkBite Max™

FNPT Ball Valve

SharkBite Max™ allows users to connect pipe with ease - no tools needed. This new design features a stainless steel retainer for extra strength, higher pressure ratings (250 psi) and a lower insertion effort than previous versions of SharkBite Brass Push-to-Connect fittings. SharkBite Max fittings do not require a PEX stiffener and are compatible with PEX, copper, CPVC, PE-RT and HDPE*.

Applications

Residential and commercial potable water, recirculation, hydronic heating/cooling (up to 50% glycol concentration) and direct burial.

Specifications Data

Materials	
Body	Lead-Free DZR Brass
O-ring	EPDM
Steel Retainer	304 Stainless Steel
Grab Ring	Stainless Steel
Seal Ring	PTFE
Ball	Chrome Plated Brass
Handle	Steel with PVC Coating
Lock Nut	Stainless Steel
Spindle	Lead-Free DZR Brass

Pipe Insertion Depth	
Fitting Size	Insertion Depth
1/2"	1.00 in.
3/4"	1.25 in.

Performance	
Max Working Pressure	
Max Pressure	250 psi
Max Temperature	200°F (93°C)

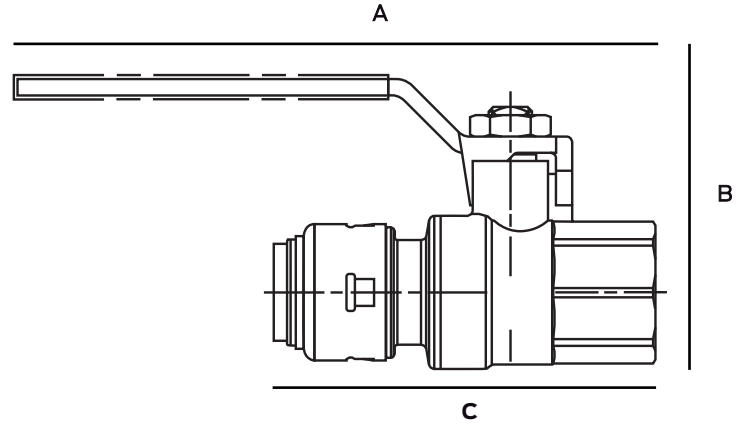

Dimensions (Inches)				
Part #	Size	A	B	C
UR22182	1/2" x 1/2" FNPT	4.7	2.1	2.8
UR22186	3/4" x 3/4" FNPT	4.8	2.4	3.2

Certifications & Listings

ASME A112.4.14/CSA B125.14, NSF/ANSI 14, NSF/ANSI/CAN 61, NSF/ANSI/CAN 372

For listing information, please contact Customer Service

* HDPE installations must use a tube stiffener. Sold separately by HDPE manufacturer.

Product Submittal	
Name	
Date	
Architect/Owner	
Contractor	
Tag	
Notes	