

# 5-SHELF Boltless Steel Shelving

with particleboard shelves

**MODELS:**  
 UR301260PB5P-SV  
 UR361872PB5P-SV  
 UR481872PB5P-SV  
 UR482472PB5P-SV

## IMPORTANT SAFETY INFORMATION

Read through this entire manual for important guidelines and instructions prior to assembly. Failure to follow these guidelines and instructions can result in property damage or serious personal injuries.

This unit should be placed on a level surface. Failure to do so can result in poor product performance or create a possible safety hazard. **DO NOT CLIMB, STAND or USE THIS UNIT AS A LADDER. TO PREVENT TIPPING, ALWAYS SECURE TO A WALL WITH SUITABLE FASTENERS, NOT INCLUDED. DO NOT USE THIS UNIT TO STORE AQUARIUMS. CAUTION: CONTAINS SMALL PARTS, KEEP CHILDREN AWAY DURING INSTALLATION. USE TWO OR MORE PEOPLE TO ASSEMBLE AND MOVE THE UNIT TO AVOID INJURY.** Do not use this unit for anything other than the manufacturer's intended purpose. Use care when working with metal parts, wear gloves for protection. Periodically inspect the unit to ensure brace/beam rivets are properly seated into post slots. Keep this manual for future reference.

Do not exceed the maximum weight capacity of 800 lbs (363 kg) for each shelf, not to exceed 4,000 lbs (1,814 kg) for the entire shelving unit. Evenly distribute weight loads across entire shelf surface. Always store larger, heavier items on the bottom levels and small lighter items on the upper levels.

## PARTS

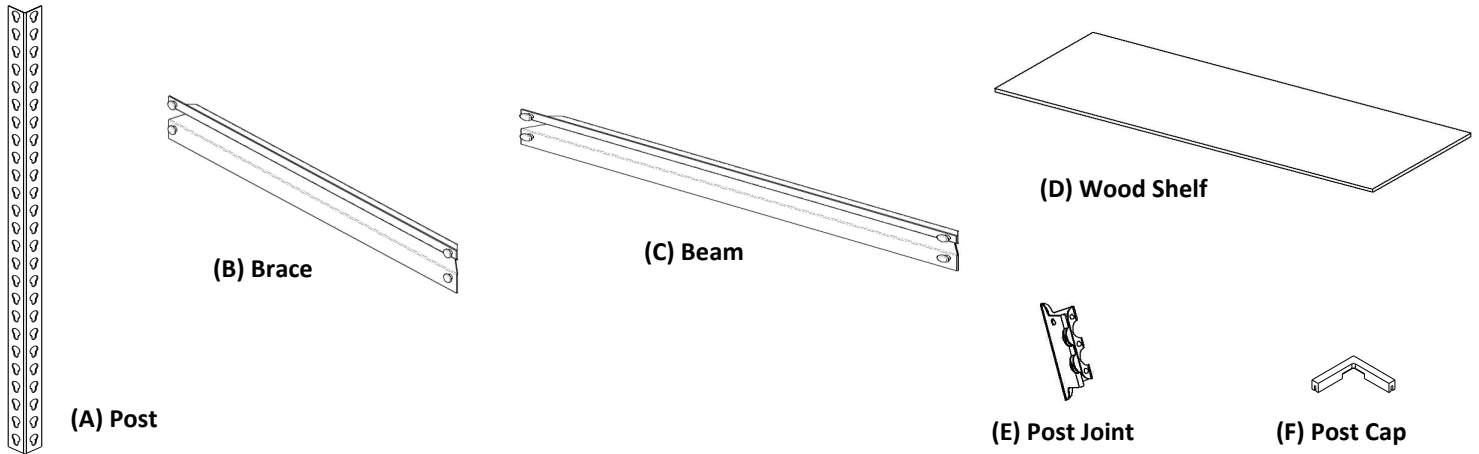

### PARTS LIST

Description	Qty	Model UR301260PB5P-SV (30w x 12d x 60h)	Model UR361872PB5P-SV (36w x 18d x 72h)	Model UR481872PB5P-SV (48w x 18d x 72h)	Model UR482472PB5P-SV (48w x 24d x 72h)
		Part Number	Part Number	Part Number	Part Number
(A) Post	8	URPS30-SV	URPS36-SV	URPS36-SV	URPS36-SV
(B) Brace	10	URBR12-SV	URBR18-SV	URBR18-SV	URBR24-SV
(C) Beam	10	URBM30-SV	URBM36-SV	URBM48-SV	URBM48-SV
(D) Wood Shelf	5	RPB31230	RPB31836	RPB31848	RPB32448
(E) Post Joint	4	MPC0409-SV	MPC0409-SV	MPC0409-SV	MPC0409-SV
(F) Post Cap	8	RL-PC-B1.4	RL-PC-B1.4	RL-PC-B1.4	RL-PC-B1.4

## GENERAL INSTRUCTIONS

Assembly is done with the rivets of the beams and braces fitting into the slots of the post. A rubber mallet may be used on the beams and braces to seat the rivets properly. A hammer can also be used, providing one uses a cloth or a block of wood between the hammer head and the parts to prevent damage. Tap gently and be sure the rivets are straight and fully engaged.

Should you have any comments, damage, missing parts, or problems with assembly of this unit contact us:



**Chat:** [www.edsal.com/chat](http://www.edsal.com/chat) or [www.edsal.com/contact](http://www.edsal.com/contact)



**Email:** [support@edsal.com](mailto:support@edsal.com)



**Phone:** 773-475-3131

**Edsal Manufacturing Co. LLC**  
 Chicago, IL 60609

US Patents & Patents Pending

To obtain replacement parts please provide: Model Number, Part Number & Description, Location Purchased, and Date Purchased

Rev: C063020

# ASSEMBLY INSTRUCTIONS

## Step

### 1

### Figure C

Posts are directional. The narrow end of the slots must point down.

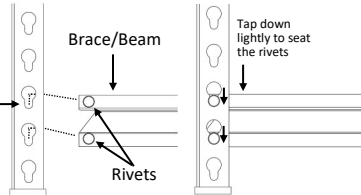

### Figure A

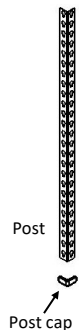

### Figure B

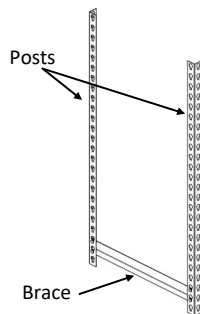

### Figure D

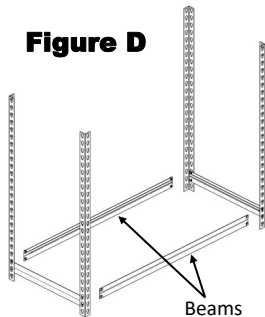

Begin by placing four (4) post caps to the bottom of four (4) posts see figure A). Next, assemble two (2) post with one (1) brace. Skipping one slot from the bottom of the post (see figure B), place the rivets into post with the narrow end of the slots pointing down, and with the shelf ledge of the brace facing up (see figure C). Tap lightly on the top edge of the brace to seat rivets. Repeat with two (2) post and one (1) brace. Next assemble the two (2) post units with two (2) beams, skipping one slot from the bottom of the post (see figure D). Place the rivets into post with the narrow end of the slots pointing down, and with the shelf ledge of the brace facing up (see figure C). Tap lightly on the top edge of the beam to seat rivets.

## Step

### 2

### Figure E

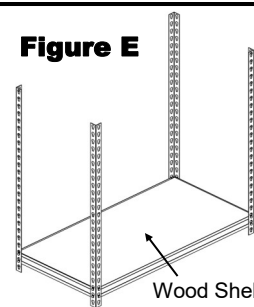

### Figure F

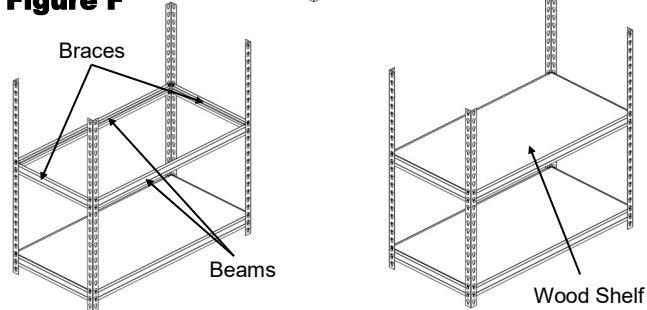

Add a wood shelf to the level previously built (see figure E), then continue working by adding the second level using two (2) beams and two (2) braces in the post slots of your desired location (see figure F). Again, place the rivets of the beams and braces into the post slots with the shelf ledge facing up and tap lightly to seat the rivets. Add a wood shelf to the second level.

## Step

### 3

Note: Posts are directional. The narrow end of slots must point down.

### Figure G

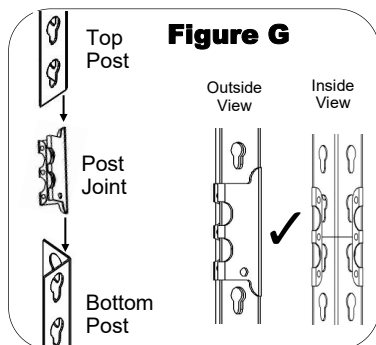

### Figure H

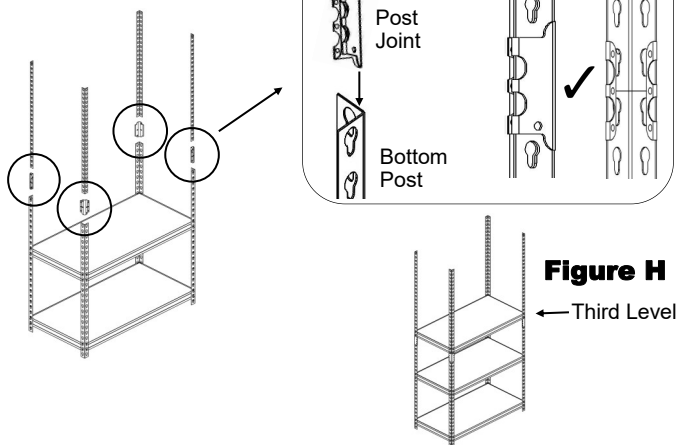

Assemble four (4) posts to the four bottom post assemblies by using four (4) of the post joints. Place the post joint into the top of the bottom post assembly and tap down to properly seat. Next place a post into the top of the post joint and tap down to properly seat (see figure G). Continue by adding the third level using two (2) beams and two (2) braces just above the post joints. Again tap lightly to seat the rivets. Add a wood shelf to the level (see figure H).

## Step

### 4

### Figure I

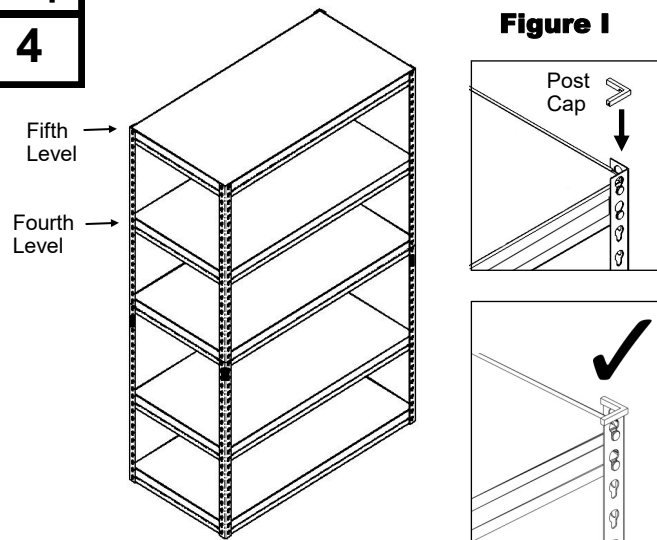

Continue by adding the fourth and fifth level to the unit using two (2) beams and two (2) braces per level. Tap lightly to properly seat the rivets and add the final wood shelves to the unit. Place (4) post caps onto each post (see figure I). Do a final inspection to make sure all rivets are securely seated into the narrow ends of the post slots. The assembly is now complete.