

IE-CT-002-V3

2 Tier White Faux Marble Print Coffee Table(Dark Gray)

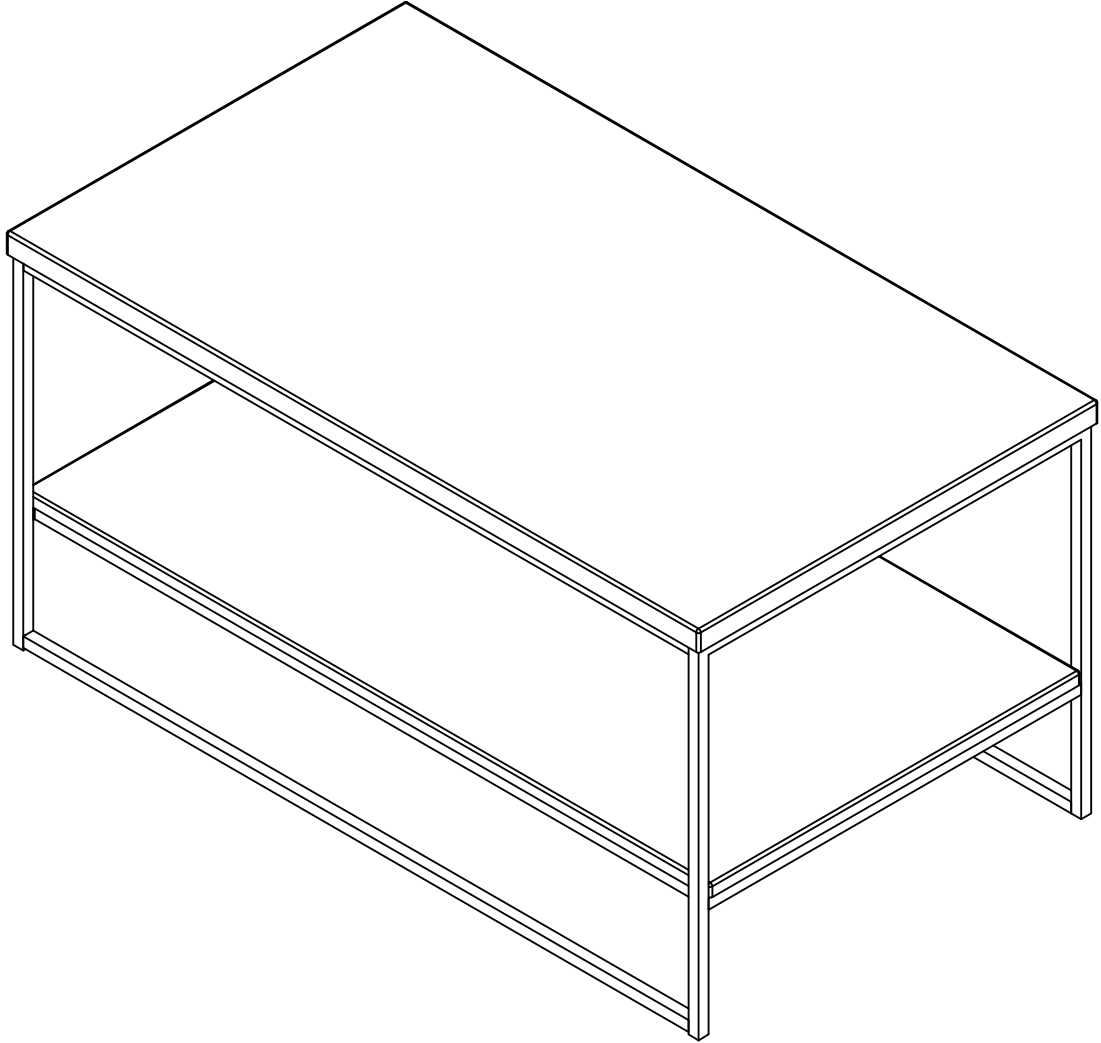

ASSEMBLY INSTRUCTION

ADULT ASSEMBLY REQUIRED

**THE PRODUCT MAY RECOMMENDED
ASSEMBLING BY MORE THAN ONE
PERSON.**

**PLEASE ASK FOR ASSISTANCE AT YOUR
CONVENIENCE BEFORE ASSEMBLING.**

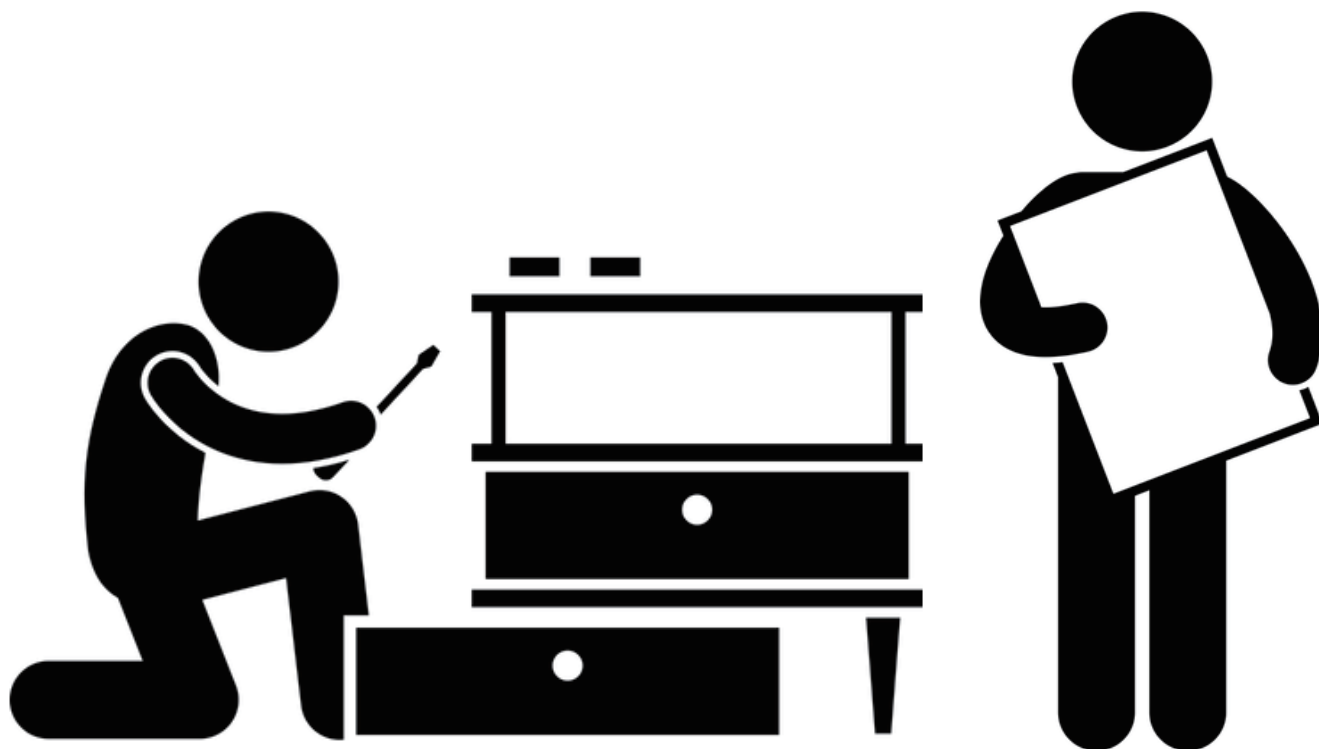

Parts Identification

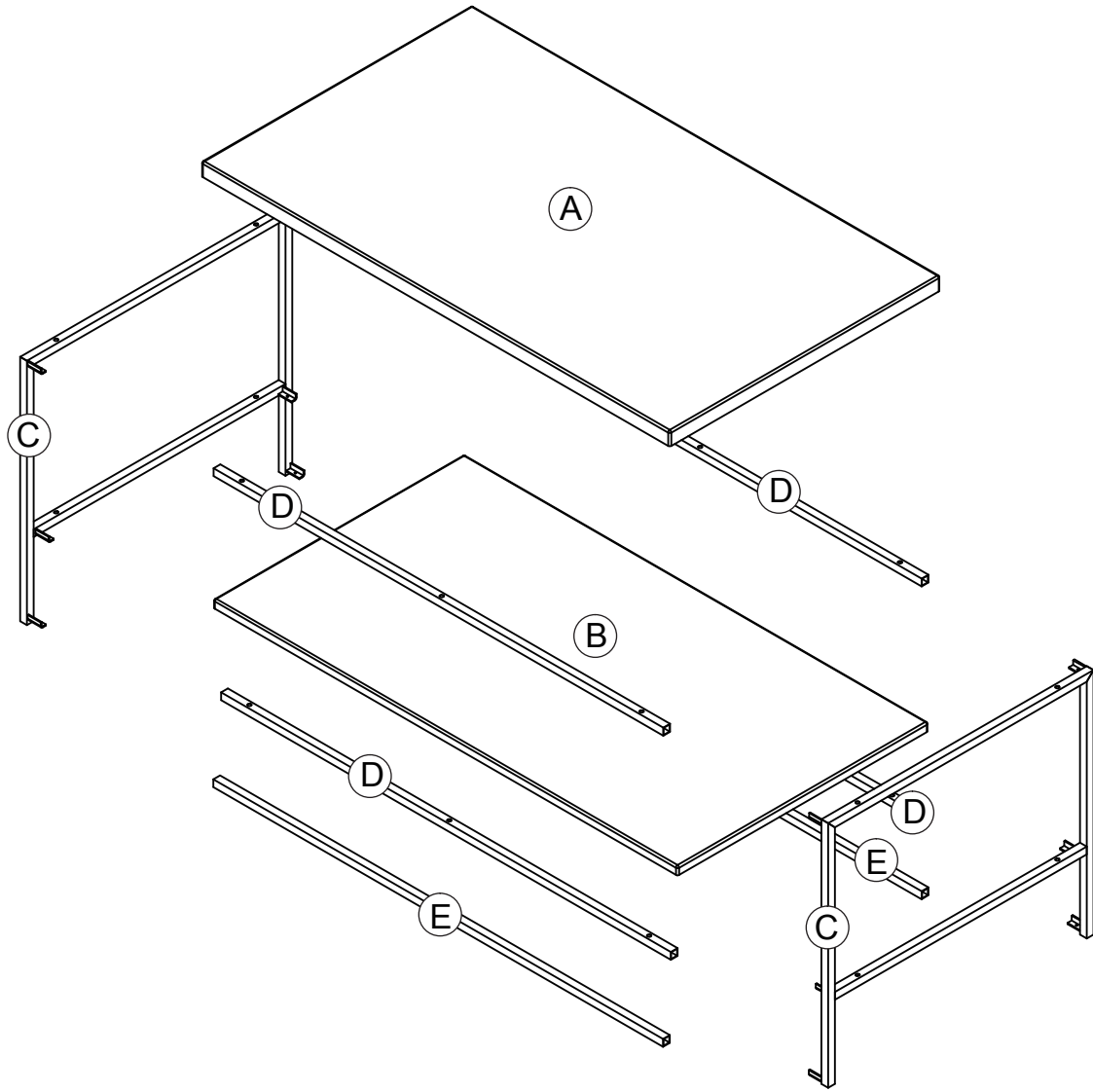

Parts Identification

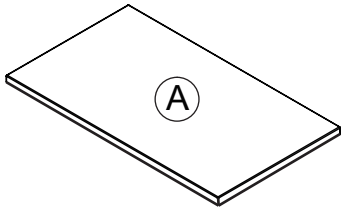

TOP PANEL

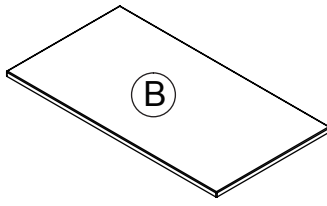

SHELF PANEL

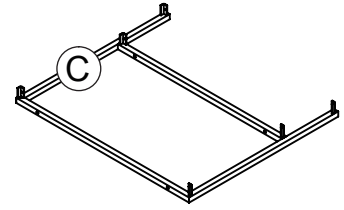

SIDE END x 2

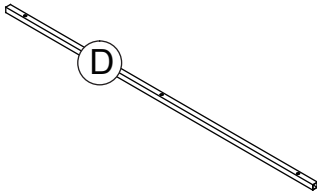

SUPPORT ROD x 4

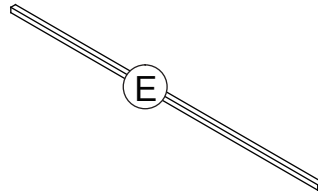

LOWER SUPPORT ROD x 2

Hardware Identification

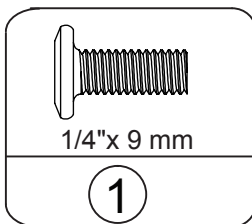

BOLT
QTY: 12+1 SPARE

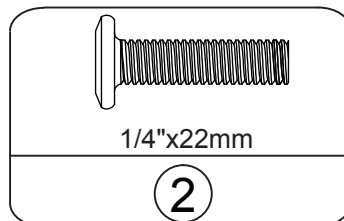

BOLT
QTY: 20+1 SPARE

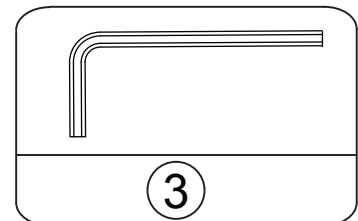

WRENCH
QTY: 1

Step 1

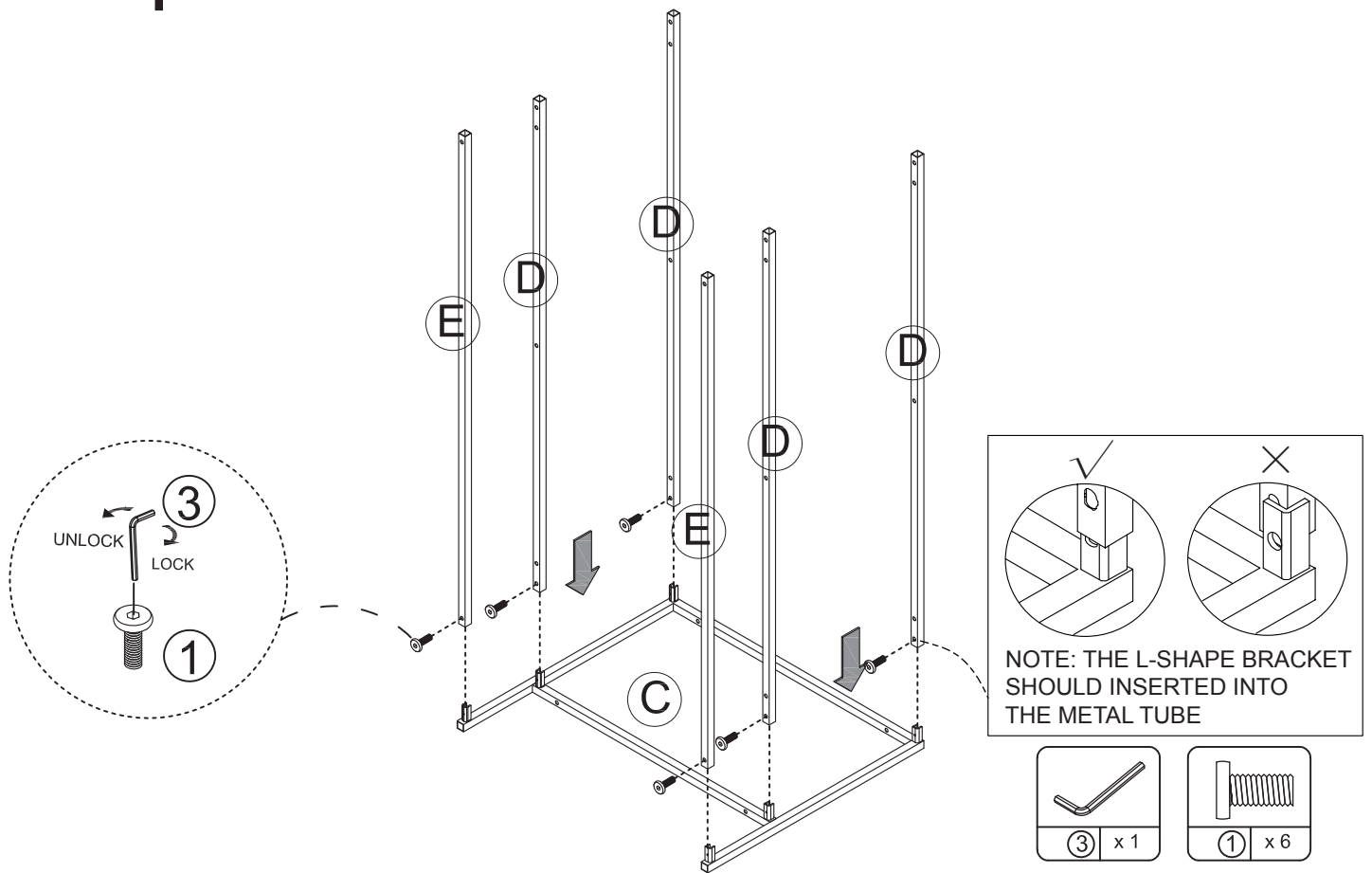

Step 2

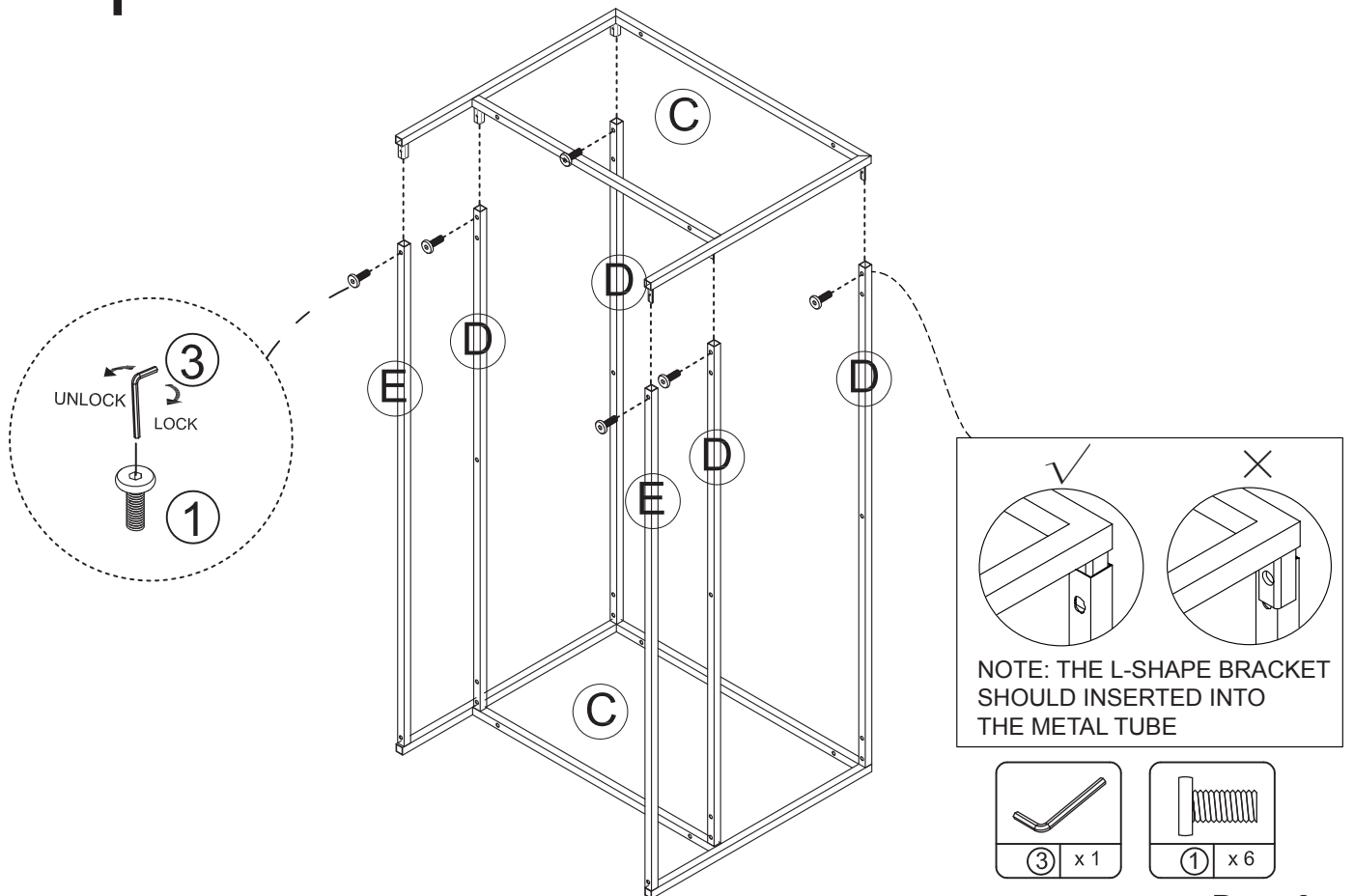

Step 3

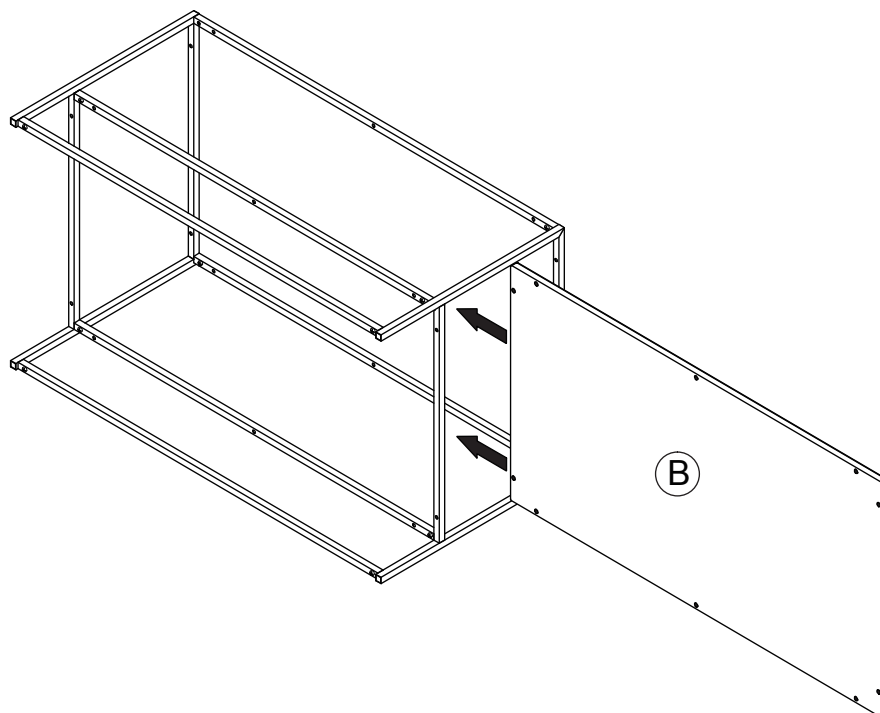

Step 4

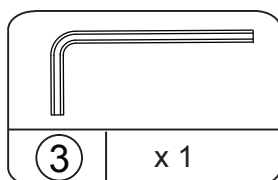
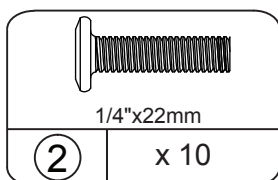
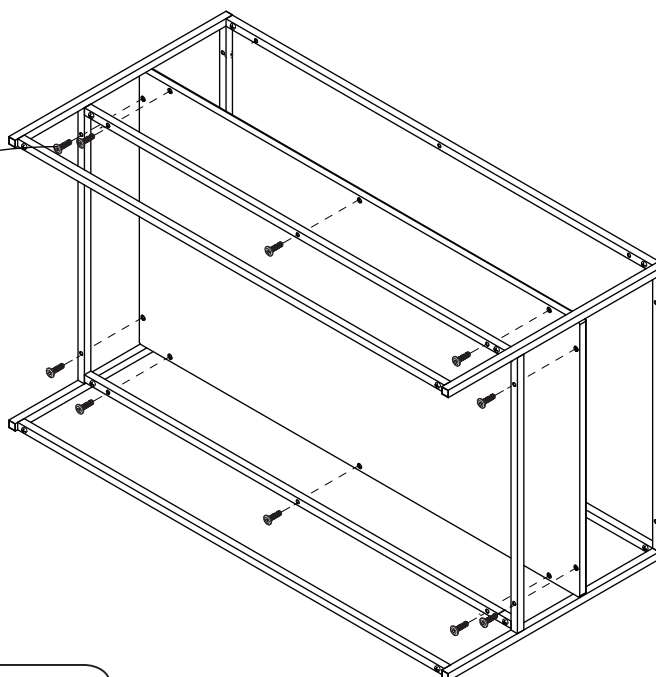
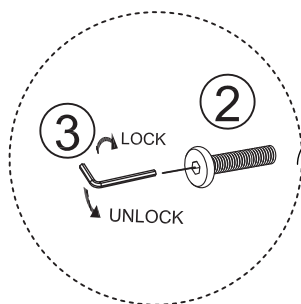

Step 5

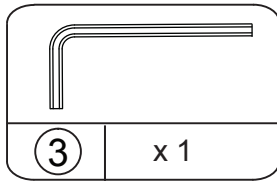
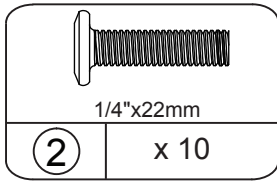
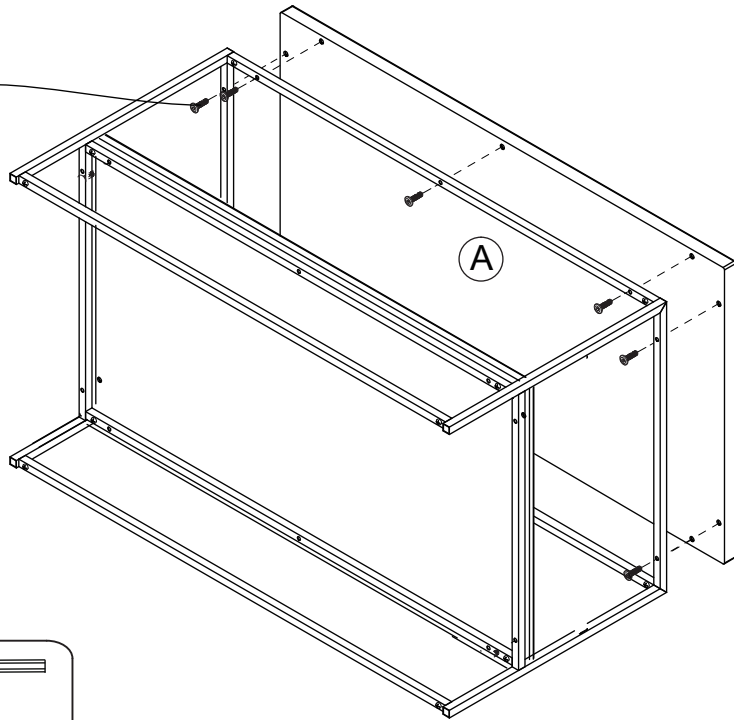
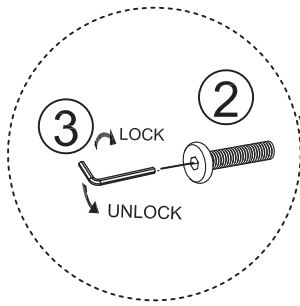

Safety Maximum Loads

This unit has been designed to support the maximum loads shown. Exceeding these load limits could cause sagging, instability, product collapse, and/or serious injury.

