

This instruction manual is the final and revised version.

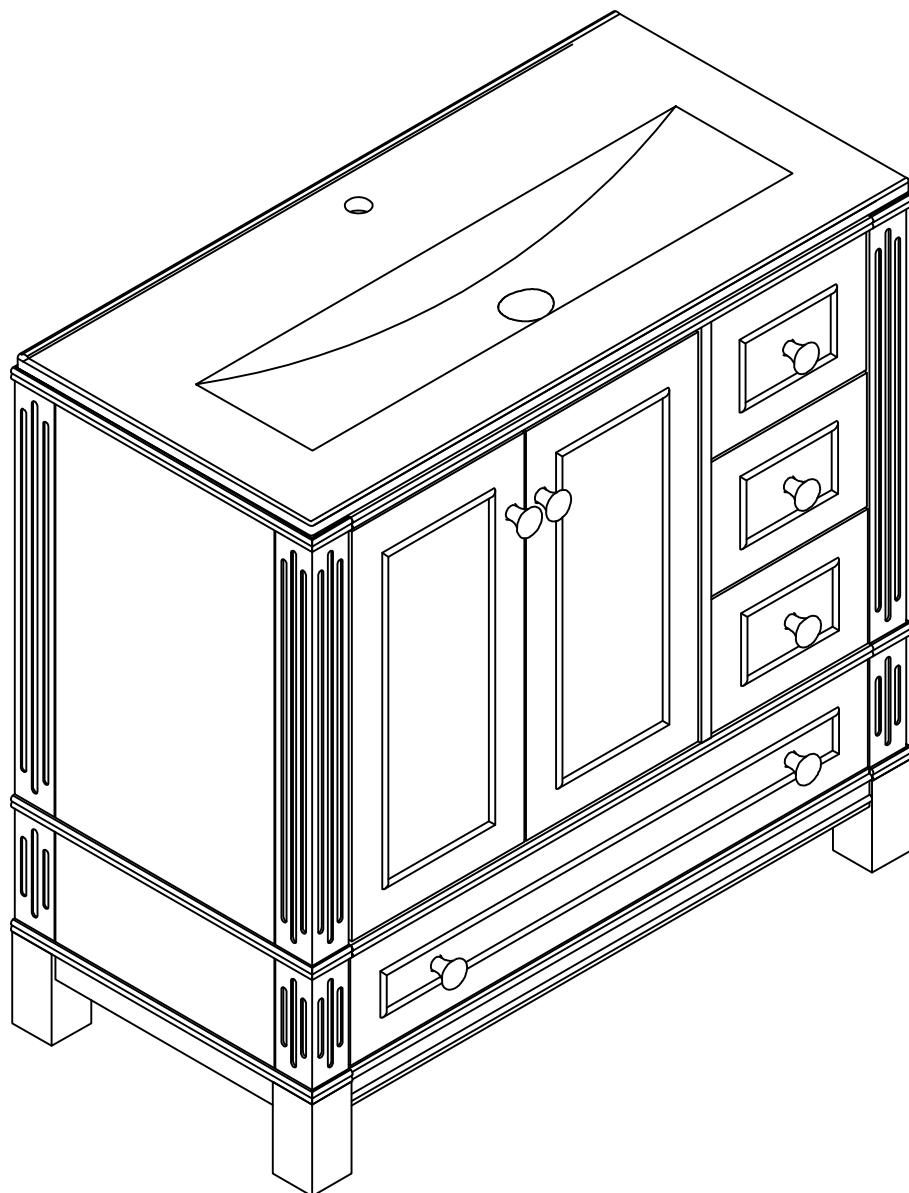

DURA36KDCM INSTALLATION INSTRUCTIONS

If any questions ,please feel free to call or text us at +16267081381,
or Email us at cabinetservice25@outlook.com.

DIMENSIONS

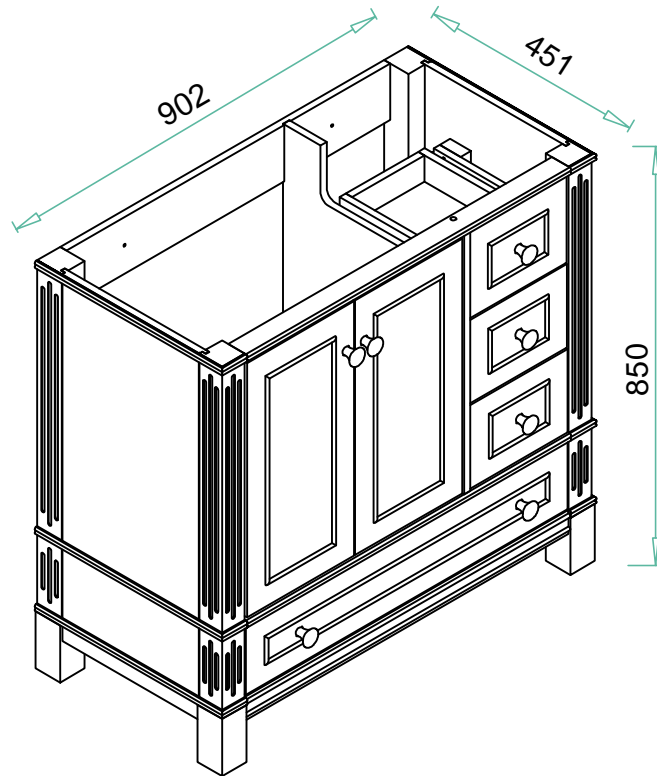





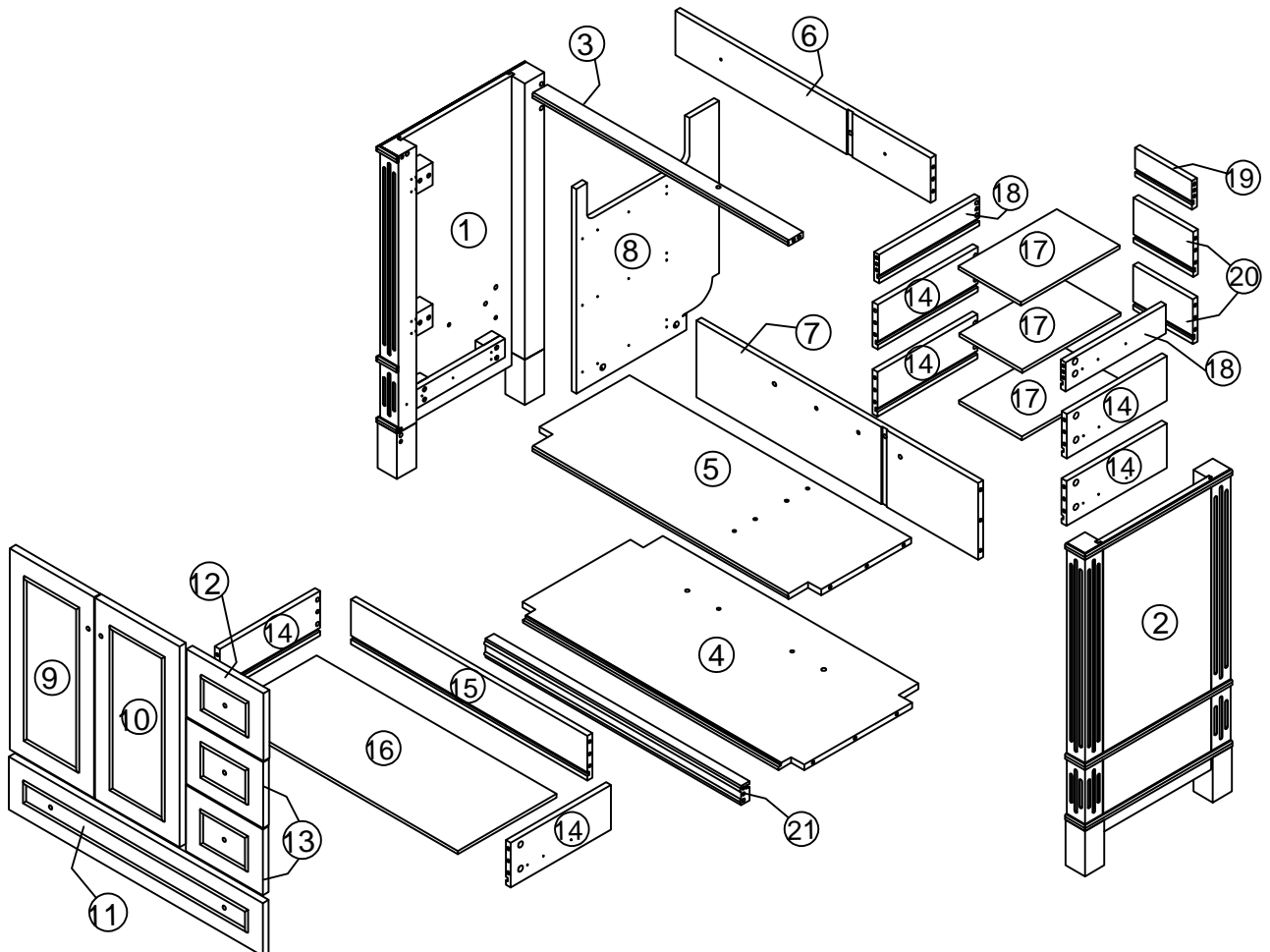



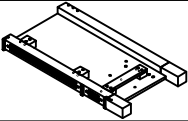
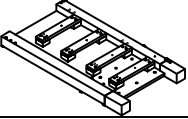
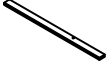

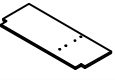
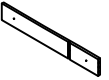
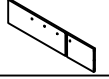



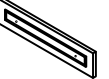











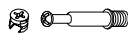

Unit: mm

ASSEMBLY DIAGRAM

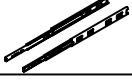

PARTS LIST

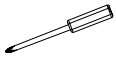
PARTS LIST		
No	Description	Qty
1		1
2		1
3		1
4		1
5		1
6		1
7		1
8		1
9		1
10		1
11		1
12		1
13		2
14		6
15		1
16		1
17		3
18		2
19		1
20		2
21		1

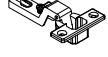
PARTS LIST		
No	Description	Qty
A	 Three-in-one Connector	58
B	 Handle	7
C	 Handle Screws M4x15	5
D	 Handle Screws M4x22	2
E	 Medium Curved Hinge	2
F	 Screws M3.5x15	24
G	 The slides	8
H	 Screws M3x12	64
I	 Wood Plug	43
J	 Screws For Fix On The Wall	2
K	 Screws M4x25	3
L	 Screwdriver	1
M	 Double-sided tape	1
N	 Highly Curved Hinge	2

THE SLIDE

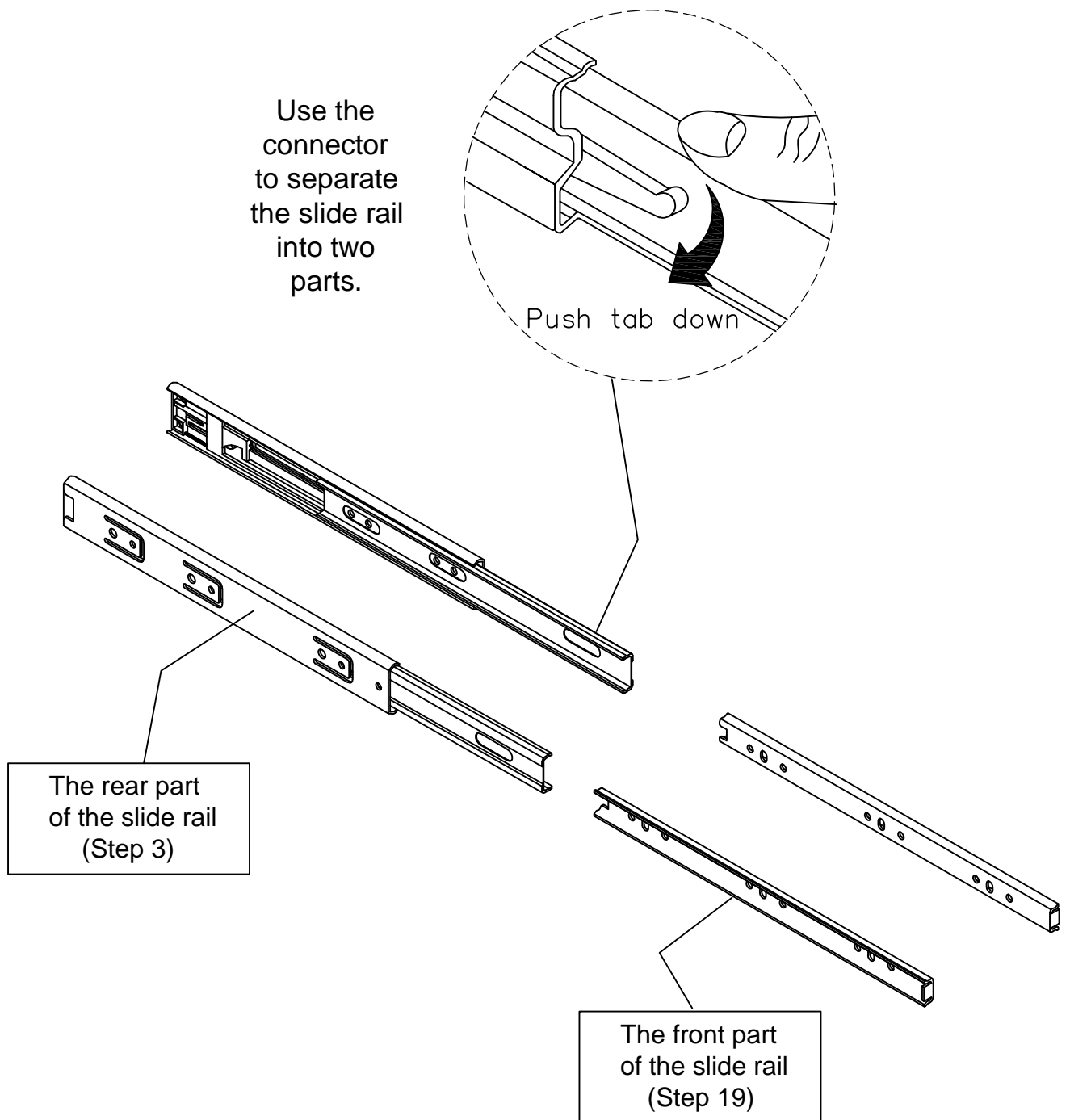

- Use the connector to separate the slide rail into two parts.
- The front part of the slide rail is attached to both side panels of the drawer using screws in the pre-drilled positioning holes (Step 3)
- While the rear part of the slide rail is attached to both side panels of the cabinet using screws in the pre-drilled positioning holes (Step 19)

YOU MAY NEED (NOT SUPPLIED)

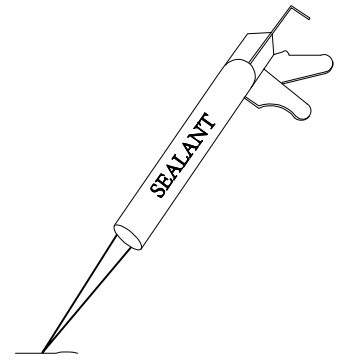
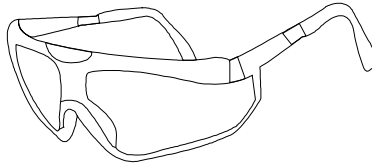
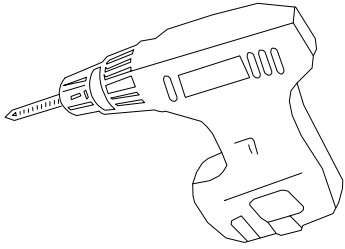

INSTALLATIONS

STEP 1

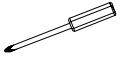
HARDWARE LIST	
A  26 PCS	

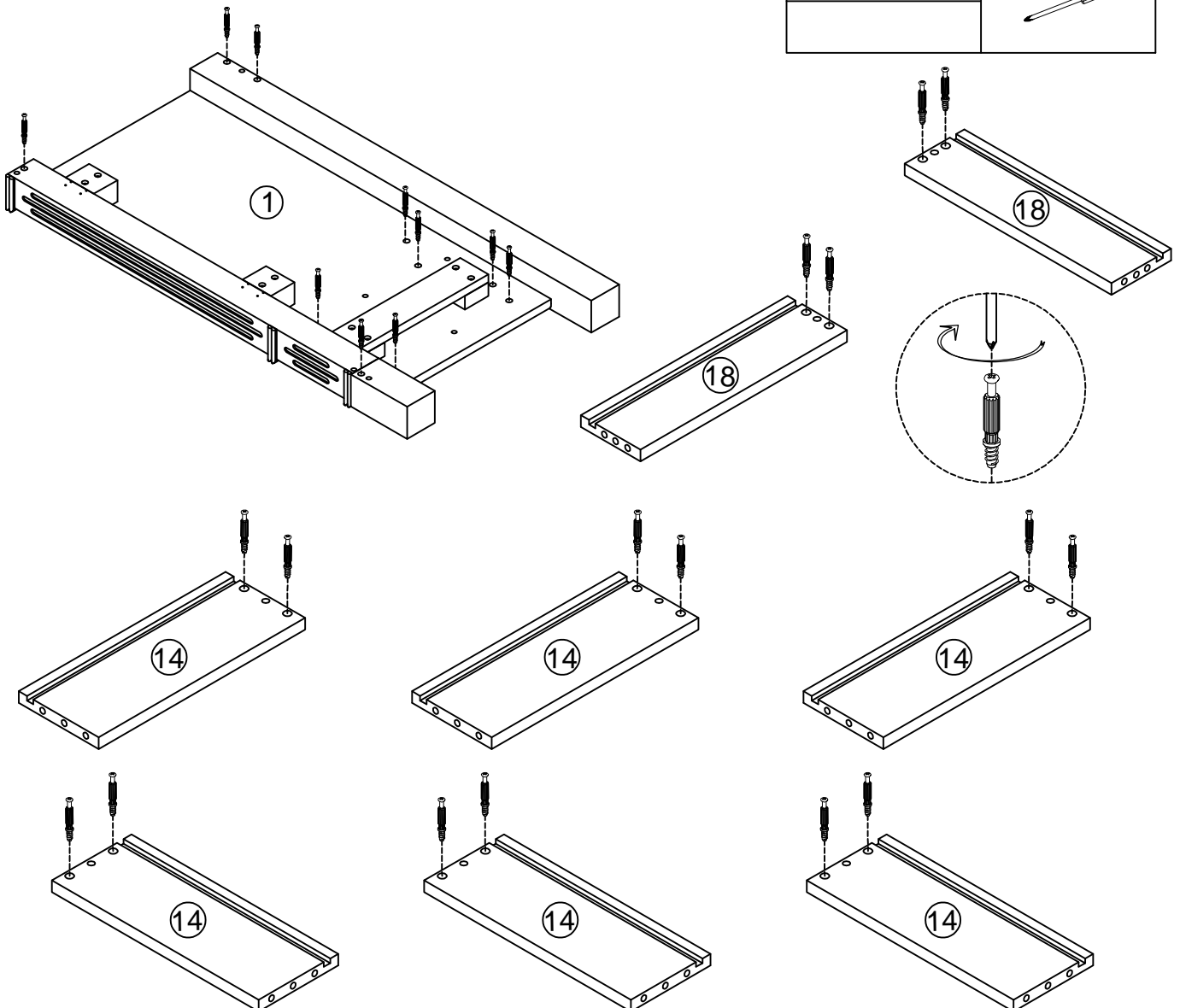

○ Insert the Cam Screw into the shelves above

STEP 2

HARDWARE LIST

A  32 PCS

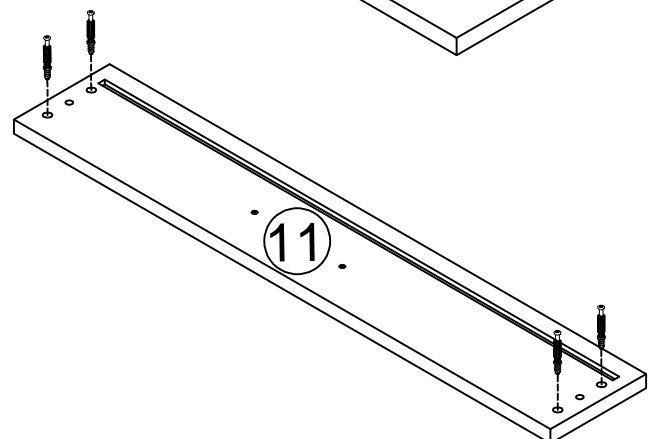
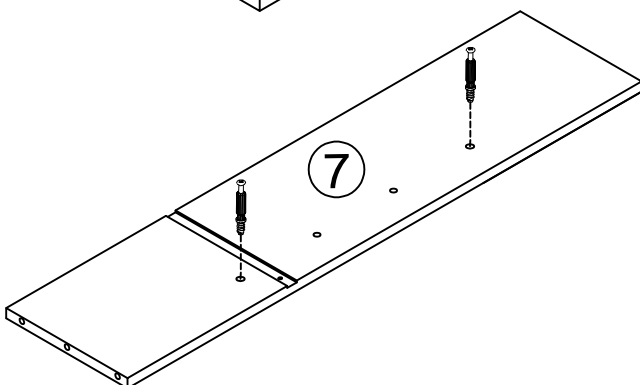
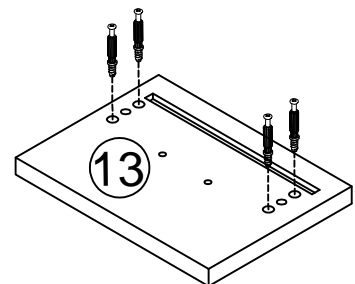
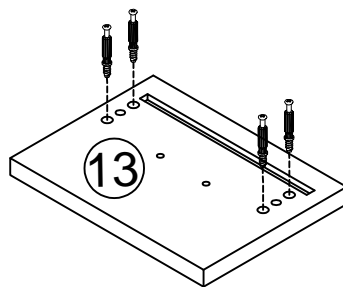
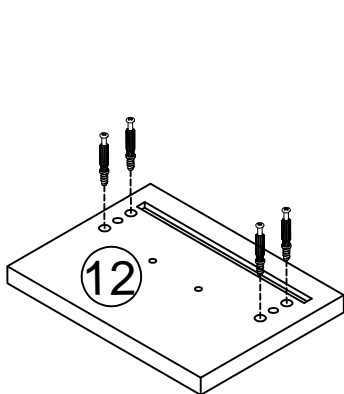
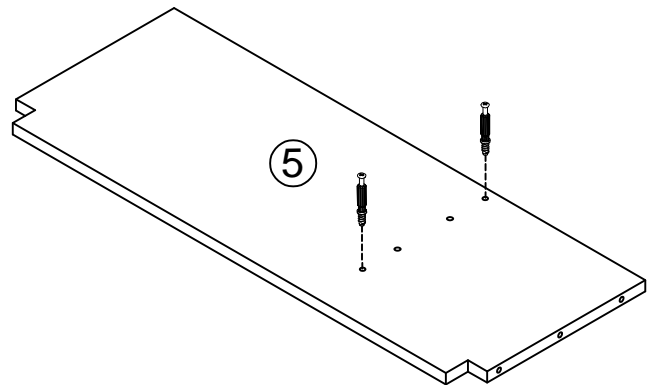
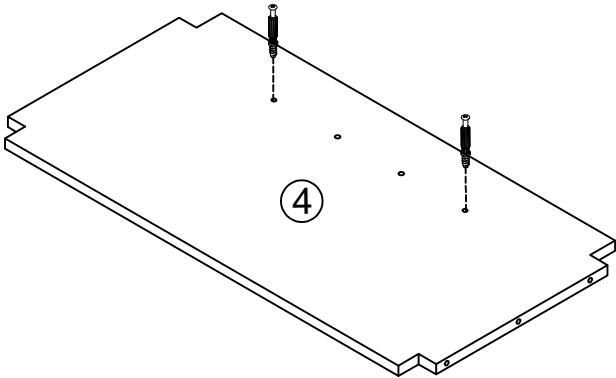
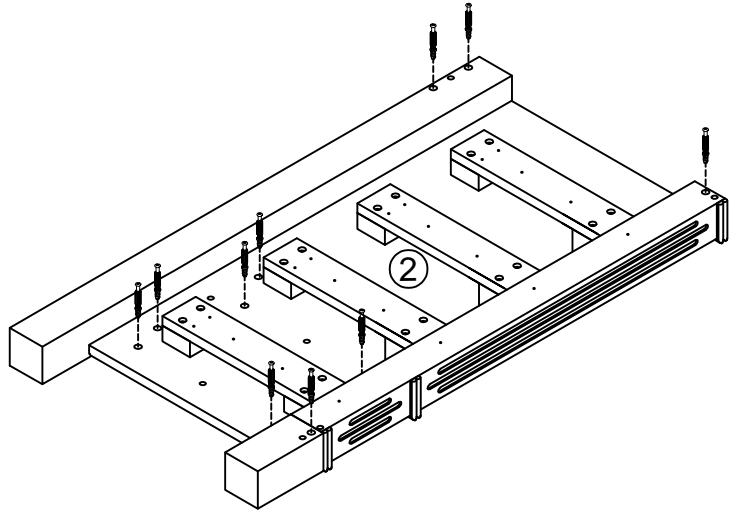
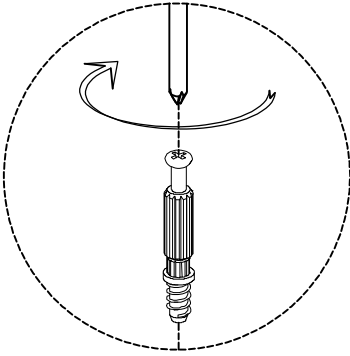
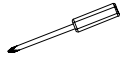

○ Insert the Cam Screw into the shelves above

STEP 3

HARDWARE LIST

G  8 PCS

H  40 PCS

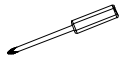

The rear part
of the slide rail

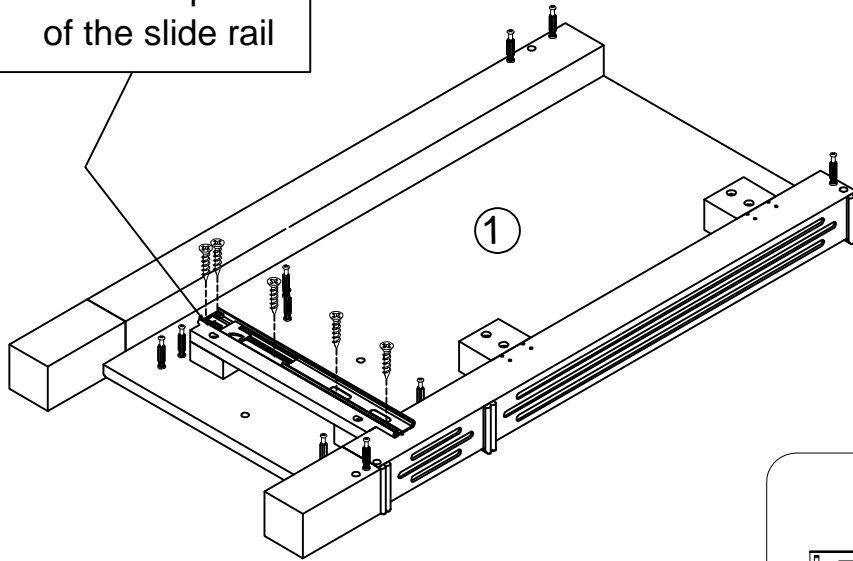

The rear part
of the slide rail

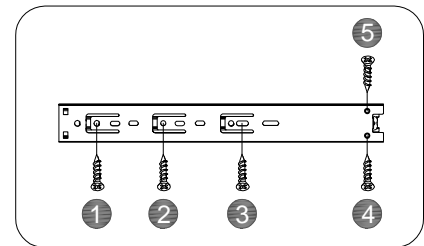
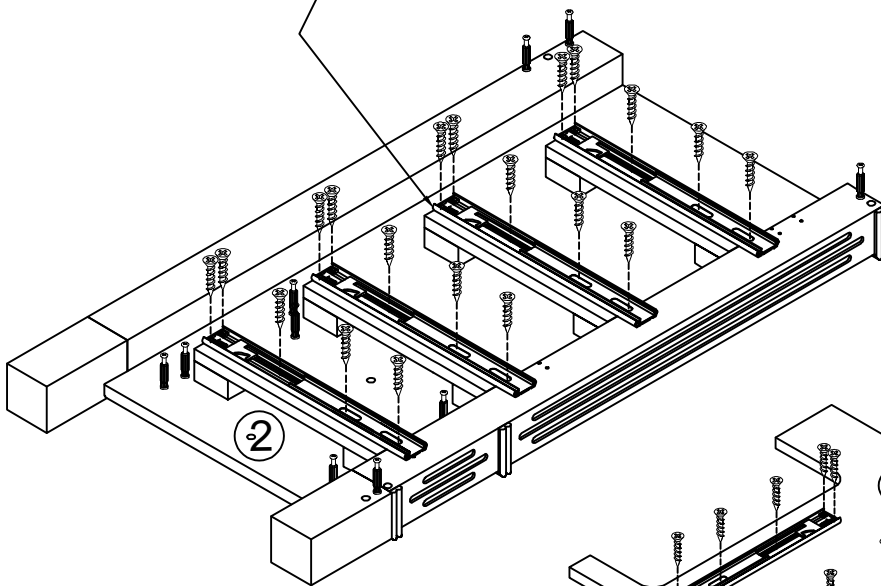

The rear part
of the slide rail

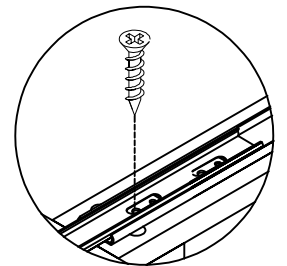

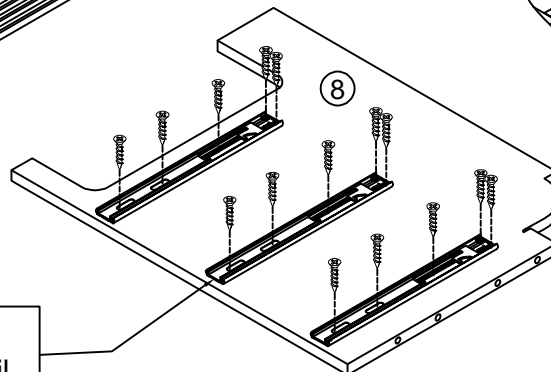

The rear part
of the slide rail



- While the rear part of the slide rail is attached to both side panels of the cabinet using screws in the pre-drilled positioning holes

STEP 4

HARDWARE LIST	
 43 PCS	

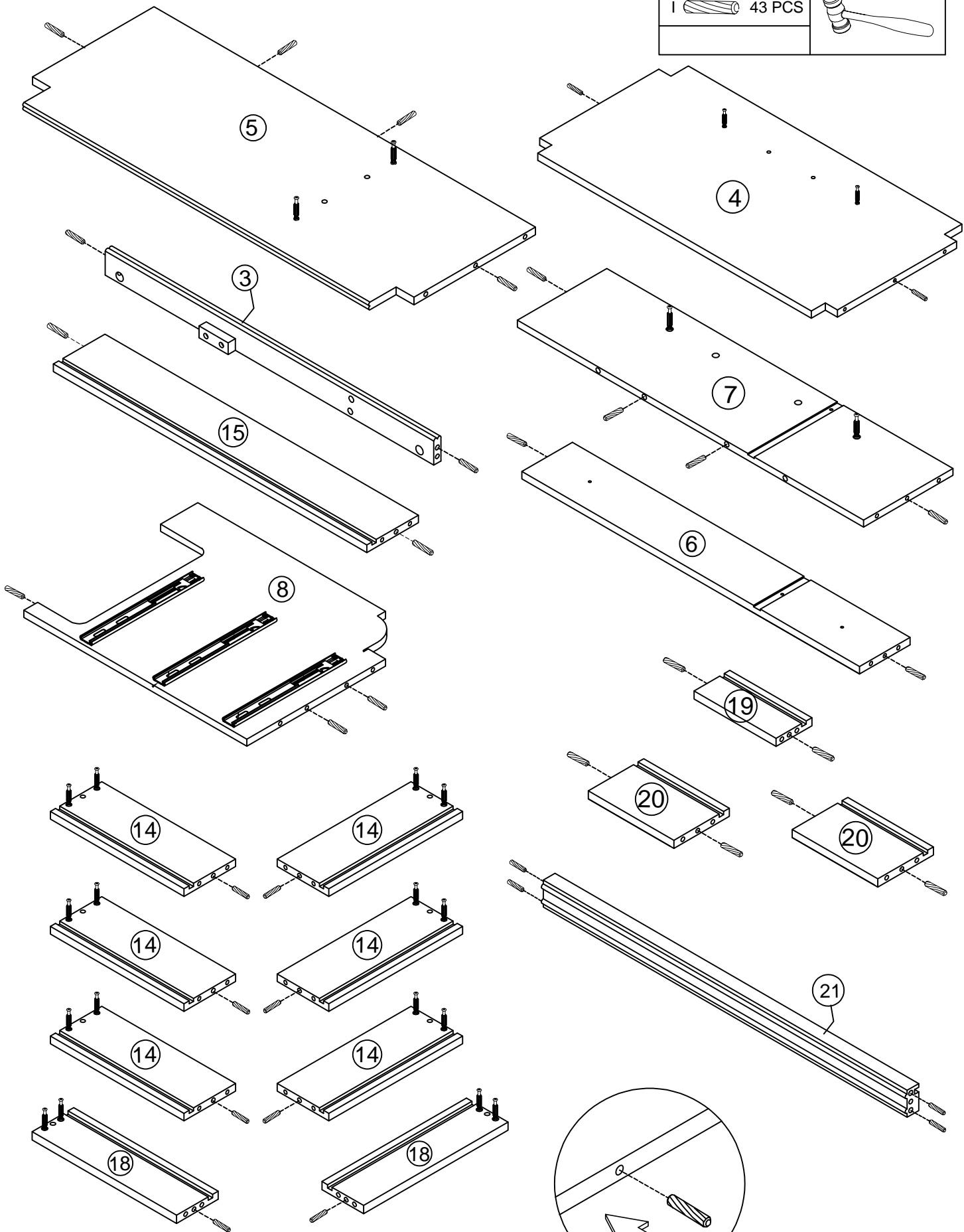

○ Insert the wooden dowel pins into the shelves

STEP 5

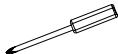
HARDWARE LIST	
A  2 PCS	

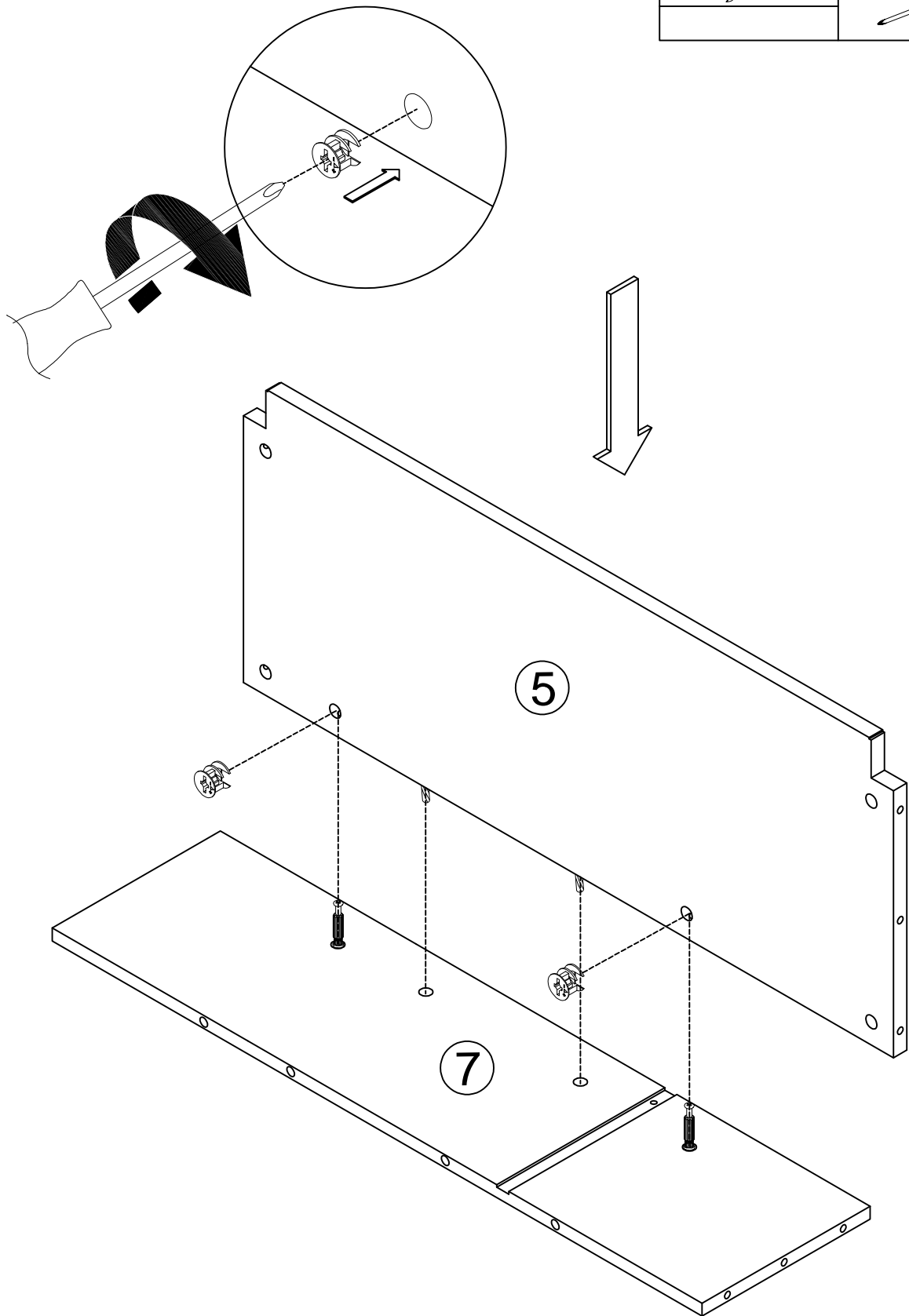

◦ Refer to the illustration, already assembled #7 on the shelf #5. Then tighten the cam lock

STEP 6

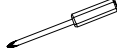
HARDWARE LIST	
A	 2 PCS
	

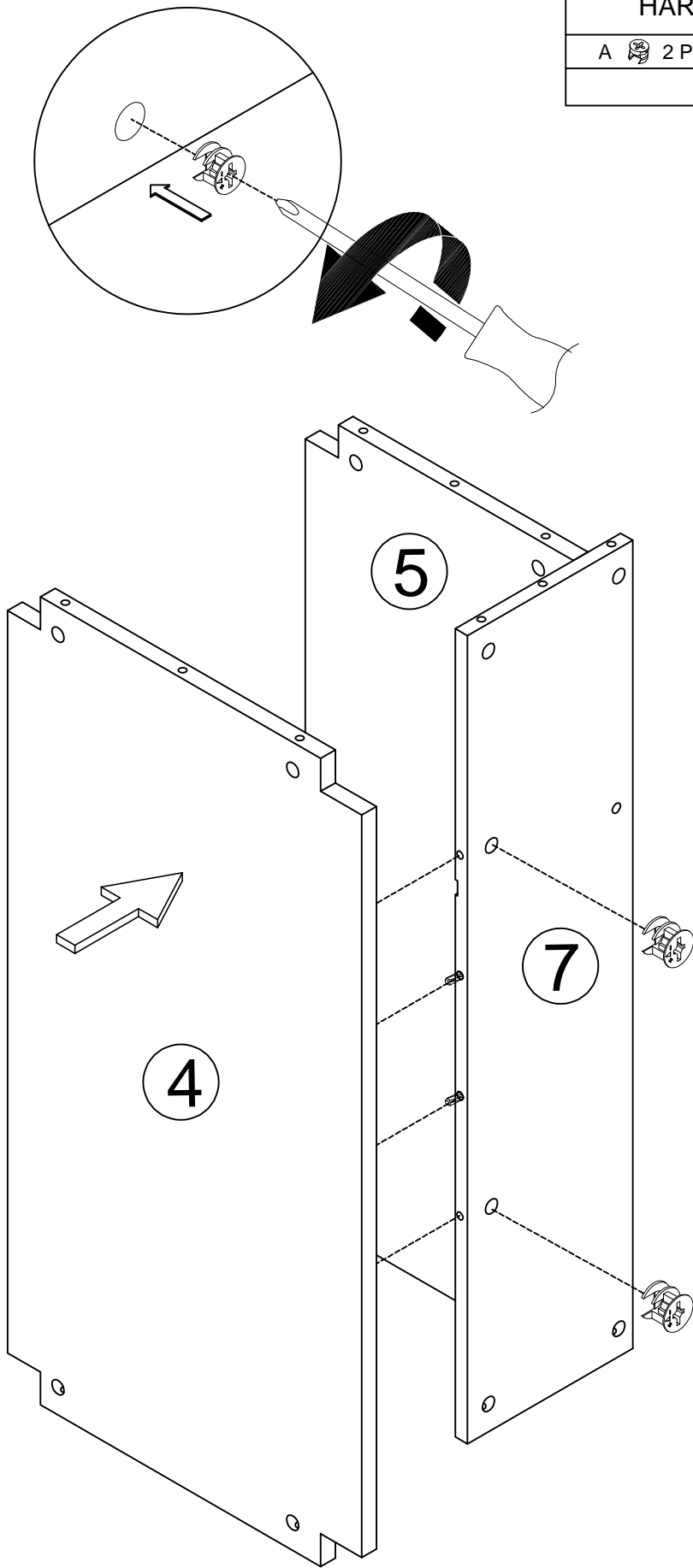

○ Refer to the illustration, already assembled #4, #23 on the shelf #7. Then tighten the cam lock

STEP 7

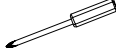
HARDWARE LIST	
A	 2 PCS
	

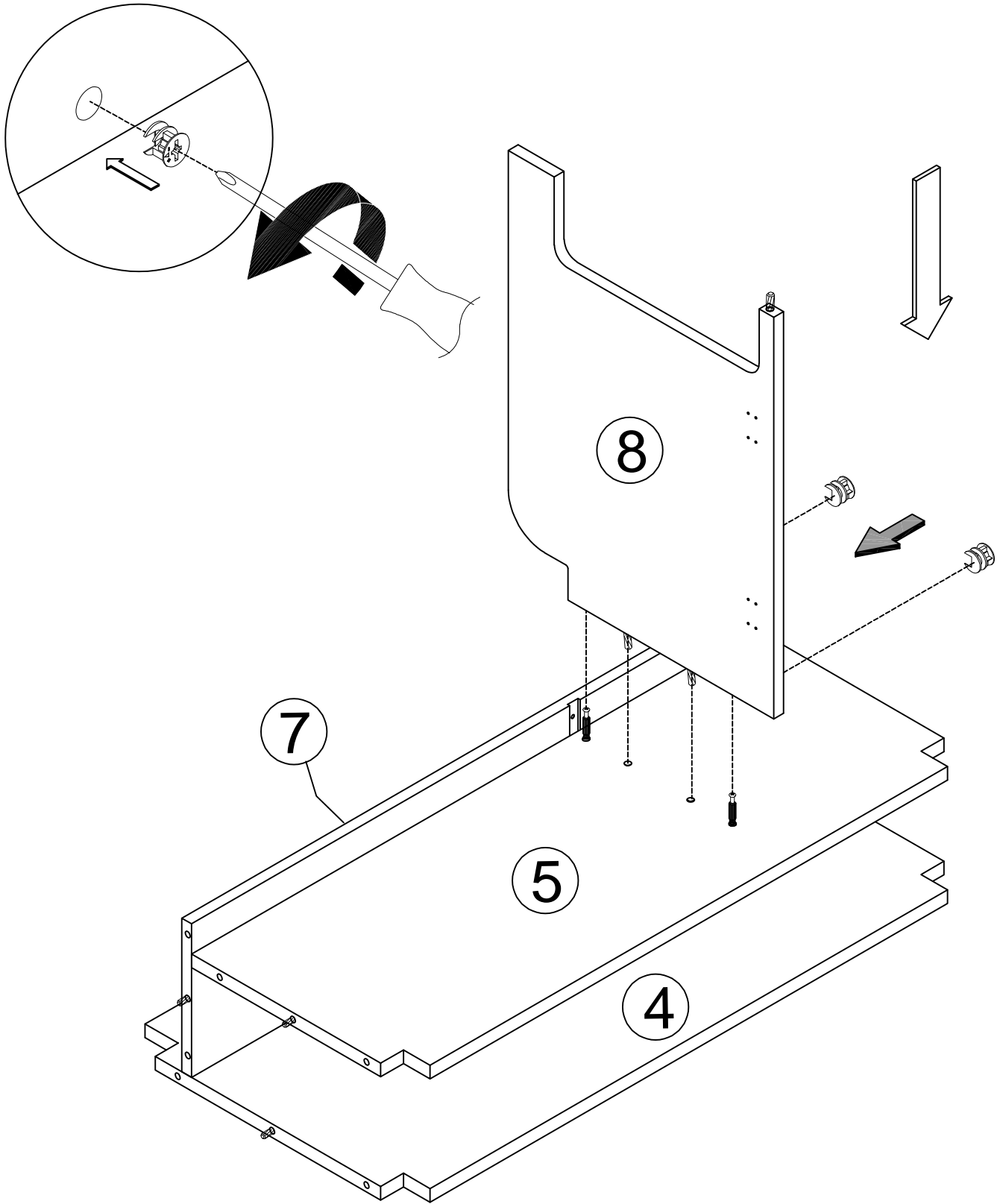

○ Refer to the illustration, already assembled #8 on the shelf #5. Then tighten the cam lock

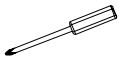

STEP 7

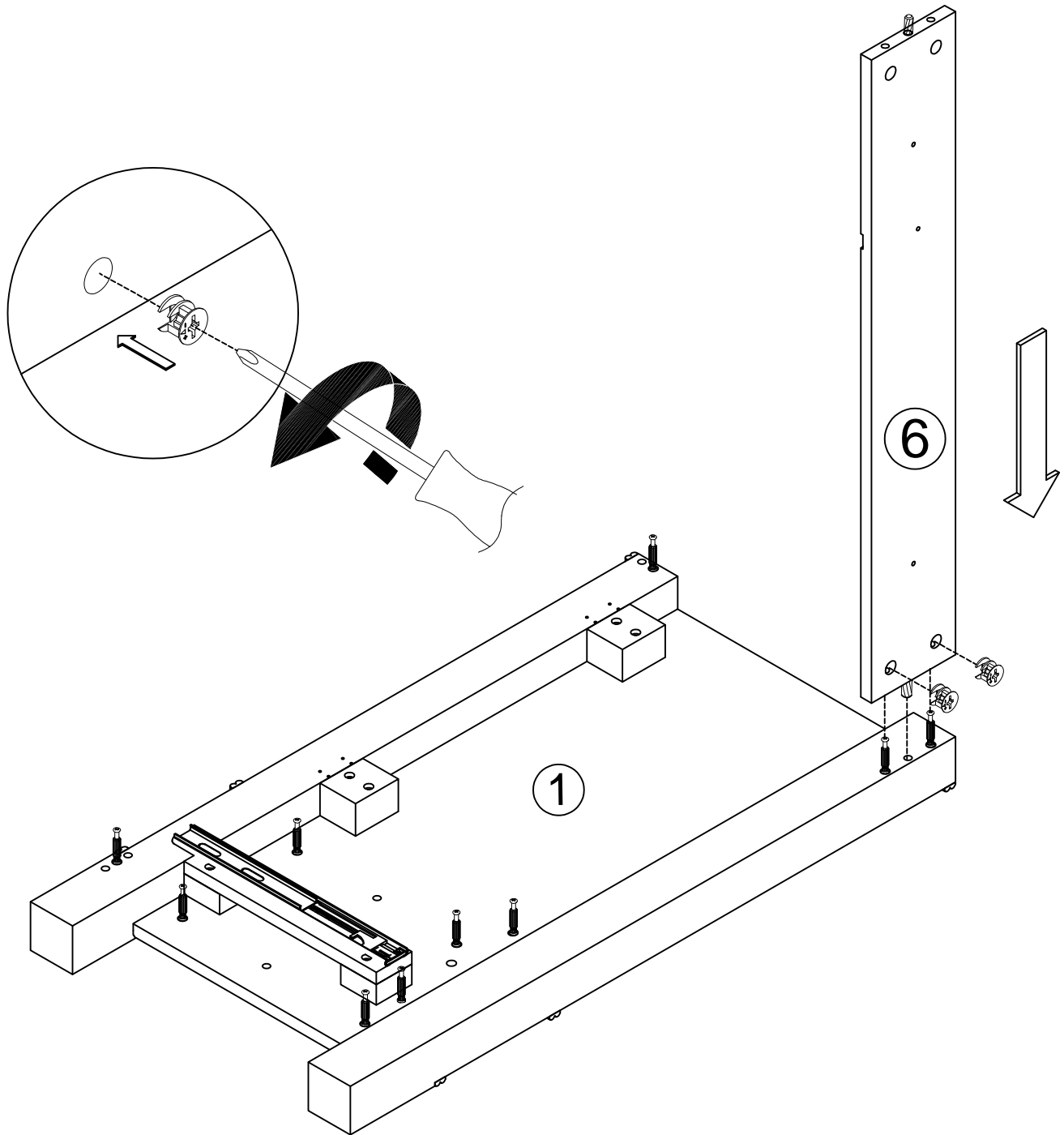
HARDWARE LIST	
A	 2 PCS
	



- Refer to the illustration, already assembled #6 on the side panel. #1. Then tighten the cam lock

STEP 8

HARDWARE LIST	
A	 7 PCS
	

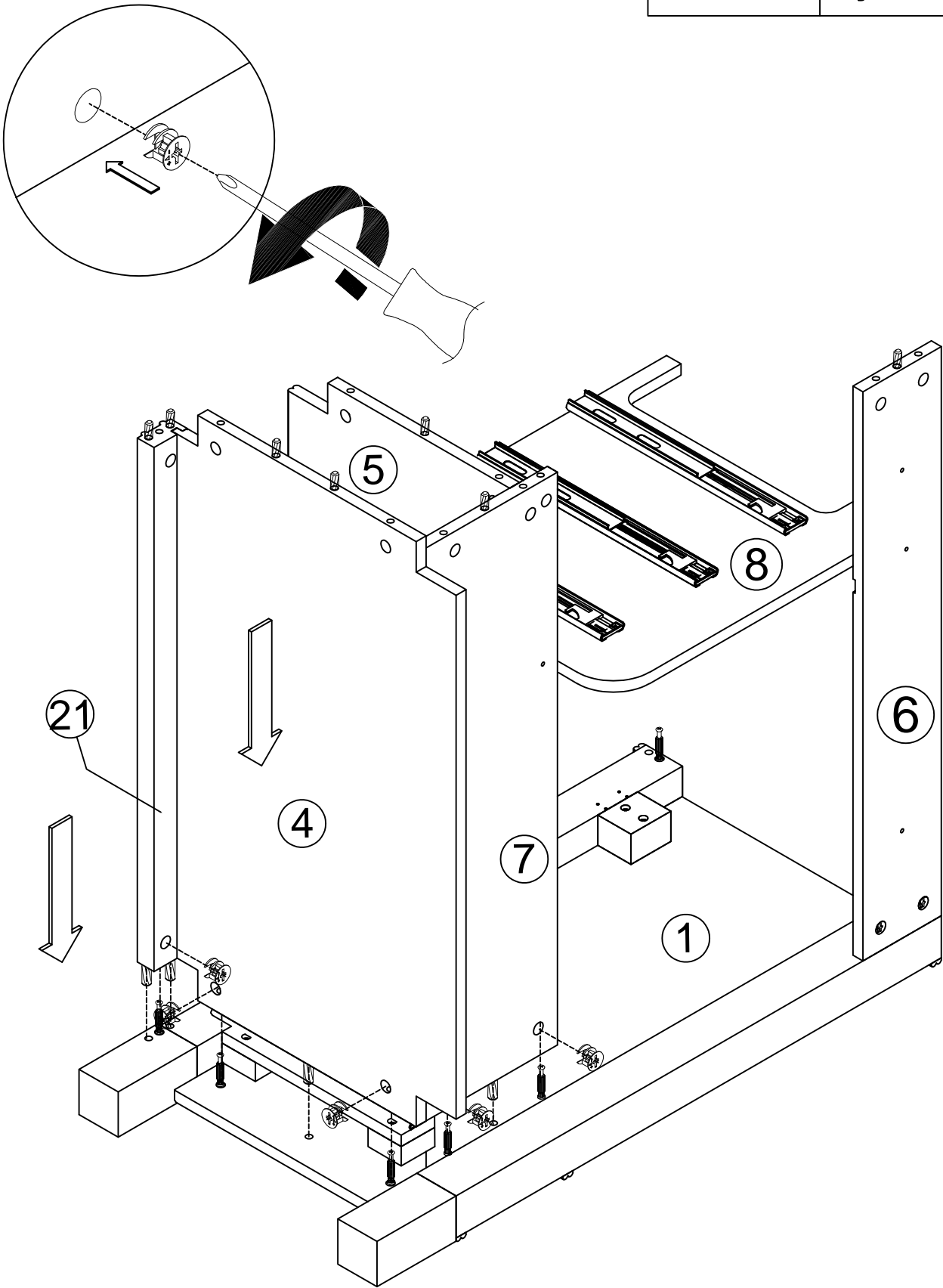

○ Refer to the illustration, already assembled #4, #5, #7, #8, #21 on the side panel. #1.
Then tighten the cam lock

STEP 9

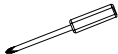
HARDWARE LIST	
A	 1 PCS
	

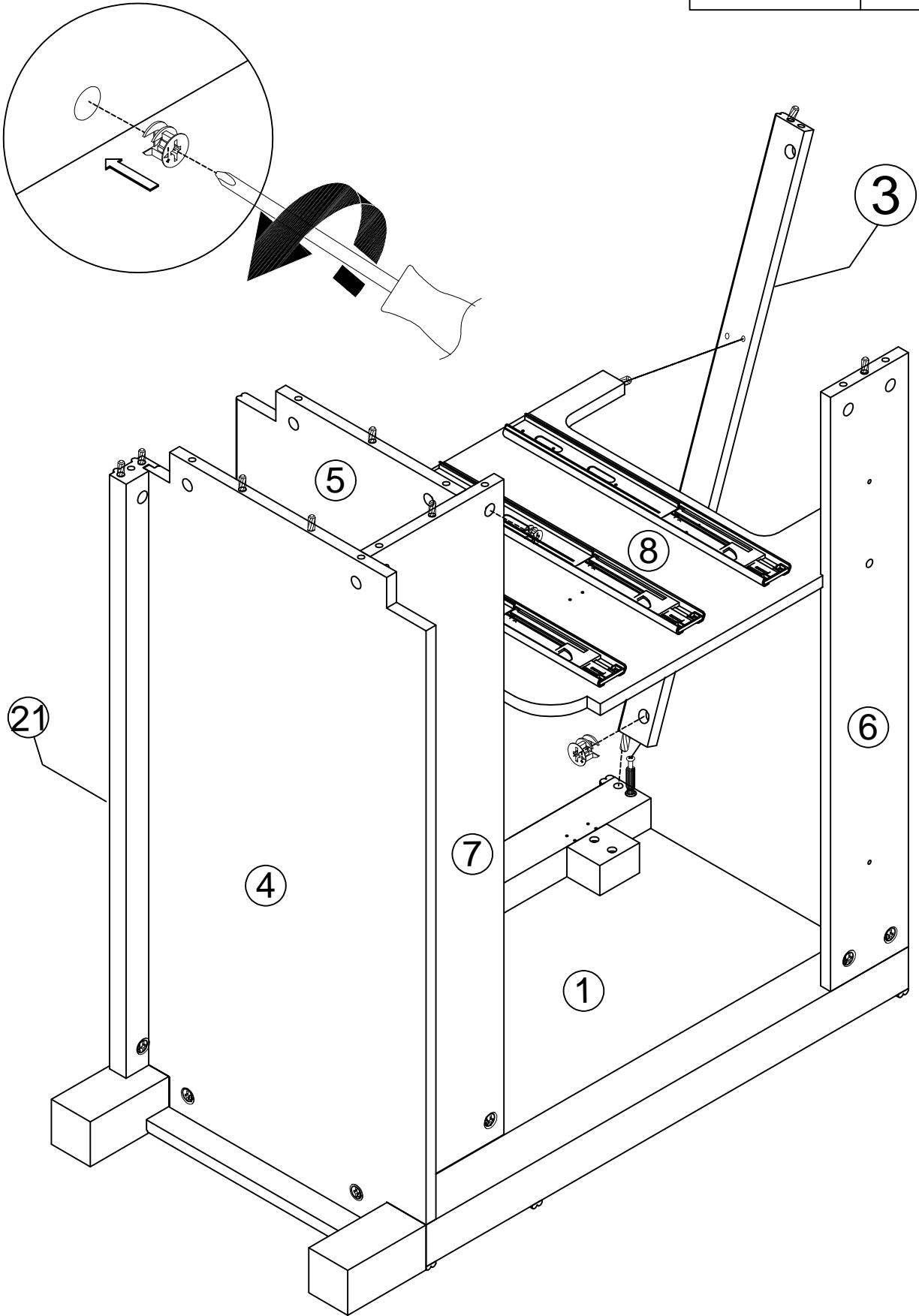

○ Refer to the illustration, already assembled #3 on the side panel #1. Then tighten the cam lock

STEP 10

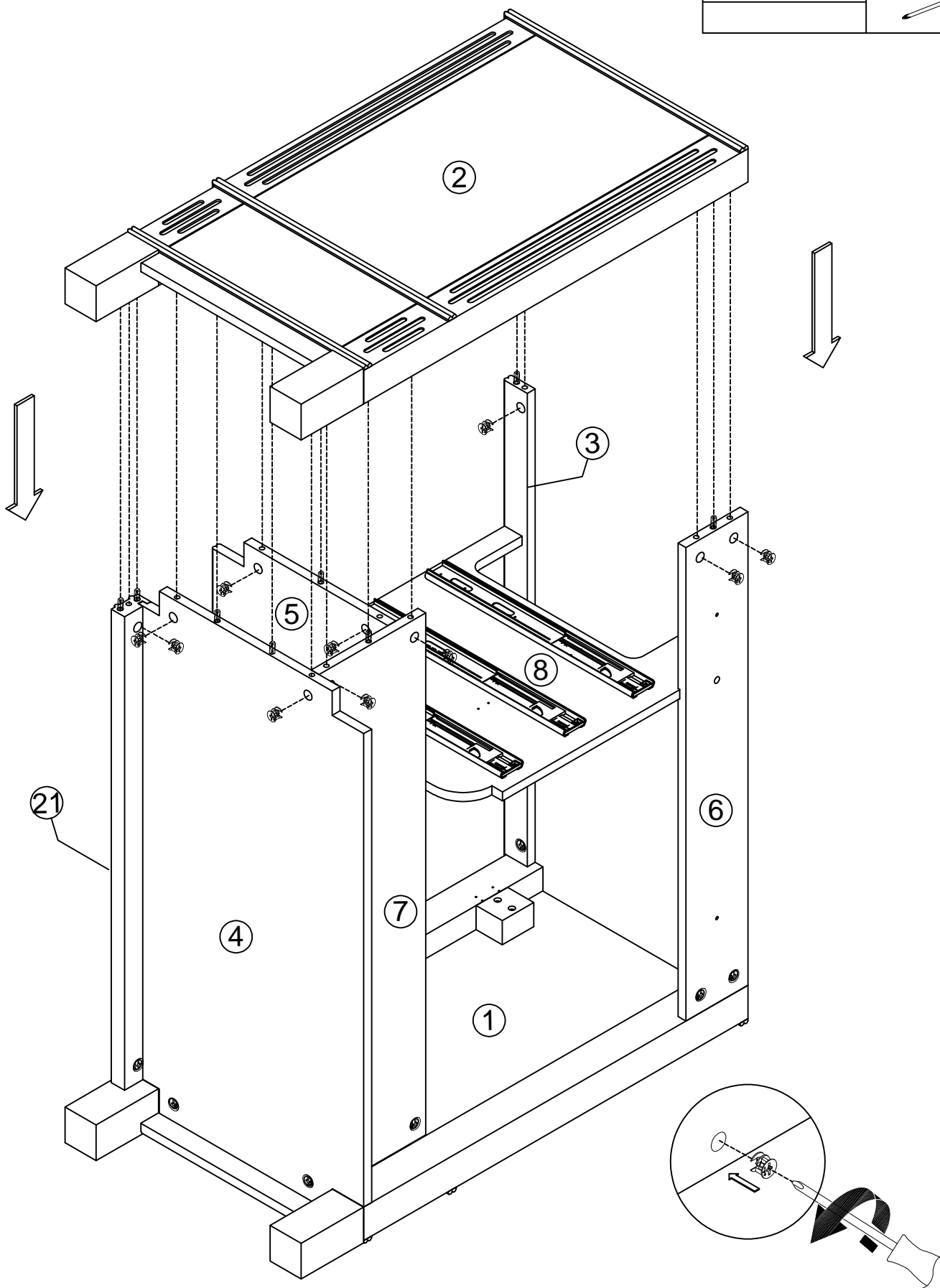
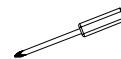

HARDWARE LIST

A  10 PCS



- Refer to the illustration, already assembled side panel #2 on the side sheft #5, #7, #4, #8, #3, #6 . Then tighten the cam lock



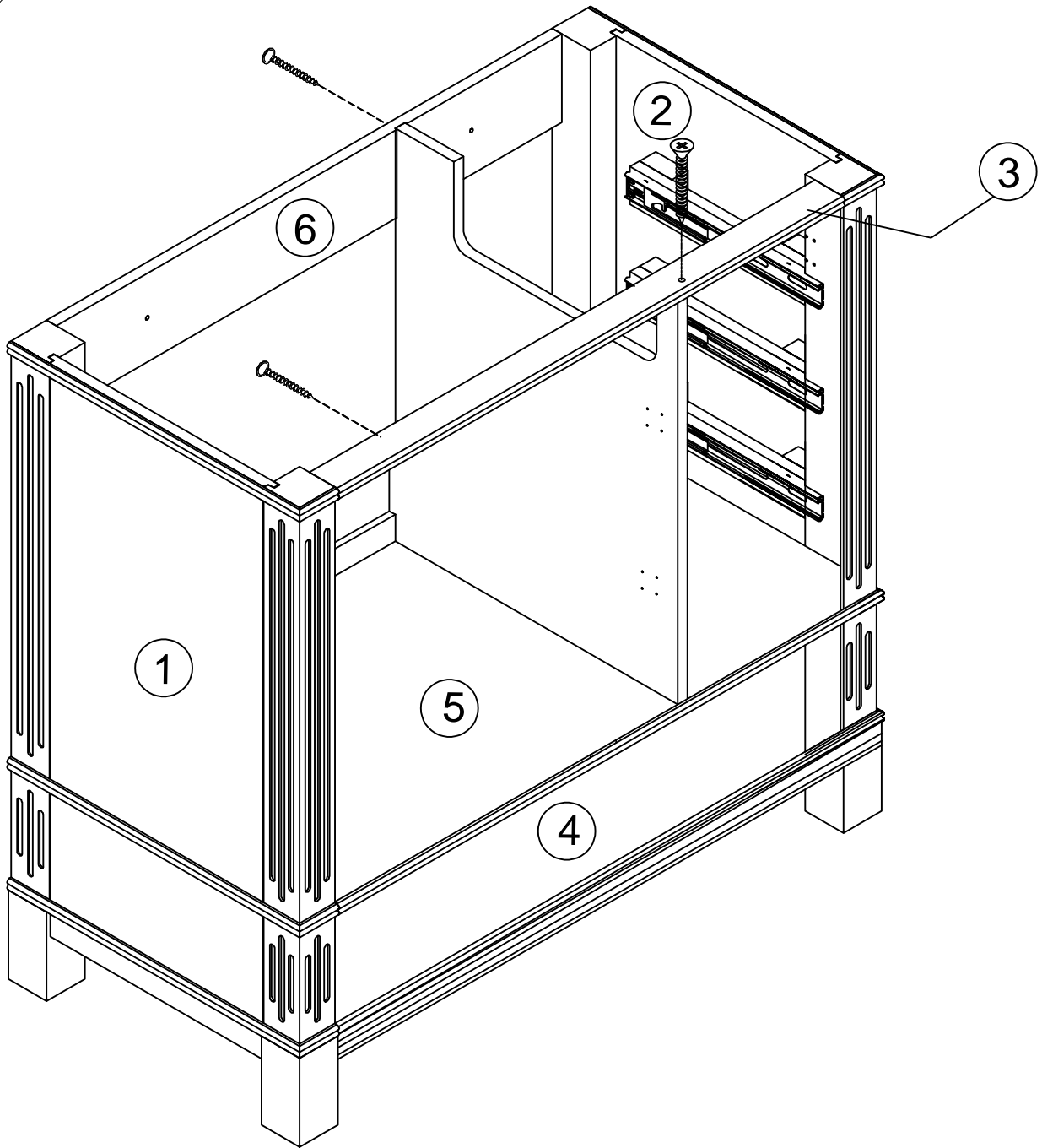
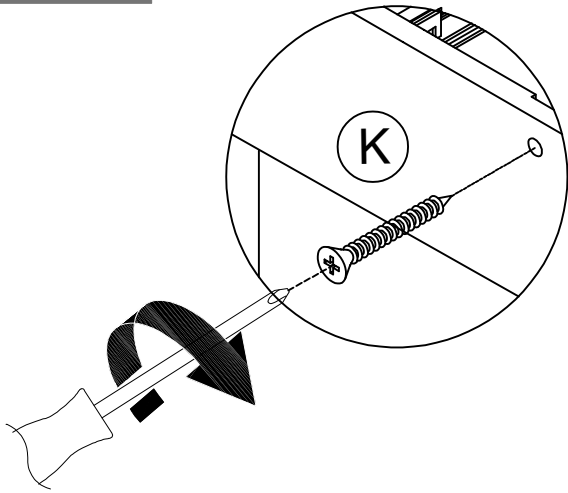

STEP 11

HARDWARE LIST	
K	 3 PCS
	



○ Use screws to fasten from back to front.

STEP 12

HARDWARE LIST	
E	2 PCS 
F	8 PCS 
B	2 PCS 
D	2 PCS 
N	2 PCS 

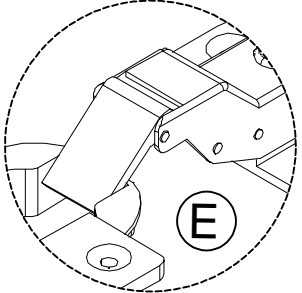
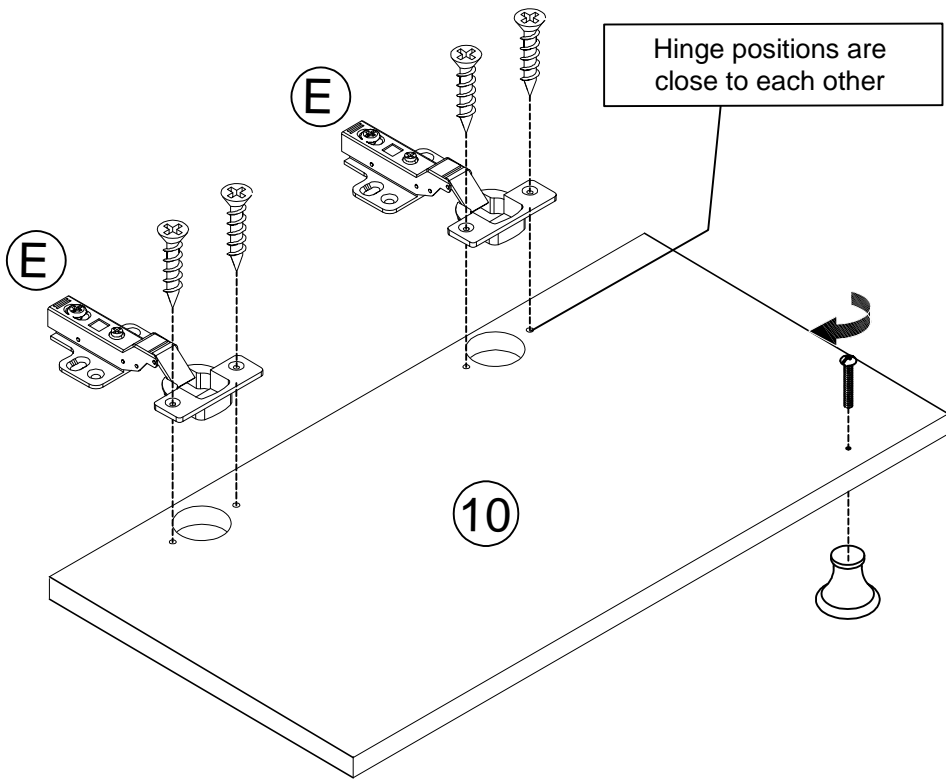
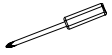

Medium Curved Hinge

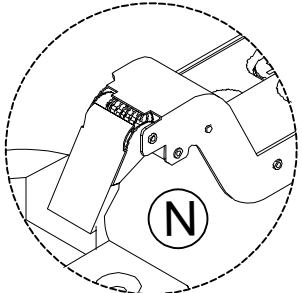
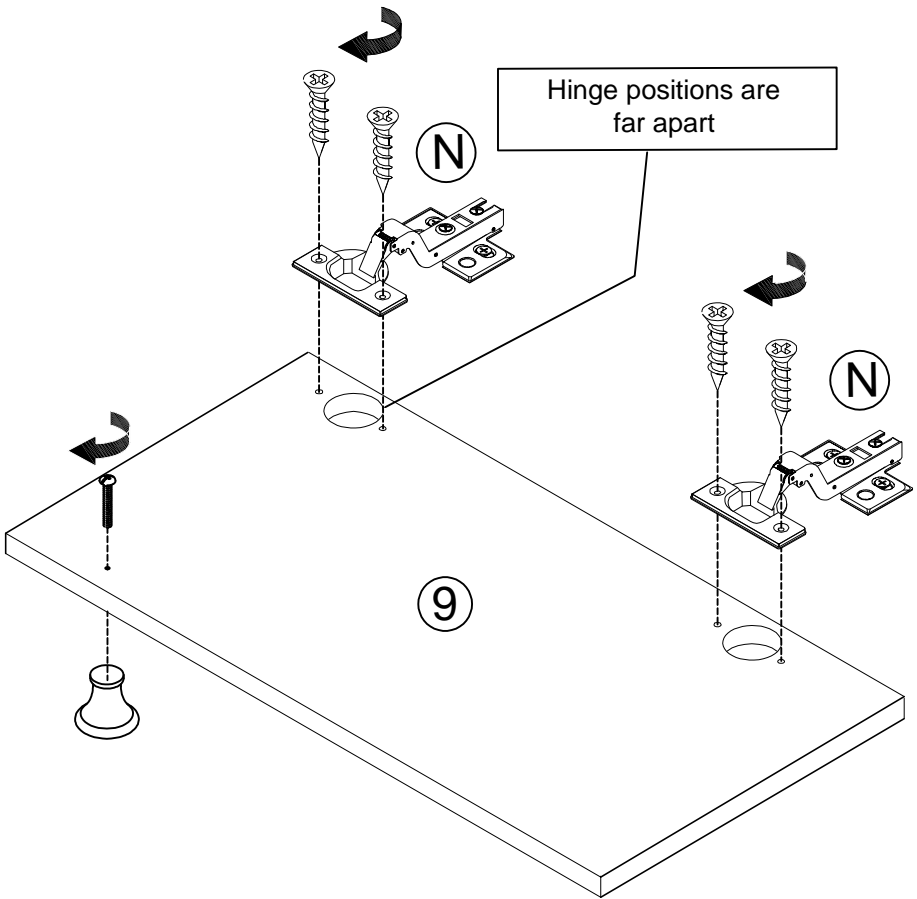

Highly Curved Hinge

○ Use Screws to install the handle and apply Screws to fix the hinge on the shelf #9 and #10

STEP 13

HARDWARE LIST

F  8 PCS

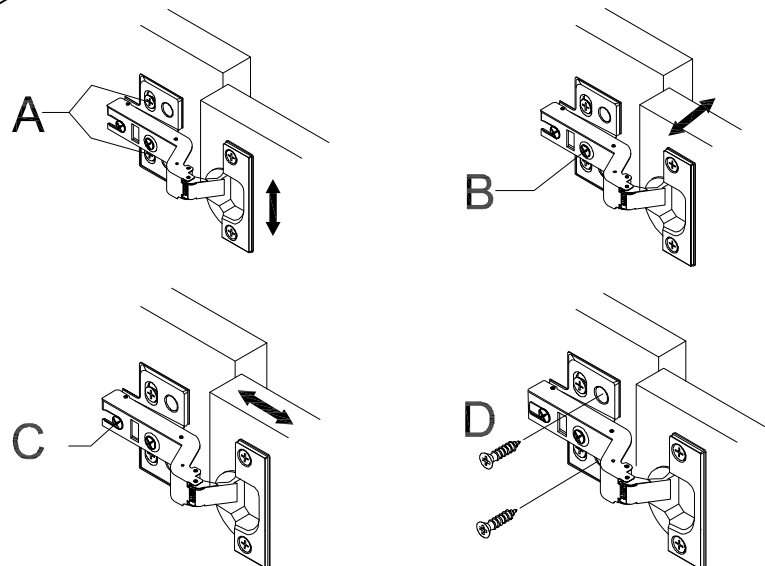
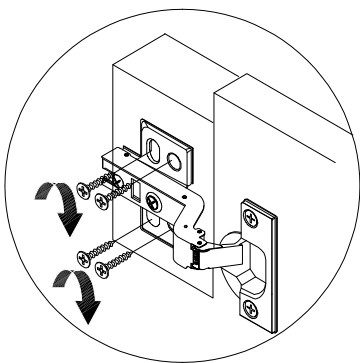
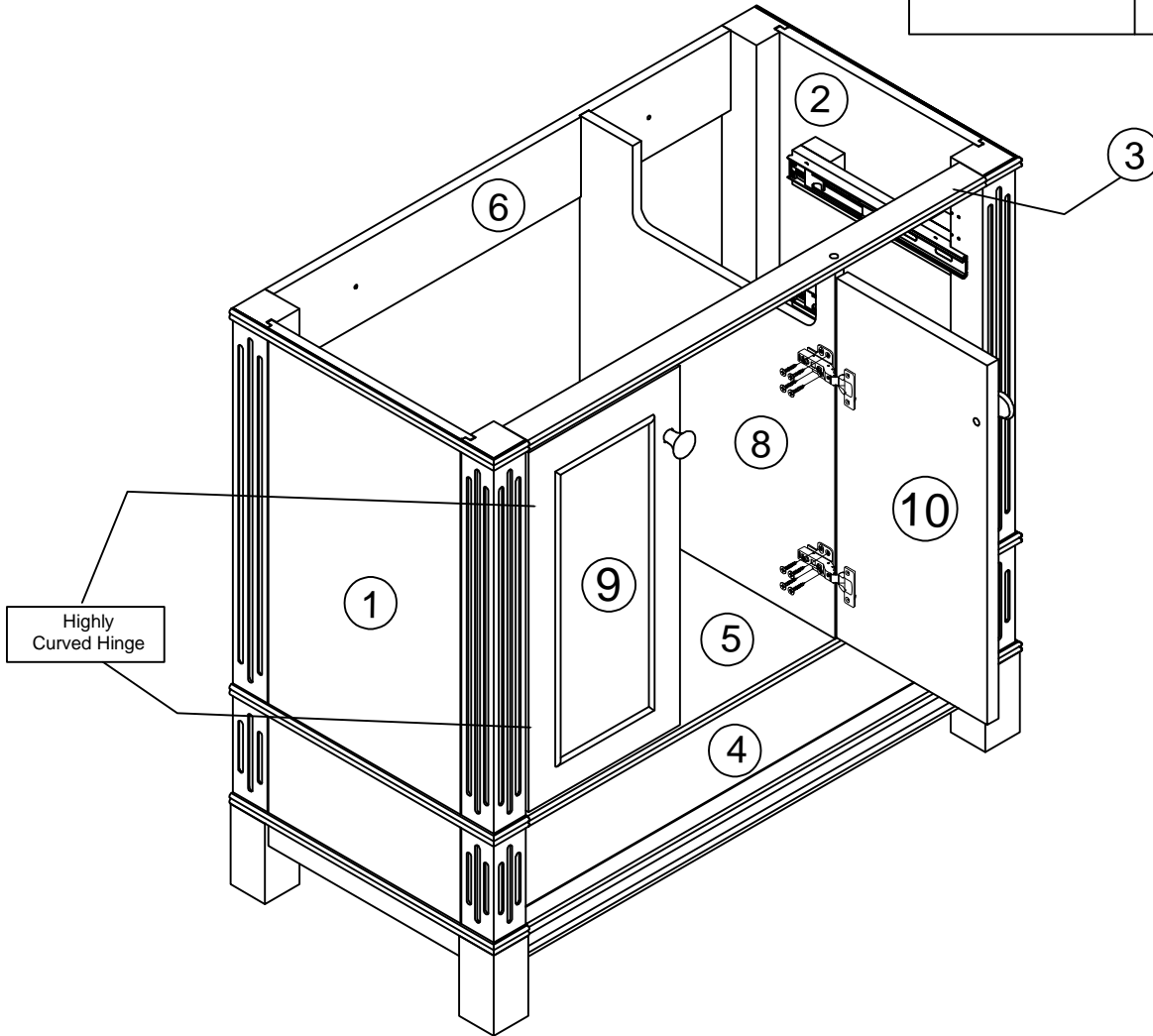
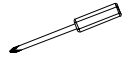

A. Height adjustment
C. Depth adjustment

B. Side to side adjustment
D. After adjustment A/B/C, tighten screws

- Install the door on the cabinet; Door #10 uses a "Highly Curved Hinge", installed on the left side of the cabinet
- To ensure proper cabinet alignment, refer to the above illustrations for instructions about adjusting the cabinet height, depth and lateral movement

STEP 14

HARDWARE LIST

F  8 PCS

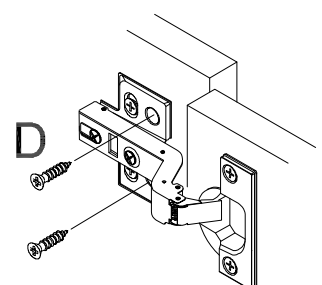
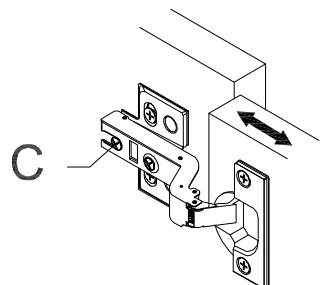
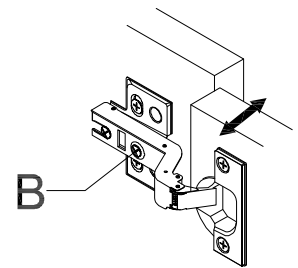
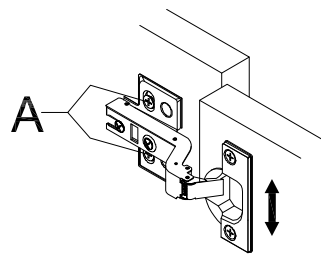
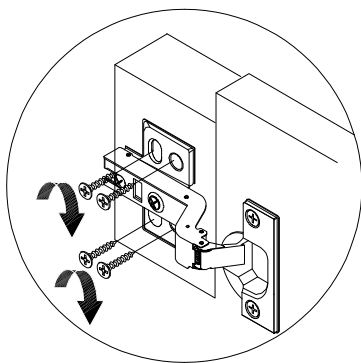
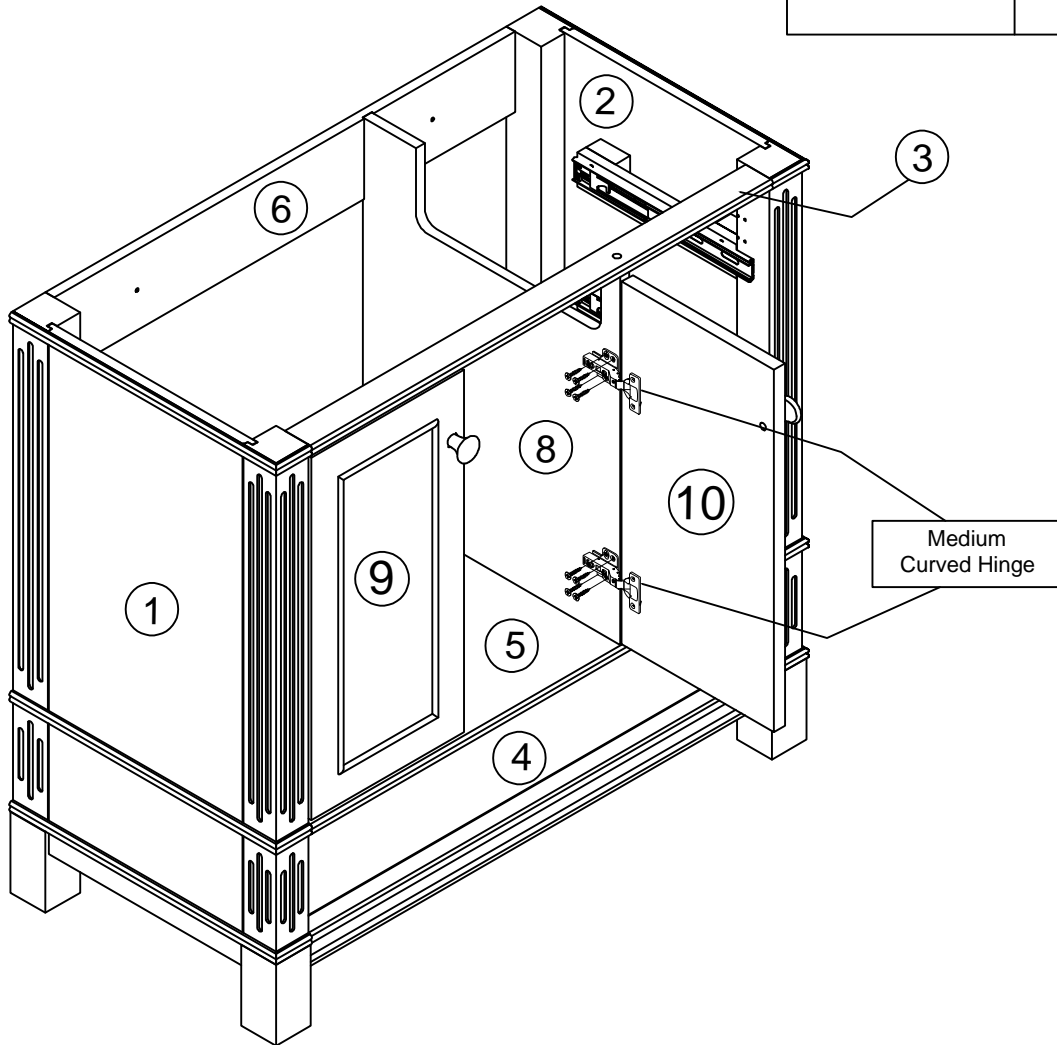
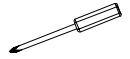

A. Height adjustment
C. Depth adjustment

B. Side to side adjustment
D. After adjustment A/B/C, tighten screws

- Install the door on the cabinet; Door #9 uses a "Medium Curved Hinge", installed on the right side of the cabinet
- To ensure proper cabinet alignment, refer to the above illustrations for instructions about adjusting the cabinet height, depth and lateral movement

STEP 15

HARDWARE LIST

A  8 PCS

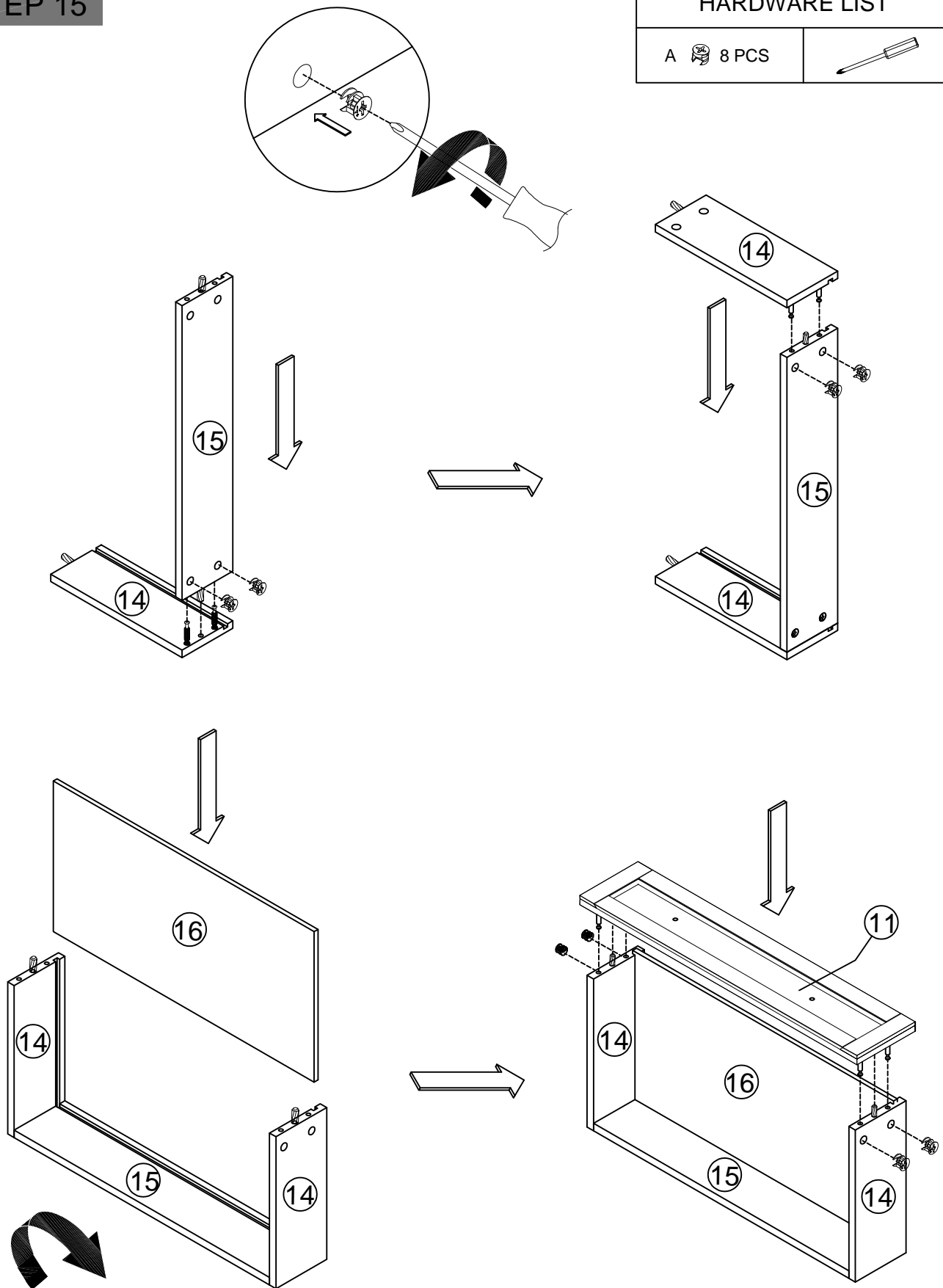
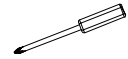

- The side panels of drawer #14 are connected to the back panel of drawer #15 using Camlock, then the bottom panel of drawer #16 is inserted into the groove.
- The front panel of drawer #11 is connected to the side panels of drawers #14 using Camlock

STEP 16

HARDWARE LIST

A  8 PCS

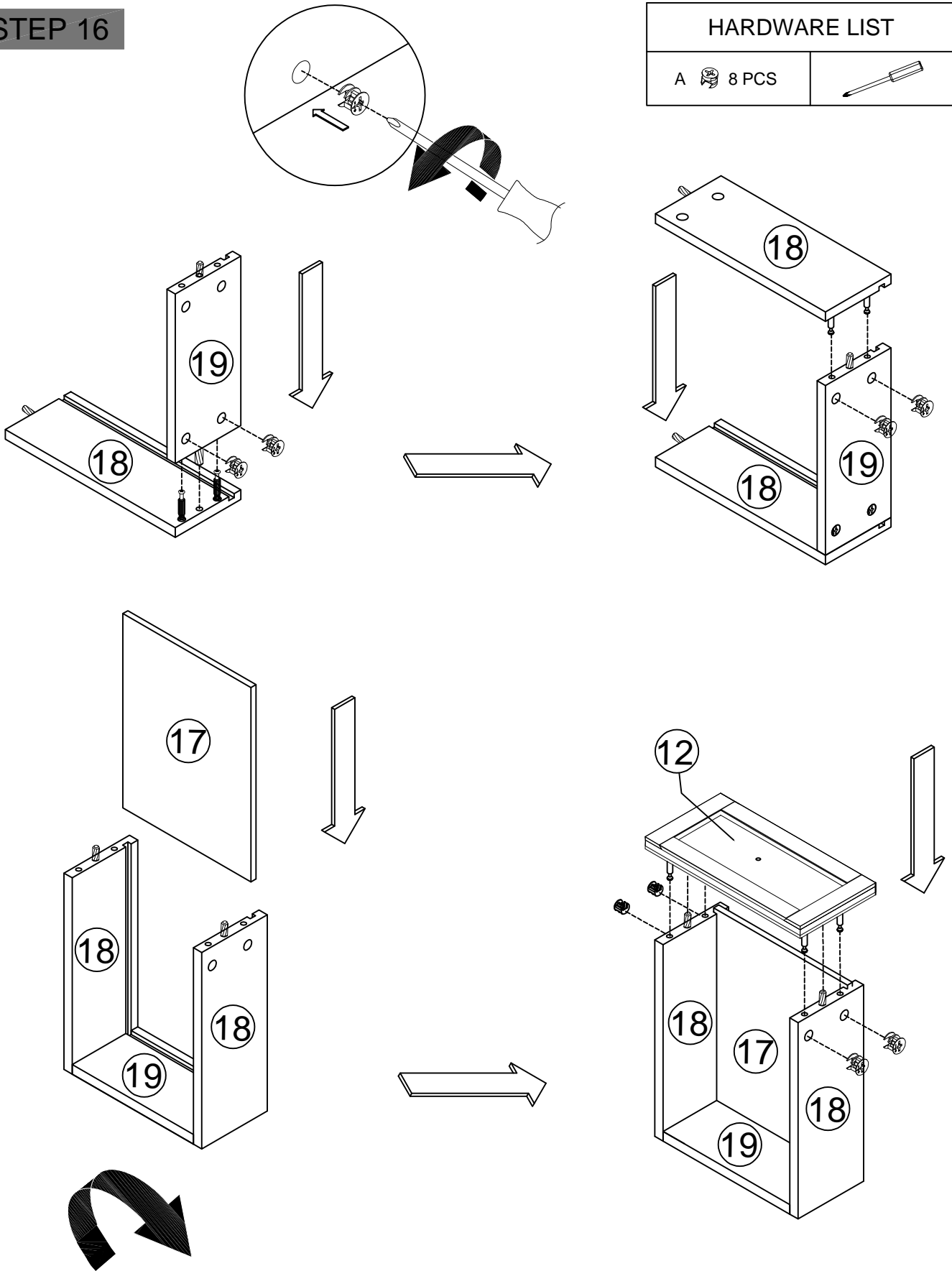
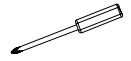

- The side panels of drawer #18 are connected to the back panel of drawer #19 using Camlock, then the bottom panel of drawer #17 is inserted into the groove.
- The front panel of drawer #12 is connected to the side panels of drawers #18 using Camlock

STEP 17

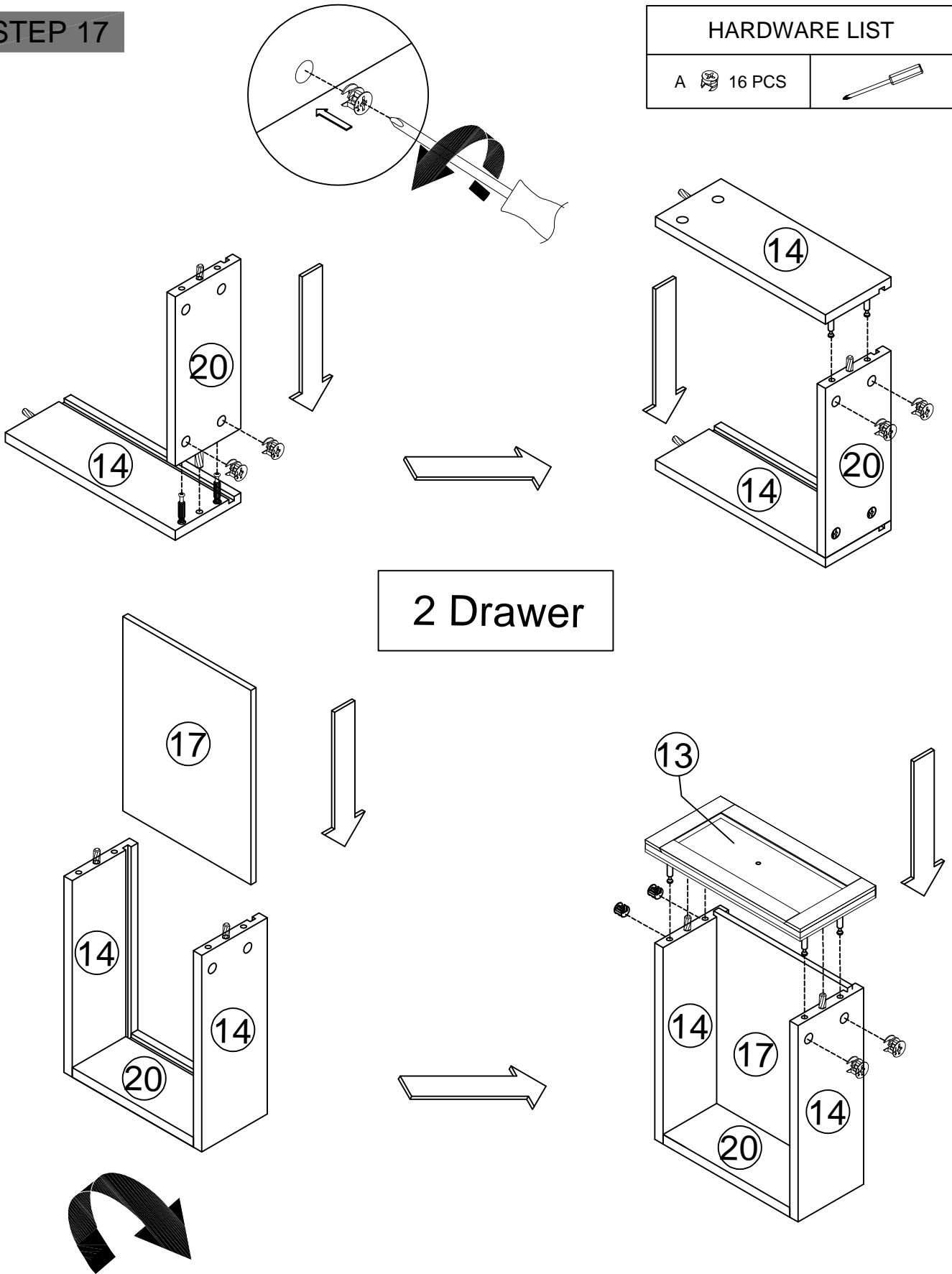
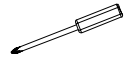

HARDWARE LIST

A  16 PCS



- The side panels of drawer #14 are connected to the back panel of drawer #20 using Camlock, then the bottom panel of drawer #17 is inserted into the groove.
- The front panel of drawer #13 is connected to the side panels of drawers #14 using Camlock

STEP 18

HARDWARE LIST	
B	 5 PCS
C	 5 PCS

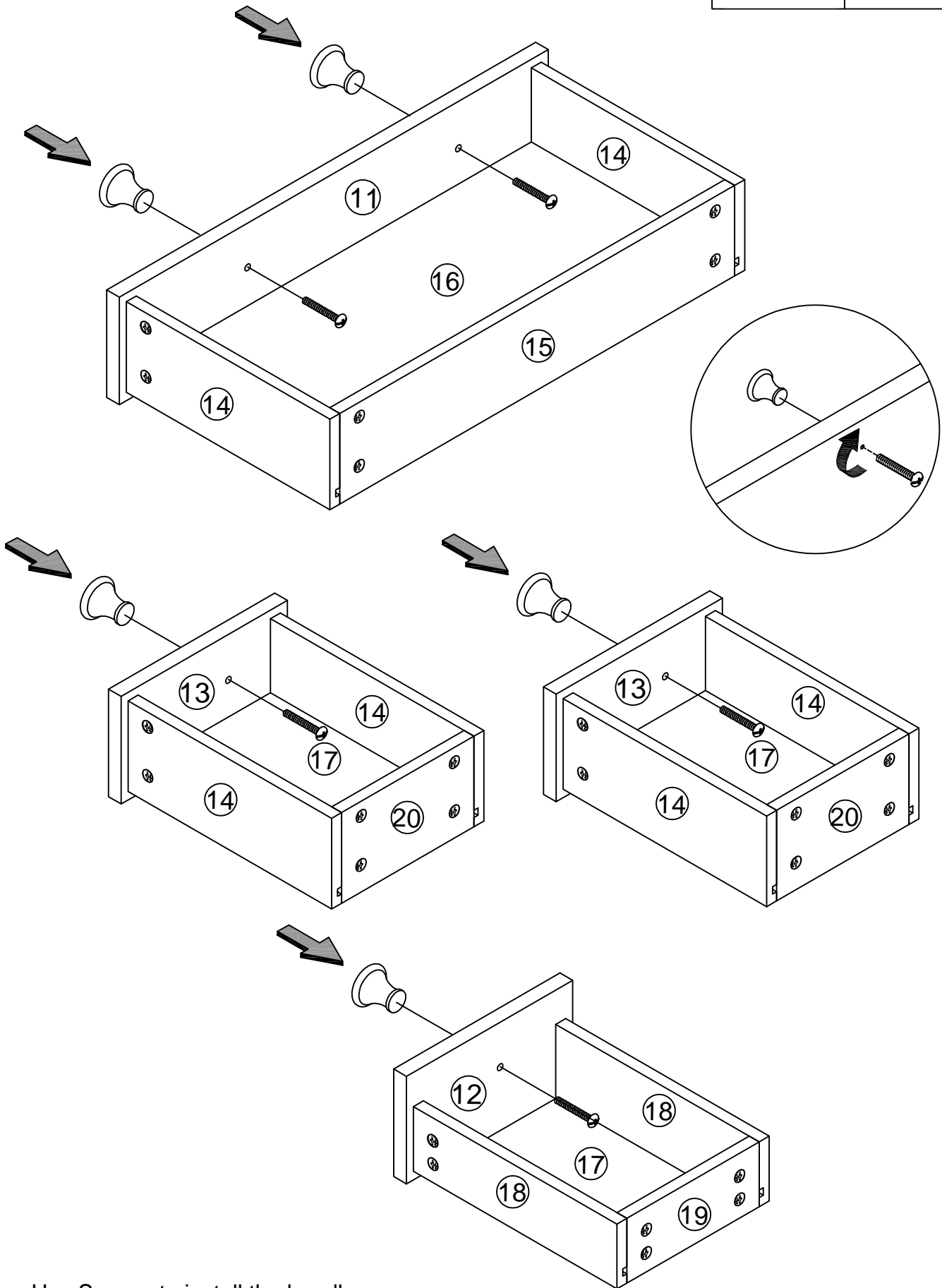
○ Use Screws to install the handle.

STEP 19

HARDWARE LIST

G  8 PCS

H  24 PCS

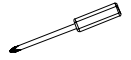

The front part
of the slide rail

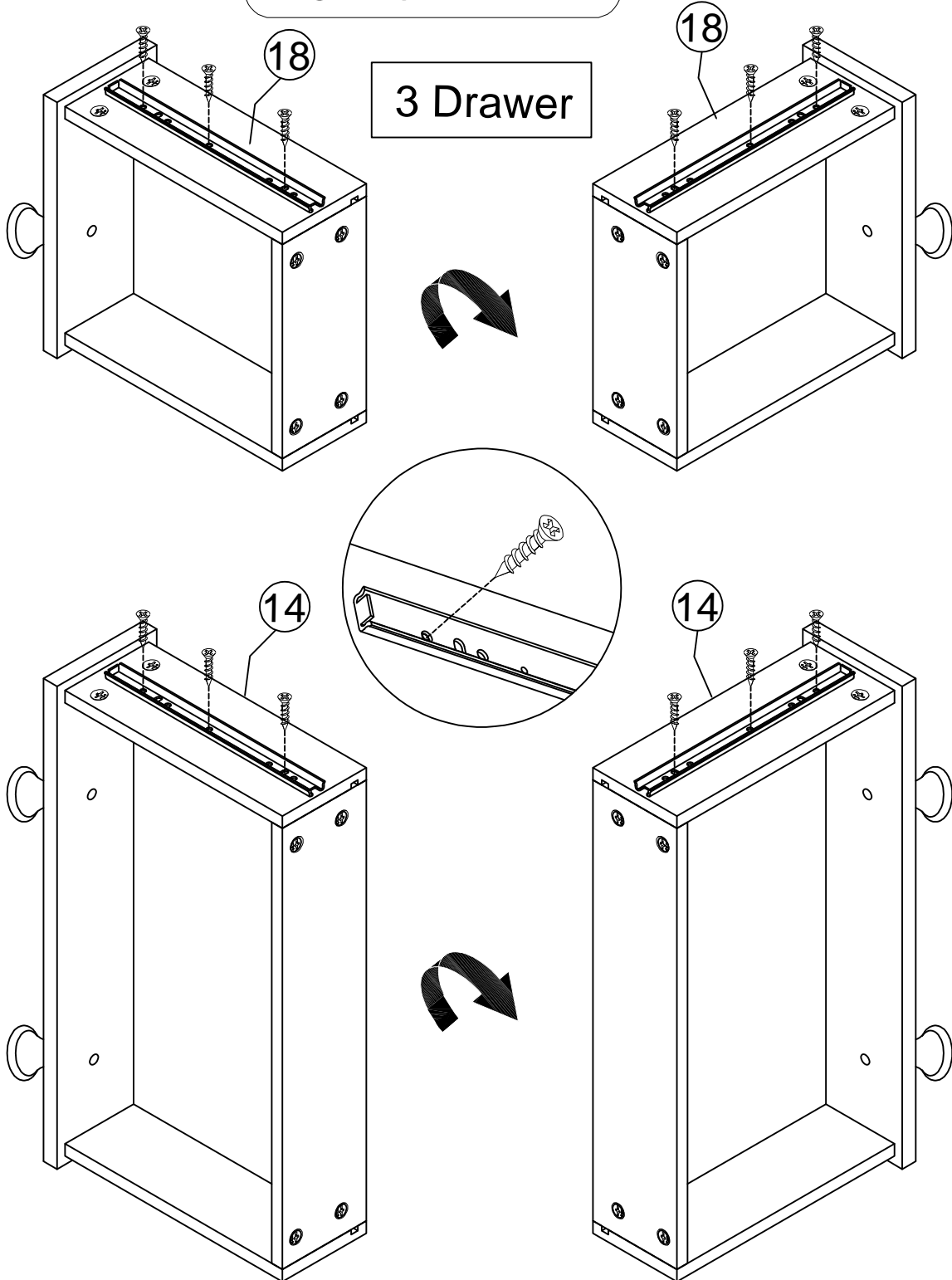
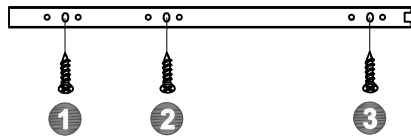

- The front part of the slide rail is attached to both side panels of the drawer using screws in the pre-drilled positioning holes

STEP 20

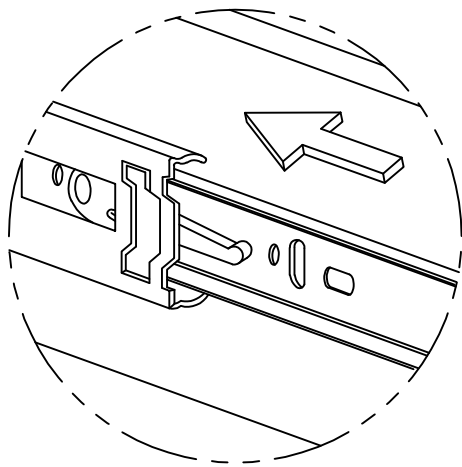
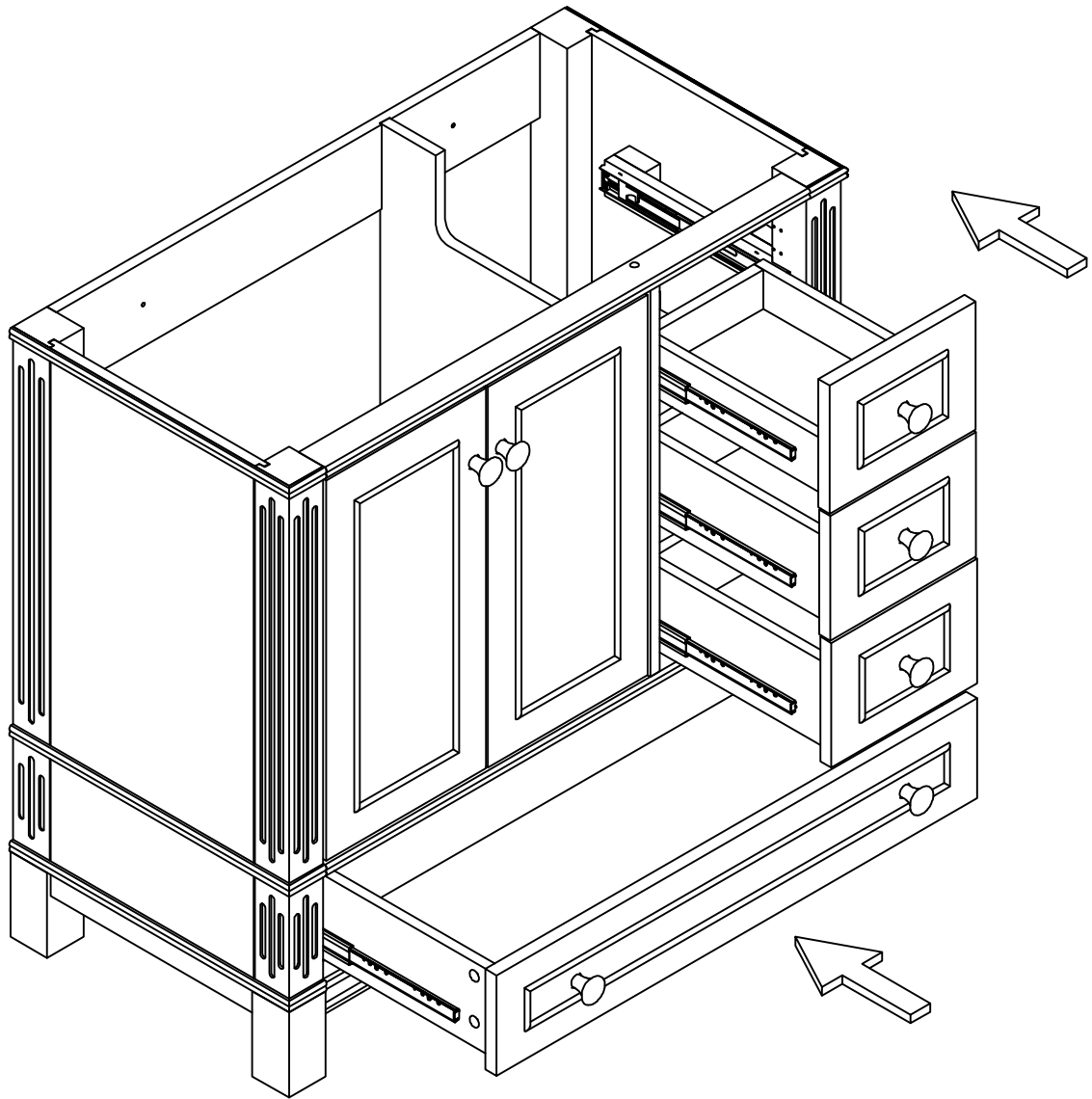

- Install the drawer so that it aligns with the slides already attached to the cabinet, then slowly push it in

STEP 21

HARDWARE LIST

J  2 PCS

J  2 PCS

J  2 PCS

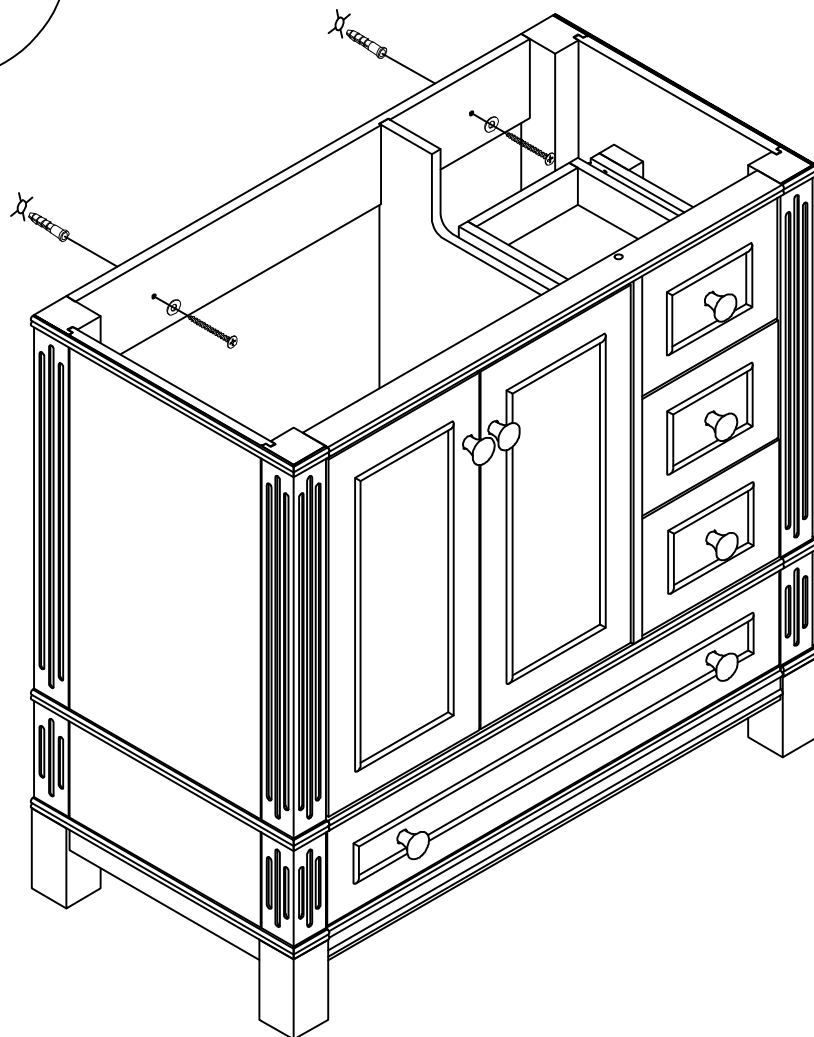
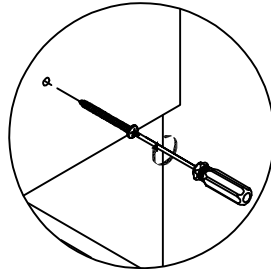
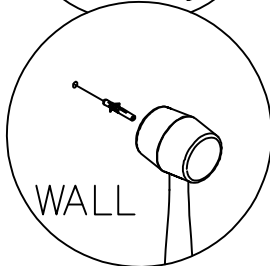
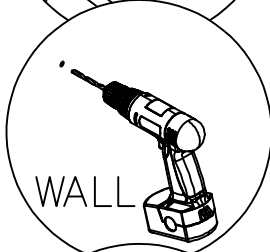
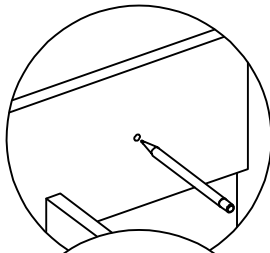
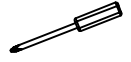

◦ Refer to the illustration, Draw the spacing between the walls on the cabinet, punch holes in the wall and fix the cabinet to the wall with screws.

STEP 22

HARDWARE LIST

M  1 PCS

Double-sided tape

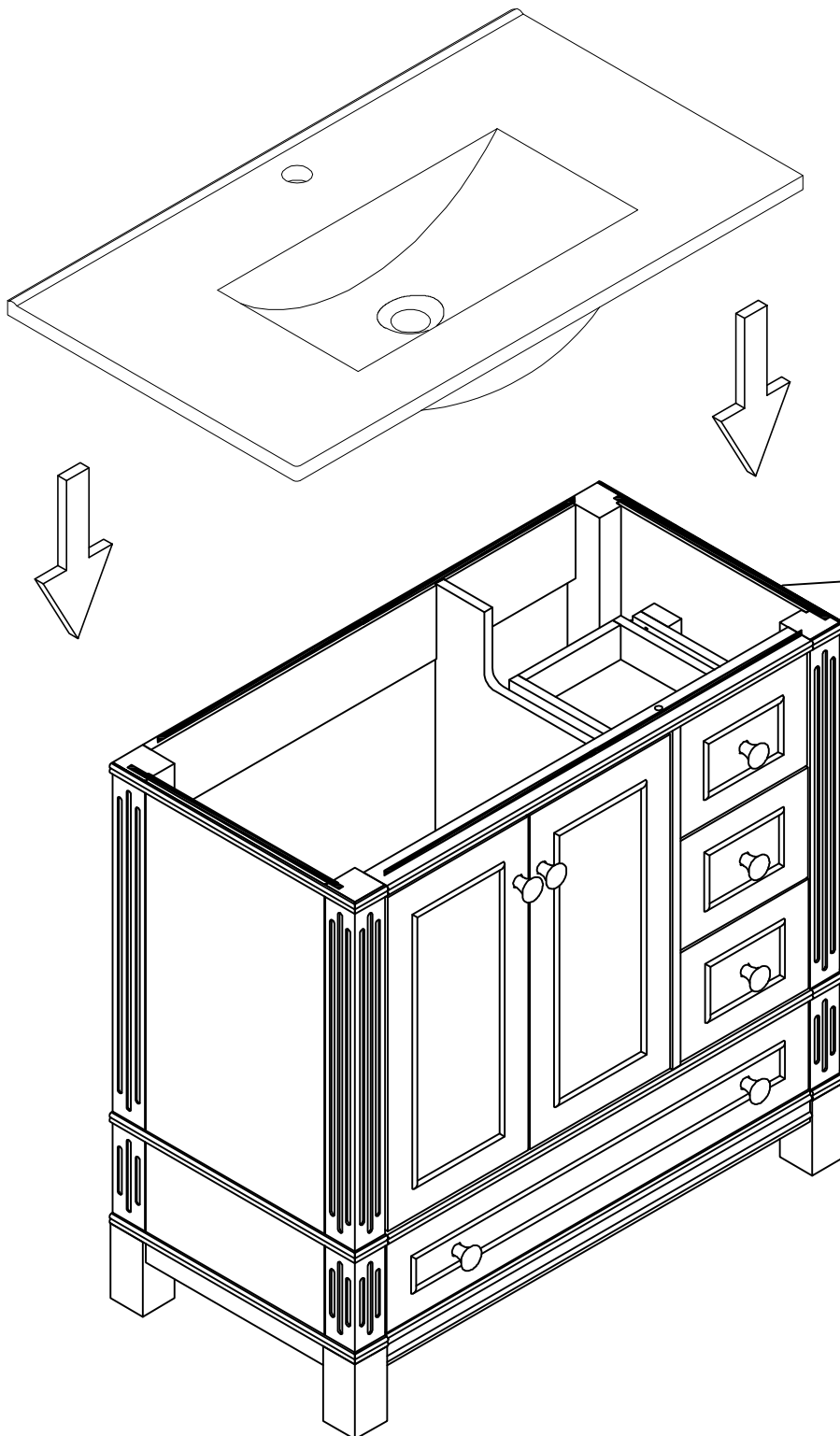

Double-sided tape

- Use double-sided adhesive tape along the top edges that contact the sink to reduce wobbling when placing the sink on the cabinet.

STEP 23

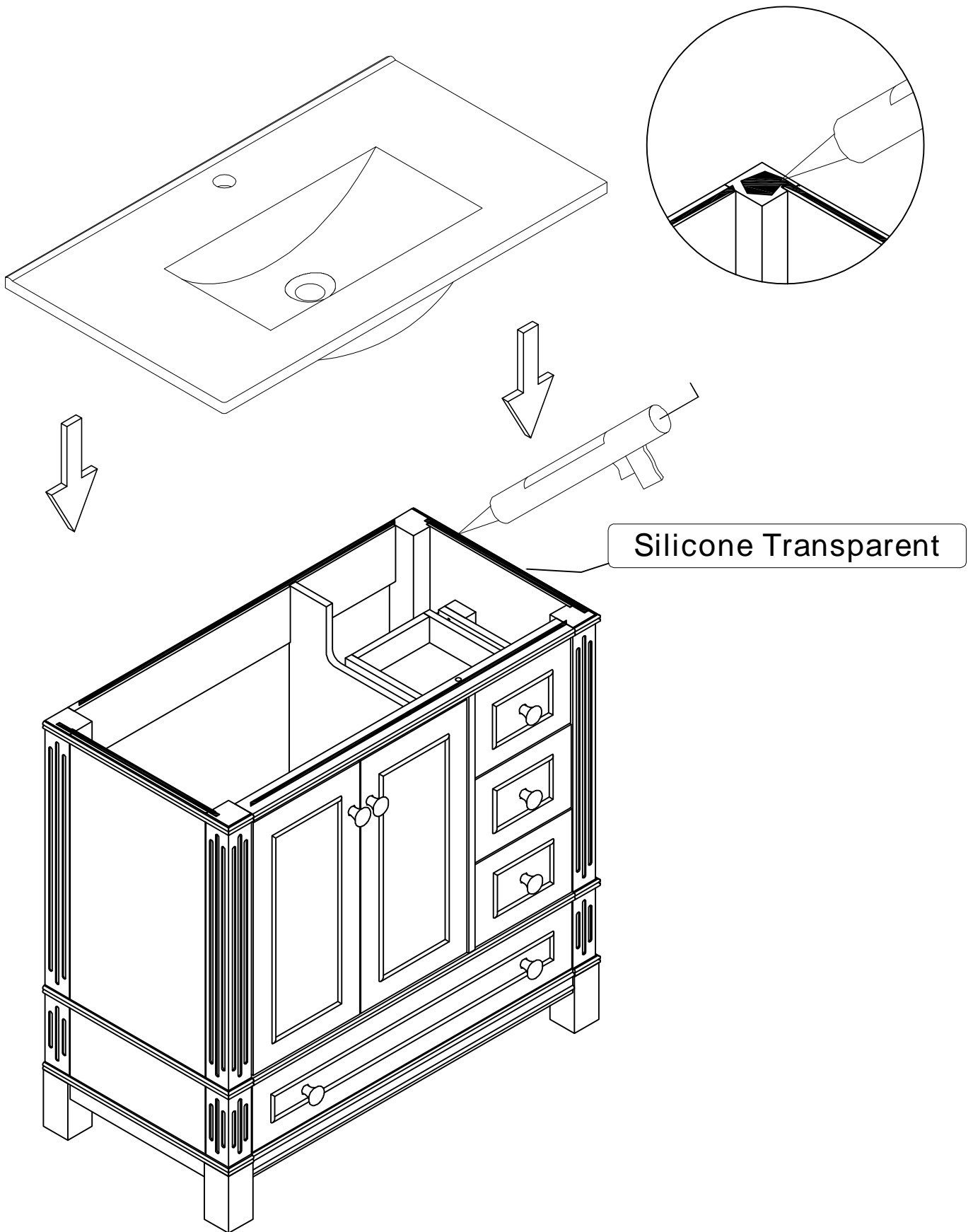

- Alternatively, silicone adhesive can be used to secure the sink in place after positioning it on the cabinet.

FINISH

