

Owner's Manual

MRT190H-rev E

Place serial number tag here



WARNING

USE EXTREME CAUTION WHILE USING THIS EQUIPMENT. INJURY CAN OCCUR. READ CAREFULLY AND UNDERSTAND ALL ASSEMBLY AND SAFE OPERATION INSTRUCTIONS BEFORE OPERATING. FAILURE TO FOLLOW THE SAFETY RULES AND OTHER BASIC SAFETY PRECAUTIONS MAY RESULT IN SERIOUS PERSONAL INJURY.





Table of Contents

- 1 INTRODUCTION5
 - 1.1 ...Application5
 - 1.2 ...Benefits.....5
 - 1.3 ...Navigating This Manual.....5
 - 1.4 ...Warnings and Safety Precautions5
 - 1.5 ...Operation References/Terminology7
 - 1.6 ...Control and Adjustment Locations.....8
 - 1.7 ...Owner Assistance.....8
 - 1.8 ...Model Identification.....9
 - 1.9 ...Further Assistance9
- 2 SAFETY 9
 - 2.1 ...General Safety Rules.....9
 - 2.2 ...PRODUCT-SPECIFIC SAFETY RULES 11
 - 2.3 ...ENGINE SAFETY PRECAUTIONS 11
 - 2.4 ...Safety Decals.....14
 - 2.5 ...Training15
 - 2.6 ...Preparation.....16
 - 2.7 ...Operation16
 - 2.8 ...Storage17
- 3 Uncrating & Handle Assembly 17
 - 3.1 ...Assemble Handle.....18
 - 3.2 ...Attach Drive Rods.....18
 - 3.3 ...Install Spring19
 - 3.4 ...Plug In Wire Harness.....19
- 4 PARTS BREAKDOWN 20
 - 4.1 ...Chaincase Breakdown.....20
 - 4.2 ...Tines Breakdown.....21
 - 4.3 ...Main Unit Breakdown22
 - 4.4 ...General Information.....25
- 5 ASSEMBLY**Error! Bookmark not defined.**
 - 5.1 ...Final Set-up**Error! Bookmark not defined.**



6 OPERATING CONTROLS 27
6.1 ... *To Start Engine*..... 27

7 MACHINE IDENTIFICATION COMPONENTS..... 28

8 OPERATION 28
8.1 ... *Drive operation*..... 28
8.2 ... *Tine operation*..... 28
8.3 ... *Safe operation while tilling*..... 29
8.4 ... *Depth Bar Stake* 29
8.5 ... *Turning sharply*..... 30
8.6 ... *Tilling* 30
8.7 ... *Cultivating* 31

9 Transporting – pushing tiller without engine running/power 32
9.1 ... *Hydraulic Pump Lock Out/Release* 32

10 MAINTENANCE AND LUBRICATION 32
10.1 . *Cleaning* 32
10.2 . *Cleaning the Cooling System* 33
10.3 . *Dual Filter Element Air Cleaner*..... 33
10.4 . *Engine Oil – 1.16 quart, (38.63 oz)*..... 33
10.5 . *Hydraulic Oil - Capacity is approx. one gallon*..... 34
10.6 . *Tine Chain Case* 35
10.7 . *Muffler* 36
10.8 . *Spark Plug*..... 36

11 Tire Care..... 36
11.1 . *Maintenance Schedule* 37

12 WARRANTY 37
12.1 . *Warranty/Product Registration* 37

 WARNING**READ ENTIRE MANUAL BEFORE ATTEMPTING TO OPERATE MACHINE**

If incorrectly used, this machine can cause severe injury. Those who use and maintain this machine should be trained in its proper use, warned of its dangers, and should read the entire manual before attempting to set up, operate, adjust, or service this machine.

Read and keep this manual for future reference. This manual contains important information on **SAFETY, ASSEMBLY, OPERATION, AND MAINTENANCE**. The owner must be certain that all the product information is included with the unit. This information includes the **MANUAL, the REPLACEMENT PARTS, and the WARRANTIES**. This information must be included to make sure state laws and other laws are followed. This manual should remain with the product even if it is resold.

 WARNING**THE ENGINE EXHAUST FROM THIS PRODUCT CONTAINS CHEMICALS KNOWN TO THE STATE OF CALIFORNIA TO CAUSE CANCER, BIRTH DEFECTS OR OTHER REPRODUCTIVE HARMS.**

IMPORTANT: This unit is equipped with an internal combustion engine and should not be used on or near any unimproved forest-covered, brush covered, or grass-covered land unless the engine's exhaust system is equipped with a spark arrester meeting applicable local laws (if any). If a spark arrester is used, it should be maintained in effective working order by the operator.

In the state of California, a spark arrester is required by law (section 4442 of the California public resources code). Other states may have similar laws. Federal laws apply on federal lands. See your authorized service center for a spark arrester.

1 INTRODUCTION

Maxim rear-tine tillers feature heavy gauge steel, hardened steel tines and ruggedly built Hydrostatic transmission. For additional durability, an extra heavy-duty frame. It is this simple, yet sturdy design that makes Maxim tillers low maintenance and easy to use.

Please read this entire manual before assembly and use. The manufacturer reserves the right to change, alter or improve the product and this document at any time without prior notice.

1.1 Application

Tillers in the rental industry must be able to withstand heavy use, rough handling, and transportation bruises, yet still rent tomorrow. These beefy tillers combine ease of operation and maintenance to make a tiller worthy of the Maxim name.

1.2 Benefits

- Rear tine tiller operation provides an easier to handle, better tilling operation, especially in fresh un-tilled ground.
- Hydraulic Transmission provide ease of use, with having infinite variable speed between high and low operation, also provides increased durability.
- Heavy-duty tines with bolt-on replaceable blades.
- Both Forward and Reverse tine operation for that perfect tilling job.
- Heavy-duty steel wheels with “Bar” type tires.
- Heavy-duty frame for long life.
- Depth bar standard for tilling depth control.

1.3 Navigating This Manual

1. Use this manual to help familiarize yourself with safety, operation, adjustments, troubleshooting, maintenance, specifications, and warranty information. It is very important that you read this manual and follow the instructions to ensure safe operation of the attachment.
2. Please visit www.maximmfg.com for updated information.

1.4 Warnings and Safety Precautions

The safety of our customers and other’s well-being is very important to us. Using this equipment is an important responsibility. Safe and effective use of the machine is the owner’s responsibility.

- Read and follow all safety instructions.
- Maintain the machine according to directions and schedule included in this manual.
- Ensure that anyone who uses the machine is familiar with all controls and safety precautions.

SPECIAL MESSAGES

Please read all the information carefully to avoid injury and machine damage. This information alerts you to potential hazards that could hurt you or others.



NOTE: General information is given throughout the manual that may help the operator in the operation or service of the machine.

You will find important safety information in a variety of forms, including:

1. Safety labels – on the tillers
2. Safety messages – preceded by a safety alert symbol  and one of the three signal words: **DANGER, WARNING, OR CAUTION.**

These signal words mean:

DANGER: You will be killed or seriously injured if you do not follow instructions

 DANGER

WARNING: You can be killed or seriously injured if you do not follow instructions.

 WARNING
WARNING INDICATED A HAZARD WHICH, IF NOT AVOIDED, COULD RESULT IN DEATH OR SERIOUS INJURY AND/OR PROPERTY DAMAGE

CAUTION: You can be injured if you do not follow instructions.

 CAUTION
CAUTION INDICATED YOU CAN BE HURT OR YOUR EQUIPMENT DAMAGED IF THE SAFETY INSTUCTIONS THAT FOLLOW THIS SIGNAL WORD ARE NOT OBEYED.

⚠ WARNING

CALIFONINA PROPOSITION 65 WARNING

ENGINE EXHAUST FROM THIS PRODUCT CONTAINS CHEMICALS KNOWN TO THE STATE OF CALIFORNIA TO CAUSE CANCER, BIRTH DEFECTS, OR OTHER REPRODUCTIVE HARM.

⚠ WARNING

YOU MUST READ, UNDERSTAND AND COMPLY WITH ALL SAFETY AND OPERATING INSTRUCTIONS IN THIS MANUAL BEFORE ATTEMPTING TO SETUP AND OPERATE YOUR MACHINE.

FAILURE TO COMPLY WITH ALL SAFETY AND OPERATING INSTRUCTIONS CAN RESULT IN LOSS OF MACHINE CONTROL, SERIOUS PERSONAL INJURY TO YOU AND/OR BYSTANDERS, AND RISK OF EQUIPMENT AND PROPERTY DAMAGE. THE TRIANGLE IN THE TEXT SIGNIFIES IMPORATNT CAUTIONS OR WARNINGS WHICH MUST BE FOLLOWED

⚠ This symbol points out important safety instructions which if not followed could endanger your personal safety. Read and follow all instructions in this manual before attempting to operate this equipment.

BEFORE OPERATING ENGINE:

Please read this section carefully. Read entire operating and maintenance instructions for this product. Failure to follow instructions could result in serious injury or death. Operate the machine according to the safety instructions outlined here and inserted throughout the text. Anyone who uses this machine must read the instructions and be familiar with the controls.

Intended Use / Foreseeable Misuse

IMPORTANT: This is a motorized rotary tiller that works the soil by means of rotating tines. It is pedestrian-controlled using hand controls that operating both tine rotation forward/directions and controls that power the entire machine both forward and reverse. It uses a gasoline-fueled internal combustion engine to power the tines. It shall not be used for any other purpose.

1.5 Operation References/Terminology

References throughout this manual referred to as “Right” or “Left” are determined by being face-standing behind tiller and facing the direction the unit will operate while in use.



1.6 Control and Adjustment Locations

Familiarize yourself with the location of various controls and adjustments located on the unit.

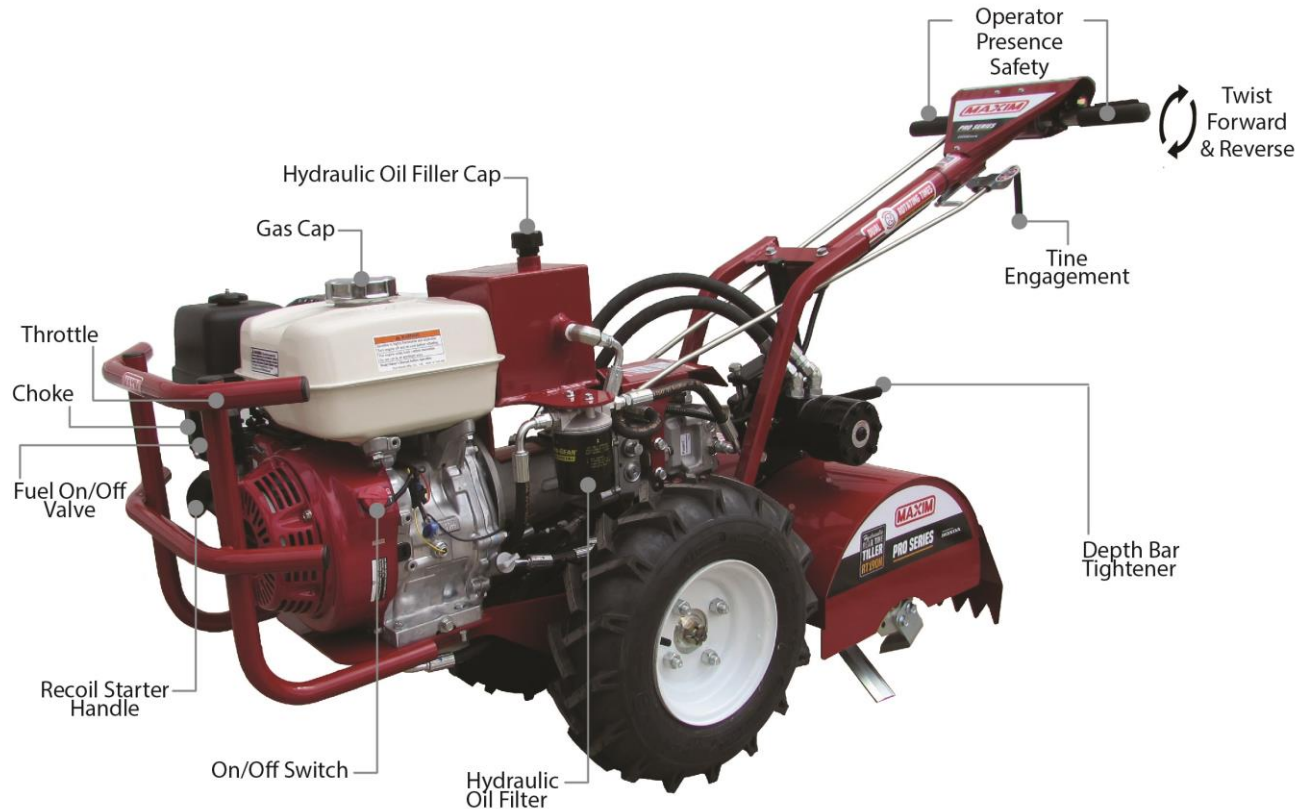

1.7 Owner Assistance

Please complete the Warranty/Product Registration at the time of purchase. You will need to complete the warranty/product registration form (pg. 38) with your new unit, or you may visit our website www.maximmfg.com and complete our online product registration form. We require this information so we can keep you updated with any important information about your tiller and provide you with the best customer service possible.

The parts and components used on your Maxim tiller have been specifically engineered for Maxim tiller and should only be replaced with Maxim parts. Contact your local Maxim Dealer for OEM replacement parts or contact our customer service department for assistance in parts, locating your local servicing dealer and more. Your local dealer is equipped and trained to handle service and repair for your tiller.

1.8 Model Identification

Please fill in your model and serial number below for future reference. This will help assist in prompt service when ordering parts and service from your local Maxim Dealer.

Tiller Model No. _____ Tiller Serial No. _____

Engine Model No. _____ Engine Serial No. _____

Refer to the image below for location of your serial number plate:



Tiller Serial Number  under handlebar



Engine Serial Number 

1.9 Further Assistance

Your dealer and all of us at Maxim want you to be pleased with your tiller. Should you require further assistance or have questions regarding your tiller, please contact your local dealer where you purchased your tiller. If you are unable to satisfy your needs by your local dealer, please contact us at:

Maxim
20195 South Diamond Lake Road, STE 100
Rogers, MN 55374
800-621-2789
www.maximmfg.com

2 SAFETY

2.1 General Safety Rules

- Read, understand, and follow all instructions on the machine and in the manual(s). Be thoroughly familiar with the controls and proper use of the machine before starting.
- Disengage all controls before starting the engine (motor).
- Use this equipment for its intended purpose only.
- Familiarize yourself with all the safety and operating decals on this equipment and on any of its attachments or accessories.
- Stop the engine (motor) when leaving the operating position.
- Do not put hands or feet near or under rotating parts.



- Only allow responsible individuals who are familiar with the instructions to operate the machine. Do not allow children to operate this machine. Do not allow adults to operate the machine without proper instruction.
- Thoroughly inspect the area where the machine is to be used and remove all foreign objects. Your equipment can propel small objects at high-speed causing personal injury or property damage. Stay away from breakable objects, such as house windows, automobiles, greenhouse, etc.
- Wear appropriate clothing such as sturdy, rough-soled shoes (steel toe recommended) and close-fitting pants and shirt. Loose fitting clothes or jewelry can be caught in moving parts. Never wear shorts. Never wear sandals, sneakers, or open shoes, and never operate the machine with bare feet.
- Do not wear loose clothing or jewelry. They can get caught in moving parts. Always keep hands, feet, hair, and loose clothing away from any moving parts on engine and machine.
- Always wear safety goggles or safety glasses with side shields when operating the machine to protect your eyes from foreign objects which can be thrown from the unit.
- Always wear a protective hearing device.
- Always wear work gloves and sturdy rugged soled footwear. Wear footwear that will improve footing on slippery surfaces. Leather work shoes or short boots work well for most people. These will protect the operator's ankles and shins from small sticks, splinters, and other debris.
- It is advisable to wear protective headgear to prevent the possibility of being struck by small flying particles, or being struck by low hanging branches, twigs or other objects which may be unnoticed by the operator.
- Do not operate the machine without proper guards or other safety protective devices in place.
- Operate only in daylight.
- Do not operate product when fatigued or under the influence of alcohol, drugs or other medication which can cause drowsiness or affect your ability to operate machine safely.
- Never operate machine in wet grass. Always be sure of your footing; keep a firm hold on the handle and walk; never run.
- Watch for traffic when operating tiller near, or when crossing roads.
- If the equipment should start to vibrate abnormally, stop the engine (motor), rotate the ON/OFF switch located on the engine to the **OFF** position.
- Regularly inspect the machine. Make sure parts are not bent, damaged or loose.
- Temperature of muffler and nearby areas may exceed 150° F (65° C). Allow muffler and engine areas to cool before touching.
- Prolonged exposure to noise and vibration from gasoline engine-powered equipment should be avoided. Take intermittent breaks and/or wear ear protection from engine noise as well as heavy work gloves to reduce vibration in hands.
- Keep all screws, nuts, and bolts tight.

- Do not transport the machine from one place to another with the engine running.
- Always turn off fuel supply valve on engine before transport.
- Check local regulations for age restrictions on use of this machine.

2.2 PRODUCT-SPECIFIC SAFETY RULES

- Do not till above underground utilities, including water lines, gas lines, electric cables, or pipe. Contact appropriate utility representatives to determine if/where electrical cables, gas lines, water lines, etc. are buried BEFORE operation.
- Do not operate the machine on terrain/soil with large rocks and foreign objects which can damage the equipment.
- After striking a foreign object, stop the engine. Rotate the ON/OFF switch located on the engine to the **OFF** position. Inspect the machine for damage. If damaged, repair before starting and operating the machine.
- The tines of the tiller should not rotate when the engine is idling. If they do, contact your local dealer or Maxim technical service for instruction.
- If an object becomes lodged in the tines, rotate the ON/OFF switch located on the engine to the **OFF** position. Allow the machine to cool before attempting to remove the foreign object.
- Keep the area of operation clear of all persons, particularly small children, and pets.

2.3 ENGINE SAFETY PRECAUTIONS

WARNING

ENGINES GIVE OFF CARBON MONOXIDE, AN ODORLESS, COLORLESS, POISONOUS GAS. CARBON MONOXIDE MAY BE PRESENT EVEN IF YOU DO NOT SMELL OR SEE ANY ENGINE EXHAUST. BREATHING CARBON MONOXIDE CAN CAUSE NAUSEA, FAINTING OR DEATH, IN ADDITION TO DROWSINESS, DIZZINESS AND CONFUSION.

IF YOU EXPERIENCE ANY OF THESE SYMPTOMS, SEEK FRESH AIR AND MEDICAL ATTENTION IMMEDIATELY.

CAUTION

HOT GASES ARE A NORMAL BY-PRODUCT OF A FUNCTIONING INTERNAL COMBUSTION ENGINE. FOLLOW ALL SAFETY INSTRUCTIONS TO PREVENT BURNS AND FIRES.

DO NOT ALTER/MODIFY ENGINE:

NEVER ALTER OR MODIFY THE ENGINE FROM THE FACTORY. SERIOUS INJURY OR DEATH MAY OCCUR IF ENGINE IS MODIFIED OR ALTERED.

WHEN WORKING ON OR REPLACING PARTS FOR THE ENGINE OR PRODUCT, YOU MUST ALWAYS FLIP THE ON/OFF SWITCH TO THE OFF POSITION.

PREVENTING CARBON MONOXIDE POSIONING

- Always start and run engine outdoors. Do not start or run engine in an enclosed area, even if doors or windows are open.
- Never try to ventilate engine exhaust indoors. Carbon monoxide can reach dangerous levels very quickly.
- Never run engine outdoors where exhaust fumes may be pulled into a building.
- Never run engine outdoors in a poorly ventilated area where the exhaust fumes may be trapped and not easily taken away. (Examples include in a large hole or areas where hills surround your working area.)
- Never run engine in an enclosed or partially enclosed area. (Examples include buildings that are enclosed on one or more sides, under tents, car ports or basements.)
- Always run the engine with the exhaust pointed in the direction away from the operator.
- Never point the exhaust towards anyone. People should always be a minimum of ten feet away from the operation of the engine and its attachments.
- Do not change the engine governor settings or over-speed the engine.
- Stop the engine (motor) when leaving the operating position.

GASOLINE FIRES AND HANDLING FUEL SAFELY

 **Warning gasoline is highly flammable and explosive**

You can be burned or seriously injured when handling fuel. Use extreme care when handling gasoline or other fuels. They are flammable and vapors are explosive.

- When storing extra fuel be sure that it is in an appropriate container and away from any fire hazards.
- Prevent fire and explosion caused by static electric discharge. Use only nonmetal, portable fuel containers approved by the Underwriter's Laboratory (U.L.) or the American Society for Testing & Materials (ASTM).
- Always fill fuel tank outside in a well-ventilated area. Never fill fuel tank with fuel indoors. (Examples include basement, garage, barn, shed, house, porch, etc.) Never fill tank near appliances with pilot lights, heaters, or other ignition sources. If the fuel must be drained, this should be done outdoors. The drained fuel should be stored in a container specifically designed for fuel storage or it should be disposed of carefully.
- Never remove the fuel cap or add fuel with the engine running. Stop engine and allow to cool before filling.
- Do not smoke while using engine or around fuel.
- Never drain fuel from engine in an enclosed area.





- Always wipe up excess (spilled) fuel from engine before starting. Clean up spilled fuel immediately. If fuel is spilled, do not start the engine but move product and fuel container from area. Clean up spilled fuel and allow to evaporate and dry after wiping and before starting.
- Allow fuel fumes/vapors to escape from the air before starting the engine.
- Test the fuel cap for proper installation before starting and using engine.
- Always run the engine with fuel cap properly installed on the engine.
- Never smoke while refilling engine fuel tank.
- Do not store engine with fuel in fuel tank indoors. Fuel and fuel vapors are highly explosive.
- Never pour fuel from engine fuel tank.
- Never siphon fuel by mouth to drain fuel tank.
- Always have an adult fill the fuel tank and never allow children to fill the engine.
- Never allow anyone under the influence of drugs or alcohol to fill the engine.
- When storing gasoline or equipment with fuel in the tank, store away from furnaces, stoves, water heaters or other appliances that have a pilot light or other ignition source because they can ignite gasoline vapors.

BURNS AND FIRES

The muffler, muffler guard and other parts of the engine become extremely hot during the operation of the engine. These parts remain extremely hot after the engine has stopped.

- Never remove the muffler guard from the engine.
- Never touch the muffler guard because it is extremely hot and will cause severe burns.
- Never touch parts of the engine that become hot after operation.
- Always keep materials and debris away from the muffler guard and other hot parts of the engine to avoid fires.

CHILDREN AND BYSTANDERS

Tragic accidents can occur if the operator is not alert to the presence of children and/or bystanders. Never assume that others will remain where you last saw them.

- Keep the area of operation clear of all persons, especially small children, and pets. Keep children under the watchful care of a responsible adult.
- Be alert and turn machine off if children enter the area.
- Before and while moving backwards, look behind and down for small children.
- Never allow children to operate the machine.
- Use extra care when approaching blind corners, shrubs, trees, or other objects that may obscure vision.

SERVICE

- Always stop the engine whenever you leave the equipment, before cleaning, repairing, or inspecting the unit. Engine should be turned off and cool. Never make adjustments or repairs with the engine (motor) running. Disconnect the spark plug wire and keep the wire away from the plug. Rotate the ON/OFF switch located on the engine to the **OFF** position to prevent accidental starting.
- Always wear eye protection when you make adjustments or repairs.
- Keep all nuts and bolts tight and keep equipment in good condition.
- Never tamper with safety devices. Check their proper operation regularly.
- When servicing or repairing the machine, do not tip the machine over or up unless specifically instructed to do so in this manual. Service and repair procedures can be done with the machine in an upright position. Some procedures will be easier if the machine is on a raised platform or working surface.
- To reduce fire hazard, keep machine free of grass, leaves or other debris build-up. Clean up oil or fuel spillage. Allow machine to cool before storing.
- Stop and inspect the equipment if you strike an object. Repair, if necessary, before restarting.
- Clean and replace safety and instruction decals, as necessary.
- To guard against engine over-heating, always have engine air filter mounted and clean.
- Inspect machine before storage. When not in use, rotate the ON/OFF switch located on the engine to the **OFF** position and store indoors in a dry place locked or otherwise inaccessible to children.
- Use only original equipment parts from the factory, including all nuts and bolts.

2.4 Safety Decals

This Tiller has been designed and manufactured to provide you the safety and reliability you would expect from an industry leader in outdoor power equipment manufacturing.

Reading this manual and the safety instructions it contains will provide you with the necessary basic knowledge to operate this equipment safely and effectively. We have placed safety decals on the tiller to remind you of some of this important information while you are operating the unit.

These important safety decals are illustrated below and are shown here to help familiarize you with the content of the safety messages you will see as you perform normal tilling operations. Please review these decals now, and if you have any questions regarding its meaning or how to comply with these instructions, reread the complete safety instruction text in this manual, or contact your local dealer.

Should a decal become unreadable because of being worn, faded or otherwise damaged during the use of your tiller; please use the part number information provide to order a replacement label. These decals are easily applied and will act as a constant visual reminder to you, and others who may use the equipment, to follow the safety instructions necessary for safe, effective operation of your tiller.

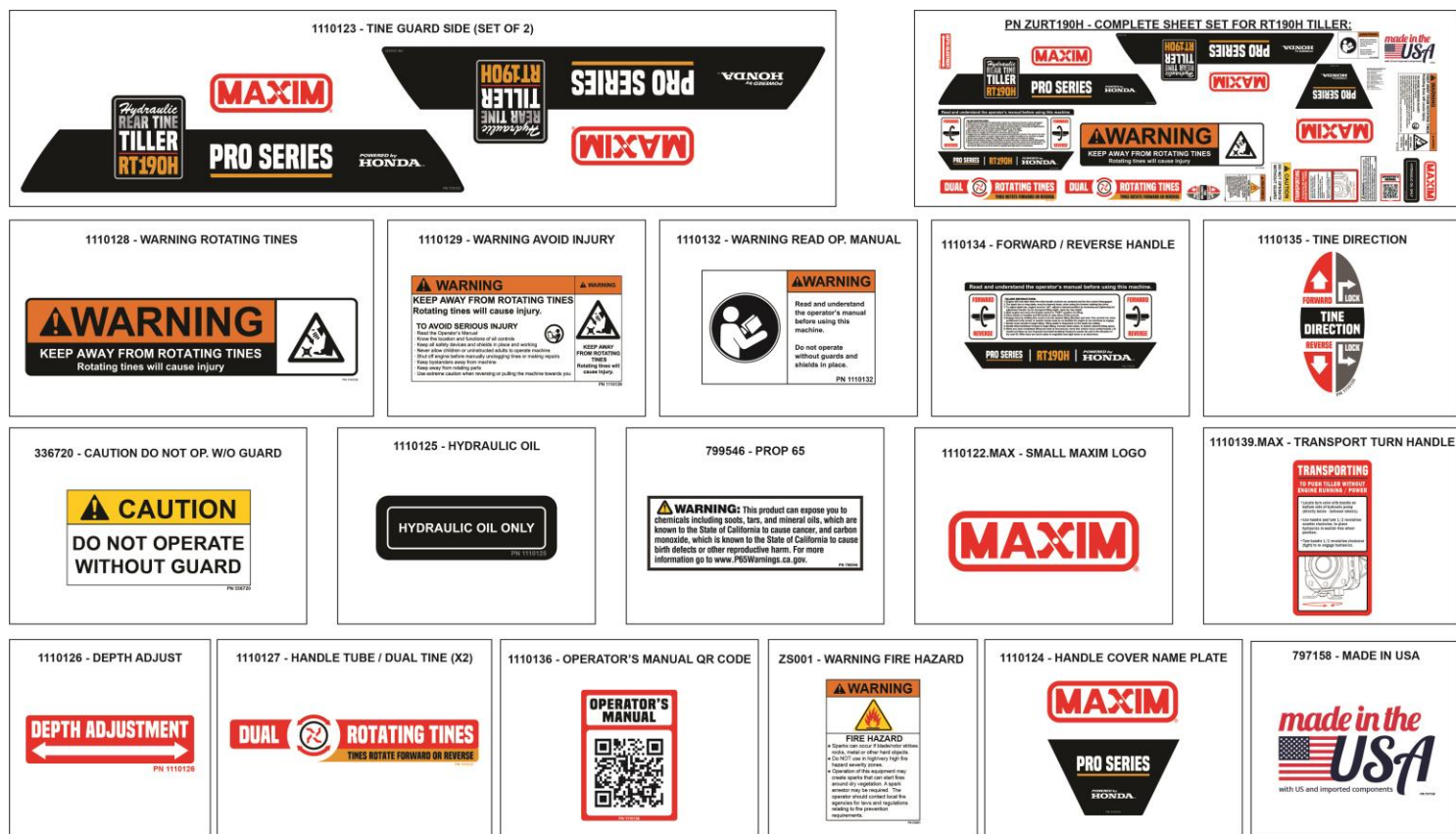

2.5 Training

1. Read the Owner’s Manual carefully. Be thoroughly familiar with the controls and the proper use of the equipment. Know how to stop the unit and disengage the tines quickly.
2. Never allow children to operate the equipment. Never allow adults to operate the equipment without proper instructions.
3. Keep the area of operation clear of all persons, particularly small children, and pets.
4. Always stay alert. Watch what you are doing and use common sense. Do not operate unit when fatigued.
5. Understand the use of all tiller controls.

2.6 Preparation

1. Thoroughly inspect the area where the equipment is to be used and remove all foreign objects.
2. Disengage the tines before starting the engine (motor).
3. Always wear substantial footwear and long pants. Do not operate the equipment when barefoot or wearing open sandals.
4. Wear ear and eye protection. Eye protection must meet applicable CE requirements. To avoid hearing damage, we recommend hearing protection be worn whenever using the equipment.
5. Handle fuel with care; it is highly flammable.
6. Use an approved fuel container.
7. Never add fuel to a running engine or hot engine.
8. Fill fuel tank outdoors with extreme care. Never fill fuel tank indoors.
9. Replace gasoline cap securely and clean up spilled fuel before starting.
10. Never attempt to make any adjustments while the engine (motor) is running.

2.7 Operation

1. Do not put hands or feet near or under rotating parts.
2. Exercise extreme caution when operating on or crossing gravel drives, walks, or roads. Stay alert for hidden hazards or traffic. Do not carry passengers.
3. After striking a foreign object, stop the engine (motor) by rotating the ON/OFF switch located on the engine to the **OFF** position, thoroughly inspect the tiller for any damage, and repair the damage before restarting and operating the tiller.
4. Exercise caution to avoid slipping or falling.
5. If the unit should start to vibrate abnormally or make unusual noise, stop the engine (motor), and check immediately for the cause. Vibration is generally a warning of trouble.
6. Stop the engine (motor) when leaving the operating position.
7. Take all possible precautions when leaving the machine unattended. Disengage the tines and stop the engine by turning the ON/OFF switch located on the engine to the **OFF** position.
8. Before cleaning, repairing, or inspecting, shut off the engine and make certain all moving parts have stopped. Disconnect the spark plug wire and keep the wire away from the plug to prevent accidental starting.
9. Do not run the engine indoors; exhaust fumes are dangerous.
10. Never operate the tiller without proper guards, plates, or other safety protective devices in place.
11. Keep children and pets away when operating.
12. Do not overload the machine capacity by attempting to till too deep or too fast.
13. Never operate the machine at high speeds on slippery surfaces. Look behind and use care when backing up.
14. Never allow bystanders near the unit.

15. Use only attachments and accessories approved by the manufacturer of the tiller.
16. Never operate the tiller without good visibility or light.
17. Be careful when tilling in hard ground. The tines may catch in the ground and propel the tiller forward. If this occurs, let go of the handlebars and do not restrain the machine.

2.8 Storage

1. Keep machine, attachments, and accessories in safe working conditions.
2. Check assembly pins, engine mounting bolts, and other bolts for proper tightness to be sure the equipment is in safe working condition.
3. Check for Hydraulic leaks from hoses or at hose connections.
4. Never store the machine with fuel in the fuel tank inside a building where ignition sources are present, such as hot water and space heaters, clothes dryers, etc. allow the engine to cool before storing in any enclosure.
5. Fuel stabilizer is an acceptable alternative in minimizing and formation of fuel gum deposits during storage. Run engine at least 10 minutes after adding stabilizer to allow the stabilizer to reach the carburetor. It is not necessary to drain either carburetor or fuel tank when using fuel stabilizer.
6. Touch up all rusted or chipped paint surfaces; sand lightly before painting.
7. If possible, store your unit indoors and once sufficiently cooled, cover it to give protection from the elements.

3 Uncrating & Handle Assembly

Remove Top boards and un-bolt Upper Handle assembly. Save fasteners and discard shipping bracket.

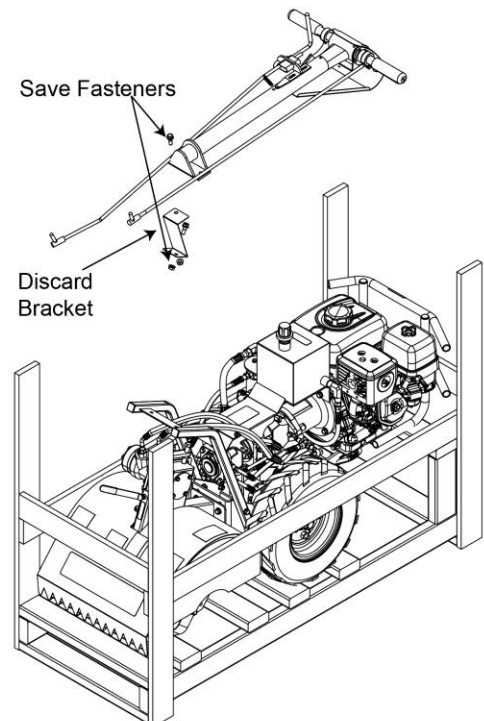
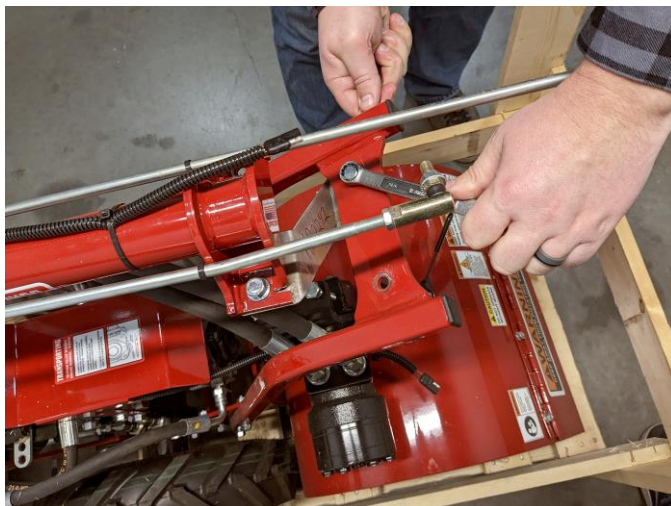

3.1 Assemble Handle

Bolt Upper Handle assembly to the Lower Handle assembly. Slide Tine control and Wheel control rods through handle bracket and fasten below Lower Handle assembly using bolts from crate bracket.

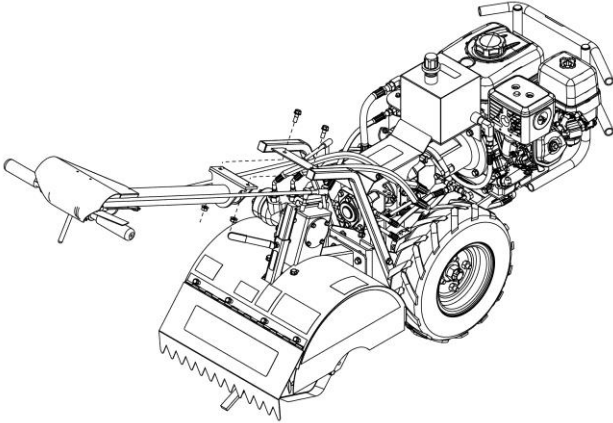

3.2 Attach Drive Rods

Attach Wheel Drive rod end and Tine Drive rod end as shown.

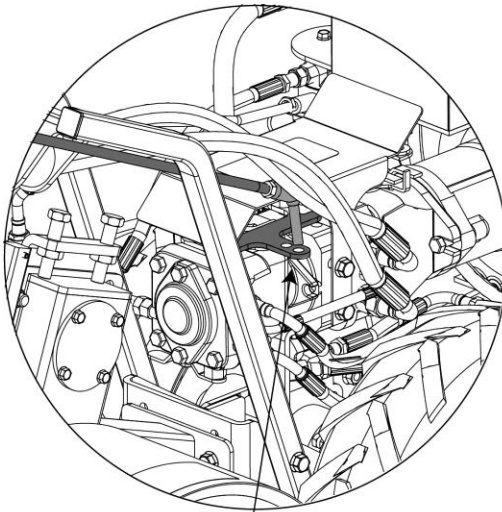

Install Wheel Control Rod
Into Bracket on right side

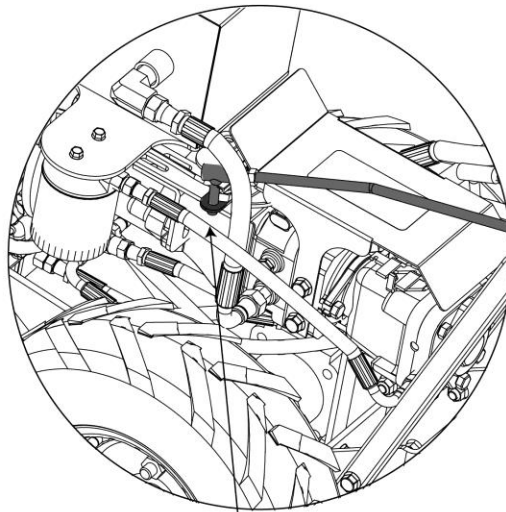

Install Tine Control Rod
Into Bracket on left side



3.3 Install Spring

Install Tine Control Rod spring.



3.4 Plug In Wire Harness

Plug in control wire harness between handle and main unit.



4 PARTS BREAKDOWN

4.1 Chaincase Breakdown

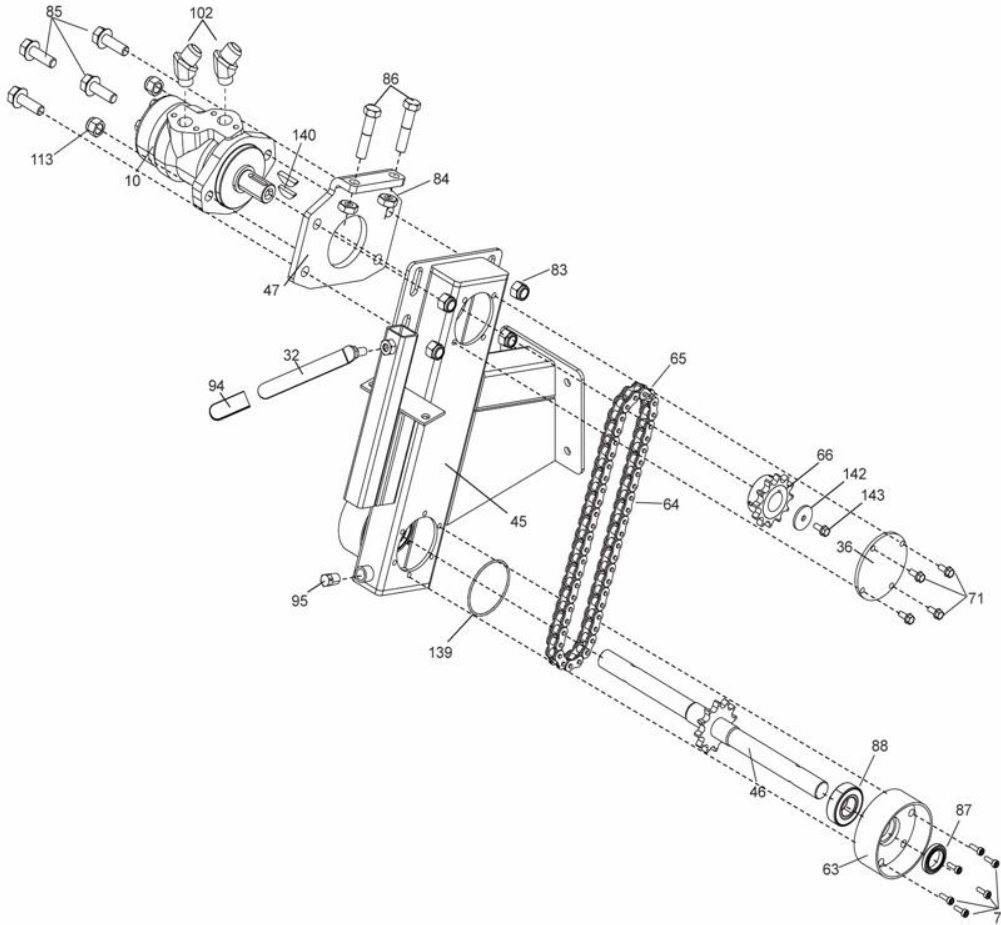

Ref	Part #	Description	Qty
10	1110005.MAX	Hydrostatic Motor, Tine Drive Danfoss	1
32	1110036.MAX	Tightener, depth Bar	1
36	1110040.MAX	Cover Plate, Chaincase	1
45	1110049.MAX	Chaincase Weldment	1
46	1110050.MAX	Tine Shaft, W/Sprocket	1
47	1110051.MAX	Tine Motor Bracket, Chain Tensioner	1
63	1110067.MAX	Bearing Holder, Tilling Tine Shaft	2
64	1110068.MAX	Drive Chain, #50, 49 Links	1
65	1110069.MAX	Master Link, #50 Chain	1
66	1110070.MAX	Tine Chain Drive Sprocket, 50 x 12T-1" Bore	1
71	1110075.MAX	Serrated Flange Bolt 1/4-20 x 1/2"	5
72	1110076.MAX	Bolt, 1/4 x 5/8 Soc Head	12
83	1110087.MAX	Serrated Flange Nut, 1/2-13	4

Ref	Part #	Description	Qty
84	1110088.MAX	Jamb Nut, 1/2-13	2
85	1110089.MAX	Flange Head Bolt, 1/2-13 x 1-1/2"	4
86	1110090.MAX	Hex Head Bolt, 1/2-13 x2 Full Thread	2
87	1110091.MAX	Oil Seal, Tine Shaft	2
88	1110092.MAX	Shaft Bearing,	2
94	1110098.MAX	Sleeve, Depth Bar Tightener Handle, 1/8 x 3/4"	1
95	1110099.MAX	Hex Head Pipe Plug, 1/4" NPT	1
102	1110106.MAX	Fitting, 6802-8-10, 45°, Tine Motor	2
113	1110117.MAX	Nylon Lock Nut, 1/2-13	6
139	1110143.MAX	O-ring	2
140	1110006.MAX	¼ inch woodruff key	1
142	1110150.MAX	¼ Oversized Washer	1
143	1110149.MAX	¼ -20 x ¾ Flange Bolt	1

4.2 Tines Breakdown

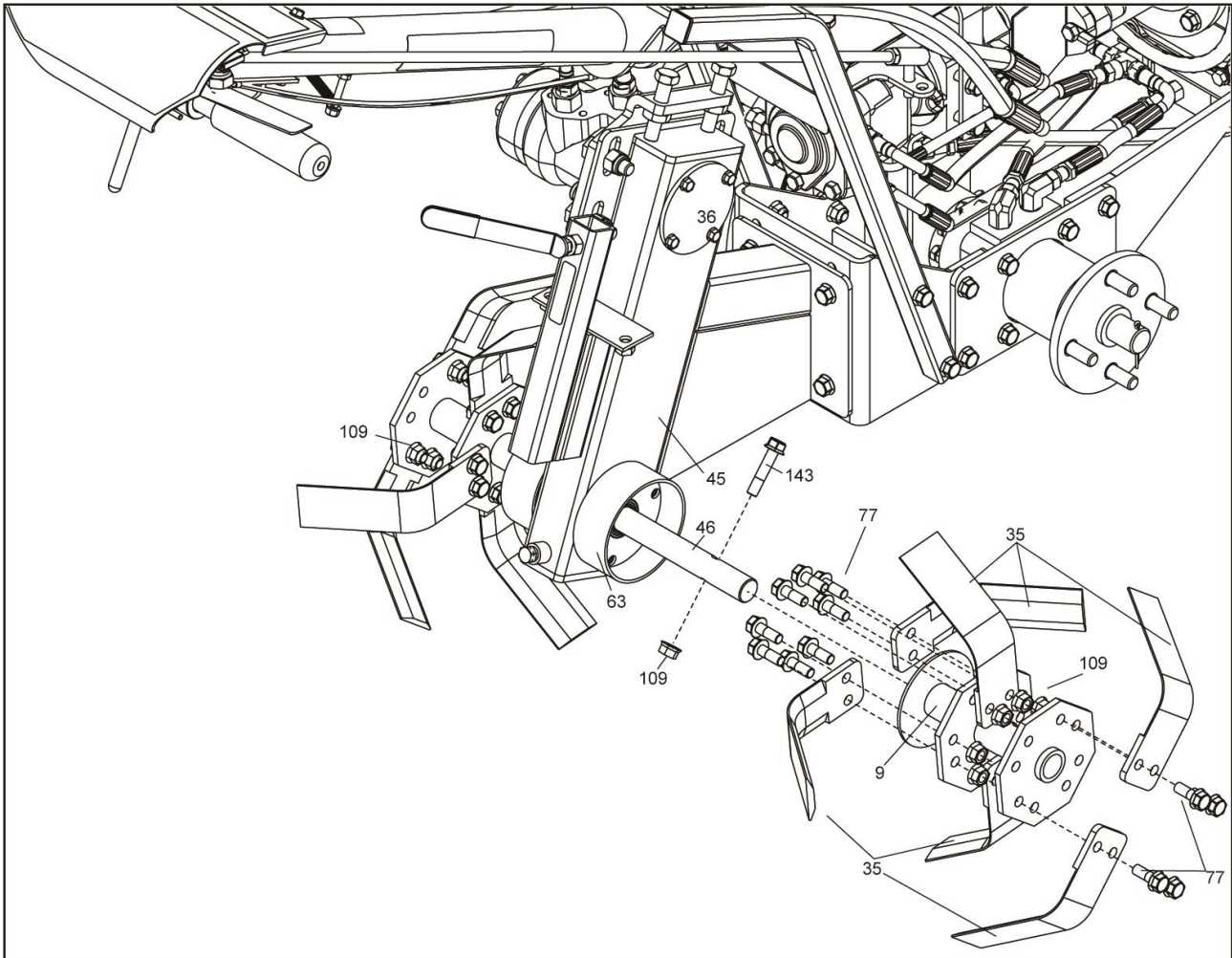

Ref #	Part #	Description	Qty
9	1110013.MAX	Tine Tube Bracket Assembly	2
35	1110039.MAX	Tilling Tine	12
36	1110040.MAX	Cover Plate, Chaincase	1
45	1110049.MAX	Chaincase Weldment	1
46	1110050.MAX	Tine Shaft, W/Sprocket	1
63	1110067.MAX	Bearing Holder, Tilling Tine Shaft	2
77	1110081.MAX	Serrated Flange Bolt 3/8-16 x 1"	24
109	1110146.MAX	3/8-16 Locking Nut	26
143	1110147.MAX	Hex Head Cap Screw Grade 5 3/8-16 x 1-3/4"	2

4.3 Main Unit Breakdown

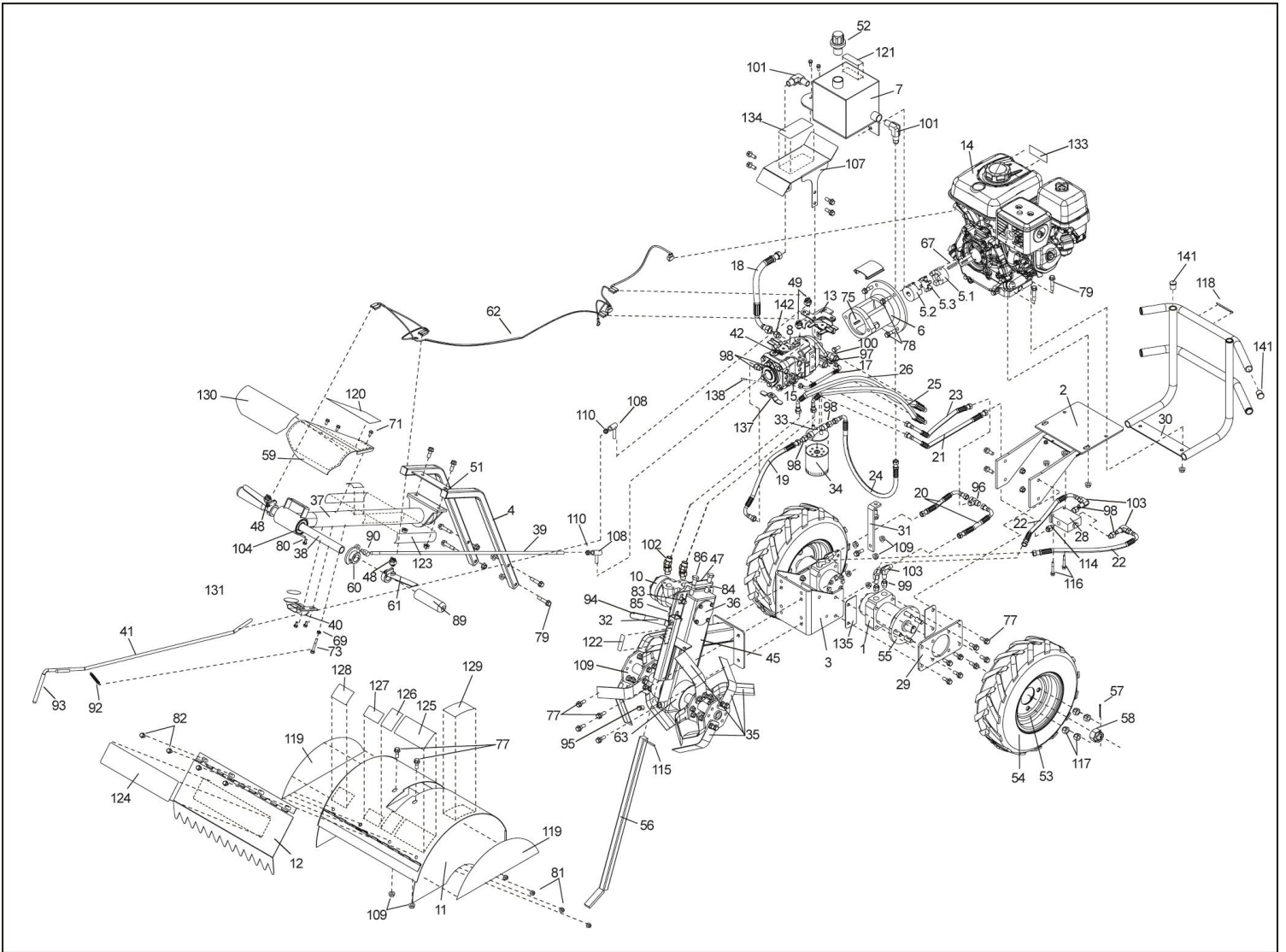



MRT190H

Ref	Part #	Description	Qty
1	1110001.MAX	Wheel Motor, Danfoss	2
2	1110002.MAX	Engine Mount Bracket Weldment	1
3	1110003.MAX	Frame Bracket, Rear	1
4	1110004.MAX	Lower Handle	2
5.1	BR006001C	Lovejoy Coupler 1"	1
5.2	BR006001F	Lovejoy Coupler 5/8"	1
5.3	BR006001B	Spider, Lovejoy	1
6	1110008.MAX	Pump, Mount	1
7	1110009.MAX	Hydraulic Oil Tank	1
8	1110011.MAX	Tandem Pump Assembly	1
9	1110013.MAX	Tine Tube Bracket Assembly	2
10	1110005.MAX	Hydrostatic Motor W/ Woodruff Key	1
11	1110015.MAX	Guard, Tiller tines	1
12	1110016.MAX	Flap, Tine Guard	1
13	1110017.MAX	Bracket, Safety Switch -Tine Drive Pump	1
14	GX270UT2QAG2	Engine, Honda GX270UT2QAG2	1
15	1110019.MAX	Fitting, 6400-4-2 - Pump to Pump	2
17	1110021.MAX	Hose, 1/4" Connecting Pump to pump	1
18	1110148.MAX	Hose, 3/8 x 11" Tank Return	1
19	1110023.MAX	Hose, 3/8 x 13.25 Filter to Wheel Pump - Supply	1
20	1110024.MAX	Hose, 3/8 x 6.5" Tee to Wheel Motor	2
21	1110025.MAX	Hose, 3/8 x 17.75" Wheel Pump To Flow Divider	1
22	1110026.MAX	Hose, 3/8 x 22.75" Flow Divider to Wheel Motor	2
23	1110027.MAX	Hose, 3/8 x 22.75" Wheel Pump to Tee	1
24	1110028.MAX	Hose, 3/8 x 21.75 Tank outlet to Filter	1
25	1110029.MAX	Hose, 1/2 x 21.13" Tine Pump to Tine Motor (Front Port)	1
26	1110030.MAX	Hose, 1/2 x 23.13" Tine Pump to Tine Motor (Back Port)	1
28	1110032.MAX	Flow Divider	1
29	1110033.MAX	Motor Mount, Wheel	2
30	1110034.MAX	Bumper Weldment	1
31	1110035.MAX	Pump Support Bracket, Rear	1
32	1110036.MAX	Tightener, depth Bar	1
33	1110037.MAX	Filter Head	1
34	1110038.MAX	Filter, Hydraulic Oil	1
35	1110039.MAX	Tilling Tine	12
36	1110040.MAX	Cover Plate, Chaincase	1

Ref	Part #	Description	Qty
37	1110041.MAX	Main Handle Weldment	1
38	1110042.MAX	Handle Bar	1
39	1110043.MAX	Wheel Drive Control Rod	1
40	1110044.MAX	Tine Engagement Control Bracket	1
41	1110045.MAX	Tiller Tine Engagement Control Rod	1
42	1110046.MAX	Plate, Safety Switch & Reverse; Wheel Pump	1
43	1110047.MAX	Drive Safety Switch Plate, Neutral control	1
44	1110048.MAX	Bracket, Safety Flat	1
45	1110049.MAX	Chaincase Weldment	1
46	1110050.MAX	Tine Shaft, W/Sprocket	1
47	1110051.MAX	Tiller Tine Motor Bracket, Chain Tensioner	1
48	1110052.MAX	Safety Switch, Handlebar (Black)	2
49	1110053.MAX	Safety Switch, Neutral (white)	2
50	1110054.MAX	Valve Stem	2
51	1110055.MAX	Tube Cover Plug, 1" Square	2
52	1110056.MAX	Hydraulic Tank Cap, Ventilated	1
53	1110057.MAX	Wheel, 8 x 3.76	2
54	1110058.MAX	Tire, 480 x 8, 4 ply	2
55	1110059.MAX	Hub, Drive Wheel	2
56	1110060.MAX	Tilling depth Adjustment Bar	1
57	1110061.MAX	Cotter Pin, 1/8 x 1 1/4"	2
58	1110062.MAX	Castle Nut, 3/4"	2
59	1110063.MAX	Handle Bar Cover	1
60	1110064.MAX	Drive Control Stop Collar	1
61	1110065.MAX	Drive Control safety Paddle	2
62	1110066.MAX	Wire Harness, safety Switches	1
63	1110067.MAX	Bearing Holder, Tilling Tine Shaft	2
64	1110068.MAX	Drive Chain, #50, 49 Links	1
65	1110069.MAX	Master Link, #50 Chain	1
66	1110070.MAX	Tine Chain Drive Sprocket, 50 x 12T-1" Bore	1
67	1110071.MAX	1/4" Key	1
68	1110072.MAX	1/4-20 Nylon Locknut	1
69	1110073.MAX	Serrated Flange Nut 1/4-20	3
71	1110084.MAX	Machine Screw, #12 x 3/4" Self-tapping	3
72	1110076.MAX	Bolt, 1/4 x 5/8 Soc Head	12
73	1110077.MAX	Serrated Flange Bolt 1/4-20 x 1-1/4"	1
74	1110078.MAX	Carriage Bolt 1/4-20 x 3 1/4"	2
75	1110079.MAX	3/16" Key	1



4.4 General Information

Engine	Honda GX270
Transmission	Hydro/Wheel Motors
Tine speed (max)	300 RPM Dual Rotating
Tines	Replaceable, bolt on
Tilling width	18"
Tilling depth	8"
Drag Bar	Adjustable
Handles	Adjustable
Tires	4.80/4.00-8
Dimensions (L x W x H)	69" x 21" x 42"
Shipping weight	315 lbs.

5 Final Set-up

Engine Oil:

- The engine of your unit has been shipped, from the factory, already filled with SAE 30 summer weight oil.
- With engine level, clean area around oil filler plug and remove plug.
- Engine oil should be filled to the top of the filler plug when engine is level.
- For oil specifications and capacity see your Honda engine manual shipped with unit.
- Reinstall engine oil cap and tighten.
- To change engine oil, see the Maintenance section in this manual.

Hydraulic Oil:

- The Hydraulic oil reservoir of your unit has been shipped, from the factory, already filled with Chevron Delo 400 5w-40 Synthetic Oil Hydraulic oil.
- To check level, unscrew the Hydraulic Oil reservoir fill plug from the top of the Hydraulic reservoir. Correct level should be approx. 1" inch below the top of the reservoir tank.
- Capacity approx. one gallon.

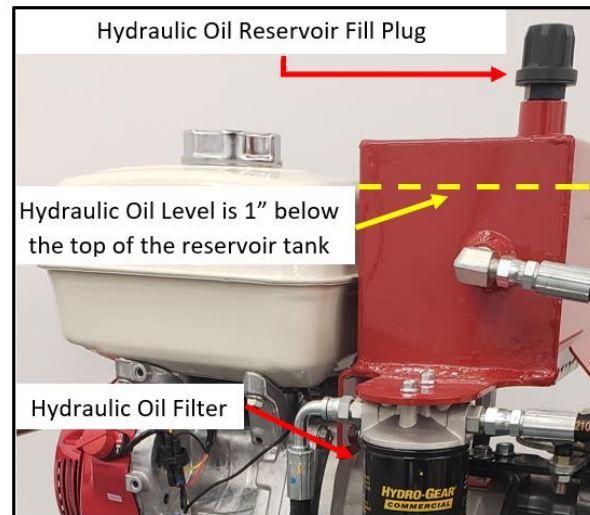
**Fuel:**

- Fill the fuel tank. Use clean, fresh, lead-free gasoline. **DO NOT MIX OIL WITH GASOLINE.**
- Fill fuel tank to bottom of filler neck. Do not overfill. Use fresh, clean, regular unleaded gasoline with a minimum of 87 octane. (Use of leaded gasoline will increase carbon and lead oxide deposits and reduce valve life). Do not mix oil with gasoline. Purchase fuel in quantities that can be used within 30 days to assure fuel freshness.

**⚠ CAUTION**

CAUTION: Fill to within 1/2 inch of top of fuel tank to prevent spills and to allow for fuel expansion. If gasoline is accidentally spilled, move machine away from area of spill. Avoid creating any source of ignition until gasoline vapors have disappeared.

Wipe off any spilled oil or fuel. Do not store, spill, or use gasoline near an open flame.

Gasoline is highly flammable and explosive, you can be burned or seriously injured when handling fuel. Use extreme care when handling gasoline or other fuels. They are flammable and vapors are explosive.

6 OPERATING CONTROLS

CAUTION

Keep tine control rod in “DISENGAGED” position when starting engine.

6.1 To Start Engine

When starting the engine for the first time or if engine has run out of fuel it will take extra pulls of the recoil starter to move fuel from the tank to the engine.

1. Make sure spark plug wire is properly connected.
2. Place throttle control, located on engine, in “FAST” position.
3. Turn fuel shut-off valve, located on engine, to open position.
4. Move choke control, located on engine, to closed choke position.
5. Grasp recoil starter handle with one hand and place foot on bottom part of front bumper. Pull rope out slowly until engine reaches start of compression cycle (rope will pull slightly harder at this point).
6. Pull recoil starter handle quickly. Do not let starter handle snap back against starter.
7. If engine fires but does not start, move choke control to half choke position. Pull recoil starter handle until engine starts.
8. When engine starts, slowly move choke control to “RUN” position as engine warms up.
9. Move throttle control, located on engine, to desired running position.
10. Allow engine to warm up for a few minutes before engaging tines.

CAUTION

READ THIS OWNER’S MANUAL AND SAFETY RULES BEFORE OPERATING YOUR TILLER.

Compare the illustrations with your tiller to familiarize yourself with the location of various controls and adjustments. Save this manual for future reference.

7 MACHINE IDENTIFICATION COMPONENTS

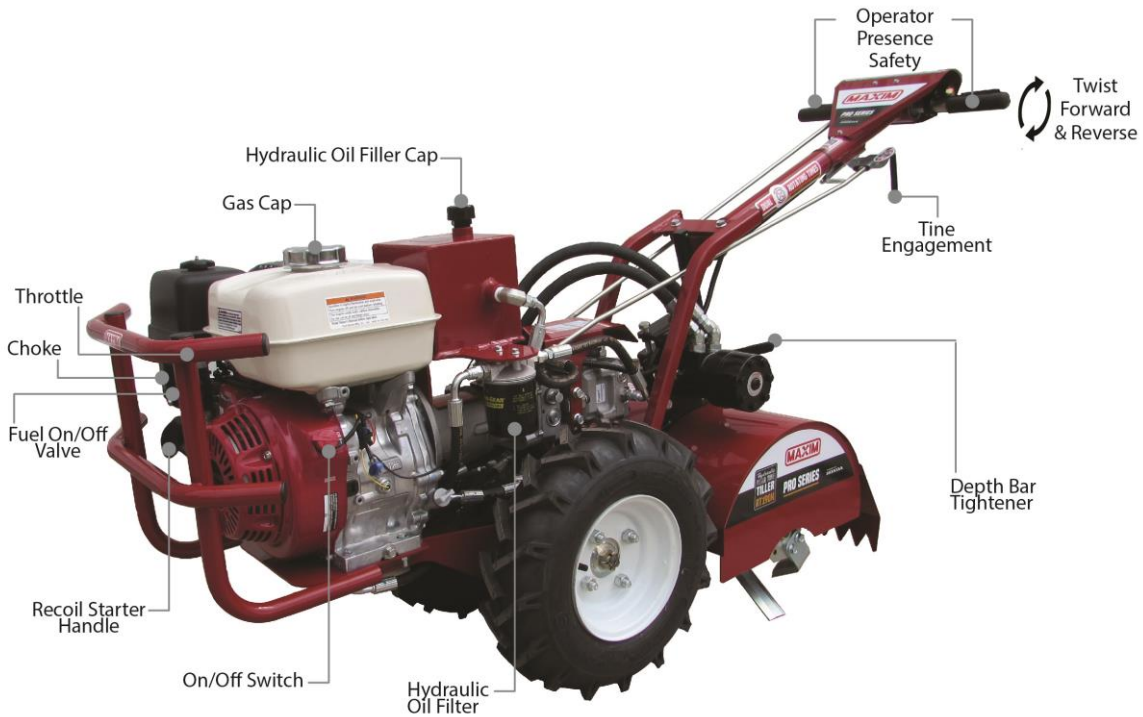

8 OPERATION

8.1 Drive operation

1. With hands on handlebar, gripping the micro safety switch tabs, unit can be operated in forward/reverse along with tine operation.
2. Twist handlebar control forward for Forward drive, twist control backward for Reverse drive. Center control for Neutral operation.

8.2 Tine operation

Tine movement is achieved by pulling tine control rod back for counter rotating tilling or push forward for forward rotation tilling. To lock in either position, move control rod towards the center.

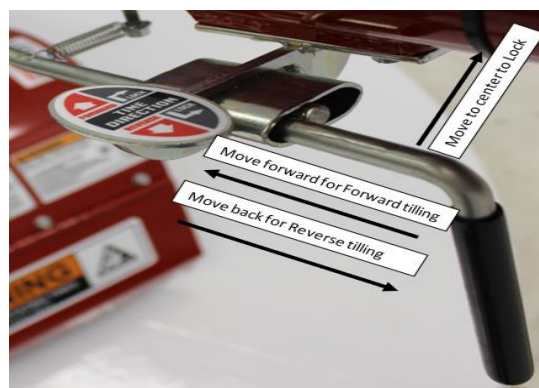

8.3 Safe operation while tilling

1. Engage Tine direction for Forward rotation or Reverse rotation and twist handlebar forward to begin tilling.
2. With Tine direction in neutral, Twist handlebar towards the operator, to reverse movement of tiller.

Note: Engine will shut off, if tines are engaged and handle is twisted to move the tiller in reverse.



CAUTION

Until you are accustomed to handling your tiller, start actual field use with throttle in slow position (midway between "FAST" and "IDLE").

8.4 Depth Bar Stake

1. The Depth Bar Stake be raised or lowered, to allow you more versatile tilling and cultivating or to transport your tiller using the power of the Hydraulics more easily.
3. Loosen Depth Bar tightener, pull the Depth Bar up for increased tilling depth. Place the Depth Bar to the desired height position and retighten tightener handle to lock into position.
4. Place tine control rod in desired position/rotation. Slowly lower tines into the ground. Twist handlebar forward to desired speed
5. Move throttle control to "FAST" position for deep tilling. To cultivate, throttle control can be set at any desired speed, depending on how fast or slow you wish to cultivate.



Depth Bar

Depth Bar Tightener Handle

8.5 Turning sharply

1. Disengage the Tine Control Rod
2. Move throttle control to "Slow" position.
3. Lift handle to raise tines out of ground.
4. Swing the handle in the opposite direction you wish to turn, being careful to keep feet and legs away from tines. Slowly twist handlebar to desired direction.
5. When you have completed your turn-around, with handle up and tines out of ground, again engage tines in desired direction. Slowly lower handle to start tilling. Slowly twist handlebar forward to desired speed.

8.6 Tilling

- Tilling is digging into, turning over, and breaking up packed soil before planting. Loose, unpacked soil helps root growth. Best tilling depth is 4" to 6" (10-15 cm). A tiller will also clear the soil of unwanted vegetation. The decomposition of this vegetable matter enriches the soil. Depending on the climate (rainfall and wind), it may be advisable to till the soil at the end of the growing season to further condition the soil.
- You will find tilling much easier if you leave a row un-tilled between passes. Then go back between tilled rows. (See Fig. 15) There are two reasons for doing this. First, wide turns are much easier to negotiate than about-faces. Second, the tiller will not be pulling itself, and you, toward the row next to it.
- Soil conditions are important for proper tilling. Tines will not readily penetrate dry, hard soil which may contribute to excessive bounce and difficult handling of your tiller. Hard soil should be moistened before tilling; however, extremely wet soil will "ball-up" or clump during tilling. Wait until the soil is less wet, in order to achieve the best results. When tilling in the fall, remove vines and long grass to prevent them from wrapping around the tine shaft and slowing your tilling operation.
- Do not lean on handle. This takes weight off the wheels and reduces traction. To get through a tough section of sod or hard ground, apply downward pressure on handle or raise the depth bar.

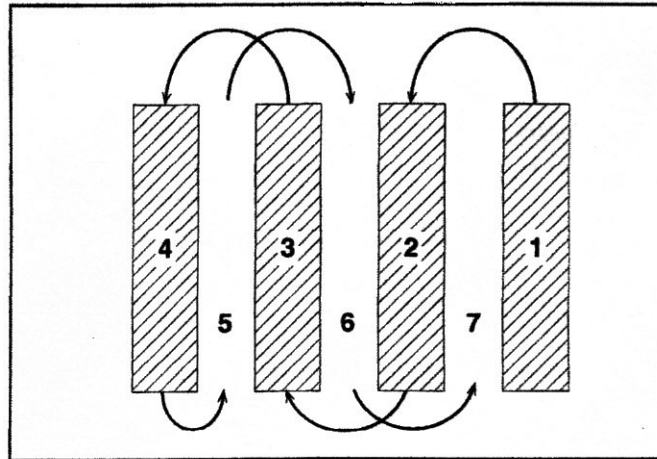

FIG. 15

8.7 Cultivating

- Cultivating is destroying the weeds between rows to prevent them from robbing nourishment and moisture from the plants. At the same time, breaking up the upper layer of soil crust will help retain moisture in the soil. Best digging depth is 1" to 3" (2.5 - 7.5 cm).
- Cultivate up and down the rows at a speed which will allow tines to uproot weeds and leave the ground in rough condition, promoting no further growth of weeds and grass.
- Do not lean on handle, this takes weight off the wheels, reduces traction, and may cause the tiller to skip over the ground.
- **Always lower the depth bar when using the forward rotating tine drive**

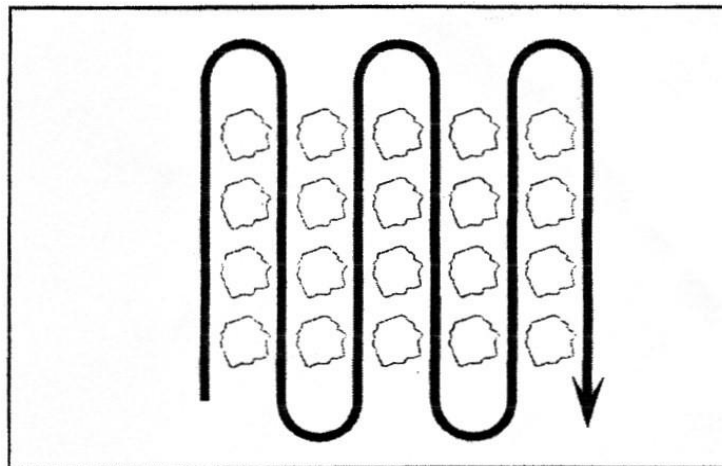
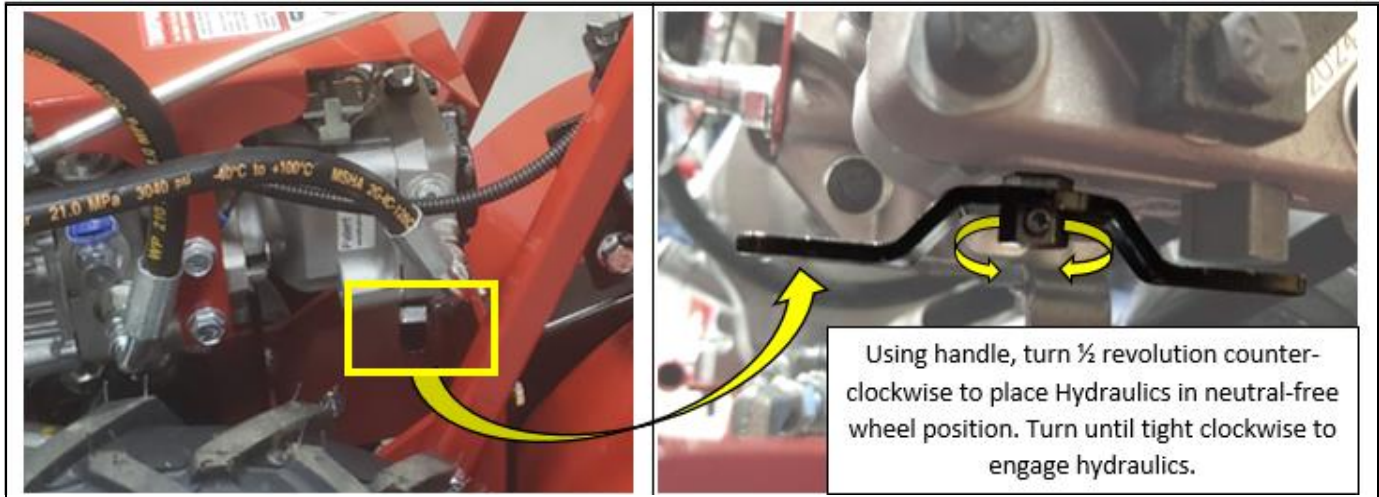

FIG. 16

9 Transporting – pushing tiller without engine running/power

9.1 Hydraulic Pump Lock Out/Release

1. On the bottom side of the Hydraulic Pump locate the turn valve handle.
2. Using handle turn ½ revolution counter-clockwise to place Hydraulics in neutral-free wheel position. Turn until tight clockwise to re-engage hydraulics.



10 MAINTENANCE AND LUBRICATION

- The warranty on this tiller does not cover items that have been subjected to operator abuse or negligence. To receive full value from the warranty, the operator must maintain tiller as instructed in this manual.
- Some adjustments will need to be made periodically to properly maintain your tiller.
- All adjustments in the Service and Adjustments section of this manual should be checked at least once each season.
- BEFORE EACH USE
 1. Check engine oil level. See page 33.
 2. Check tine operation.
 3. Check for loose fasteners.

10.1 Cleaning

⚠ IMPORTANT: If the engine has been running, allow it to cool for at least half an hour before washing.

1. Wash the tiller, including the underside, after use.
2. Use Compressed air and/or Wash the engine by hand and be careful to prevent water or debris from entering the air cleaner.

⚠ NOTE: Do not use a garden hose or pressure washing equipment, it can force water into the air cleaner. Water in the air cleaner will soak the filter element and can enter the carburetor or engine cylinder, causing damage.

3. After washing the tiller, wipe dry.
4. After the tiller is clean and dry, touch up any damaged paint and coat other areas with a light film of oil.
5. Wipe the tines with oil or spay to prevent rusting.

10.2 Cleaning the Cooling System

1. Remove blower housing and clean regularly.

⚠ NOTE: Grass or chaff may clog cooling system after prolonged service. Continued operation with a clogged cooling system causes severe overheating and possible engine damage.

10.3 Dual Filter Element Air Cleaner

Air Cleaner Check/Cleaning and Replacement

Dual Element Type:

A dirty air filter will restrict air flow to the carburetor reducing engine performance. If the engine is operated in dusty areas, clean the air cleaner more often than specified in the MAINTENANCE SCHEDULE.

Operating the engine without the air filters or with the filters installed loosely, will allow dirt to enter the engine, causing rapid engine wear. Install the air filter securely.

1. Remove the nut (1) and the air cleaner cover (2).
2. Remove the wing nut (3) and the air filter assembly (4-5)
3. Separate the inner filter (Paper) (4) from the outer filter (foam) (5). Carefully check both filters for holes or tears and replace if damaged.
4. Clean filters if they are to be reused.
5. Install the elements in the reverse order of removal.

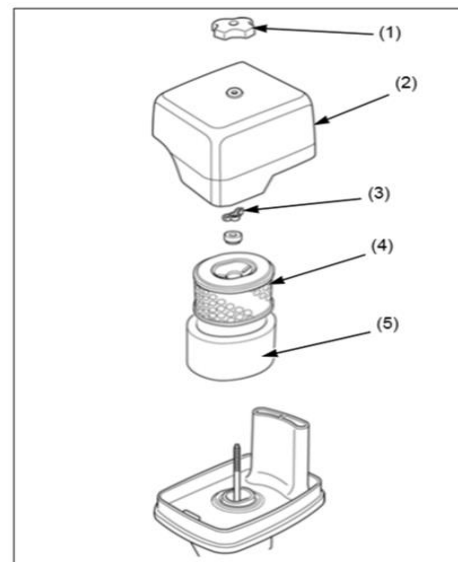

10.4 Engine Oil – 1.16 quart, (38.63 oz)

Use only high-quality detergent oil related with API service classification SG, SF/CC, CDL. Select the oil's SAE viscosity grade according to your expected temperature.

Check engine oil level before each use.

Change the oil after the first 20 hours of operation and then every 100 hours after than or at least twice a year.

TO CHANGE ENGINE OIL

- 1 Be sure engine is off and level.
- 2 Oil will drain more freely when warm.
- 3 Use a funnel to prevent oil spill and catch oil in a suitable container.
- 4 Remove drain plug.
- 5 For easier removal of plug use 7/16 12 Pt. socket with extension.
- 6 After oil has drained completely, replace oil drain plug and tighten securely at 13 ft-lbs.
- 7 Remove oil filler plug. Be careful not to allow dirt to enter the engine.

Refill engine with recommended oil to the upper level of the oil filler neck.

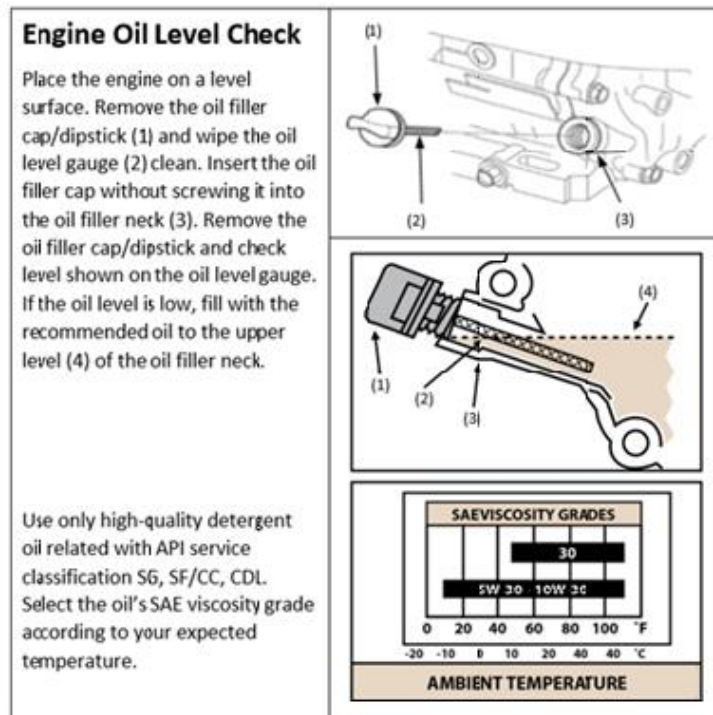

10.5 Hydraulic Oil - Capacity is approx. one gallon.

1. The Hydraulic oil reservoir of your unit has been filled with Chevron Delo 400 5w-40 Synthetic Oil Hydraulic oil.
2. To check level, unscrew the reservoir fill plug from the top of the tank. Correct level should be to the bottom of the oil fill tube inside tank approx. 1" inch as seen below.

TO CHANGE HYDRAULIC OIL:

1. Be sure unit is off and level.
2. Oil will drain more freely when warm.
3. Disconnect the hose at Filter, shown below.
4. Lower hose and drain into a suitable container.
5. Remove Hydraulic Oil filter and replace every 25 hours.
6. Once drained, replace with new filter, and re-connect Hydraulic line.
7. Refill reservoir to the level as noted below, with fresh Hydraulic oil every season.
8. Turn Hydraulic Release handle, counter-clockwise (open position/ bypass)
9. Start engine and run at low rpm.
- 1 To purge system, rotate controls on handlebar, forward and backward 10 times.

- 2 Turn Hydraulic Release handle clockwise (closed position) to re-engage hydraulics.
- 3 Verify hydraulics are working by rotating hand controls on handlebar, forward and backwards multiple times each direction.
- 4 Stop engine and check hydraulic oil level and top off if needed, not to exceed 1" from the top of reservoir as indicated below.

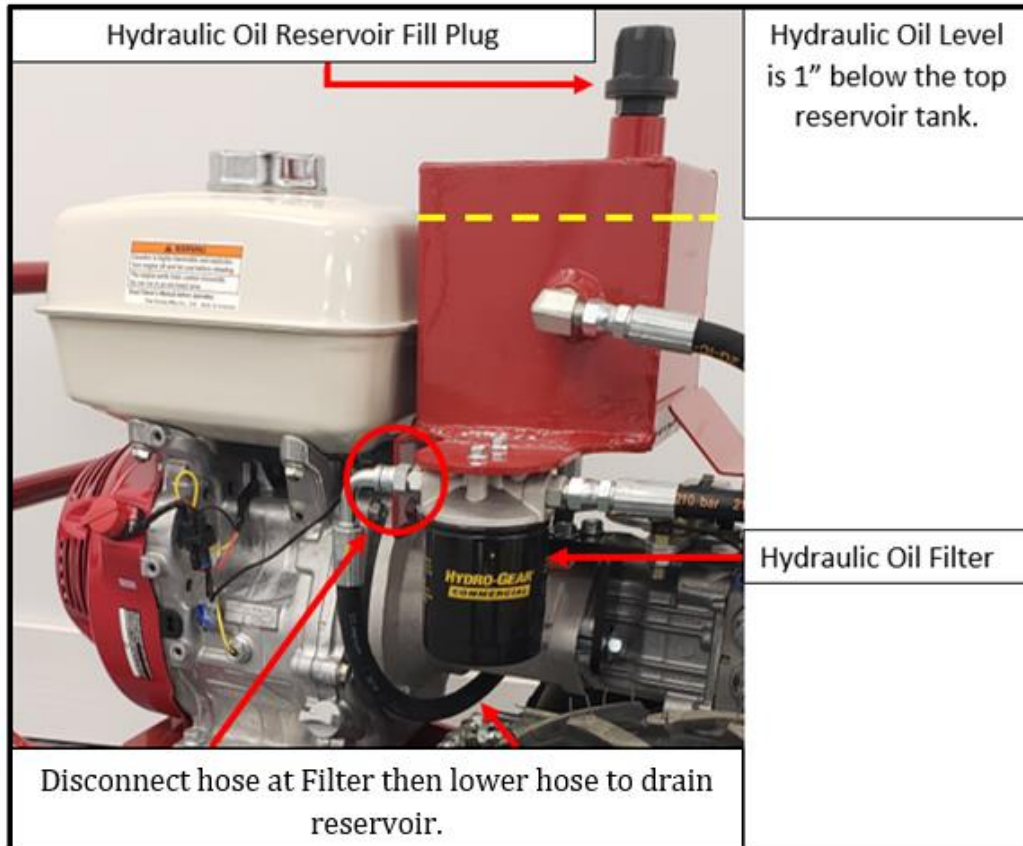

10.6 Tine Chain Case

Tine Chain Case Oil:

1. The Tine Chain Case reservoir of your is shipped, from the factory, filled with #80W-90 weight Gear oil.
2. Approx. capacity 1/3 quart, 10.5 ounces

To check Tine Chain Oil level:

1. Remove four bolts from top inspection cover and remove.
2. Inspect coverage of oil on chain inside and ensure that oil is traveling up the chain and is clearly visible on chain, when viewing through inspection cover.
3. Remount cover

To change Tine Chain Oil:

1. Remove four bolts from top inspection cover and remove.
2. Remove lower Tine Chain Case oil plug and drain.
3. Re-install oil plug
4. Fill with #80W-90 weight Gear oil, approximately 1/3 quart, 10.5 ounces through inspection cover opening.
5. Remount Inspection cover with original mounting hardware.

To adjust and check tension of Tine Chain:

1. Remove four bolts from top inspection cover and remove.
2. Use the adjustment bolts on top of case to adjust tension of chain.
3. Deflection of chain should be no more than 1/8"
4. Caution must be taken to not overtighten chain.
5. Remount Inspection cover with original mounting hardware.

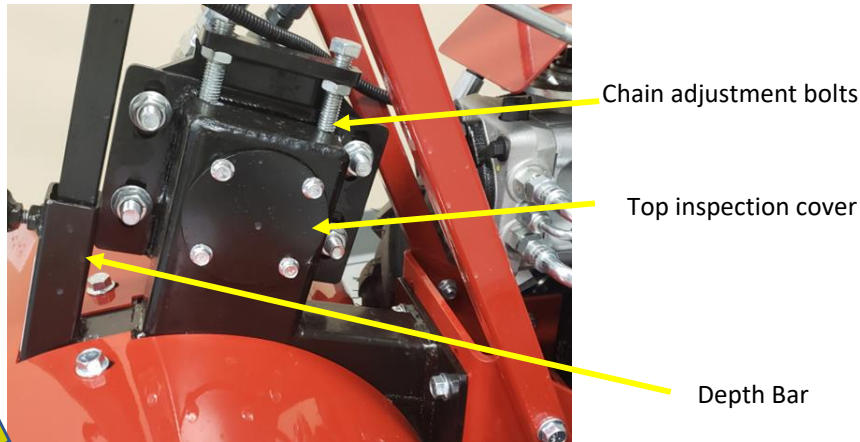

Under side of Tiller Tine/Shroud

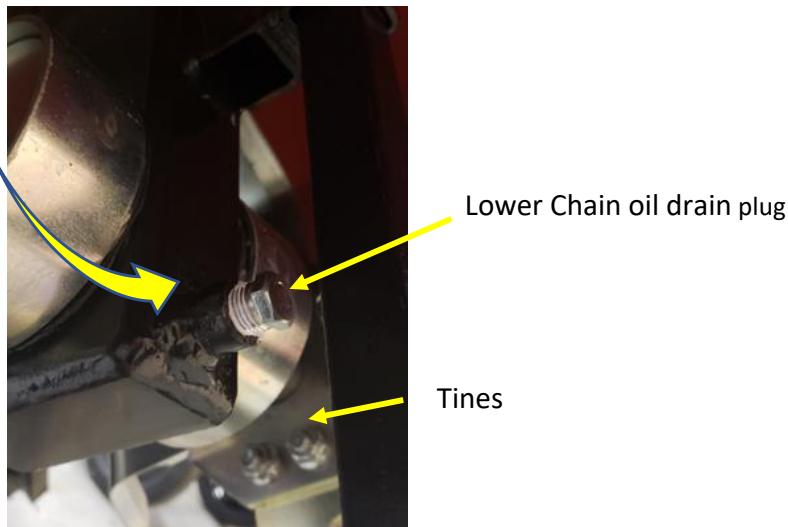
**10.7 Muffler**

Do not operate tiller without muffler. Do not tamper with exhaust system. Damaged mufflers or spark arresters could create a fire hazard. Inspect periodically and replace if necessary. If your engine is equipped with a spark arrester screen assembly, remove every 50 hours for cleaning and inspection. Replace if damaged.

10.8 Spark Plug

Replace spark plugs at the beginning of each tilling season or after every 50 hours of use, whichever comes first. Spark plug type and gap setting is to .030" / 0.76mm

11 Tire Care

- Maintain 39 pounds of tire pressure. If tire pressures are not equal, tiller will pull to one

- side.
- Keep tires free of gasoline or oil which can damage rubber.

	<p>CAUTION: When mounting tires, unless beads are seated, over-inflation can cause an explosion.</p>
---	---

11.1 Maintenance Schedule

MAINTENANCE									
MAINTENANCE SCHEDULE	BEFORE EACH USE	EVERY 5 HOURS	EVERY 25 HOURS	EVERY 50 HOURS	EVERY 100 HOURS or ONCE PER YEAR	FILL IN DATES AS YOU COMPLETE REGULAR SERVICE			
						Service Dates			
Check Engine Oil	X	X							
Change Engine Oil			X						
Check Hydraulic Oil Level	X								
Inspect Spark Arrester/Muffler				X					
Inspect Air Screen	X								
Clean or Replace Air Cleaner Cartridge				X					
Clean Engine Cylinder Fins				X					
Replace Spark Plug				X					
Change Hydraulic Oil					X				
Check Tine Chain Tension			X						
Check Tine Chain Oil				X					
Change Tine Chain Oil					X				
Change Hydraulic Oil Filter			X						

12 WARRANTY

12.1 Warranty/Product Registration

Please register your product immediately after purchase. You can do that by visiting our website at www.maximmfg.com and complete our online product registration.

Or complete the following warranty/production registration form on the next page and return to:

Maxim
Attn: Warranty Registration Department
20195 South Diamond Lake Road, STE 100
Rogers, MN 55374



MRT190H

Product Registration Form

YOUR INFORMATION

Full Name:

Last

First

M.I.

Address:

Street Address

Apartment/Unit #

City

State

ZIP Code

Home Phone:

Alternate
Phone:

Email

PURCHASED FROM

Company:

Address:

Street Address

Apartment/Unit #

City

State

ZIP Code

MODEL INFORMATION

Purchase Date

Application Type

Homeowner

Commercial

Rental

Model (i.e. RMT55H)

Serial # (i.e. RMT55HA01234567)

Signature

Register your product online at www.maximmfg.com

Or Fax completed form to 763-428-4821



20195 South Diamond Lake Road, Suite 100 • Rogers, MN 55374
 Toll-Free: 800-621-2789 • Website: maximmfg.com • Email: sales@maximmfg.com

Dear Valued Customer:

The Maxim Product you just purchased is built with the finest material and craftsmanship. Use this product properly and enjoy the benefits from its high performance. By purchasing a Maxim Product, you show a desire for quality and durability. Like all mechanical equipment this unit requires a due amount of care. Treat this unit like the high quality piece of machinery it is. Neglect and improper handling may impair its performance and is not covered by this limited warranty.

Thoroughly read the instructions and understand the operation before using your product. Always contact Maxim Product Support at 1-800-621-2789 prior to having any service or warranty work performed, as some services performed by parties other than Maxim approved service centers may void this warranty. This limited warranty is in lieu of any other warranty expressed or implied, written or oral and Maxim assumes no other responsibility or liability outside that expressed within this limited warranty.

**Limited Warranty for Maxim Hydraulic Rear Tine Tiller:
RT190H**

	Consumer Warranty Period	Commercial Warranty Period
Weldments	1 year from date of purchase by user	1 year from date of purchase by user
Hydro-Gear	1 year from date of purchase by user	1 year from date of purchase by user
Wear Parts	Maxim shall warrant some normal wear items from defects in material or workmanship for a period of 30 days from the date of purchase by user. Unless unused, warranty does not apply to normal wear and tear components including, but not limited to, High impact wear related components such as tines and tine assemblies, seals, seal shields, bearings, bushings, gaskets, tires, wheel assemblies and lubrication to include hydraulic oil replacement, fuel contamination or from failure to follow instructions contained in the User Manual for the equipment. Wear item warranties are subject to inspection, with warranty level of coverage or to replace/repair is at the sole decision/discretion of Maxim. Routine maintenance items such as lubricants, adjustments, tune ups, and/or damage from operation with loose hardware are not covered under limited warranty.	
Engines	The engine warranty is covered under the terms and conditions as outlined by the engine manufactures warranty contained herein and is the sole responsibility of the engine manufacturer. Normal engine maintenance such as spark plugs, oil changes, filters, adjustments, fuel system cleaning and obstruction due to build up is not covered by this Maxim limited warranty.	

“**Consumer use**” means personal residential household use by a consumer. “**Commercial use**” means all other uses, including, but not limited to, use for commercial, income producing or rental purposes or when purchased by a business.

This limited warranty applies to the original purchaser of the equipment (verification of purchase, in the form of a receipt, is the responsibility of the buyer), is non-transferable, and covers parts and labor. Parts will be replaced or repaired at no charge, except when the equipment has failed due to lack of proper maintenance. If a part is no longer available, the part may be replaced with a similar part of equal function. Any misuse, abuse, alteration or improper installation or operations will void warranty. Determining whether a part is to be replaced or repaired is the sole decision of Maxim. Maxim will not provide for replacement of complete products due to defective parts. Any costs incurred due to replacement or repair of items outside of a Maxim approved facility is the responsibility of the buyer and not covered under warranty. Transportation costs to and from service center and/or service calls are the responsibility of the customer.

This limited warranty specifically excludes the following; failure of parts due to damage caused by accident, fire, flood, windstorm, acts of God, applications not approved by Maxim in writing, corrosion caused by chemicals, use of replacement parts which do not conform to manufacturer’s specifications, damage related to rodent and/or insect infestation and damage caused by vandalism. Additional exclusions: loss of running time, inconvenience, loss of income, or loss of use, including any implied warranty of merchantability of fitness for a specific use. Also, outdoor power equipment needs periodic parts and service to perform well, and this limited warranty does not cover instances when normal use has exhausted the life of a component or the engine.

This limited warranty does not cover any personal injury or damage to surrounding property caused by failure of any part, misuse or inability to use the product. Alteration of the product, including safety features, shall void this limited warranty.



MRT190H



Maxim

A Brand of Great Northern Equipment Distributing, Inc.

20195 South Diamond Lake Road

Suite 100

Rogers, MN 55374

www.maximmfg.com

800-621-2789