

COZY ESCAPE PLAYHOUSE - F29045

INSTALLATION AND OPERATING INSTRUCTIONS



WARNING To reduce the risk of serious injury or death, you must read and follow these instructions. Keep and refer to these instructions often and give them to any future owner of this play set. Manufacturer contact information provided below.

OBSTACLE FREE SAFETY ZONE - 23' 7.5" x 20' 1.7" (720 x 677 cm) area requires Protective Surfacing. See page 3.

MAXIMUM VERTICAL FALL HEIGHT - 56-5/16" (1.43m)

CAPACITY - 11 Users Maximum, Ages 3 to 10; Weight Limit 110 lbs. (49.9 kg) per child.

RESIDENTIAL HOME USE ONLY. Not intended for public areas such as multi-unit residences, schools, churches, nurseries, day cares or parks. Warning. Only for domestic use.

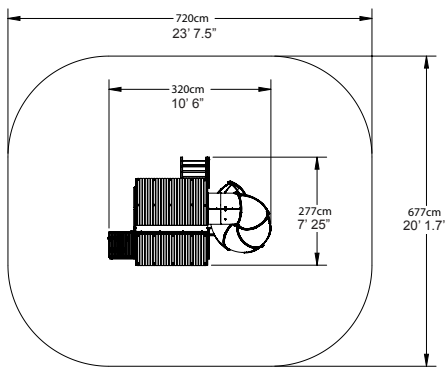

2 - 4 Hrs
FOR FORT
TWO PERSON
ASSEMBLY

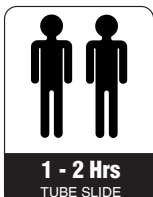

1 - 2 Hrs
TUBE SLIDE
TWO PERSON
ASSEMBLY

For Outdoor Family Domestic Use Only



KidKraft, Inc.
4630 Olin Road
Dallas, Texas 75244 USA
customerservice@kidkraft.com
canadacustomerservice@kidkraft.com
1.800.933.0771
972.385.0100
For online parts replacement visit
<https://parts.kidkraft.com/>

KidKraft Netherlands BV
Olympisch Stadion 8
1076 DE Amsterdam
The Netherlands
europecustomerservice@kidkraft.com
+31 20 305 8620 M-F from 09:00 to 17:30
(GMT+1)
For online parts replacement visit
<https://parts.kidkraft.eu/>

Table of Contents

Warnings and Safe Play Instructions.....	pg. 2
Protective Surfacing Guidelines.....	pg. 3
Instructions for Proper Maintenance.....	pg. 4
About Our Wood - Limited Warranty.....	pg. 5
Keys to Assembly Success.....	pg. 7
Part ID.....	pg. 8-14
Step-By-Step Instructions.....	pg. 15
Installation of I.D./Warning Plaque.....	Final Step
9409045	Rev 08/28/2020

Warnings and Safe Play Instructions



CONTINUOUS ADULT SUPERVISION REQUIRED. Most serious injuries and deaths on playground equipment have occurred while children were unsupervised! Our products are designed to meet mandatory and voluntary safety standards. Complying with all warnings and recommendations in these instructions will reduce the risk of serious or fatal injury to children using this play system. Go over the warnings and safe play instructions regularly with your children and make certain that they understand and follow them. Remember on-site adult supervision is required for children of all ages.



WARNING

SERIOUS HEAD INJURY HAZARD

Installation over concrete, asphalt, dirt, grass, carpet and other hard surface creates a risk of serious injury or death from falls to the ground. Install and maintain shock absorbing material under and around play-set as recommended on page 3 of these instructions.

COLLISION HAZARD

Place play-set on level ground at least 2m from any obstruction such as a garage or house, fences, poles, trees, sidewalks, walls, landscape timbers, rocks, pavement, planters, garden borders, overhanging branches, laundry lines, and electrical wires. (See OBSTACLE FREE SAFETY ZONE on cover)

CHOKING HAZARD/SHARP EDGES & POINTS

Adult assembly required. This product contains small parts and parts with sharp edges and points. Keep parts away from children until fully assembled.

WARNING LABEL

Owners shall be responsible for maintaining the legibility of the warning labels.

STRANGULATION HAZARD

- NEVER allow children to play with ropes, clotheslines, pet leashes, cables, chains or cord-like items when using this play-set or to attach these items to play-set.
- NEVER allow children to wear loose fitting clothing, ponchos, hoods, scarves, capes, necklaces, items with draw-strings, cords or ties when using this play-set.
- NEVER allow children to wear bike or sport helmets when using this play-set.

Failure to prohibit these items, even helmets with chin straps, increases the risk of serious injury and death to children from entanglement and strangulation.

TIP OVER HAZARD

Choose a level location for the equipment. This can reduce the likelihood of the play set tipping over and loose-fill surfacing materials washing away during heavy rains.

DO NOT allow children to play on the play-set until the assembly is complete and the unit is properly anchored.

Never add extra length to chain or rope. The chains or ropes provided are the maximum length designed for the swinging element(s).



WARNING – Safe Play Instructions

- ✓ Observe capacity limitations of your play-set. See front cover.
- ✓ Dress children with well fitting and full foot enclosing footwear.
- ✓ Teach children to sit with their full weight in the center of the swing seat to prevent erratic swing motion or falling off.
- ✓ Check for splintered, broken or cracked wood; missing, loose, or sharp edged hardware. Replace, tighten and or sand smooth as required prior to playing.
- ✓ Verify that suspended climbing ropes, rope ladders, chain or cable are secured at both ends and cannot be looped back on itself as to create an entanglement hazard.
- ✓ On sunny and or hot days, check the slide and other plastic rides to assure that they are not very hot as to cause burns. Cool hot slide and rides with water and wipe dry prior to using.
- ✓ Orientate slide such that it gets the least amount of exposure to the sun.
- ✗ Do not allow children to wear open toe or heel footwear like sandals, flip-flops or clogs.
- ✗ Do not allow children to walk, in front, between, behind or close to moving rides.
- ✗ Do not let children twist swing chains or ropes or loop them over the top support bar. This may reduce the strength of the chain or rope and cause premature failure.
- ✗ Do not let children get off rides while they are in motion.
- ✗ Do not permit climbing on equipment when it is wet.
- ✗ Do not permit rough play or use of equipment in a manner for which it was not intended. Standing on or jumping from the roof, elevated platforms, swings, climbers, ladders or slide can be dangerous.
- ✗ Do not allow children to swing empty rides or seats.
- ✗ Do not allow children to go down slide head first or run up slide.

⚠️ Protective Surfacing - Reducing Risk of Serious Head Injury From Falls

One of the most important things you can do to reduce the likelihood of serious head injuries is to install shock-absorbing protective surfacing under and around your play equipment. The protective surfacing should be applied to a depth that is suitable for the equipment height in accordance with ASTM F1292. There are different types of surfacing to choose from; whichever product you select, follow these guidelines:

Loose-Fill Materials

- Maintain a minimum depth of 9 inches (23 cm) of loose-fill materials such as wood mulch/chips, engineered wood fiber (EWF), or shredded/recycled rubber mulch for equipment up to 8 feet (2,45 m) high; and 9 inches (23 cm) of sand or pea gravel for equipment up to 5 feet (1,5 m) high. NOTE: An initial fill level of 12 inches (31 cm) will compress to about a 9-inch (23 cm) depth of surfacing over time. The surfacing will also compact, displace, and settle, and should be periodically raked and refilled to maintain at least a 9-inch (23 cm) depth.
- Use a minimum of 6 inches (16 cm) of protective surfacing for play equipment less than 4 feet (1,22 m) in height. If maintained properly, this should be adequate. (At depths less than 6 inches (16 cm), the protective material is too easily displaced or compacted.)

NOTE: Do not install home playground equipment over concrete, asphalt, or any other hard surface. A fall onto a hard surface can result in serious injury to the equipment user. Grass and dirt are not considered protective surfacing because wear and environmental factors can reduce their shock absorbing effectiveness. Carpeting and thin mats are not adequate protective surfacing. Ground level equipment -- such as a sandbox, activity wall, playhouse or other equipment that has no elevated play surface -- does not need any protective surfacing.

- Use containment, such as digging out around the perimeter and/or lining the perimeter with landscape edging. Don't forget to account for water drainage.
- Periodically rake, check and maintain the depth of the loose-fill surfacing material. Marking the correct depth on the play equipment support posts will help you to see when the material has settled and needs to be raked and or replenished. Be sure to rake and evenly redistribute the surfacing in heavily used areas.
- Do not install loose fill surfacing over hard surfaces such as concrete or asphalt.

Poured-In-Place Surfaces or Pre-Manufactured Rubber Tiles

You may be interested in using surfacing other than loose-fill materials - like rubber tiles or poured-in-place surfaces.

- Installations of these surfaces generally require a professional and are not "do-it yourself" projects.
- Review surface specifications before purchasing this type of surfacing. Ask the installer/manufacturer for a report showing that the product has been tested to the following safety standard: ASTM F1292 *Standard Specification for Impact Attenuation of Surfacing Materials within the Use Zone of Playground Equipment*. This report should show the specific height for which the surface is intended to protect against serious head injury. This height should be equal to or greater than the fall height - vertical distance between a designated play surface (*elevated surface for standing, sitting, or climbing*) and the protective surfacing below - of your play equipment.
- Check the protective surfacing frequently for wear.

Placement

Proper placement and maintenance of protective surfacing is essential. Refer to diagram on front cover. Be sure to;

- Extend surfacing at least 6 feet (1,8 m) from the equipment in all directions.
- For to-fro swings, extend protective surfacing in front of and behind the swing to a distance equal to twice the height of the top bar from which the swing is suspended.
- For tire swings, extend surfacing in a circle whose radius is equal to the height of the suspending chain or rope, plus 6 feet (1,8 m) in all directions.

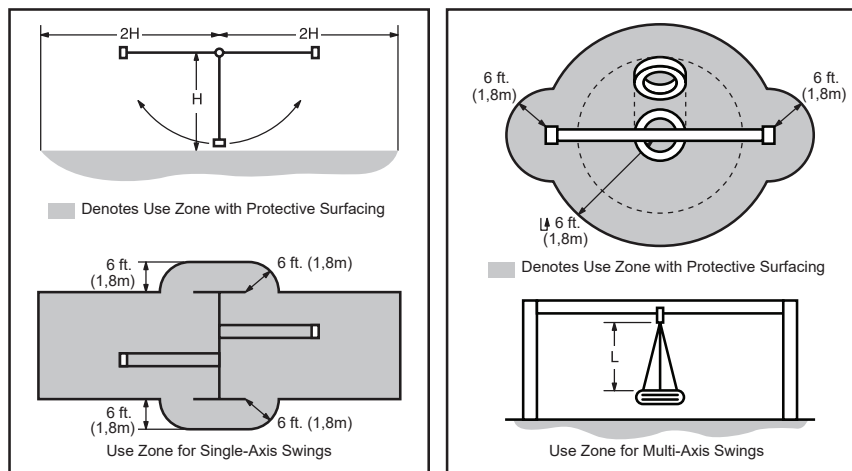

Instructions for Proper Maintenance

Your KidKraft Play System is designed and constructed of quality materials with your child's safety in mind. As with all outdoor products used by children, it will weather and wear. To maximize the enjoyment, safety and life of your Play Set, it is important that you, the owner, properly maintain it.

Check the following at the beginning of the play season:

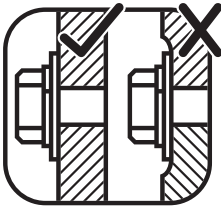
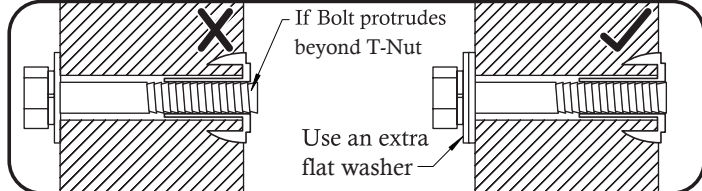
<p>HARDWARE:</p> <ul style="list-style-type: none"> ✓ Check metal parts for rust. If found, sand and repaint using a non-lead paint complying with 16 CFR 1303. ✓ Inspect and tighten all hardware. On wood assemblies DO NOT OVER-TIGHTEN as to cause crushing and splintering of wood. ✓ Check for sharp edges or protruding screw threads, add washers if required.   <p>SHOCK ABSORBING SURFACING:</p> <ul style="list-style-type: none"> ✓ Check for foreign objects. Rake and check depth of loose fill protective surfacing materials to prevent compaction and maintain appropriate depth. Replace as necessary. (See Protective Surfacing, page 3) 	<p>GROUND STAKES (ANCHORS):</p> <ul style="list-style-type: none"> ✓ Check for looseness, damage or deterioration. Should firmly anchor unit to ground during use. Re-secure and or replace, if necessary. <p>SWING HANGERS:</p> <ul style="list-style-type: none"> ✓ Check that bolts are secure and tight. Quick clips should be completely closed and threaded clips screwed tight. ✓ If squeaking occurs lubricate bushings with oil or WD-40®. <p>SWINGS, ROPES AND RIDES:</p> <ul style="list-style-type: none"> ✓ Reinstall if removed during cold season. Check all moving parts including swing seats, ropes, chains and attachments for wear, rust and other deterioration. Replace as needed. ✓ Check that ropes are tight, secure at both ends and cannot loop back as to create an entrapment. <p>WOOD PARTS:</p> <ul style="list-style-type: none"> ✓ Check all wood members for deterioration, structural damage and splintering. Sand down splinters and replace deteriorated wood members. As with all wood, some checking and small cracks in grain is normal. ✓ Applying a water repellent or stain (water-based) on a yearly basis is important maintenance to maintain maximum life and performance of the product.
----------------------------------------------------------------------------------------------------------------------------------------------------------------------------------------------------------------------------------------------------------------------------------------------------------------------------------------------------------------------------------------------------------------------------------------------------------------------------------------------------------------------------------------------------------------------------------------------------------------------------------------------------------------------------------------------------------------------------------------------------------------------------------------------------------------------------------------------------------------------------------------------------	-------------------------------------------------------------------------------------------------------------------------------------------------------------------------------------------------------------------------------------------------------------------------------------------------------------------------------------------------------------------------------------------------------------------------------------------------------------------------------------------------------------------------------------------------------------------------------------------------------------------------------------------------------------------------------------------------------------------------------------------------------------------------------------------------------------------------------------------------------------------------------------------------------------------------------------------------------------------------------------------------------------------------------------------------------------------------------------------------------------------------------------------------------------------------------------------------------------------------------------------------------------------------------------------------------------------------------------------------------------

Check twice a month during play season:

<p>HARDWARE:</p> <ul style="list-style-type: none"> ✓ Inspect for tightness. Must be firmly against, but not crushing the wood. DO NOT OVER-TIGHTEN. This will cause splintering of wood. ✓ Check for sharp edges or protruding screw threads. Add washers if required. 	<p>SHOCK ABSORBING SURFACING:</p> <ul style="list-style-type: none"> ✓ Rake and check depth of loose fill protective surfacing materials to prevent compaction and maintain appropriate depth. Replace as necessary. (See Protective Surfacing, page 3)
---------------------------------------------------------------------------------------------------------------------------------------------------------------------------------------------------------------------------------------------------------------------------------------------------------------	-------------------------------------------------------------------------------------------------------------------------------------------------------------------------------------------------------------------------------------------------------------------------------

Check once a month during play season:

<p>SWING HANGERS:</p> <ul style="list-style-type: none"> ✓ Check that they are secure and orientated correctly. Hook should rotate freely and perpendicular to support beam. ✓ If squeaking occurs lubricate bushings with oil or WD-40®. 	<p>SWINGS AND RIDES:</p> <ul style="list-style-type: none"> ✓ Check swing seats, all ropes, chains and attachments for fraying, wear, excessive corrosion or damage. Replace if structurally damaged or deteriorated.
--------------------------------------------------------------------------------------------------------------------------------------------------------------------------------------------------------------------------------------------------------------------------	---------------------------------------------------------------------------------------------------------------------------------------------------------------------------------------------------------------------------------------------

Check at the end of the play season:

<p>SWINGS AND RIDES:</p> <ul style="list-style-type: none"> ✓ To prolong their life, remove swings and store inside when outside temperature is below 32°F/0°C. Below freezing, plastic parts may become more brittle. 	<p>SHOCK ABSORBING SURFACING:</p> <ul style="list-style-type: none"> ✓ Rake and check depth of loose fill protective surfacing materials to prevent compaction and maintain appropriate depth. Replace as necessary. (See Protective Surfacing, page 3)
----------------------------------------------------------------------------------------------------------------------------------------------------------------------------------------------------------------------------------------------	-------------------------------------------------------------------------------------------------------------------------------------------------------------------------------------------------------------------------------------------------------------------------------

If you dispose of your play set: Please disassemble and dispose of your unit so that it does not create any unreasonable hazards at the time it is discarded. Be sure to follow your local waste ordinances.

About Our Wood

KidKraft Premium Play Systems uses only premium playset lumber, ensuring the safest product for your children's use. Although we take great care in selecting the best quality lumber available, wood is still a product of nature and susceptible to weathering which can change the appearance of your set.

What causes weathering? Does it affect the strength of my Play System?

One of the main reasons for weathering is the effects of water (moisture); the moisture content of the wood at the surface is different than the interior of the wood. As the climate changes, moisture moves in or out of the wood, causing tension which can result in checking and or warping. You can expect the following due to weathering. These changes will not affect the strength of the product:

1. **Checking** is surface cracks in the wood along the grain. A post (4" x 4") will experience more checking than a board (1" x 4") because the surface and interior moisture content will vary more widely than in thinner wood.
2. **Warping** results from any distortion (twisting, cupping) from the original plane of the board and often happens from rapid wetting and drying of the wood.
3. **Fading** happens as a natural change in the wood color as it is exposed to sun-light and will turn a grey over time.

How can I reduce the amount of weathering to my Play System?

At the factory we have coated the wood with a water repellent or stain. This coating decreases the amount of water absorption during rain or snow thus decreasing the tension in the wood. Sunlight will break down the coating, so we recommend applying a water repellent or stain on a yearly basis (see your local stain and paint supplier for a recommended product).

Most weathering is just the normal result of nature and will not affect safe play and enjoyment for your child. However if you are concerned that a part has experienced a severe weathering problem please call our consumer relations department for further assistance.

Complete and mail registration card to receive important product notifications and assure prompt warranty service.

KidKraft Limited Warranty

MISSING OR DAMAGED PARTS:

KidKraft will replace any parts within 90 days from date of purchase found to be missing from or damaged in the original packaging. See Fig.1

Fig. 1	<u>Product Age (All Parts)</u> 0-90 Days from date of purchase	<u>Consumer Pays</u> \$0 for Part + Free Shipping
--------	-------------------------------------------------------------------	------------------------------------------------------

DEFECTS IN MATERIAL AND WORKMANSHIP:

KidKraft warrants that this product is free from defects in materials and workmanship for a period of one (1) year from the original date of purchase (dated sales receipt and/or product registration is required). This one (1) year warranty covers all parts including wood, hardware, and all accessories (Such as swings, rides, and slides). See Fig. 2

Fig. 2	<u>Product Age (All Parts)</u> 91 Days to 1 Year	<u>Consumer Pays</u> \$0 for Part + Free Shipping
--------	-----------------------------------------------------	------------------------------------------------------

WOOD ROT, DECAY, AND INSECT DAMAGE:

All wood carries a five (5) year warranty against rot, decay, and insect damage (dated sales receipt and/or product registration is required). Refer to the schedule below for charges associated with replacement of wood parts under this **Limited Warranty**. See Fig. 3

Fig. 3	<u>Product Age (Wood Parts)</u> 0 Days to 1 Year After 1 Year to 5 Year Over 5 Years	<u>Consumer Pays</u> \$0 for Part + Free Shipping \$0 for Part + Shipping & Handling 100% for Part (if available) + Shipping & Handling
--------	-----------------------------------------------------------------------------------------------	--------------------------------------------------------------------------------------------------------------------------------------------------

This warranty applies to the original owner and registrant and is non-transferable. Regular maintenance is required to ensure the integrity of this product. Failure by the owner to maintain the product according to the maintenance requirements may void this warranty.

This Limited Warranty does NOT cover:

- Any inspection cost
- Labor and/or costs for replacement of any defective item(s), including but not limited to, professional installer costs
- Incidental or consequential damages, including but not limited to, as a result of set relocation, move and/or reinstall
- Cosmetic defects which do not affect performance or integrity of a part or the entire product
- Vandalism, improper use or installation, or acts of nature, including but not limited to, high winds, fire, and flood
- Minor twisting, warping, checking, or any natural occurring properties of wood that do not affect performance or integrity.
- Any KidKraft product purchased, including but not limited to, a non-approved retailer, auction houses, second-hand, and as-is clearance items.

KidKraft products have been designed for safety and quality. Modifications made to the original product may damage the structural integrity of the unit leading to failure and possible injury. KidKraft cannot assume any responsibility for the modified products. Furthermore, modifications void all warranties.

This product is warranted for **RESIDENTIAL USE ONLY**. Under no circumstance should a KidKraft product be used in public settings such as schools, churches, playgrounds, parks, home and professional day cares and the like. Such use may lead to product failure and potential injury. Public use will void this warranty. KidKraft disclaims all other representations and warranties of any kind, express or implied.

Keys to Assembly Success

Tools Required

<ul style="list-style-type: none"> • Tape Measure • Carpenters Level • Carpenters Square • Claw Hammer • Standard or Cordless Drill • Rubber Mallet 	<ul style="list-style-type: none"> • #1 Phillips, #2 Robertson and Screwdriver • Ratchet with extension (1/2" & 9/16" sockets) 	<ul style="list-style-type: none"> • Open End Wrench (1/2" & 9/16") • Adjustable Wrench • 1/8" & 3/16" Drill Bits 	<ul style="list-style-type: none"> • 3/16" Hex Key • 8' Step Ladder • Safety Glasses • Adult Helpers • Pencil
-----------------------------------------------------------------------------------------------------------------------------------------------------------------------------------------------------------------	------------------------------------------------------------------------------------------------------------------------------------------------------------	------------------------------------------------------------------------------------------------------------------------------------------------------------	------------------------------------------------------------------------------------------------------------------------------------------------------------------

Part Identification Key





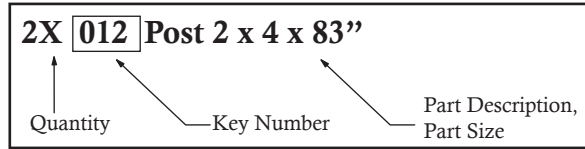

On each page, you will find the parts and quantities required to complete the assembly step illustrated on that page.

Here is a sample.



Symbols

Throughout these instructions symbols are provided as important reminders for proper and safe assembly.

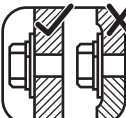
<p>This identifies information that requires special attention. Improper assembly could lead to an unsafe or dangerous condition.</p> 	<p>Check that set or assembly is properly level before proceeding.</p> <p>Use Level</p> 
<p>Use Help</p>  <p>Use Help</p>  <p>Where this is shown, 2 or 3 people are required to safely complete the step. To avoid injury or damage to the assembly make sure to get help!</p>	<p>Pre-drill 1/8" & 3/16" Bit</p> <p>Pre-drill a pilot hole before fastening screw or lag to prevent splitting of wood.</p>
<p>Measure Distance</p>  <p>Check that assembly is square before tightening bolts.</p> <p>Square Assembly</p> 	<p>Tighten Bolts</p>  <p>This indicates time to tighten bolts, but not too tight! Do not crush the wood. This may create splinters and cause structural damage.</p>

CAUTION – Protrusion Hazard

Once the assembly is tightened, watch for exposed threads. If a thread protrudes from the T-Nut, remove the bolt and add washers to eliminate this condition. Extra washers have been provided for this purpose.

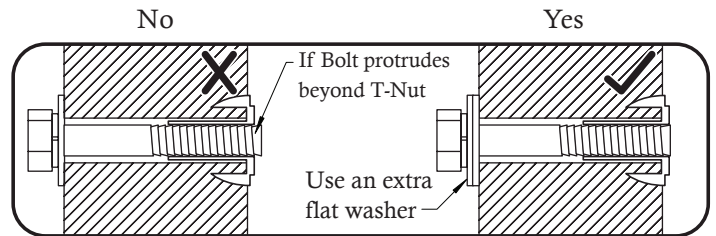

Proper Hardware Assembly

Lag screws require drilling pilot holes to avoid splitting wood. Only a flat washer is required. For ease of installation liquid soap can be used on all lag-type screws.

For bolts, tap T-Nut into hole with hammer. Insert the hex bolt through lock washer first then flat washer then hole. Because the assemblies need to be squared do not completely tighten until instructed. Pay close attention to diameter of the bolts. 5/16" is slightly larger than 1/4".

Note: Wafer head bolts with blue lock tight or a bolt with a Ny-Lok nut do NOT require a lock washer.

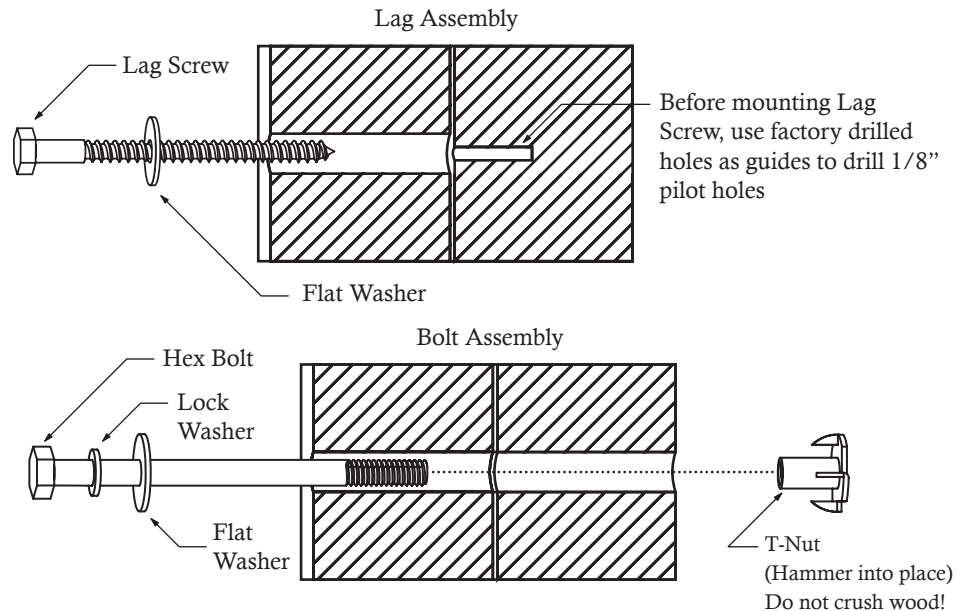

Part Identification (Reduced Part Size)

4pc. - [9460] - 31.8 x 63.5 x 1355.8 - Floor Joist - Box 1 - 3569460



1-1/4 x 2-1/2 x 53-3/8"

4pc. - [9461] - 31.8 x 63.5 x 796.9 - Floor Joist Short - Box 1 - 3569461



1-1/4 x 2-1/2 x 31-3/8"

2pc. - [9462] - 38.1 x 38.1 x 1355.8 - Side Joist - Box 1 - 3569462



1-1/2 x 1-1/2 x 53-3/8"

11pc. - [9463] - 15.9 x 133.4 x 863.8 - Floor Board - Box 2 - 3589463



5/8 x 4-1/2 x 34"

1pc. - [9518] - 15.9 x 88.9 x 863.8 - Floor Board B - Box 2 - 3589518

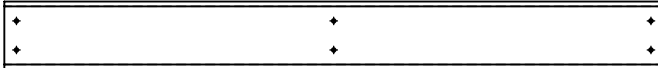

5/8 x 3-1/2 x 34"

1pc. - [9464] - 31.8 x 76.2 x 1362.2 - Floor Support A - Box 1 - 3569464



1-1/4 x 3 x 53-5/8"

1pc. - [9465] - 38.1 x 38.1 x 1292.4 - Side Joist 1 - Box 1 - 3569465



1-1/2 x 1-1/2 x 50-7/8"

1pc. - [9466] - 38.1 x 38.1 x 1419.3 - Side Joist 2 - Box 1 - 3569466



1-1/2 x 1-1/2 x 55-7/8"

11pc. - [9467] - 15.9 x 114.3 x 498.2 - Floor Board Short - Box 2 - 3589467

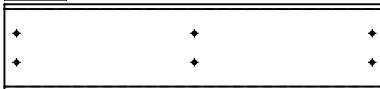

5/8 x 4-1/2 x 19-39/64"

2pc. - [9468] - 15.9 x 82.6 x 498.2 - Floor Board Short 1 - Box 1 - 3589468

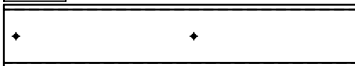

5/8 x 3-1/4 x 19-39/64"

1pc. - [9469] - 31.8 x 76.2 x 1425.7 - Floor Support - Box 1 - 3569469



1-1/4 x 3 x 56-1/8"

2pc. - [9470] - 25.4 x 50.8 x 317.6 - Counter Brace - Box 1 - 3589470



1 x 2 x 12-1/2"

4pc. - [9471] - 25.4 x 50.8 x 209.5 - Counter Joist - Box 1 - 3589471

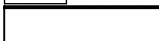

1 x 2 x 8-1/4"

1pc. - [9472] - 15.9 x 69.9 x 817.6 - Counter Front - Box 1 - 3589472



5/8 x 2-3/4 x 32-3/16"

1pc. - [9473] - 15.9 x 82.6 x 817.6 - Counter Back - Box 1 - 3589467



5/8 x 3-1/4 x 32-3/16"

1pc. - [9474] - 15.9 x 31.8 x 817.6 - Counter Top - Box 1 - 3589474

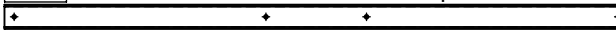

5/8 x 1-1/4 x 32-3/16"

2pc. - [9475] - 15.9 x 85.7 x 212.7 - Counter Mid Top - Box 2 - 3589475



5/8 x 3-3/8 x 8-3/8"

2pc. - [9476] - 15.9 x 50.8 x 175.7 - Counter Side - Box 2 - 3589467



5/8 x 2 x 6-59/64"

1pc. - [9477] - 31.8 x 63.5 x 609.1 - Supporting Diagonal - Box 1 - 3569477

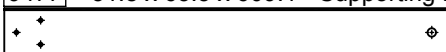

1-1/4 x 2-1/2 x 23-63/64"

Part Identification (Reduced Part Size)

1pc. - [9478] - 34.9 x 69.9 x 1309.1 - Left Rail - Box 2 - 3589478



1pc. - [9479] - 34.9 x 69.9 x 1309.1 - Right Rail - Box 2 - 3589479



4pc. - [9480] - 25.4 x 82.6 x 492 - Ladder Gap - Box 2 - 3589480



1pc. - [9481] - 15.9 x 82.6 x 532 - RW-AL Suport - Box 1 - 3589481



1pc. - [9482] - 15.9 x 82.6 x 532 - RW-AL Suport A - Box 1 - 3589482

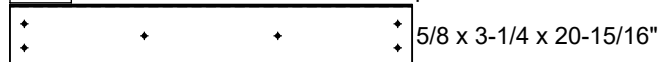

1pc. - [9483] - 31.8 x 63.5 x 578.1 - Diagonal - Box 1 - 3569483

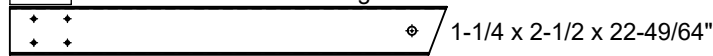

2pc. - [9484] - 31.8 x 63.5 x 1288 - Rail - Box 2 - 3589484

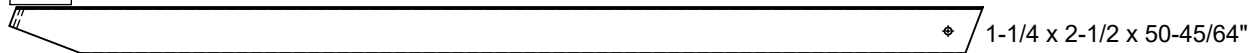

7pc. - [9485] - 15.9 x 114.3 x 500 - Board Rock - Box 2 - 3589485

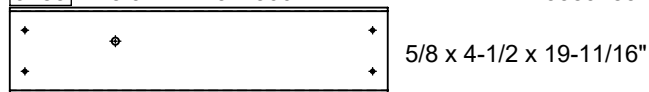

1pc. - [9522] - 15.9 x 114.3 x 500 - Board Rock - Box 2 - 3589522



2pc. - [9486] - 25.4 x 38.1 x 211.1 - Chair Gusset - Box 2 - 3589486

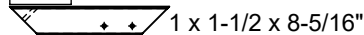

2pc. - [9487] - 25.4 x 38.1 x 146.1 - Chair Gusset A - Box 2 - 3589487

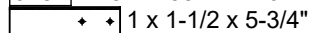

1pc. - [9488] - 25.4 x 79.4 x 471.4 - Chair Top - Box 2 - 3589488

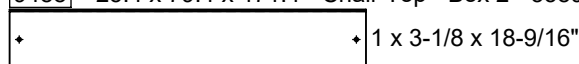

1pc. - [9489] - 25.4 x 79.4 x 471.4 - Chair Top A - Box 2 - 3589489

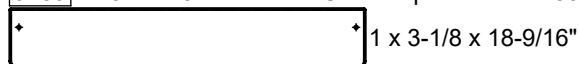

1pc. - [9490] - 31.8 x 63.5 x 598.5 - Ground Brace - Box 1 - 3569490



1pc. - [9491] - 25.4 x 63.5 x 534.9 - Ground Brace A - Box 1 - 3569491

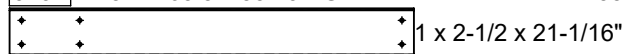

1pc. - [9492] - 31.8 x 63.5 x 698.5 - Ground Brace B - Box 1 - 3569492

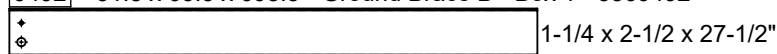

1pc. - [9493] - 31.8 x 76.2 x 495.3 - Ground Brace C - Box 1 - 3569493



2pc. - [9494] - 31.8 x 63.5 x 2286 - Crowsnest Upright - Box 2 - 3569494

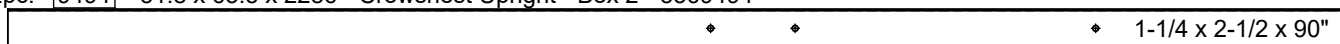

2pc. - [9495] - 25.4 x 50.8 x 304.8 - Crowsnest Gusset - Box 1 - 3569495

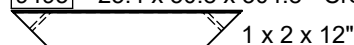

Part Identification (Reduced Part Size)

1pc. - **9497** - 31.8 x 63.5 x 534.9 - Crowsnest Short A - Box 1 - 3569497



1pc. - **9498** - 31.8 x 63.5 x 566.7 - Crowsnest Short L - Box 1 - 3569498



1pc. - **9499** - 31.8 x 63.5 x 1457.3 - Crowsnest Bottom - Box 2 - 3569499



2pc. - **9499A** - 31.8 x 63.5 x 1457.3 - Crowsnest Bottom - Box 2 - 3589499



12pc. - **9500** - 19.1 x 63.5 x 558.8 - Cedar Wall - Box 2 - 3589500



2pc. - **9501** - 31.8 x 50.8 x 1433.4 - Top Swing - Box 2 - 3569501



2pc. - **9502** - 31.8 x 50.8 x 269.3 - Roof Support Upright - Box 1 - 3569502

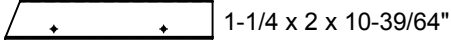

2pc. - **9503** - 31.8 x 50.8 x 865.2 - Roof Support - Box 2 - 3569503



1pc. - **9504** - 31.8 x 50.8 x 1136.7 - Roof Sleeper Left - Box 2 - 3569504

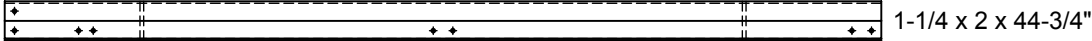

1pc. - **9519** - 31.8 x 50.8 x 1136.7 - Roof Sleeper Right - Box 2 - 3569519

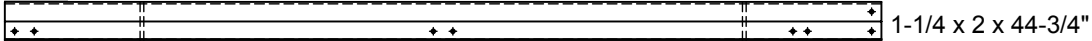

1pc. - **9506** - 31.8 x 50.8 x 1374.8 - Roof Bottom A - Box 1 - 3569506



1pc. - **9507** - 31.8 x 50.8 x 670.4 - Roof Sleeper Short L - Box 1 - 3569507



1pc. - **9508** - 31.8 x 50.8 x 670.4 - Roof Sleeper Short - Box 1 - 3569508

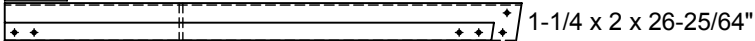

1pc. - **9509** - 31.8 x 50.8 x 1374.8 - Roof Bottom B - Box 2 - 3569509



5pc. - **9511** - 25.4 x 50.8 x 1362.1 - Roof Bottom - Box 1 - 3569511



1pc. - **9512** - 15.9 x 50.8 x 1425.6 - Roof Cover - Box 2 - 3569512

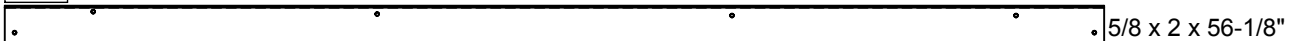

1pc. - **9520** - 15.9 x 133.4 x 1425.6 - Roof Cover - Box 1 - 3569520



1pc. - **9513** - 25.4 x 63.5 x 254 - Door Stop - Box 1 - 3569513



1pc. - **9514** - 31.8 x 88.9 x 617.1 - Mid Cross - Box 2 - 3569514



2pc. - **9496** - 31.8 x 63.5 x 534.9 - Crowsnest Short - Box 2 - 3569496



Part Identification (Reduced Part Size)

3pc. - **[9515]** - 25.4 x 63.5 x 866.8 - Table Top - Box 2 - 3589515

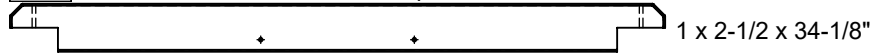

2pc. - **[9516]** - 25.4 x 63.5 x 433.4 - Table Top Short - Box 1 - 3589516

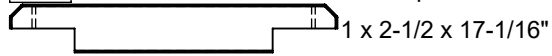

1pc. - **[9521]** - 34.9 x 76.2 x 358.1 - Gusset - Box 2 - 3569521



1pc. - **[9262]** - Door

31.8 x 400.1 x 491.8mm
1-1/4 x 15-3/4 x 19-23/64 \"

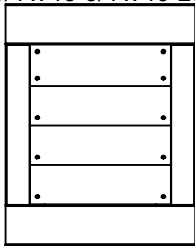

Box 1 - 37589262

1pc. - **[9261]** - Window Panel

31.8 x 374.9 x 1362.1mm
1-1/4 x 14-49/64 x 53-5/8\"

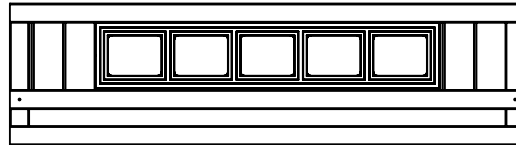

Box 1 - 37569261

Part Identification (Reduced Part Size)

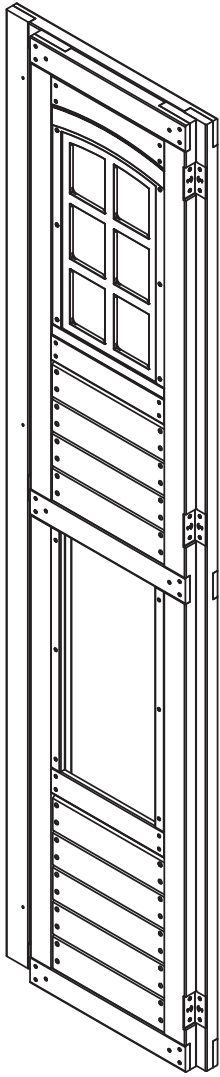

1pc. - **9263** - 63.5 x 558.8 x 2286mm
 2-1/2 x 22 x 90"
 Folding Panel Assembly Right A -
 37569263

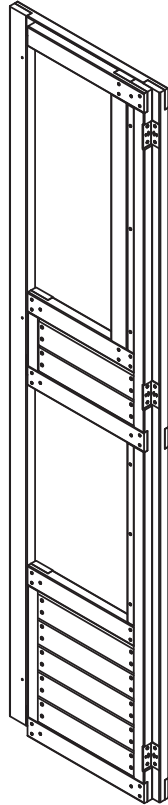

1pc. - **9264** - 63.5 x 558.8 x 2286mm
 2-1/2 x 22 x 90"
 Folding Panel Assembly Left A -
 37569264

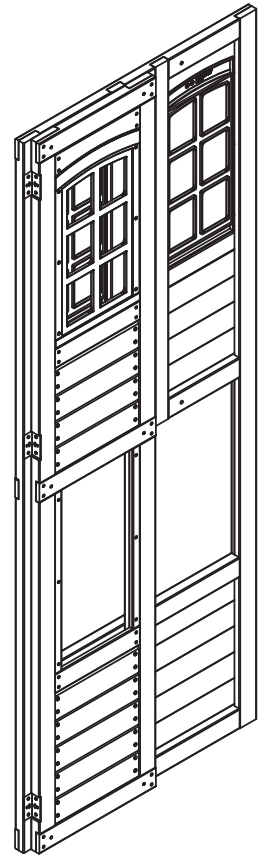

1pc. - **9265** - 63.5 x 866.6 x 2286mm
 2-1/2 x 34-1/4 x 90"
 Folding Panel Assembly Left B -
 37569265

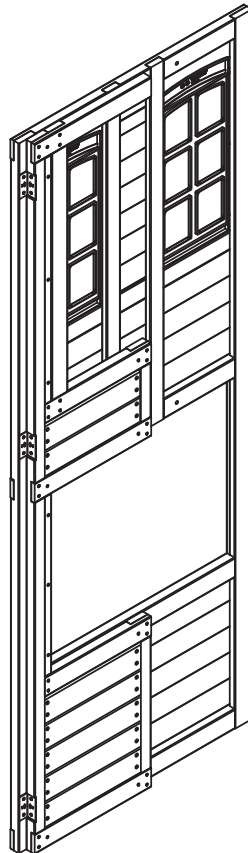

1pc. - **9266** - 63.5 x 866.6 x 2286mm
 2-1/2 x 34-1/4 x 90"
 Folding Panel Assembly Right B -
 37569266

Hardware Identification (Actual Size)

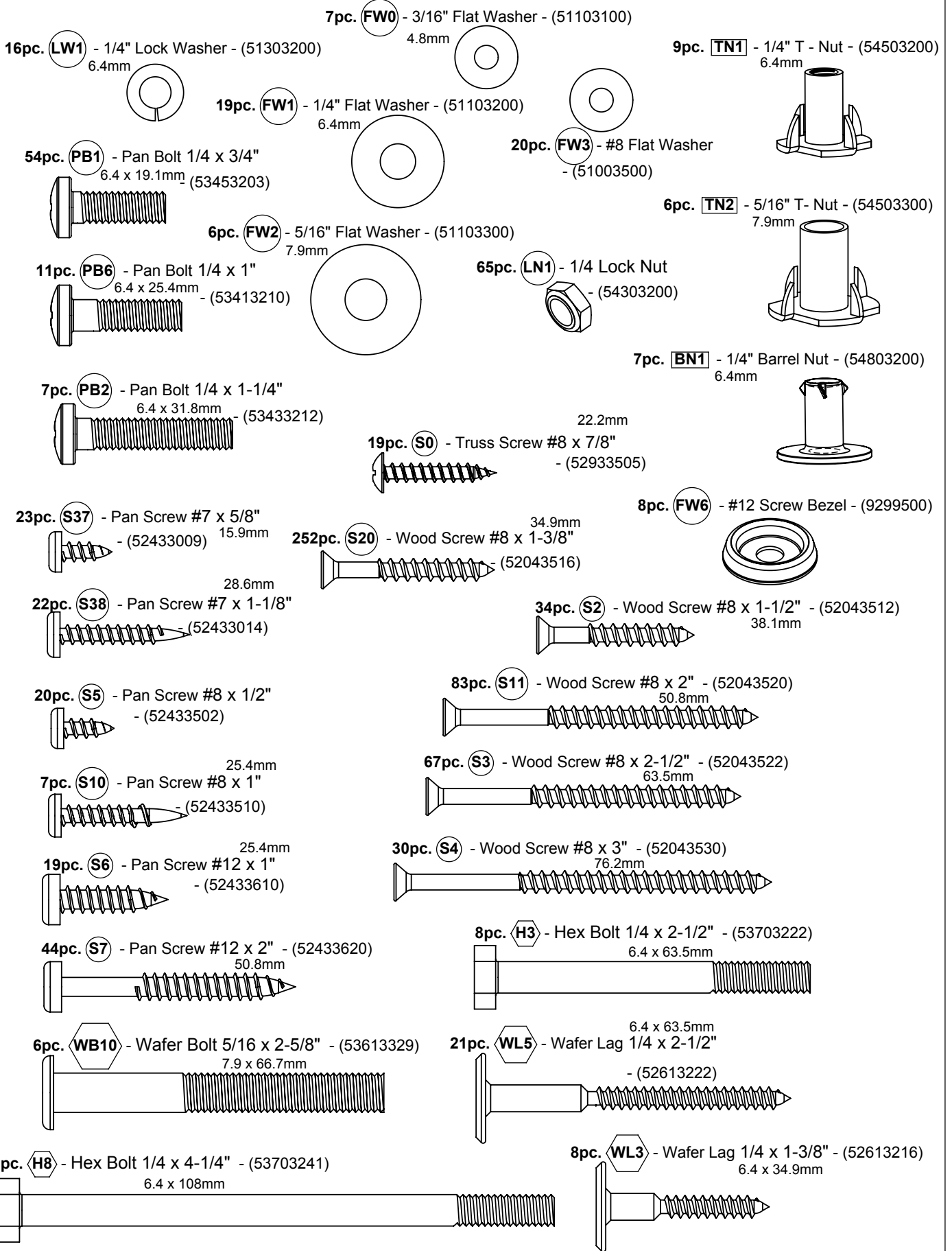

Part Identification (Reduced Part Size)

1x - Quadrex Driver (9200015)
1x - Cozy Escape Playhouse Rocks (7 Pk) (3329045) Green/Peacock
1x - 1/8" Drill Bit (9300183)
1x - TNR3 Extend Flange Rt (3310131) (Green)
1x - Rebar Ground Stake (6 Pk) (3200318)
1x - Door Bumper (9331632)
1x - Factory Mount Door Hinge (2 Pk) (3200147)
1x - #2 x 2" Robertson Driver (9200014)
1x - TNR 3 Tube Support (9201601)
4x - Steel Hand Grip (9202111) (Peacock)
1x - Kidkraft 3L Plaque (9320374)
1x - TNR4 Post Mount Kit (3201655)
2x - TNR 4 Post Mount Clamp (9201657)
31x - Square Nylok Nut (54902200)
3x - Flat Panel Brkt (9201633)
30x - 1/4 x 12.7mm Pan Head Bolt (53453202)
1x - TNR 4 Post Mount Base (9201656)
1x - 1/4 x 14.5mm Pan Head Bolt (53452209)
1x - Cozy Escape Bracket Set (3209045)
2x - Flower Box Set (3320401) (Green)
1x - Special Weather Caps (3322857) (22 Pk of 9332857)
10x - TNR 4 Clamp Ring (9300130) (Green) 10pcs number 3300130
1x - Utensils Shelf (9320791)
1x - Pot Pan Spatula (9320889)
1x - Sink Set (3330908)
1x - Stove (3320738)
10x - #6 x 10mm Blunt Point Pan Screw (52402902)
1x - Faucet (9320881)
1x - Sink Knob (9320482)
1x - Sink Knob (9320382)
1x - Sink (9330908)
8x - Mount Clips (9320088)
1x - Cozy Escape Triangle Canopy Set (3759045) (Green/Yellow)
1x - Magnetic Catch Kit (3201730)
1x (9207713) Door Catch
1x Magnetic Catch
1x Catch Plate
2x (9207711) Door Handle
1x - TNR2 Slide Elbow (3310121) (Green)
1x - TNR2 Slide Exit Top (3310124) (Green)
1x - TNR3 Short Exit (3310132) (Green)
1x - Deluxe Kitchen Set - (3320969)
1x - Cozy Escape Wave ASA Roof Panel Set (Dark Grey) (3332845)

Cozy Escape Wave ASA Roof Panel Set
1x - 1124mmX1067mm PVC Roof Panel (9332853)
1x - 370mmX1067mm PVC Roof Panel (9332854)
1x - 1124mmX650mm PVC Roof Panel (9332855)
1x - 370mmX650mm PVC Roof Panel (9332856)

Step 1: Inventory Parts - Read This Before Starting Assembly

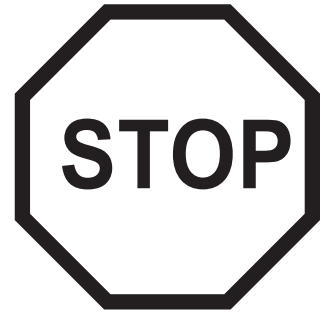
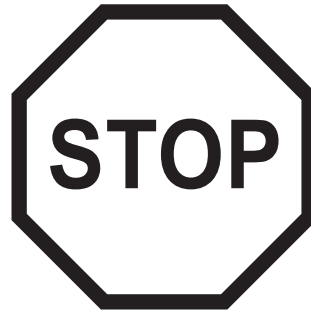
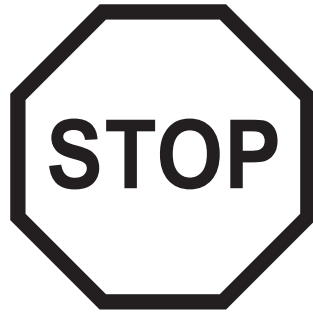
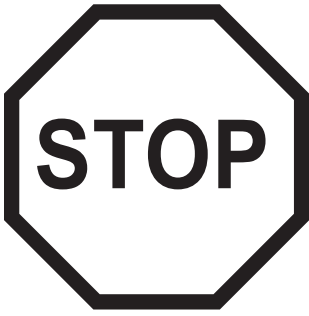

A. This is the time for you to inventory all your hardware, wood and accessories, referencing the parts identification sheets. This will assist you with your assembly.

- The wood pieces will have the key number stamped on the ends of the boards. Organize the wood pieces by step, as per the key numbering system below.

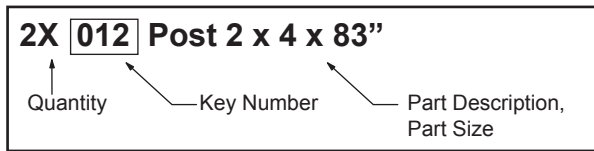

- Please refer to Page 7 for proper hardware assembly.
- Each step indicates which bolts and/or screws you will need for assembly, as well as any flat washers, lock washers, t-nuts or lock nuts.

B. If there are any missing or damaged pieces or you need assistance with assembly please contact the consumer relations department directly. Call us before going back to the store.

1.800.933.0771 or 972.385.0100
customerservice@kidkraft.com
canadacustomerservice@kidkraft.com
For online parts replacement visit
<https://parts.kidkraft.com/>

+31 20 305 8620
europcustomerservice@KidKraft.com
For online parts replacement visit
<https://parts.kidkraft.eu/>

C. Read the assembly manual completely, paying special attention to ANSI warnings; notes; and safety/maintenance information on pages 1 - 7.

D. Before you discard your cartons fill out the form below.

- The carton I.D. stamp is located on the end of each carton. The tracking number is located on the KidKraft ID Plaque (9320374).
- Please retain this information for future reference. You will need this information if you contact the Consumer Relations Department.

MODEL NUMBER: **F29045**

CARTON I.D. STAMP: __ __ __ __ 14459 __ (Box 1)

CARTON I.D. STAMP: __ __ __ __ 14459 __ (Box 4)

CARTON I.D. STAMP: __ __ __ __ 14459 __ (Box 2)

CARTON I.D. STAMP: __ __ __ __ 14459 __ (Box 5)

CARTON I.D. STAMP: __ __ __ __ 14459 __ (Box 3)

CARTON I.D. STAMP: __ __ __ __ 14459 __ (Box 6)

TRACKING NUMBER (from ID Plaque): _____

Step 2: Frame Assembly Part 1

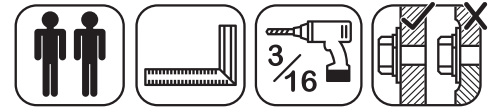

A: With a helper, stand the (9263) Folding Panel Assembly Right A in the upright position and unfold, checking to make sure the panel assembly is square. Pre-drill using a 3/16" drill bit, then install 5 (WL5) 1/4 x 2- 1/2" Wafer Lags to secure the panel. (fig 2.1)

B: Repeat step A to secure the (9265) Folding Panel Assembly Left B. (fig 2.1)

Fig. 2.1

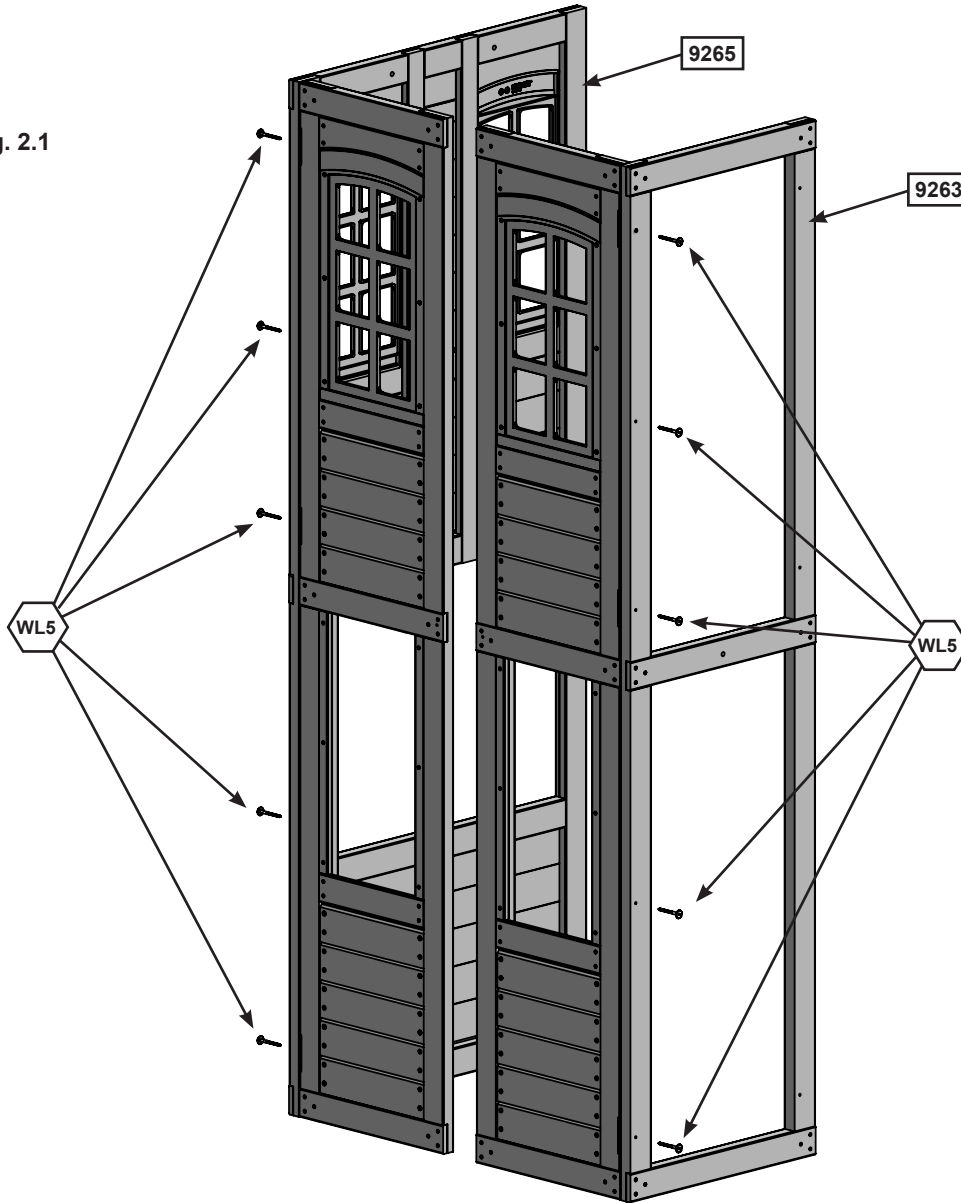

Wood Parts

- 1 x 9263 Folding Panel Assembly Right A 2-1/2 x 22 x 90"
- 1 x 9265 Folding Panel Assembly Left B 2-1/2 x 34-1/4 x 90"

Hardware

- 10 x WL5 1/4 x 2-1/2" Wafer Lag

Step 2: Frame Assembly Part 2

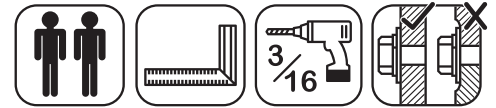

C: With a helper, stand the (9264) Folding Panel Assembly Left A in the upright position and unfold, checking to make sure the panel assembly is square. Pre-drill using a 3/16" drill bit, then install 5 (WL5) 1/4 x 2- 1/2" Wafer Lags to secure the panel. (fig 2.2)

D: Repeat step C to secure the (9266) Folding Panel Assembly Right B. (fig 2.2)

Fig. 2.2

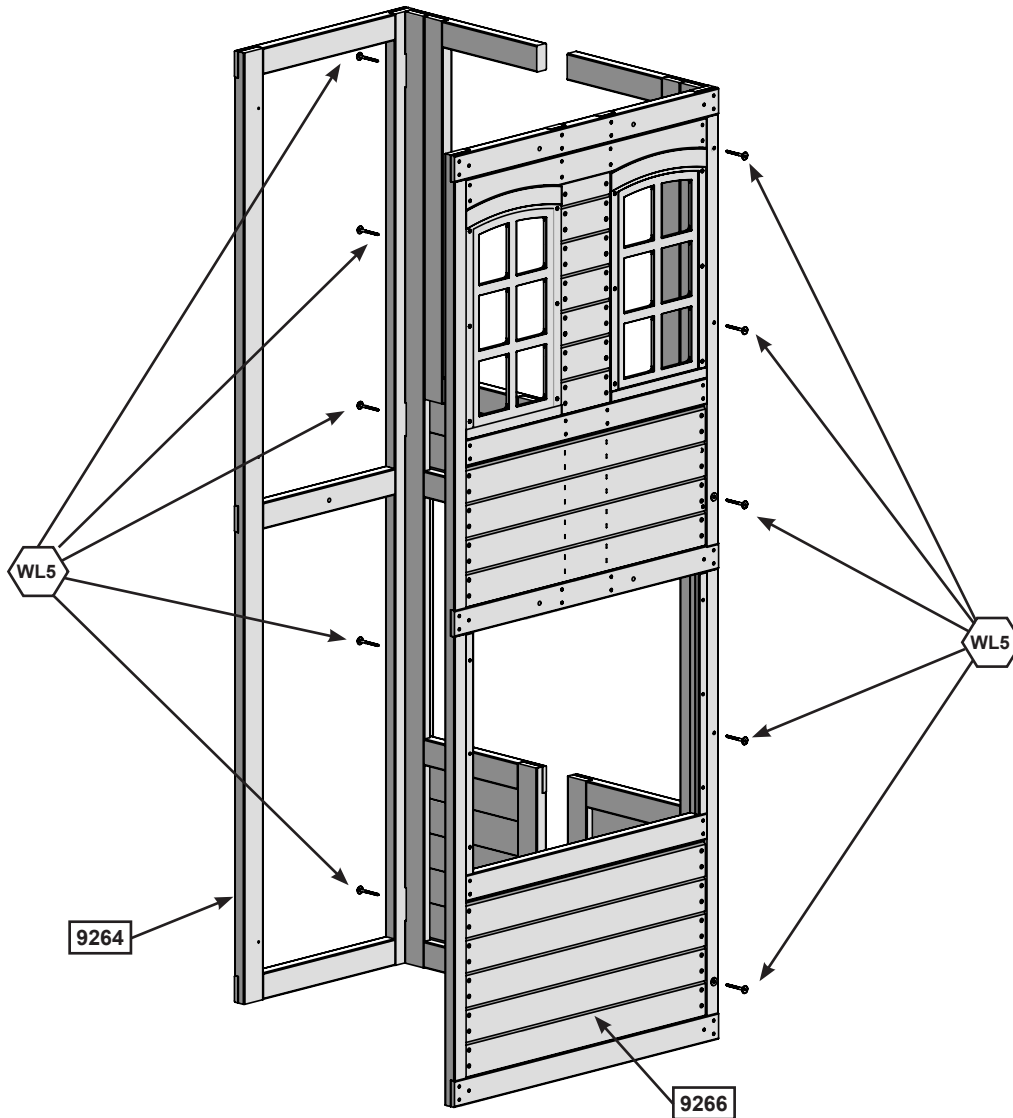

Wood Parts

- 1 x 9264 Folding Panel Assembly Left A 2-1/2 x 22 x 90"
- 1 x 9266 Folding Panel Assembly Right B 2-1/2 x 34-1/4 x 90"

Hardware

- 10 x WL5 1/4 x 2-1/2" Wafer Lag

Step 3: Join Frame Assemblies Part 1

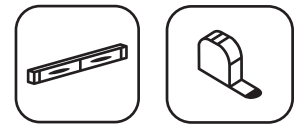

A: From inside the assembly, halfway up and tight to both end walls, place 1 (9462) Side Joist against (9265) Folding Panel Assembly Left B and (9264) Folding Panel Assembly Left A, making sure that it's 5/8" below the panel opening. Loosely attach (9462) Side Joist with 3 (WB10) 5/16 x 2-5/8" Wafer Bolts (with flat washer and t-nut). Bolts are installed from inside the assembly. Make sure (9462) Side Joist is level then attach with 2 (S3) #8 x 2-1/2" Wood Screws and tighten bolts. (fig. 3.1 & 3.2 & 3.3)

B: Repeat Step A to attach 1 (9462) Side Joist to (9263) Folding Panel Assembly Right A and (9266) Folding Panel Assembly Right B. (fig. 3.1 & 3.2 & 3.3)

Fig. 3.1
Top View

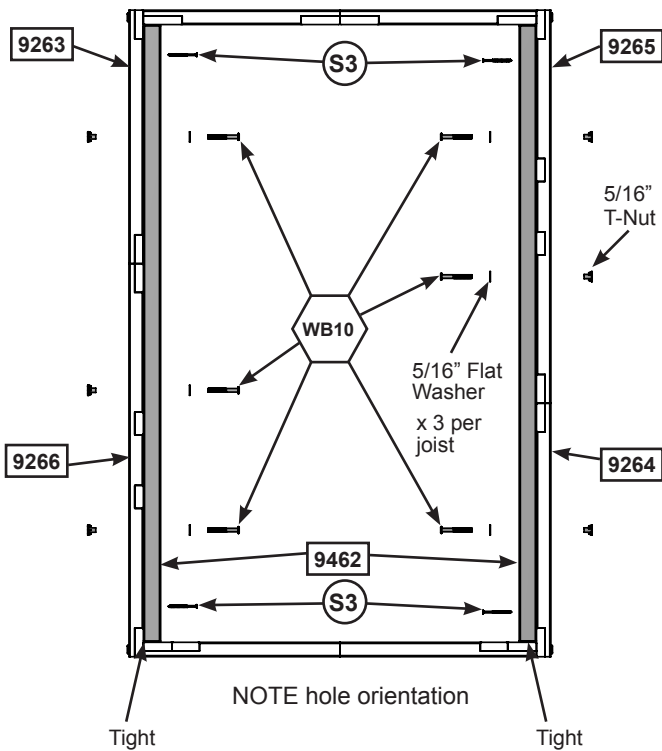

Fig. 3.2

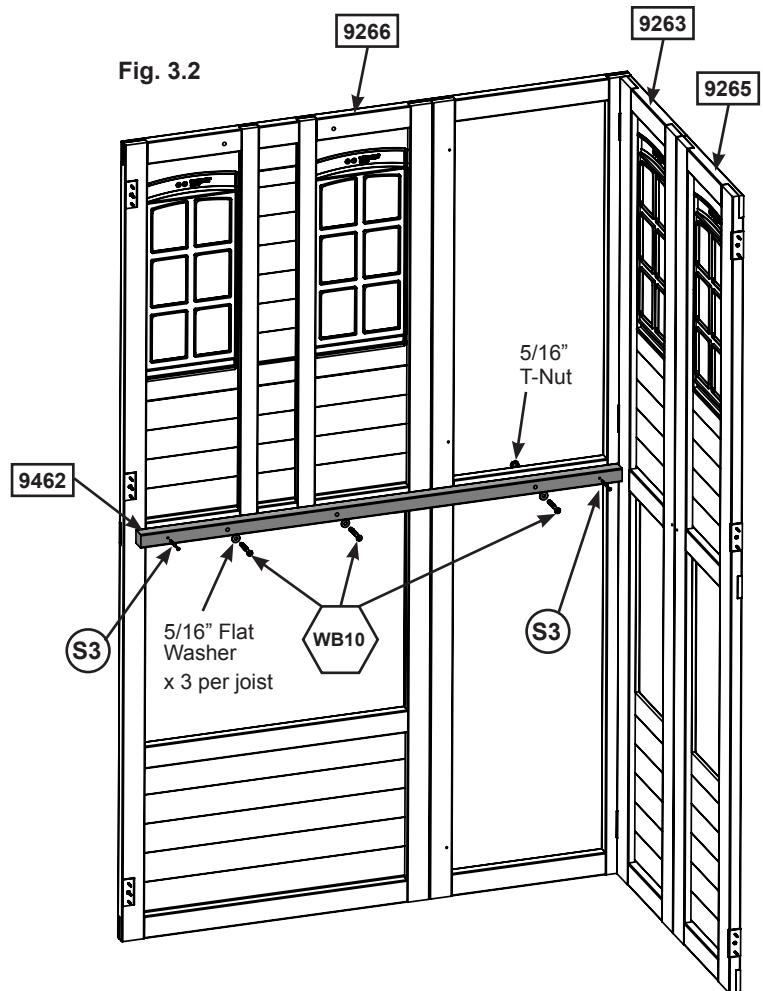
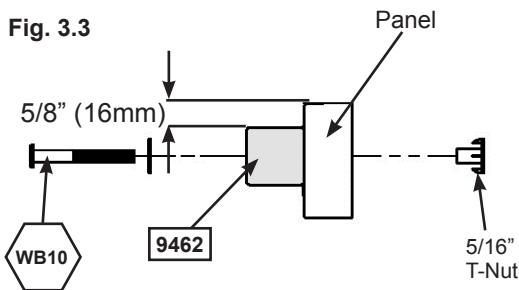

Fig. 3.3



Wood Parts

2 x 9462 Side Joist 1-1/2 x 1-1/2 x 53-3/8"

Hardware

4 x S3 #8 x 2-1/2" Wood Screw

6 x WB10 5/16 x 2-5/8" Wafer Bolt
(5/16" flat washer, 5/16" t-nut)

Step 3: Join Frame Assemblies Part 2



C: Place 1 (9460) Floor Joist along the bottom of the front and back walls so they are flush to the bottom. Check to make sure that the joists are level then attach each joist using 5 (S7) #12 x 2" Pan Screws. (fig.3.4, 3.5 and 3.7)

D: Place 1 (9461) Floor Joist Short along each end wall, between the (9460) Floor Joists. Check to make sure they are level and flush to the bottom, then attach using 4 (S7) #12 x 2" Pan Screws per side. (fig. 3.4, 3.6 and 3.8)

Fig. 3.4

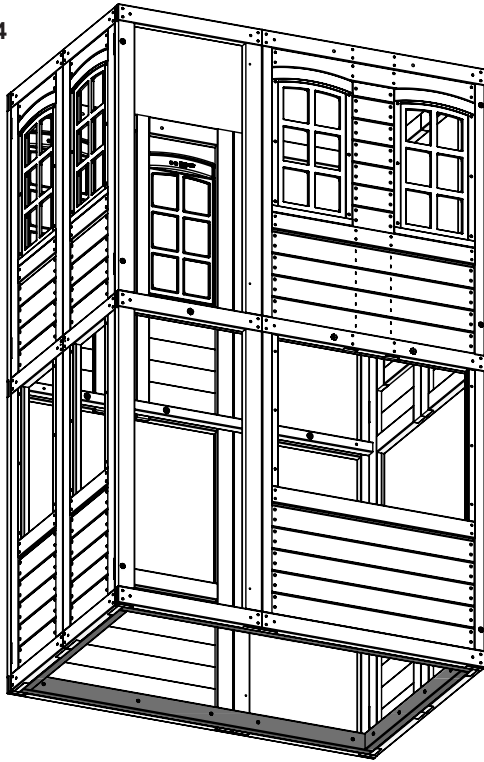
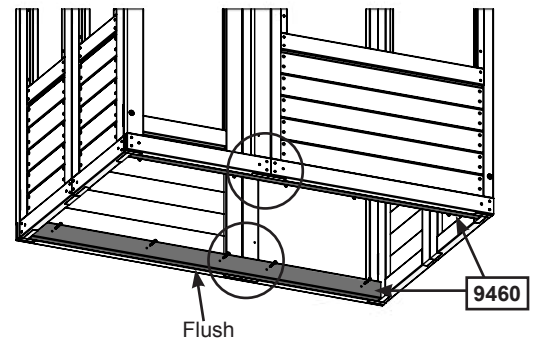
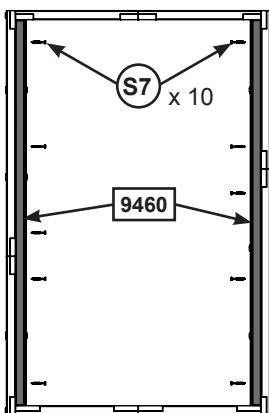

Fig. 3.5



Note hole orientation in Fig. 3.7,
3 screws into large panel and 2
into the small panel.

Fig. 3.7



Bottom View

Fig. 3.8

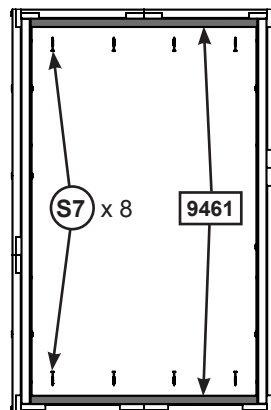

Bottom View

Fig. 3.6

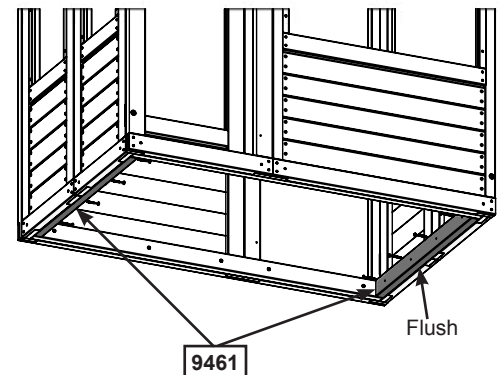

Wood Parts

- 2 x 9460 Floor Joist 1-1/4 x 2-1/2 x 53-3/8"
- 2 x 9461 Floor Joist Short 1-1/4 x 2-1/2 x 31-3/8"

Hardware

- 18 x S7 #12 x 2" Pan Screw

Step 3: Join Frame Assemblies Part 3



E: Place 1 (9460) Floor Joist along the top of the front and back walls so they are flush to the top. Check to make sure that the joists are level then attach each joist using 5 (S7) #12 x 2" Pan Screws. (fig.3.9 and 3.10)

F: Place 1 (9461) Floor Joist Short along the top of each end wall, between the (9460) Floor Joists. Check to make sure they are level and flush to the top, then attach using 4 (S7) #12 x 2" Pan Screws per side. (fig. 3.9 and 3.11)

Fig. 3.9

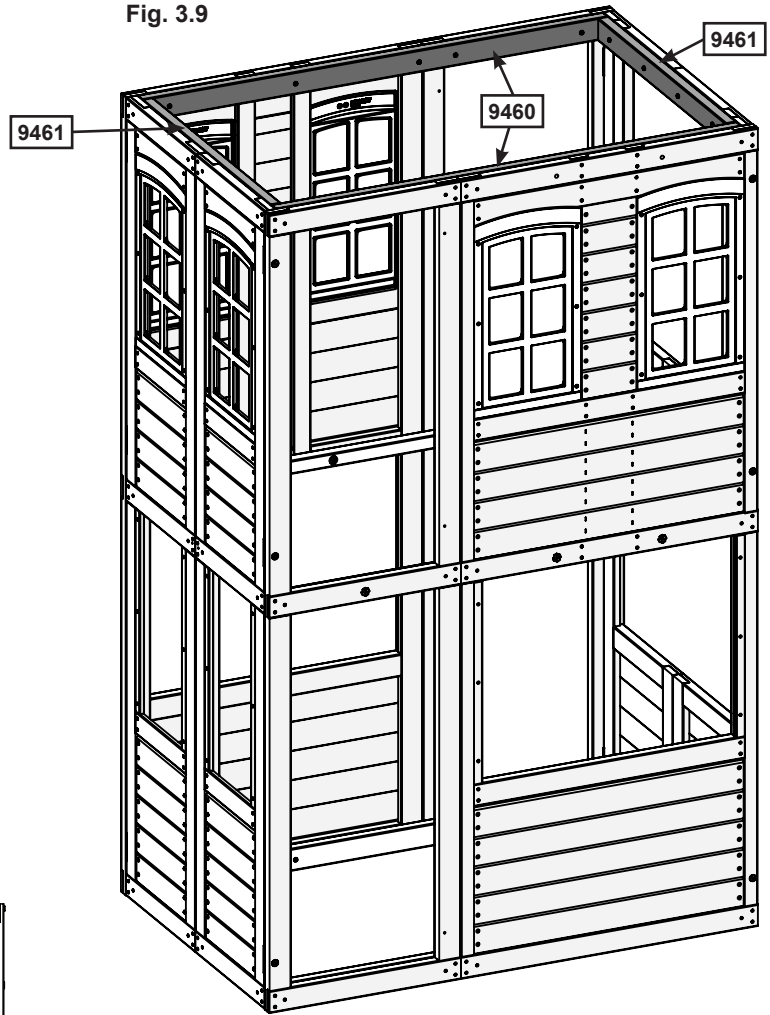

Note hole orientation

Top View

Fig. 3.10

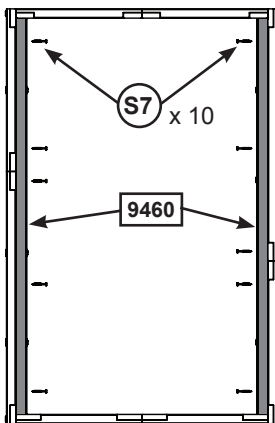

Note hole orientation

Fig. 3.11

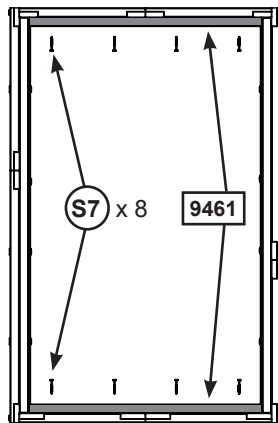

Wood Parts

- 2 x 9460 Floor Joist 1-1/4 x 2-1/2 x 53-3/8"
- 2 x 9461 Floor Joist Short 1-1/4 x 2-1/2 x 31-3/8"

Hardware

- 18 x S7 #12 x 2" Pan Screw

Step 4: Floor Assembly Part 1

A: Place 1 (9463) Floor Board tight to one End Wall and 1 (9518) Floor Board B tight to the opposite End Wall. Attach each board to the (9462) Side Joists using 4 (S20) #8 x 1-3/8" Wood Screws per board. (fig. 4.1 & 4.2)

B: Place (9464) Floor Support A tight to the bottom of each Floor Board, centred over the pilot holes on the End Walls, then attach with 2 (S4) #8 x 3" Wood Screws per side. Attach (9463) Floor Board and (9518) Floor Board B to (9464) Floor Support A with 2 (S20) #8 x 1-3/8" Wood Screws per board. (fig. 4.1, 4.3 , 4.4)

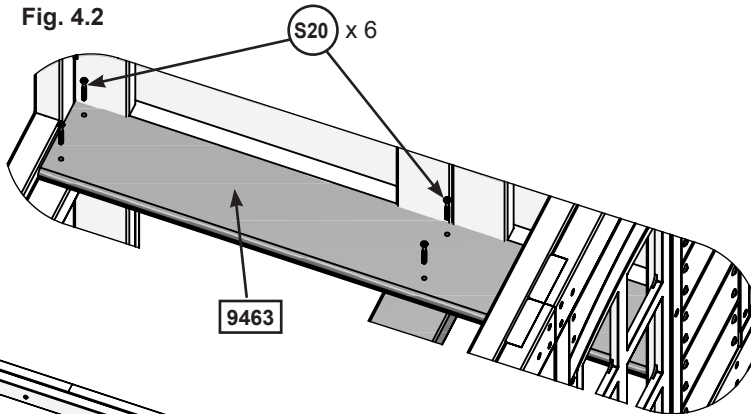

Fig. 4.1

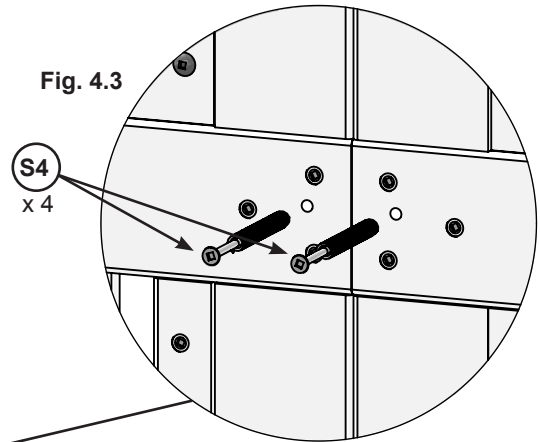
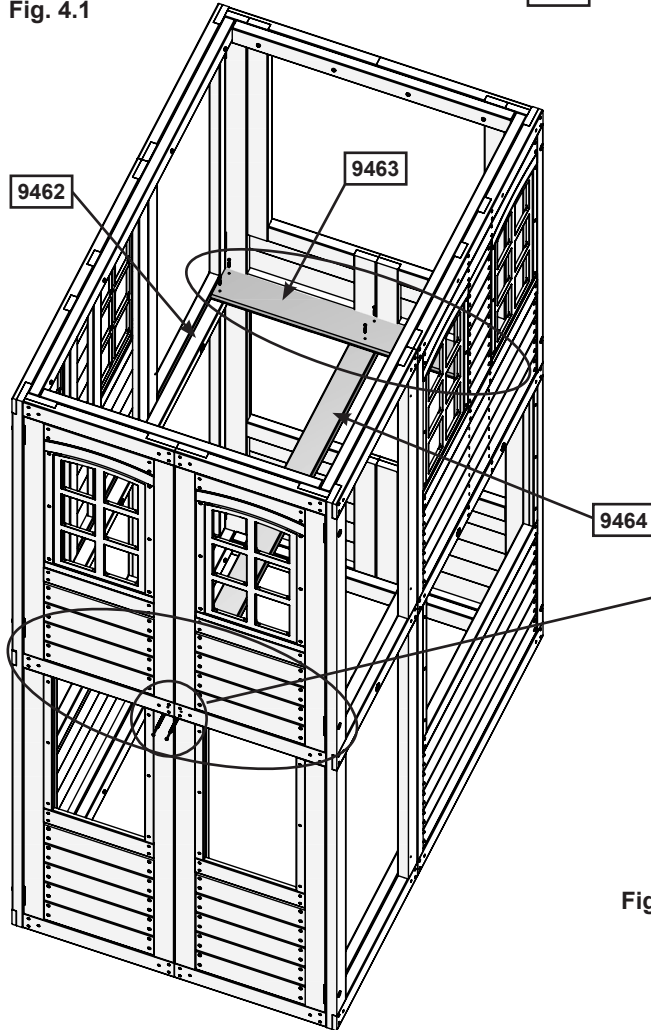

Fig. 4.3

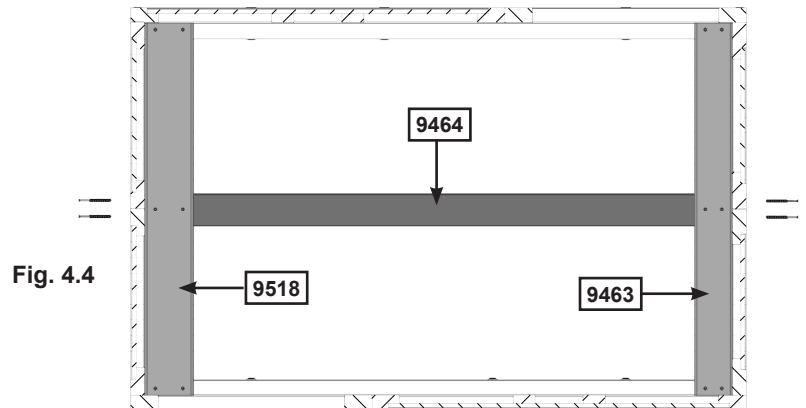

Fig. 4.4

Wood Parts

- 1 x 9464 Floor Support A 1-1/4 x 3 x 62-13/64"
- 1 x 9463 Floor Board 5/8 x 3-3/8 x 34-3/8"
- 1 x 9518 Floor Board B 5/8 x 5-1/4 x 35"

Hardware

- 4 x S4 #8 x 3" Wood Screw
- 12 x S20 #8 x 1-3/8" Wood Screw

Step 4: Floor Assembly Part 2

C: Evenly space the remaining 10 (9463) Floor Boards and attach each board using 6 (S20) #8 x 1-3/8" Wood Screws. (fig. 4.5 & 4.6)

Top View

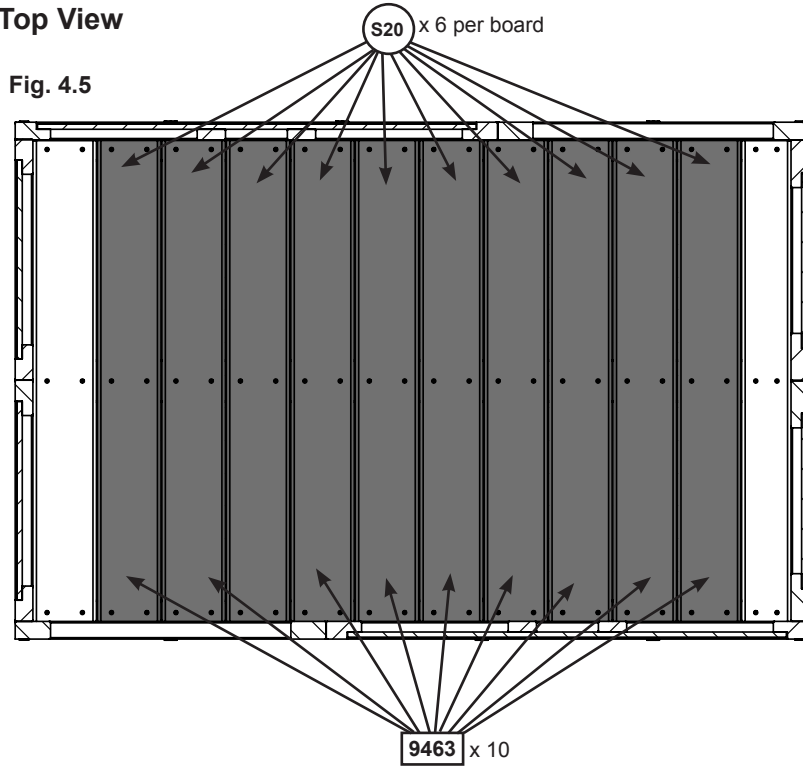
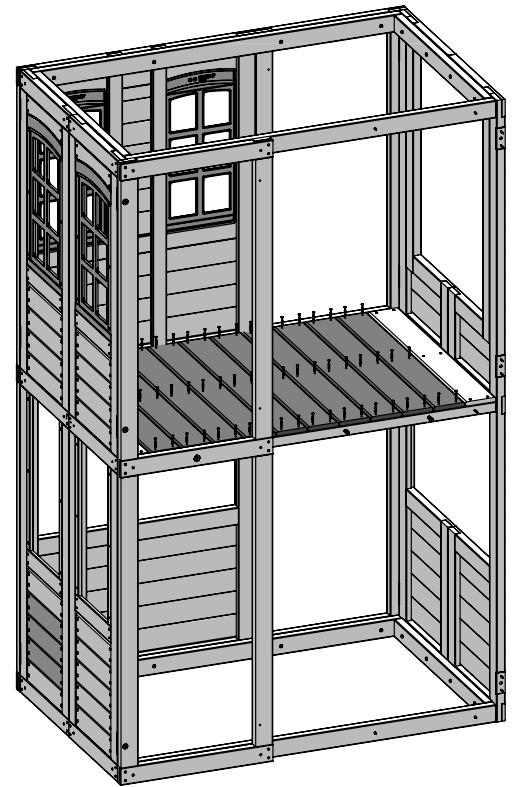

Fig. 4.6



Wood Parts

10 x 9463 Floor Board 5/8 x 5-1/4 x 34"

Hardware

60 x S20 #8 x 1-3/8" Wood Screw

Step 5: Door Assembly Part 1



- A:** On the outside edge of the (9262) Door, measure 2.6" (66mm) down from the top of the door and install 1 Door Handle using 2 (S37) #7 x 5/8" Pan Screws. (fig. 5.1)
- B:** At the opposite end of the door panel, measure 3" (76.2mm) down from the top of the door and install 1 Door Hinge using 3 (S37) #7 x 5/8" Pan Screws. Measure 3" (76.2mm) up from the bottom of the Door Panel to install a bottom Door Hinge using 3 (S37) #7 x 5/8" Pan Screws. (fig 5.3)
- C:** On the inside edge of (9262) Door, measure 2.6" (66mm) down from the top of the door and install 1 Door Handle using 2 (S37) #7 x 5/8" Pan Screws. (fig. 5.1)
- D:** Measure 6.5" (165mm) inches down from the top of the inside edge to install a Catch Plate using 2 (S38) #7 x 1- 1/8" Pan Screws, making sure that Catch Plate is flush to the edge of the door frame. (fig 5.2)
- E:** On the outside bottom edge of the (9262) Door measure 1" up from the bottom and install 1 Door Bumper using 1 (S0) #8 x 7/8" Truss Screw. There should be a measurement of 5/8" from the back of (9262) Door to the screw hole.(Fig. 5.4)

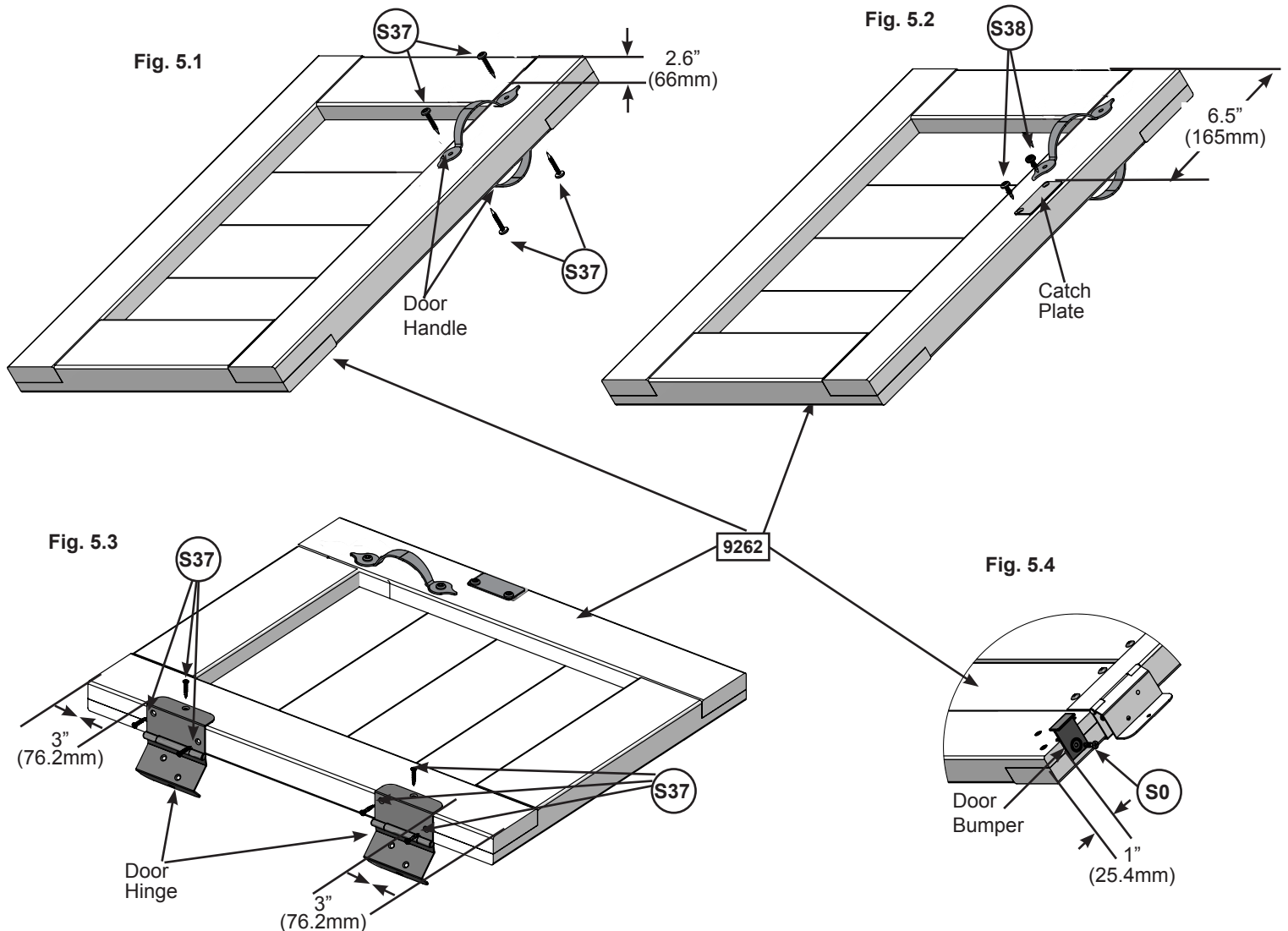

Wood Parts

1 x 9262 Door

10 x S37 #7 x 5/8" Pan Screw
 2 x S38 #7 x 1-1/8" Pan Screw
 1 x S0 #8 x 7/8" Truss Screw

Other Parts

2 x Door Handle
 2 x Door Hinge
 1 x Catch Plate
 1x Door Bumper

Step 5: Door Assembly Part 2

F: In the opening for the door put Dutch Door Assembly in place, measuring to ensure that it is 5/8" (15.9mm) up from the bottom frame (fig. 5.5). Attach hinges to the Wall Frame using 3 (S37) #7 x 5/8" Pan Screws per hinge as shown in fig. 5.6 and 5.5.

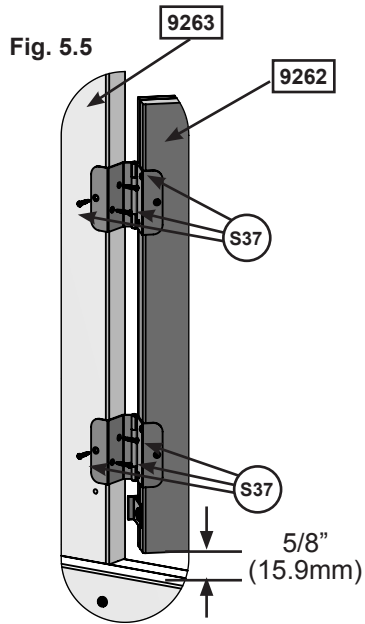
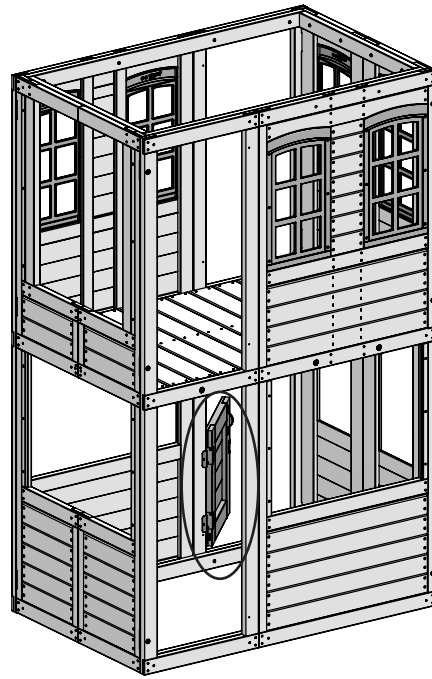



Fig. 5.6



Hardware

6 x  #7 x 5/8" Pan Screw

Step 5: Door Assembly Part 3



G: In the notched out opening of (9513) Door Stop attach the Magnetic Catch using 2 (S38) #7 x 1-1/8" Pan Screws. (fig. 5.7)

Important: Use a hand held screw driver and **DO NOT** over tighten.

H: On the inside of the assembly, attach (1913) Door Stop to (9263) Folding Panel Assembly Right A with 3 (S11) #8 x 2" Wood Screws, making sure (1913) Door Stop overhangs by 1-1/4" (32mm) and is in position to receive the Catch Plate. (fig. 5.8 , 5.9)

Fig. 5.7

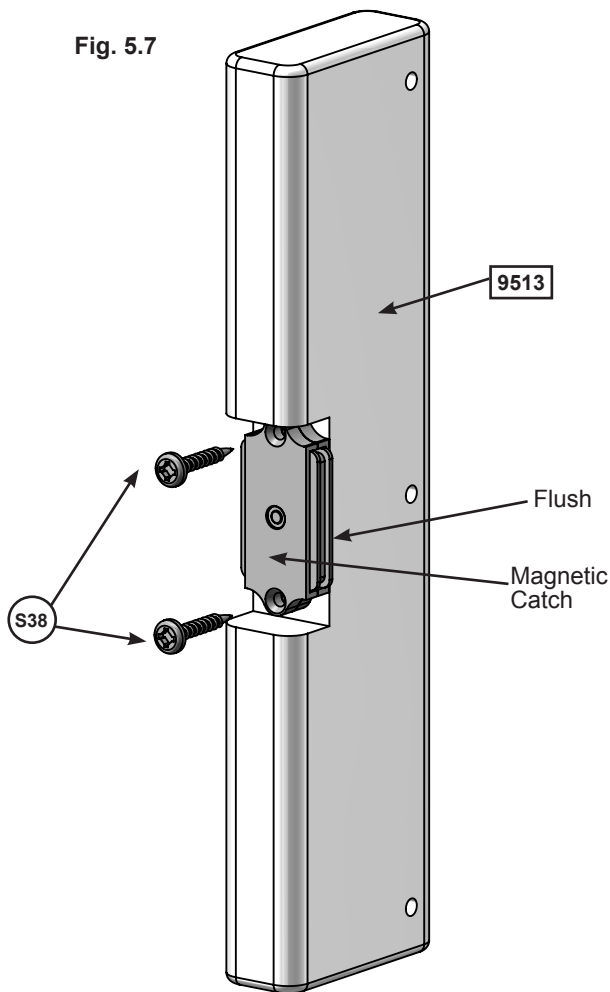

Fig. 5.8

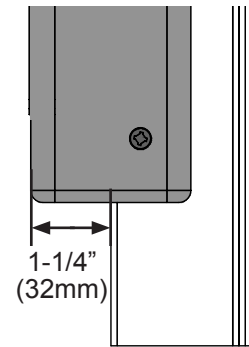
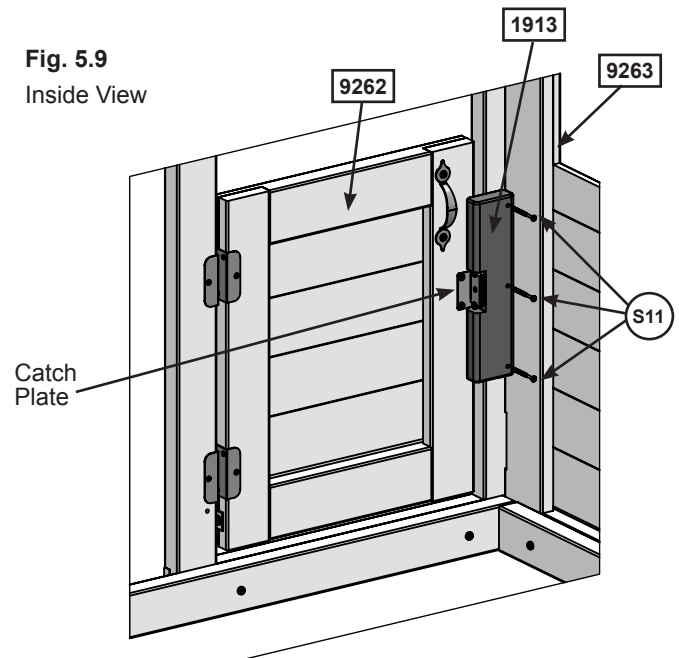

Fig. 5.9
Inside View



Wood Parts

1 x 9513 Door Stop 1 x 2-1/2" x 10"

Hardware

3 x S11 #8 x 2" Wood Screw

2 x S38 #7 x 1-1/8" Pan Screw

Other Parts

1 x Magnetic Catch

Step 6: Attach Wall Tops Part 1

A: From outside of the assembly, place 1 (9516) Table Top Short in the narrow openings of (9263) Folding Panel Assembly Right A and (9265) Folding Panel Assembly Left B. Attach with 2 (S11) #8 x 2" Wood Screws per board. (fig 6.1)

Fig. 6.1

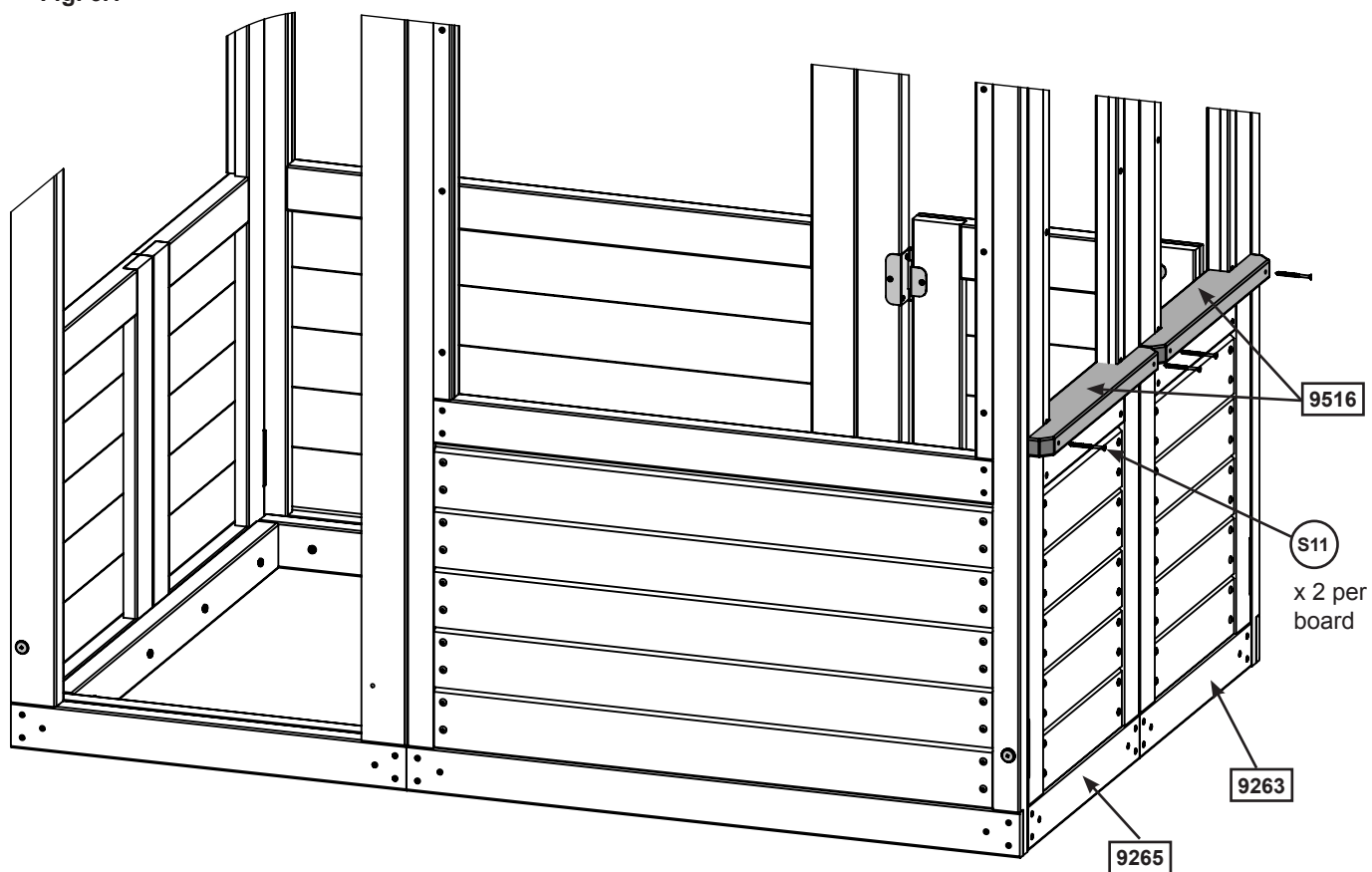

Wood Parts

2 x 9516 Table Top Short 1 x 2-1/2 x 17-1/16"

Hardware

4 x S11 #8 x 2" Wood Screw

Step 6: Attach Wall Tops Part 2

B: Place (9515) Table Top into the opening on the back of (9265) Folding Panel Assembly Left B and attach using 4 (S11) #8 x 2" Wood Screws. (fig. 6.2)

Fig. 6.2

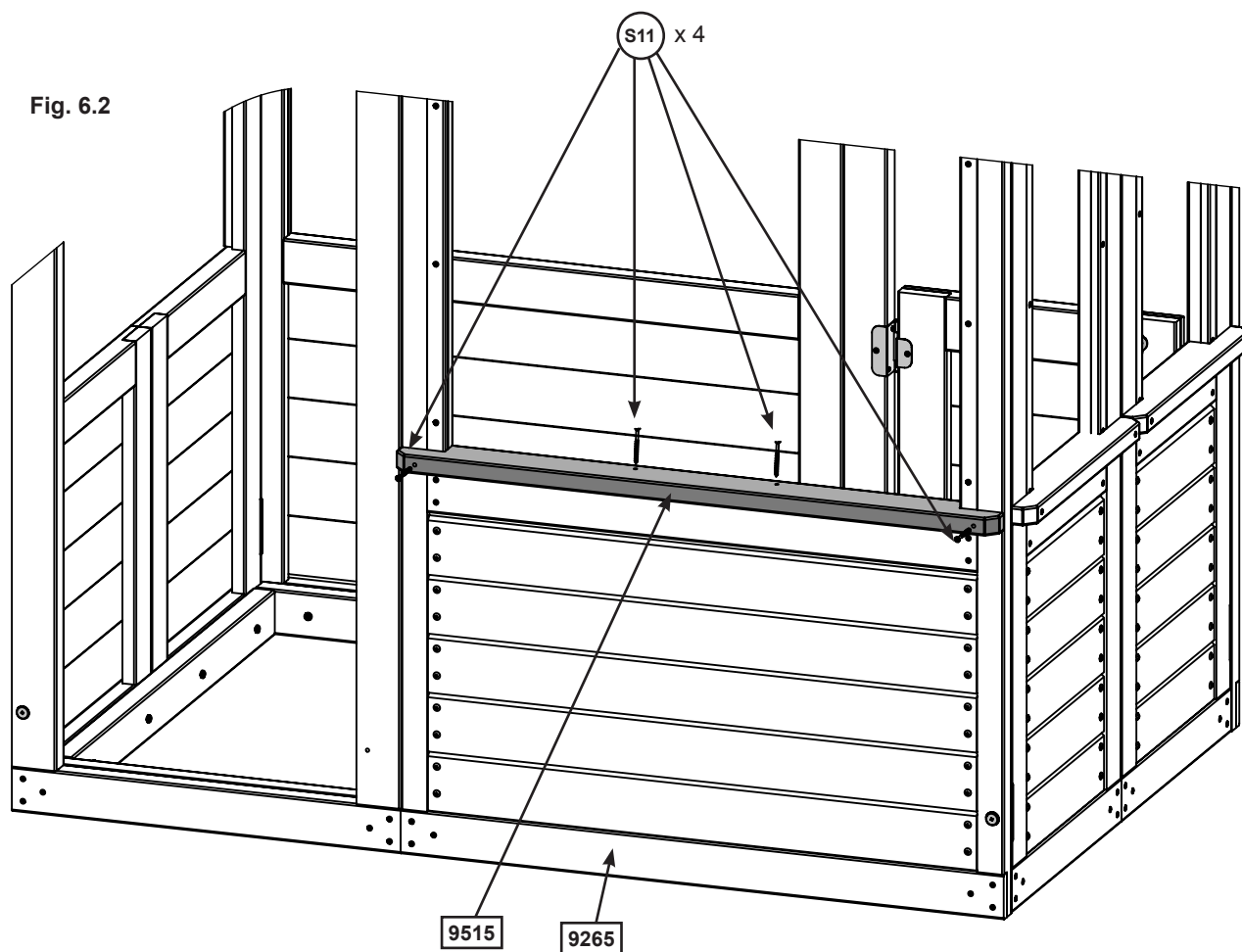

Wood Parts

1 x 9515 Table Top 1 x 2-1/2 x 34-1/8"

Hardware

4 x S11 #8 x 2" Wood Screw

Step 6: Attach Wall Tops Part 3

C: From inside the assembly, place 1 (9515) Table Top into the end wall opening of (9264) Folding Panel Assembly Left A and (9266) Folding Panel Assembly Right B. Attach using 4 (S11) #8 x 2" Wood Screws as shown in fig. 6.3.

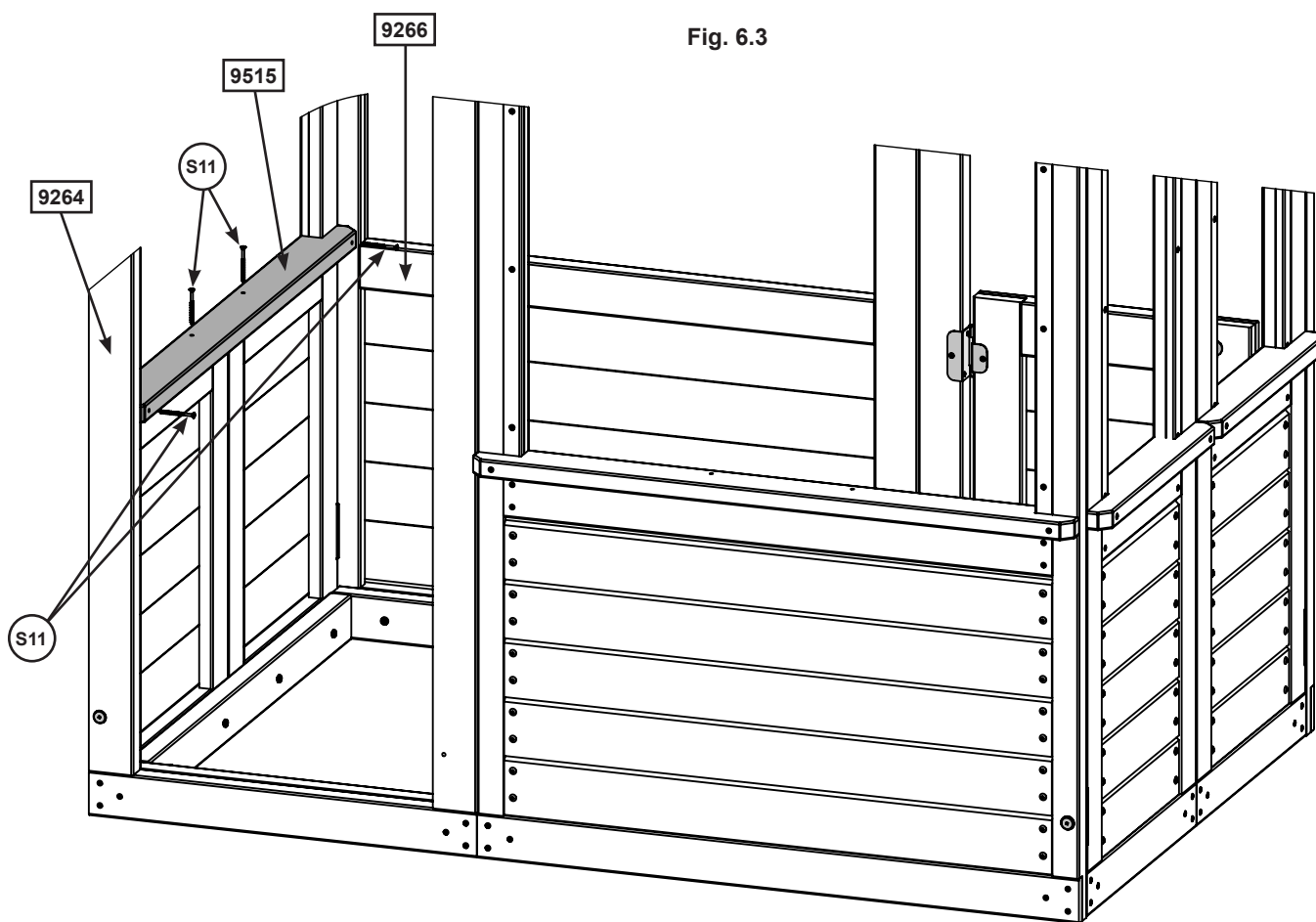

Wood Parts

1 x **9515** Table Top 1 x 2-1/2 x 34-1/8"

Hardware

4 x **S11** #8 x 2" Wood Screw

Step 6: Attach Wall Tops Part 4

D: From outside of the assembly, place 1 (9515) Table Top into the front opening of (9266) Folding Panel Assembly Right B. Attach using 4 (S11) #8 x 2" Wood Screws fig. 6.4.

Fig. 6.4

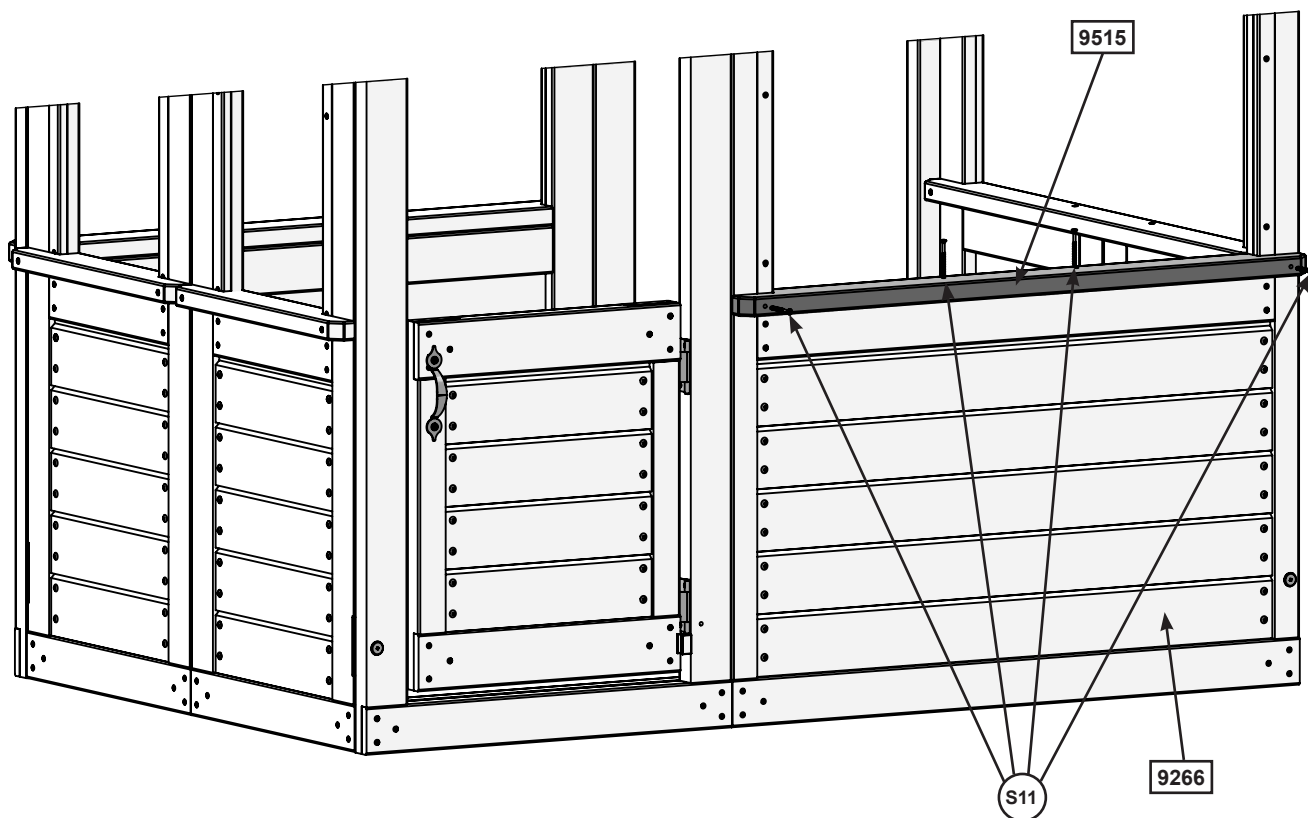

Wood Parts

1 x 9515 Table Top 1 x 2-1/2 x 34-1/8"

Hardware

4 x S11 #8 x 2" Wood Screw

Step 7: Counter Assembly

Part 1



A: Flush to each end and to the bottom of (9473) Counter Back attach 1 (9471) Counter Joist per end with 1 (S2) #8 x 1-1/2" Wood Screw per joist. Notice the holes at the top of (9473) Counter Back. (fig. 7.1 & 7.2)

B: Place the remaining 2 (9471) Counter Joists centered over the pilot holes in the middle of (7613) Counter Back and flush to the bottom of the board. Attach in the bottom holes using 1 (S2) #8 x 1-1/2" Wood Screw per joist. (fig. 7.1 & 7.2).

C: Place (9472) Counter Front against (9471) Counter Joists so the ends are flush and the (9471) Counter Joists are centered over the pilot holes. Measure 5/8" (16mm) down from the top of (9472) Counter Front on both ends and attach to the (9471) Counter Joists with 4 (S2) #8 X 1-1/2" Wood Screws. (fig. 7.1 & 7.2)

Fig. 7.1

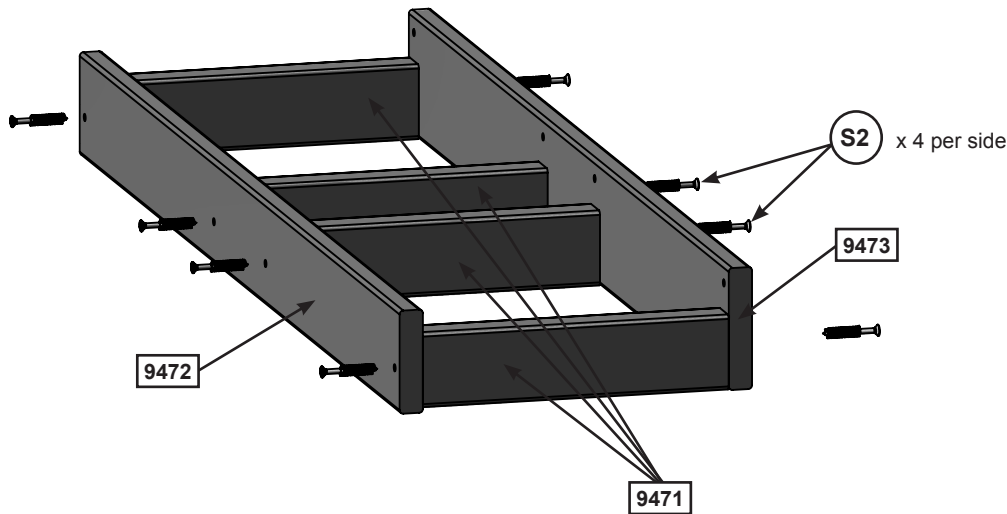
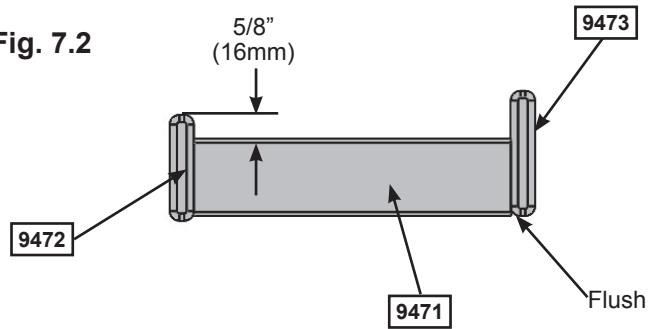

Fig. 7.2



Wood Parts

- 4 x 9471 Counter Joist 1 x 2 x 8-1/4"
- 1 x 9472 Counter Front 5/8 x 2-3/4 x 32-3/16"
- 1 x 9473 Counter Back 5/8 x 3-1/4 x 32-3/16"

Hardware

- 8 x S2 #8 x 1-1/2" Wood Screw

Step 7: Counter Assembly

Part 2

D: Place 1 (9470) Counter Brace tight to the bottom of each outside (9471) Counter Joist, tight to (9472) Counter Front and attach using 1 (S3) #8 x 2-1/2" Wood Screw per brace. (fig 7.3 & 7.4 & 7.5)

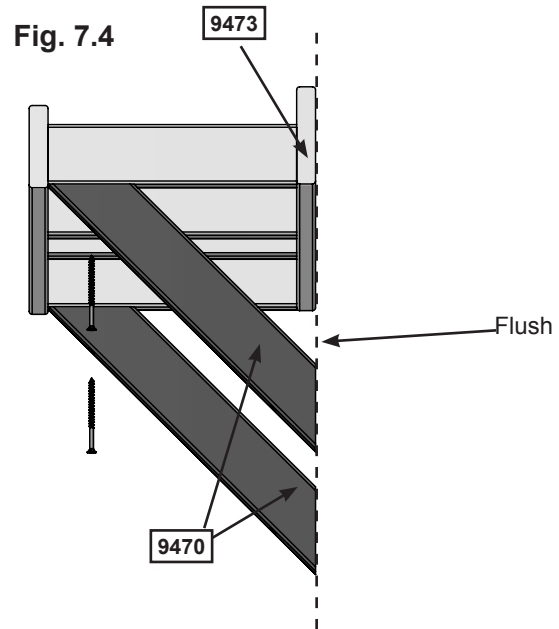
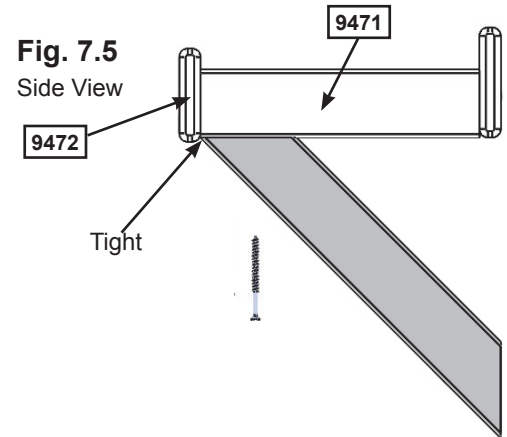
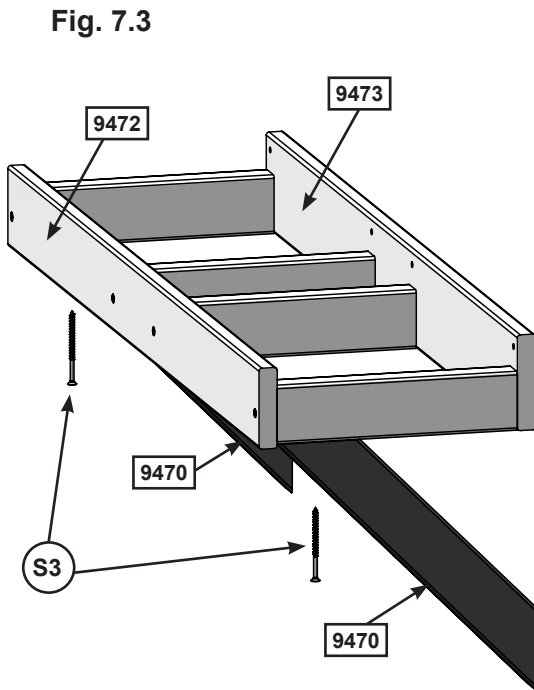

Wood Parts

2 x 9470 Counter Brace 1 x 2 x 12-1/2"

Hardware

2 x S3 #8 x 2-1/2" Wood Screw

Step 8: Attach Counter Assembly Part 1

- A:** On the inside of the assembly place Counter Assembly against the Cafe Wall flush to the opening. (fig 8.1)
- B:** Attach (9473) Counter Back to Cafe Wall with 4 (S2) #8 x 1-1/2" Wood Screws. (fig 8.1)
- C:** Attach both (9470) Counter Braces to Cafe Wall with 1 (S3) #8 x 2-1/2" Wood Screw per brace. (fig 8.1)

Fig. 8.1

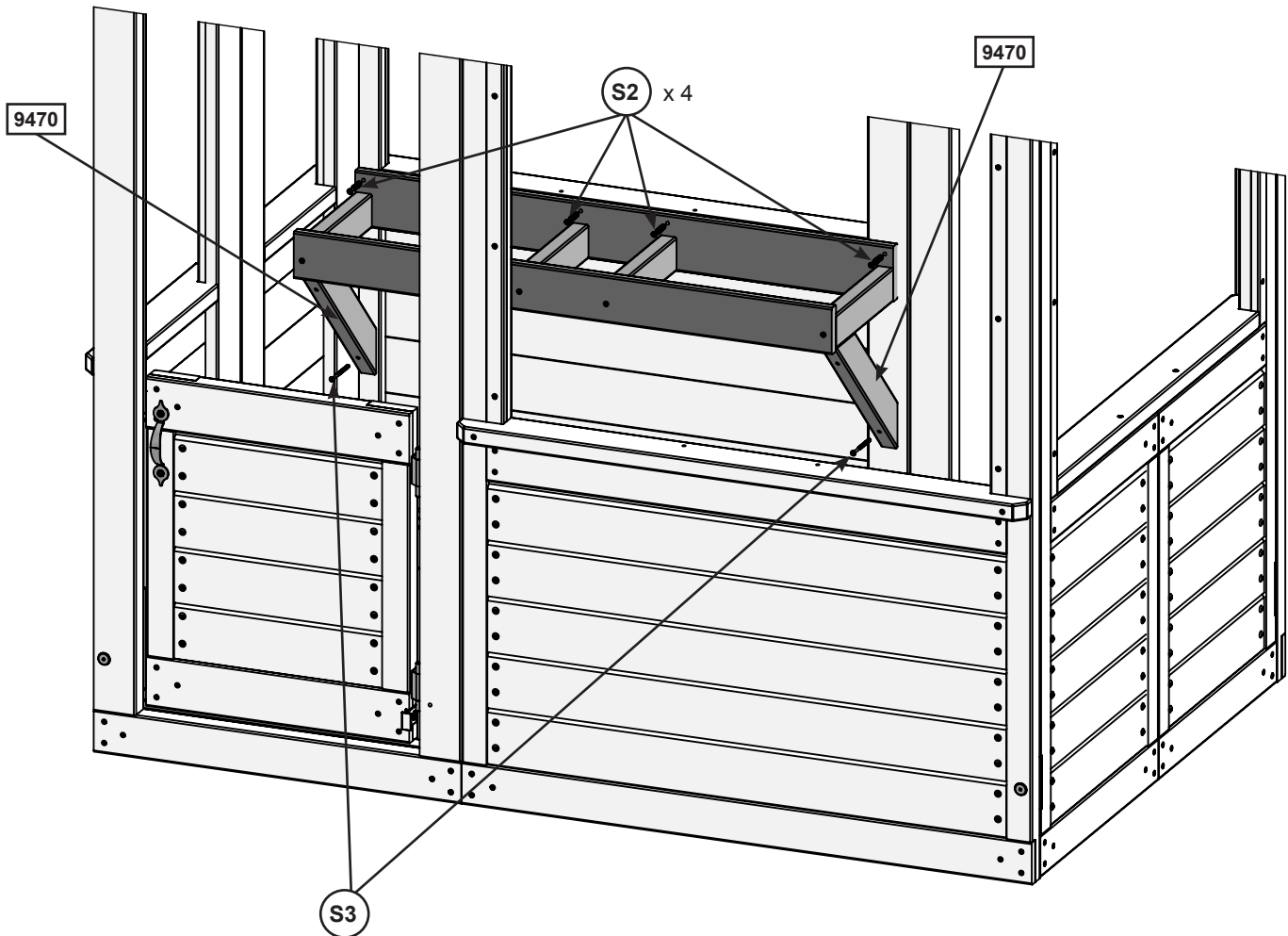

Hardware

- 4 x (S2) #8 x 1-1/2" Wood Screw
2 x (S3) #8 x 2-1/2" Wood Screw

Step 8: Attach Counter Assembly Part 2

D: Tight to (9473) Counter Back attach (9474) Counter Top to each (9471) Counter Joist with 4 (S38) #7 x 1-1/8" Pan Screws. (fig. 8.2)

E: Tight to (9474) Counter Top and flush to the outside edges of the outer (9471) Counter Joists attach 1 (9476) Counter Side per joist with 3 (S38) #7 x 1-1/8" Pan Screws per board. (fig. 8.2)

F: Tight to (9474) Counter Top and centered over the middle 2 (9471) Counter Joists with ends flush to the outside edges, attach 2 (9475) Counter Mid Tops with 4 (S38) #7 x 1-1/8" Pan Screws per board. (fig. 8.2)

Fig. 8.2

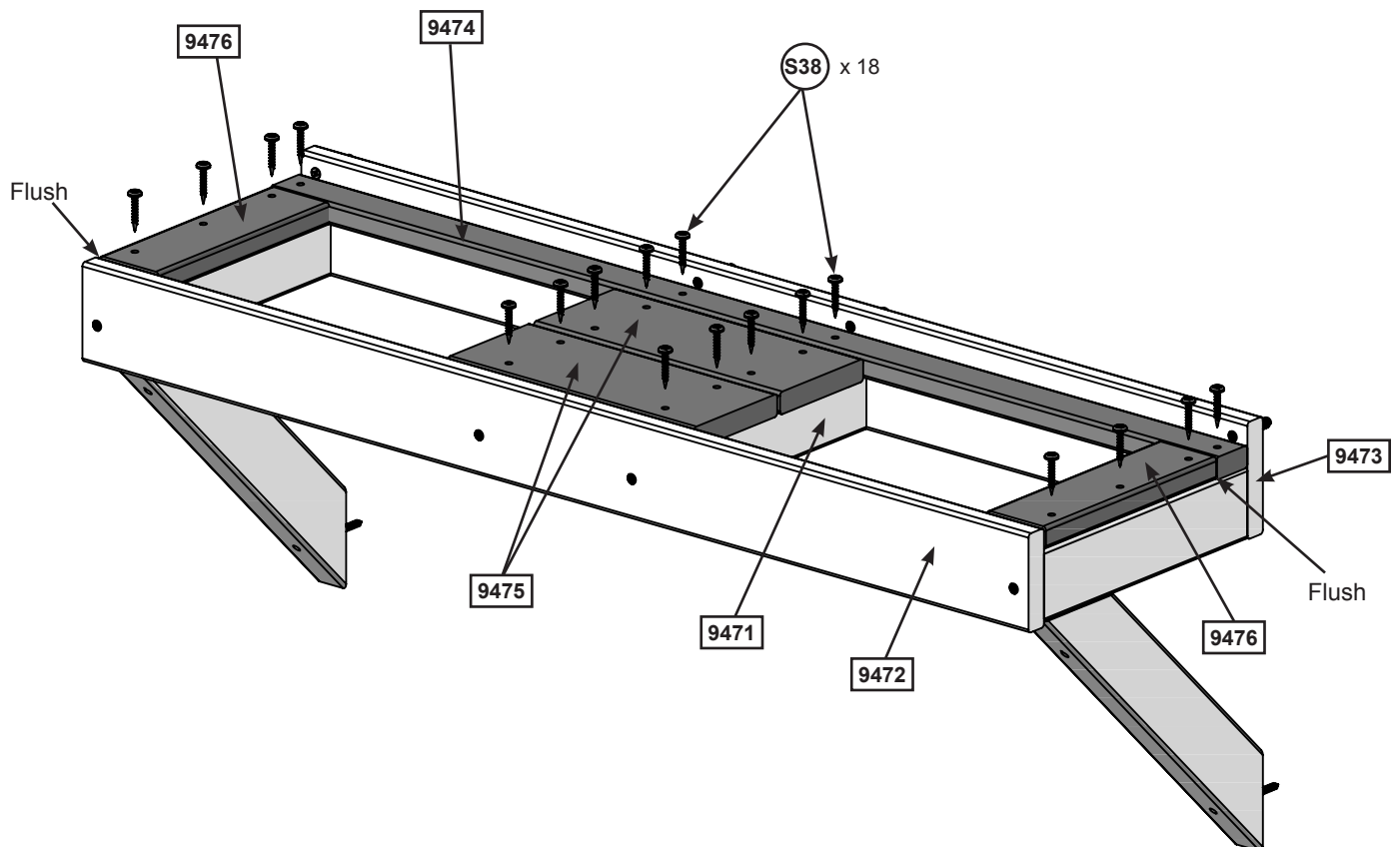

Wood Parts

- 1 x 9474 Counter Top 5/8 x 1-1/4 x 32-3/16"
- 2 x 9475 Counter Mid Top 5/8 x 3-3/8 x 8-3/8"
- 2 x 9476 Counter Side 5/8 x 2 x 6-59/64"

Hardware

- 18 x (S38) #7 x 1-1/8" Pan Screw

Step 8: Attach Counter Assembly Part 3

G: Place Faucet and 2 Sink Knobs in opening of Sink and attach Sink Knobs with included hardware. (fig. 8.3)
Important: Use a hand held screw driver and **DO NOT** over tighten.

Fig. 8.3

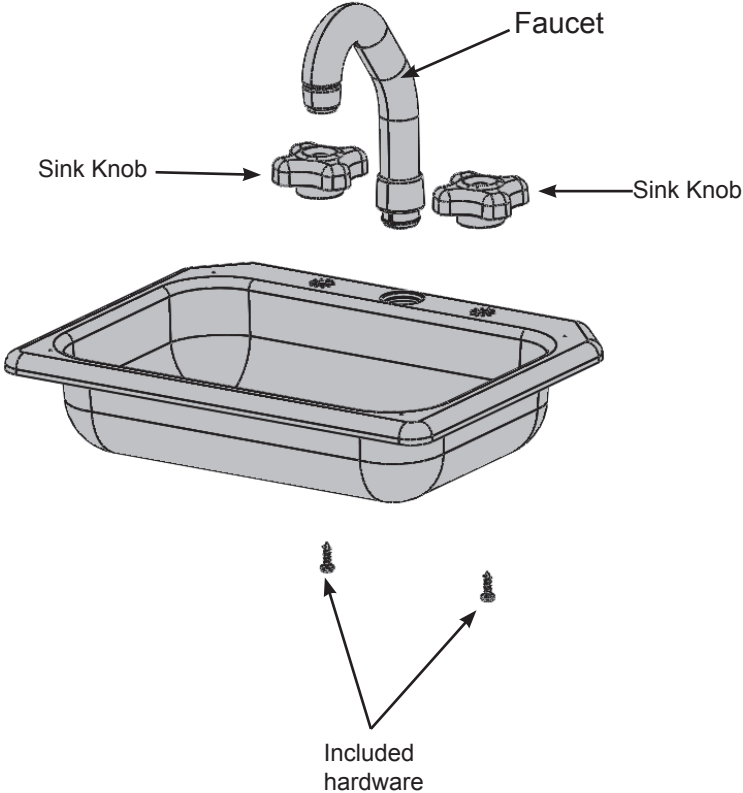

Other Parts

- 1 x Sink
- 2 x Sink Knobs
- 1 x Faucet

Step 8: Attach Counter Assembly Part 4

H: Place Sink and Stove in the openings of the Counter Assembly then attach 4 Mount Clips with included hardware to the bottom of the Sink and Stove to secure in place. (fig. 8.4 and 8.5)

Important: Use a hand held screw driver and **DO NOT** over tighten.

Note: To remove the Sink or Stove loosen screw 1/4 turn then twist Mount Clips

Fig. 8.4

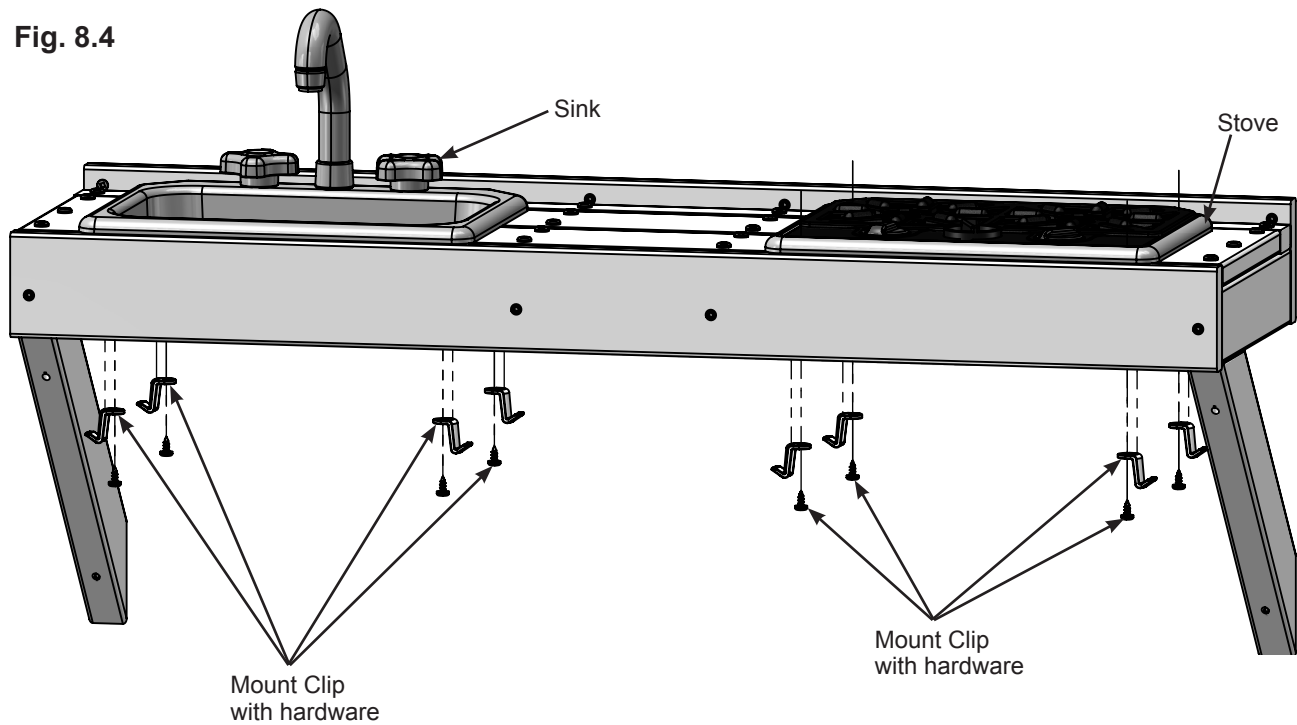
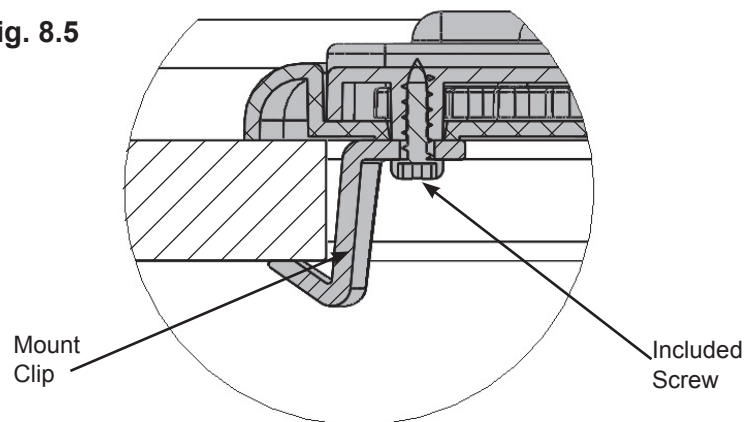

Fig. 8.5



Other Parts

1 x Stove
8 x Mount Clip

Step 9: Attach Utensil Shelf

A: From inside the assembly attach 1 Utensil Shelf with 2 (S0) #8 x 7/8" Truss Screws as shown in fig. 9.1 & 9.2.

B: Attach the Pot, Pan and Spatula to Utensil Shelf. (fig. 9.2)

Fig. 9.1

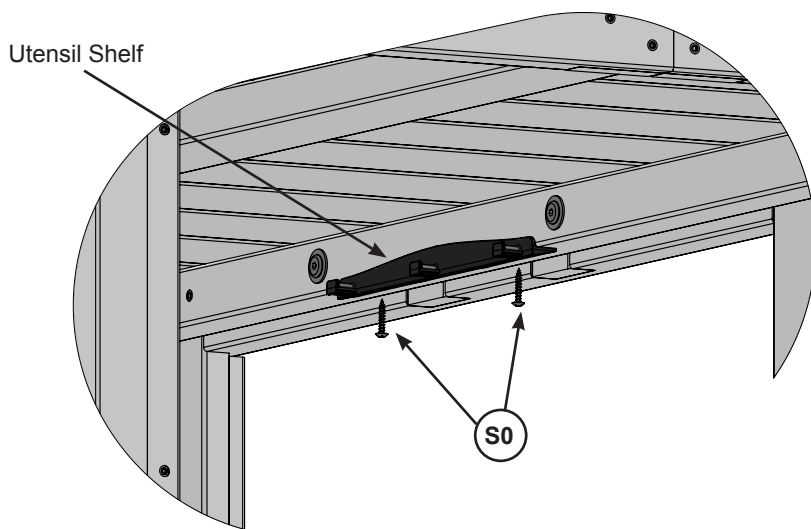
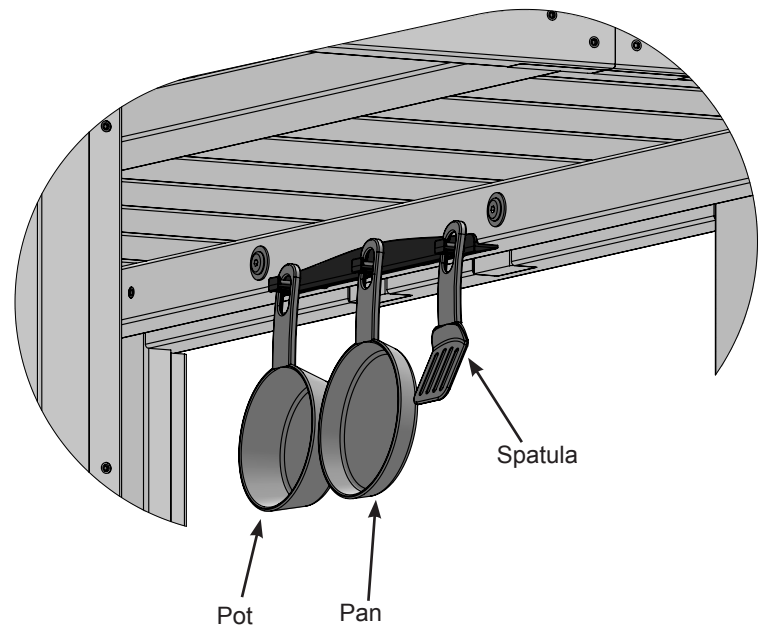

Fig. 9.2



Hardware

2 x (S0) #8 x 7/8" Truss Screw

Other Parts

1 x Pan
1 x Pot
1 x Spatula
1 x Utensil Shelf

Step 10: Crowsnest Assembly

A: Lay flat 2 (9494) Crowsnest Uprights taking note of the hole orientation. Place 2 (9499A) Crowsnest Bottoms over the top two sets of pre-drilled holes as shown in (Fig.10.1). Attach using 2 (H3) 1/4 x 2-1/2" Hex Bolts (with flat washer, lock washer and t-nut) per board. (Fig. 10.1)

B: Place (9499) Crowsnest Bottom over the bottom set of pre-drilled holes, attach using 2 (H3) 1/4 x 2-1/2" Hex Bolts (with lock washer, flat washer and t-nut). (Fig. 10.1)

Fig. 10.1

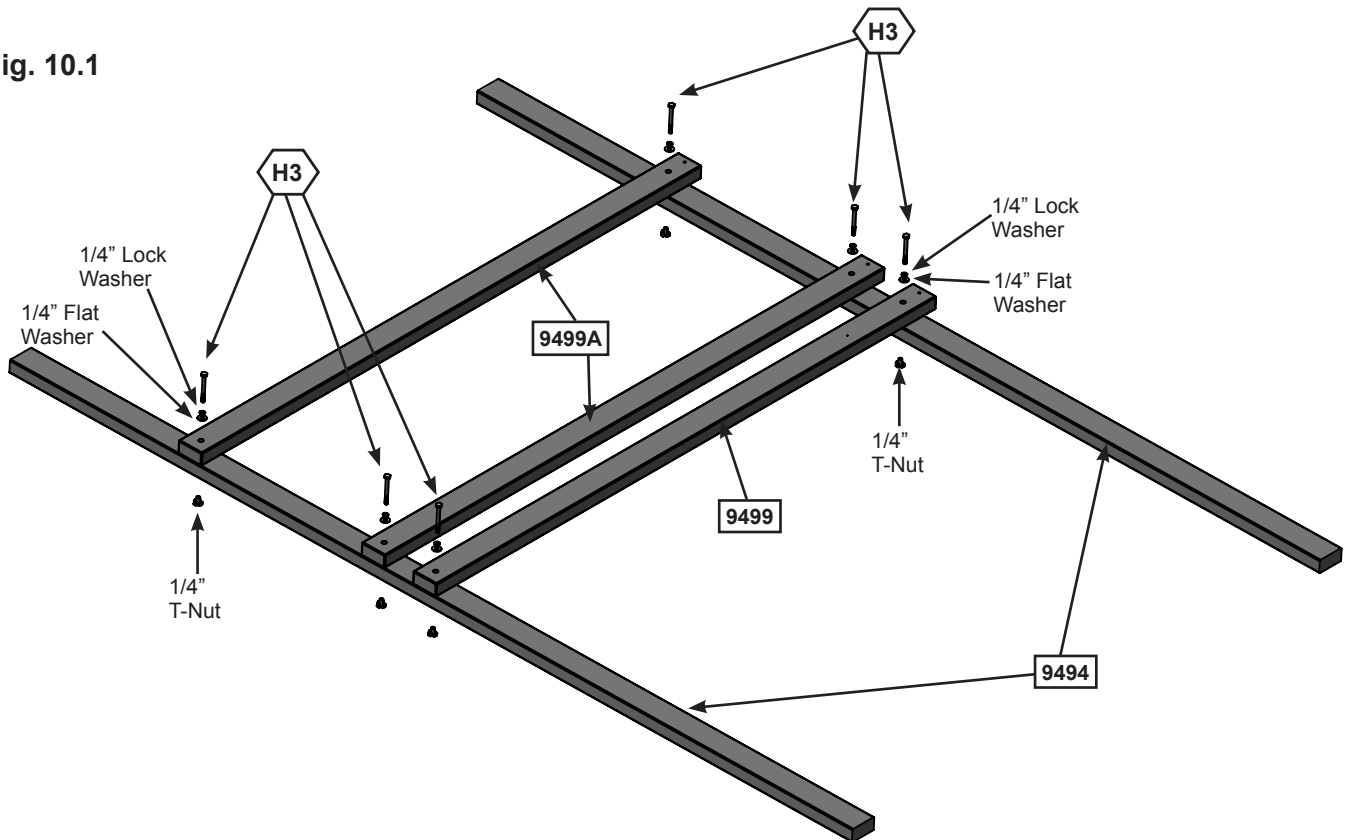

Wood Parts

- 1 x 9499 Crowsnest Bottom 1-1/4 x 2-1/2 x 57-11/64"
- 2 x 9499A Crowsnest Bottom 1-1/4 x 2-1/2 x 57-11/64"
- 2 x 9494 Crowsnest Upright 1-1/4 x 2-1/2 x 90"

Hardware

- 6 x H3 1/4 x 2-1/2" Hex Bolt
(1/4" lock washer, 1/4" flat washer, 1/4" t-nut)

Step 11: Attach Crowsnest Assembly Part 1



A: With a helper, stand the Crowsnest Assembly upright, in front of the fort. Measure to make sure that there is a 21" space between the fort and the outside of (9499) Crowsnest Bottom, as shown in fig. 11.3 & 11.4.

B: Place 1 (9498) Crowsnest Short L across the opening from the fort to the (9494) Crowsnest Upright so that it's flush to the outside edge and the bottom of the lower (9499) Crowsnest Bottom (fig. 11.2). Check to make sure the board is level, then attach using 4 (S3) #8 x 2- 1/2" Wood Screws. (fig. 11.1 & 11.2)

Fig. 11.1

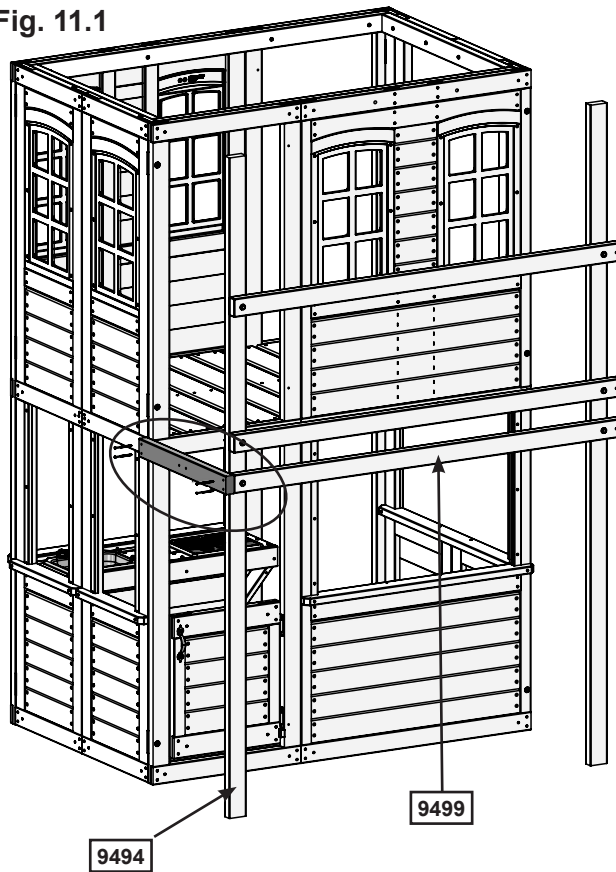

Fig. 11.2

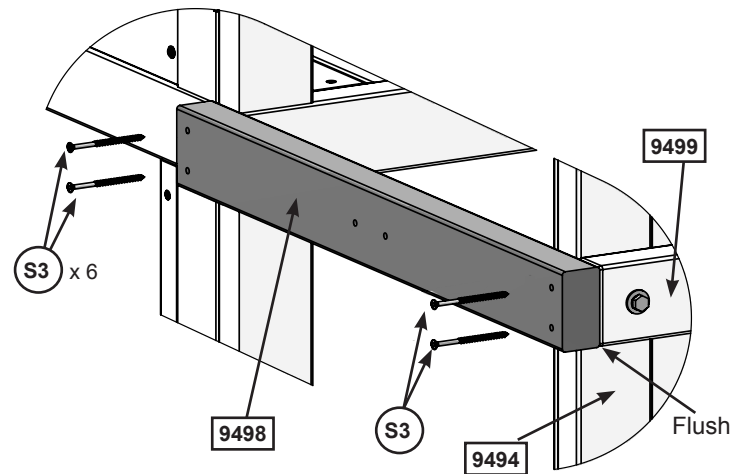

Fig. 11.3

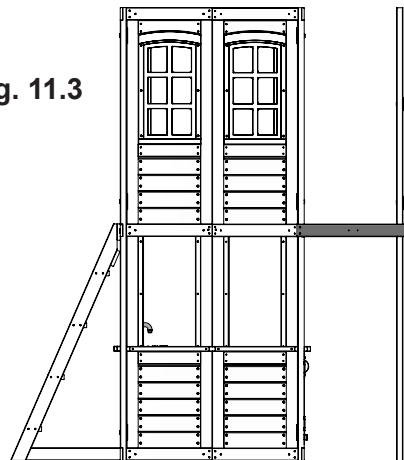
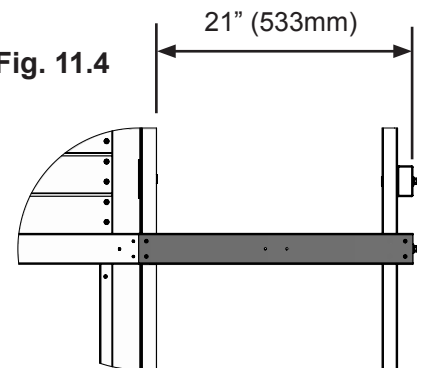

Fig. 11.4



Wood Parts

1 x 9498 Crowsnest Short L 1-1/4 x 2-1/2 x 22-5/16"

Hardware

4 x S3 #8 x 2-1/2" Wood Screw

Step 11: Attach Crowsnest Assembly Part 2

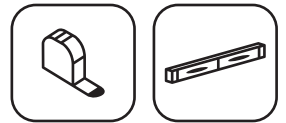

A: In the openings between the (9499A) Crowsnest Bottoms and the fort, attach 2 (9496) Crowsnest Shorts using 5 (S3) #8 x 2- 1/2" Wood Screws per board, making sure that the boards are level and flush with the (9499A) Crowsnest Bottoms. (fig. 11.3 & 11.7)

B: Repeat step A to install (9497) Crowsnest Short A in the location shown. (fig. 11.3 & 11.7)

C: Place (9491) Ground Brace A across the bottom opening so that it's flush to the front of (9494) Crowsnest Upright. Attach to the fort and the upright using 4 (S3) #8 x 2- 1/2" Wood Screws. (fig. 11.3 & 11.5)

Fig. 11.3

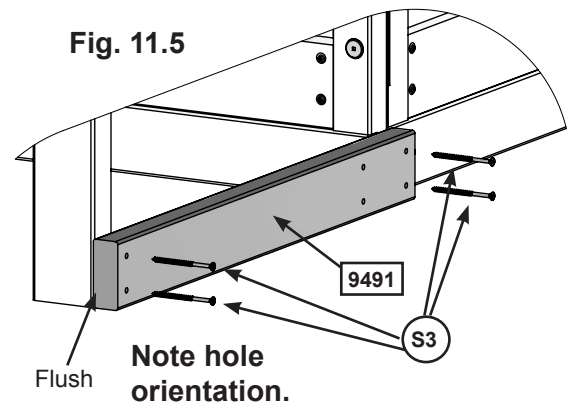
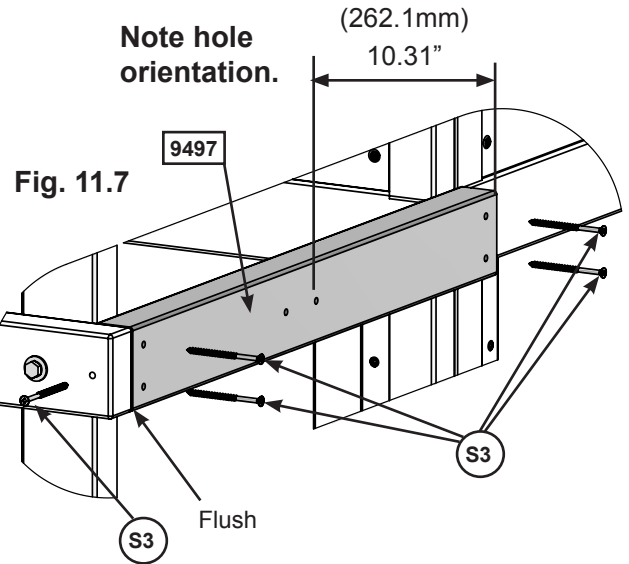
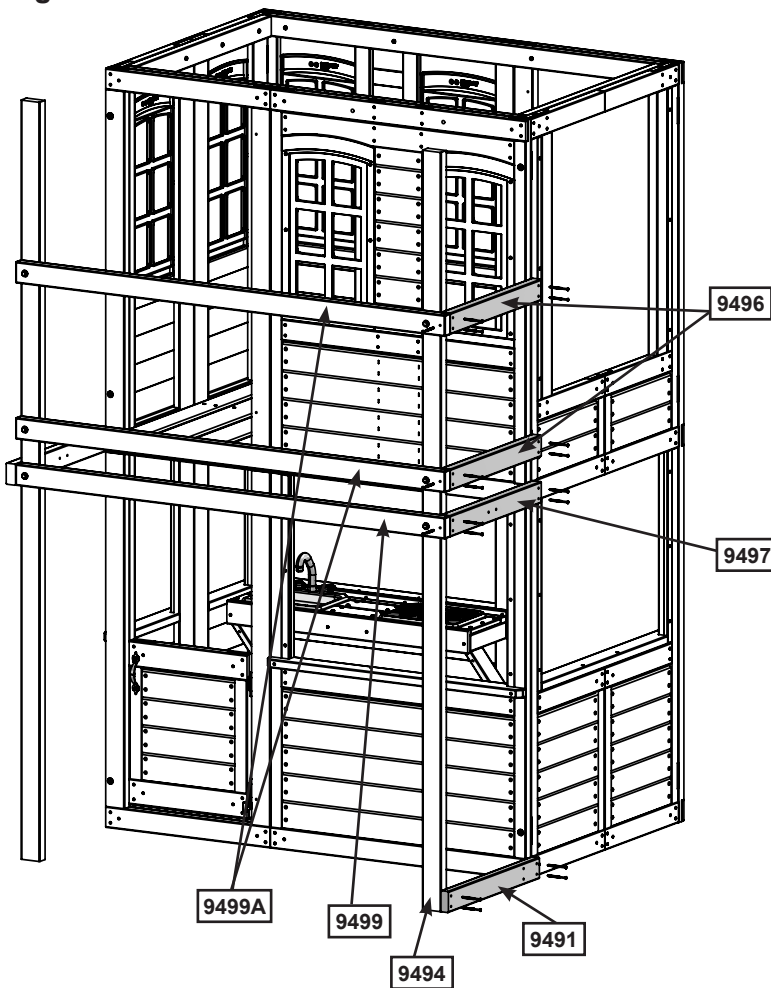

Wood Parts

- 1 x 9491 Ground Brace A 1 x 3-1/8 x 21-1/16"
- 2 x 9496 Crowsnest Short 1-1/4 x 2-1/2 x 21-1/16"
- 1 x 9497 Crowsnest Short A 1-1/4 x 2-1/2 x 21-1/16"

Hardware

- 19 x S3 #8 x 2-1/2" Wood Screw

Step 12: Attach Side Joist

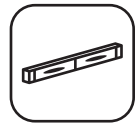

A: On the inside wall of the deck assembly, measure 5/8" down from the top of the door opening and place 1 (9466) Side Joist-2 along the length of the wall. Check to make sure Joist is level, then attach using 5 (S3) #8 x 2-1/2" Wood Screws. (Fig. 12.1 & 12.2)

B: Measure 5/8" down from the top of (9499) Crowsnest Bottom and repeat Step A to install (9465) Side Joist-1 to the opposite side. (Fig. 12.1 & 12.2)

Fig. 12.1

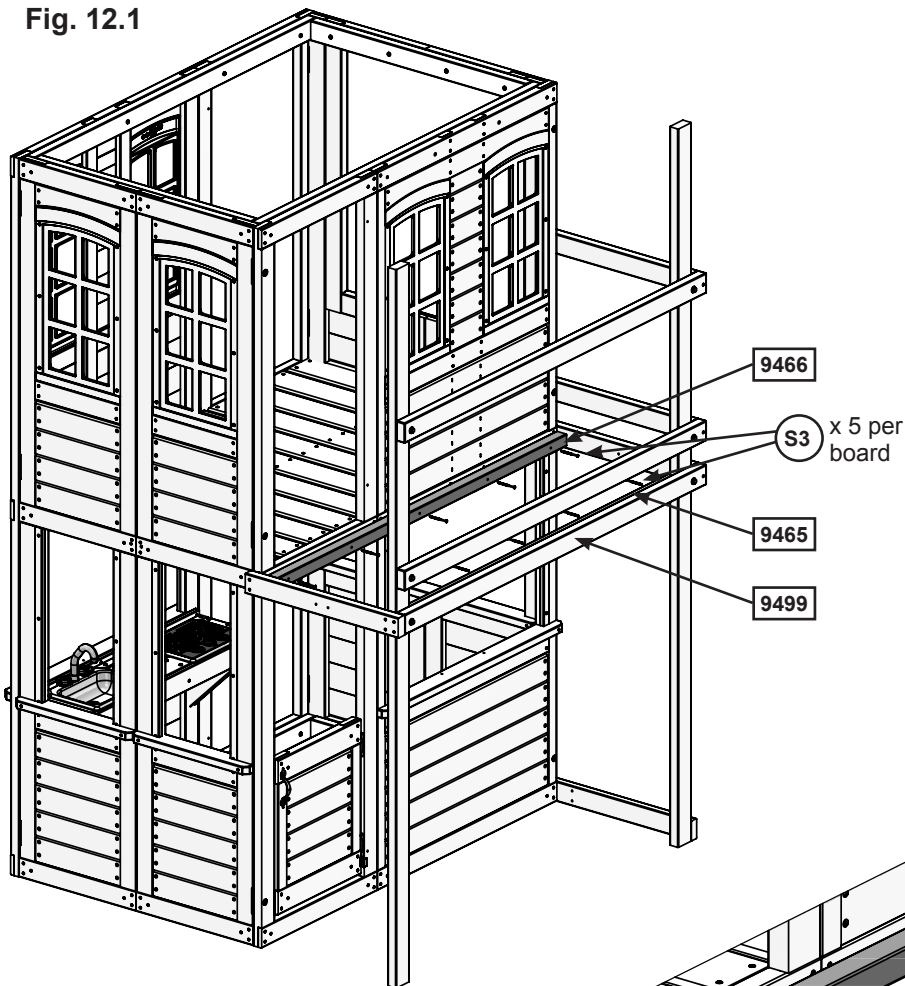
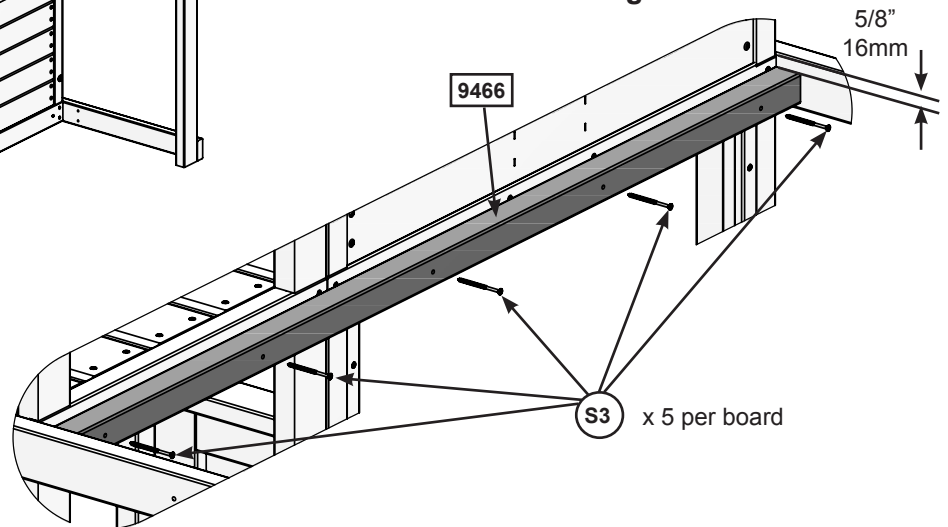

Fig. 12.2



Wood Parts

- 1 x 9465 Side Joist-1 1-1/2 x 1-1/2 x 50-7/8"
- 1 x 9466 Side Joist-2 1-1/2 x 1-1/2 x 55-7/8"

Hardware

- 10 x S3 #8 x 2-1/2" Wood Screw

Step 13: Attach Floor Support



A: Place 1 (9468) Floor Board Short tight to (9497) Crowsnest Short A and a second one tight to (9498) Crowsnest Short L.(fig.13.1 & 13.2 & 13.3)

B: Place (9469) Floor Support tight to the bottom of each Floor Board, centered over the pilot holes on the (9497) Crowsnest End Short A and (9498) Crowsnest End Short I then attach with 2 (S4) #8 x 3" Wood Screws per end. (fig.13.1 & 13.2 & 13.3)

C: Attach each (9468) Floor Board to (9466) Side Joist-2 and (9469) Floor Support using 2 (S20) #8 x 1-3/8" Wood Screws per board. (fig.13.2)

Fig. 13.1

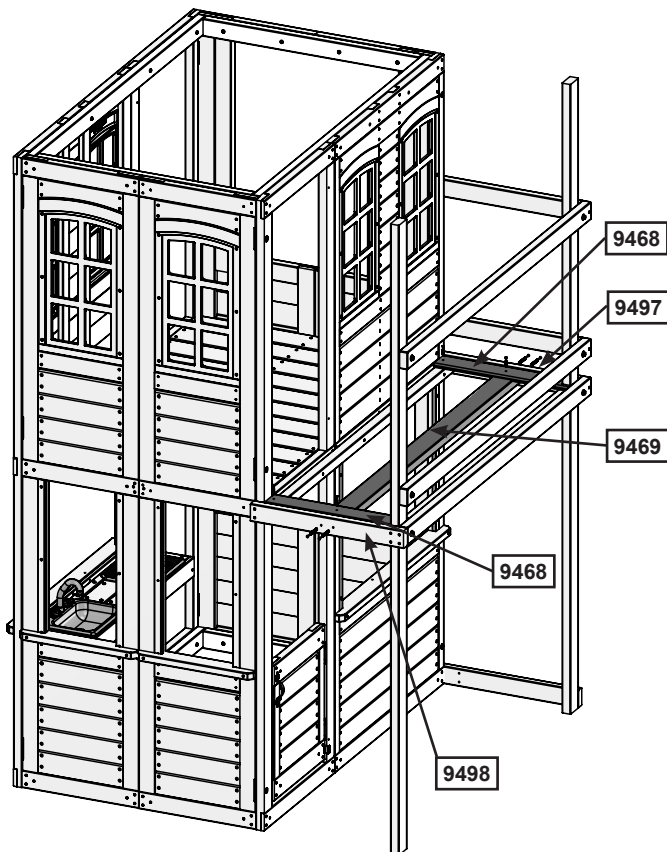

Fig. 13.2

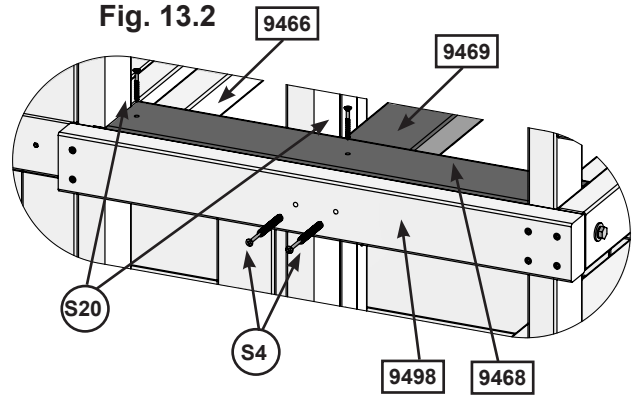
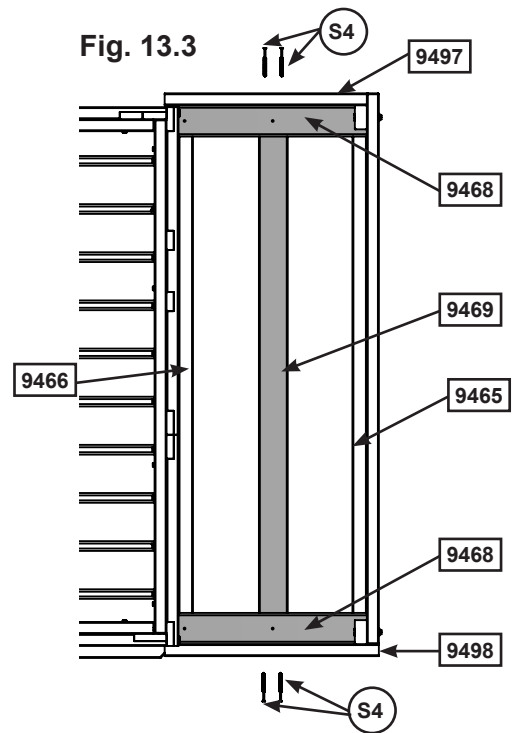

Fig. 13.3



Wood Parts

- 2 x 9468 Floor Board Short-1 5/8 x 3-1/4 x 19-39/64"
- 1 x 9469 Floor Support 1-1/4 x 3 x 56-1/8"

Hardware

- 4 x S20 #8 x 1-3/8" Wood Screw
- 4 x S4 #8 x 3" Wood Screw

Step 14: Chair Assembly



A: Place 1 (9488) Chair Top flush to the edges of 1 (9487) Chair Gusset A, making sure to note the hole orientation. Attach using 1 (S11) #8 x 2" Wood Screw. Repeat to install a second (9487) Chair Gusset on the opposite side. (Fig. 14.1)

B: Install (9489) Chair Top A to (9487) Chair Gusset A's using 2 (S11) #8 x 2" Wood Screws, making sure that the rounded edges are facing outwards.. (Fig. 14.1)

C: Place 1 (9486) Chair Gusset on each end of the (9487) Chair Gusset A's making sure to note the hole orientation. Attach using 1 (S11) #8 x 2" Wood Screw per board.(Fig. 14.1)

Fig. 14.1

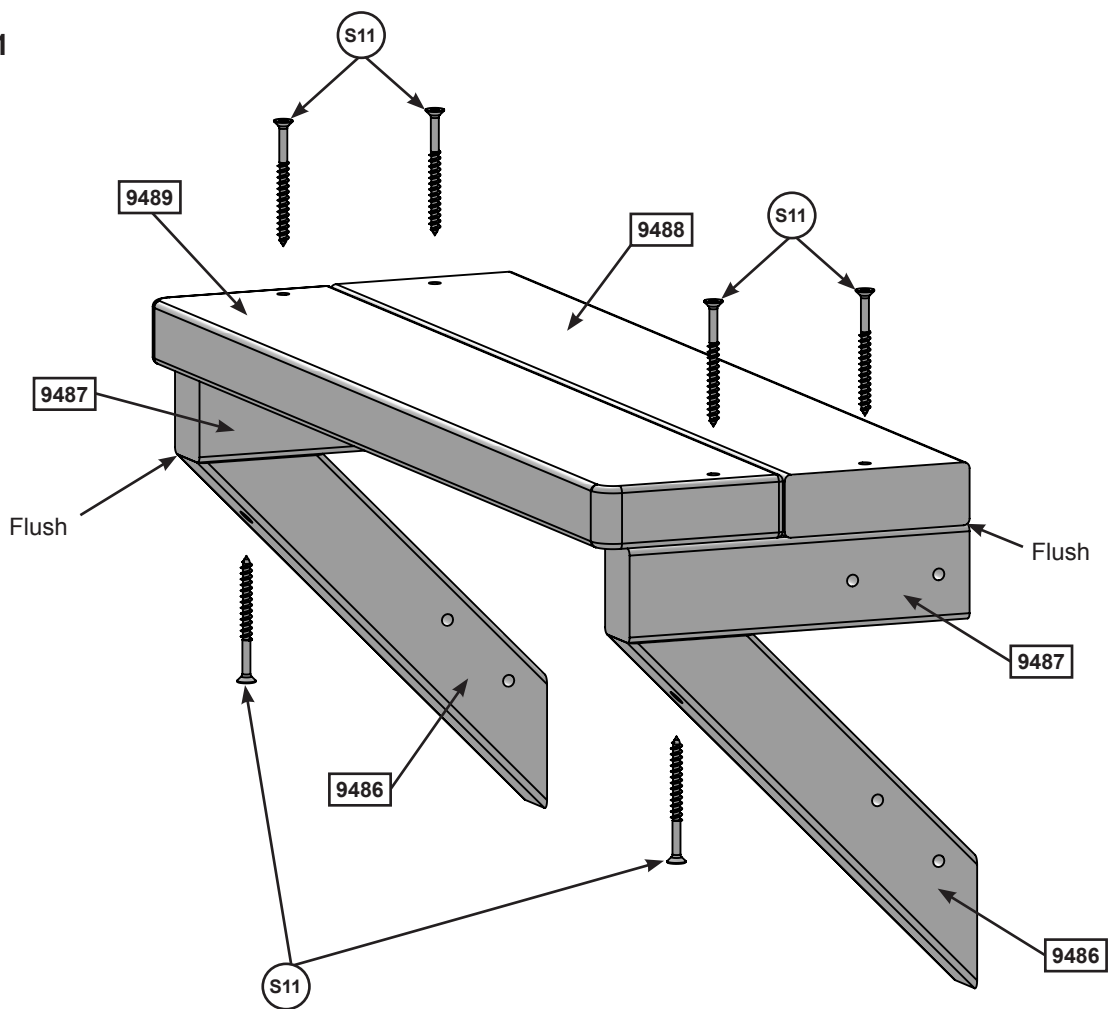

Wood Parts

- 2 x 9486 Chair Gusset 1 x 1-1/2 x 8-5/16"
- 2 x 9487 Chair Gusset A 1 x 1-1/2 x 5-3/4"
- 1 x 9488 Chair Top 1 x 3-1/8 x 18-9/16"
- 1 x 9489 Chair Top A 1 x 3-1/8 x 18-5/8"

Hardware

- 6 x S11 #8 x 2" Wood Screw

Step 15: Attach Chair Assembly



A: Measure 10-3/4" (27.3 cm) up from the top of the (9491) Ground Brace to the bottom of (9488) Chair Top. (Fig. 15.2). Install Bench Assembly to the inside of the fort and the (9494) Crowsnest Upright as shown in (fig. 15.1 & 15.2) making sure that it is flush to the edge of the frame. Attach using 4 (S11) #8 x 2" Wood Screws per side.

Fig. 15.1

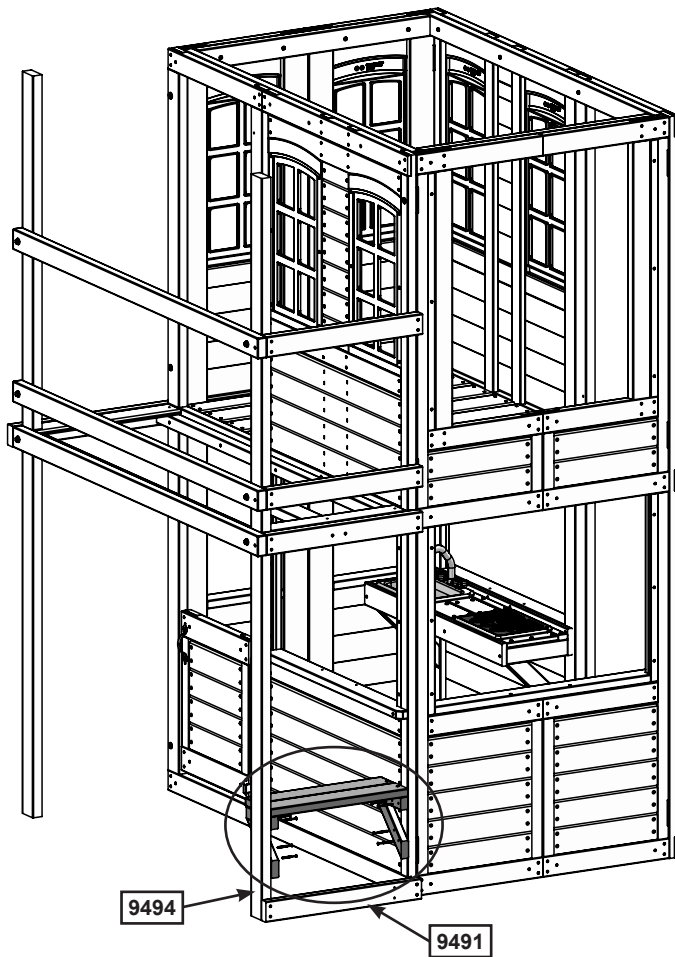
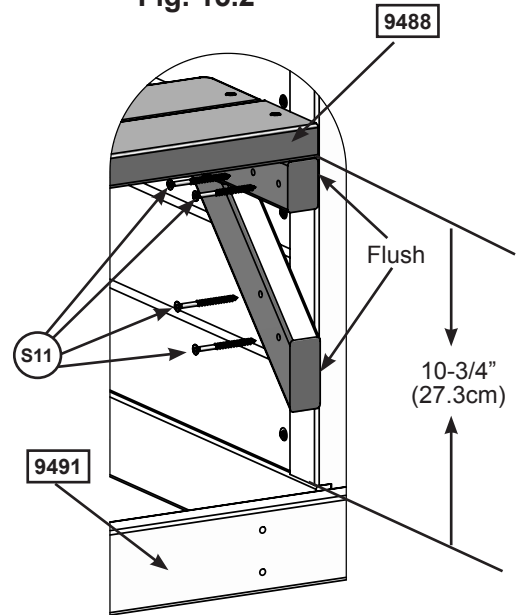

Fig. 15.2



Hardware

8 x (S11) #8 x 2" Wood Screw

Step 16: Attach Crowsnest Gusset

A: On the underside of one end of the deck assembly, place 1 (9495) Crowsnest Gusset as shown in (fig.16.2). One end of the Gusset should be flat against (9465) Side Joist-1 and the other end should be flush with the front edge of (9494) Crowsnest Upright. Attach using 2 (S3) #8 x 2-1/2" Wood Screws. (fig.16.1 and 16.2)

B: Repeat to install a second (9495) Crowsnest Gusset on the opposite side. (fig.16.1 and 16.2)

Fig. 16.1

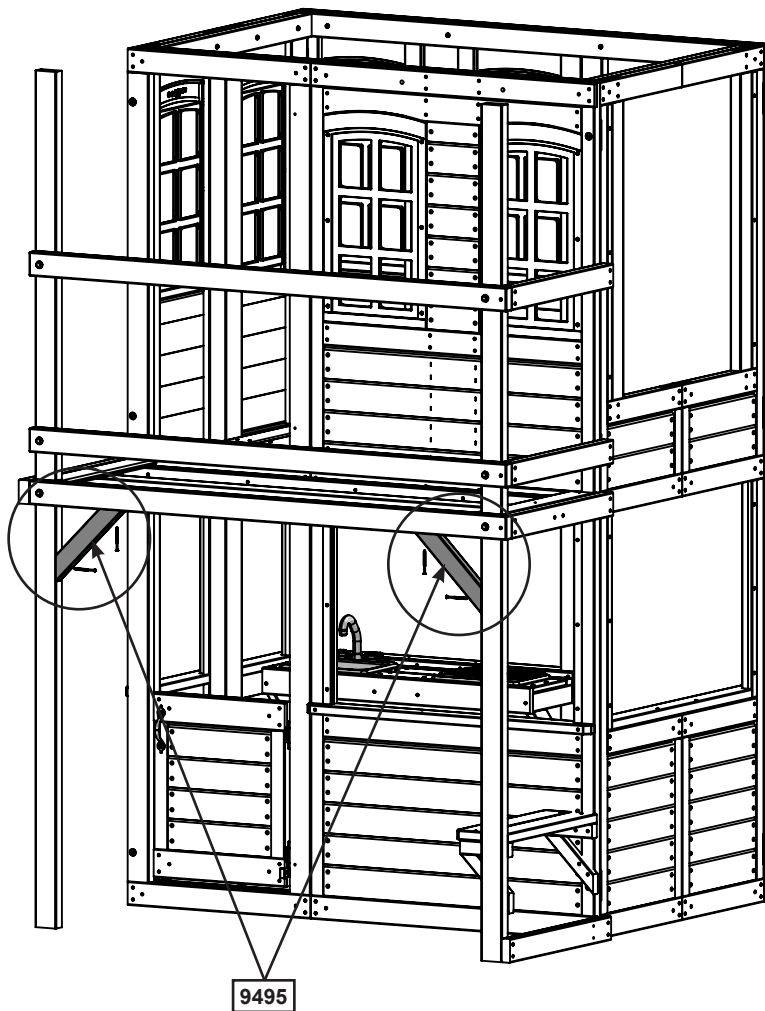
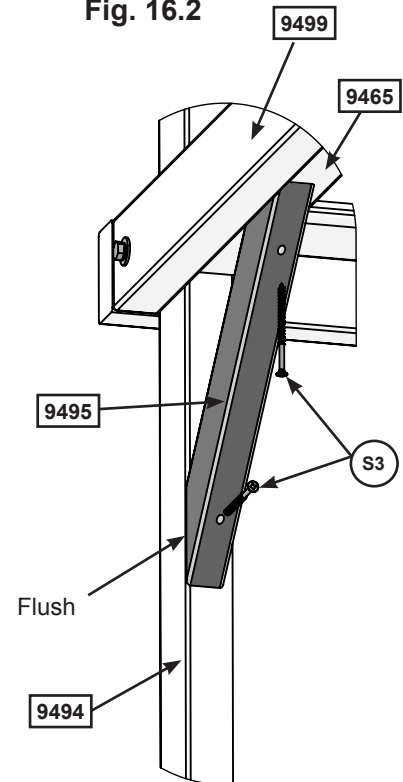

Fig. 16.2



Wood Parts

2 x 9495 Crowsnest Gusset 1 x 2 x 12"

Hardware

4 x S3 #8 x 2-1/2" Wood Screw

Step 17: Access Ladder Assembly Part 1



- A:** Place (9478) Left Rail on one side of 4 (9480) Ladder Gap and (9479) Right Access on the other side with the grooves facing in. (fig. 17.1)
- B:** Fit each (9480) Ladder Gap into grooves on both (9478) and (9479) Access rails, making sure the top edge of the (9480) Ladder Gap are flush to the front of the Access rails. (fig.17.1 and 17.2 & 17.3)
- C:** Pre-drill pilot holes with a 1/8" drill bit and attach rails and Ladder Gap together using 4 (S3) #8 x 2-1/2" Wood Screws per Ladder Gap. (fig.17.1 and 17.2)

Fig. 17.1

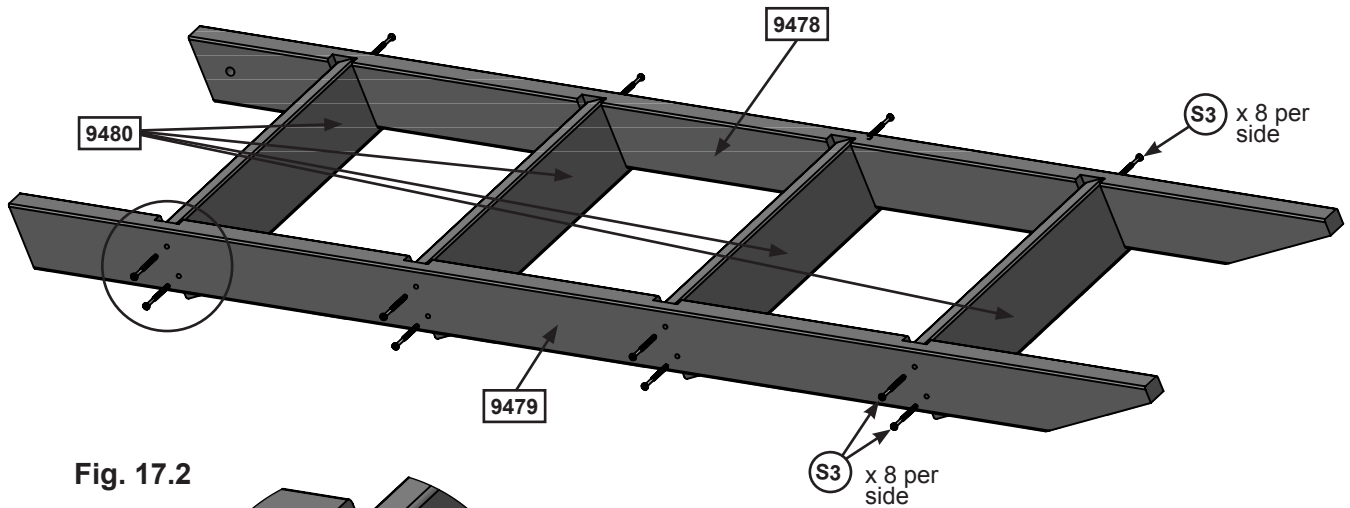

Fig. 17.2

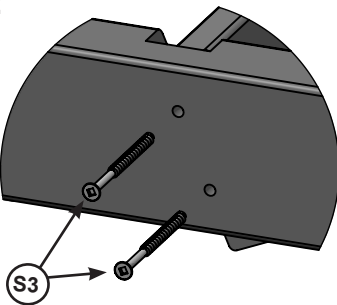
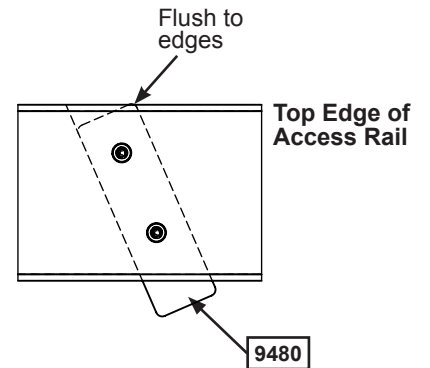

Fig. 17.3
End View



Wood Parts

- 1 x 9478 Left Rail 1-3/8 x 2-3/4 x 51-17/32"
- 1 x 9479 Right Rail 1-3/8 x 2-3/4 x 51-17/32"
- 4 x 9480 Ladder Gap 1 x 3-1/4 x 19-3/8"

Hardware

- 16 x S3 #8 x 2-1/2" Wood Screw

Step 17: Access Ladder Assembly Part 2



D: Place 1 (9481) RW-AL Support on the back of the ladder so that it sits flush to the top of the angle cut as shown in fig. 17.5. Attach using 4 (S20) #8 x 1-3/8" Wood Screws. (Fig. 17.4 & 17.5)

E: Flush to the top and edges of the (9478) and (9479) Rails, attach (9482) RW-AL A using 4 (S20) #8 x 1-3/8" Wood Screws. (Fig. 17.4 & 17.5)

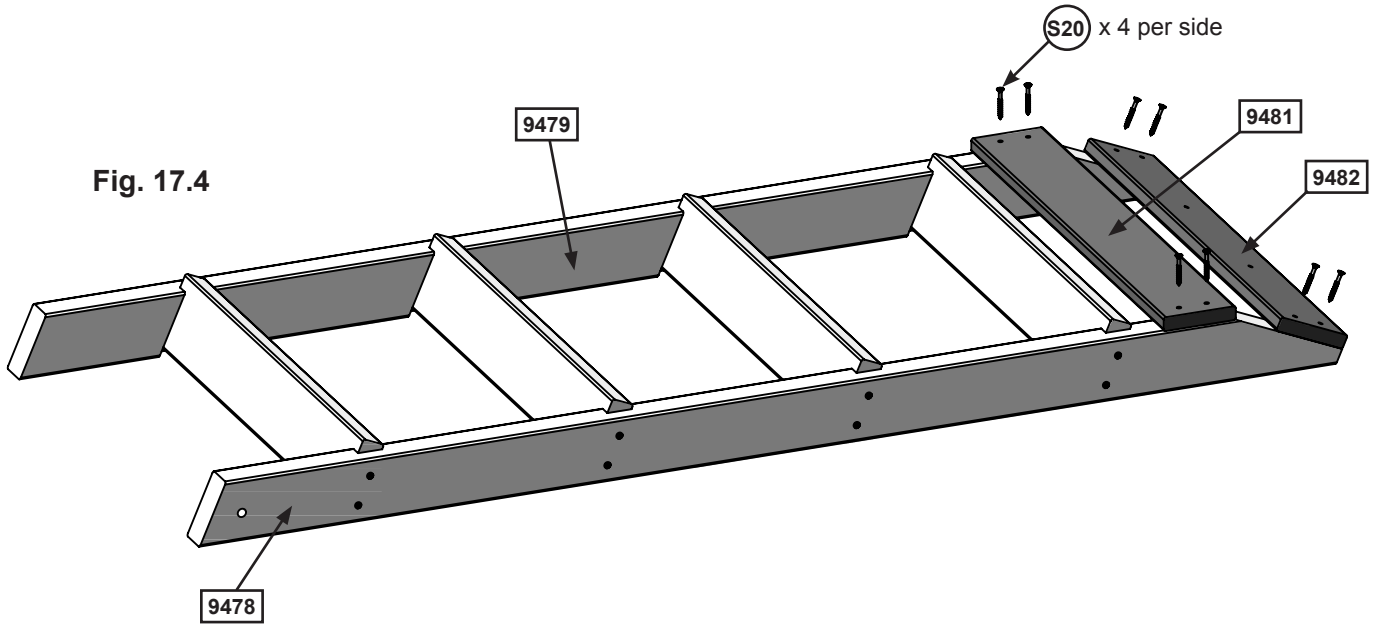

Fig. 17.4

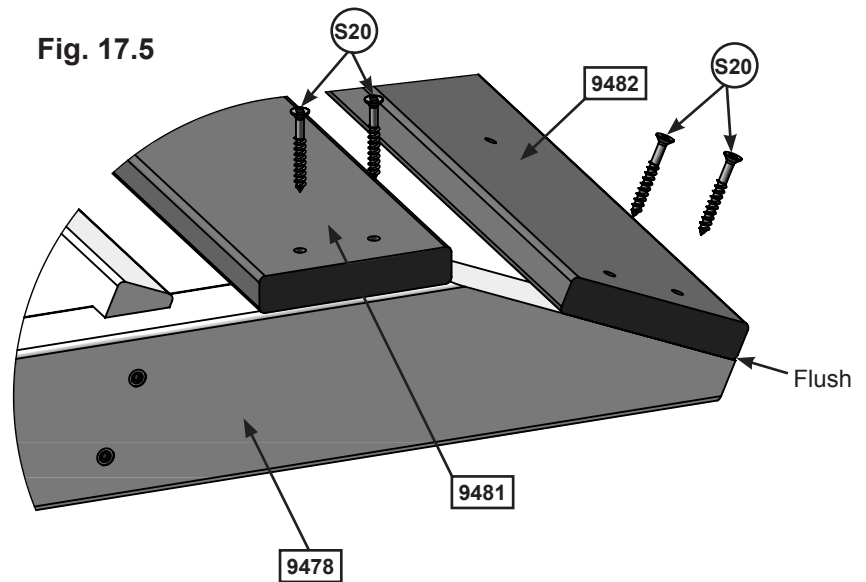

Fig. 17.5

Wood Parts

- 1 x 9481 RW-AL Support 5/8 x 3-1/4 x 20-15/16"
- 1 x 9482 RW-AL A Support 5/8 x 3-1/4 x 20-15/16"

Hardware

- 8 x S20 #8 x 1-3/8" Wood Screw

Step 18: Attach Access Ladder Part 1

A: Place Ladder Assembly in the back opening of (9264) Folding Panel Assembly Left A. Make sure that the ladder is flush to the top of the floor boards and the outside edge of the panel, then attach using 2 (S20) #8 x 1- 3/8" Wood Screws.(Fig.18.1 & 18.2)

Fig. 18.1

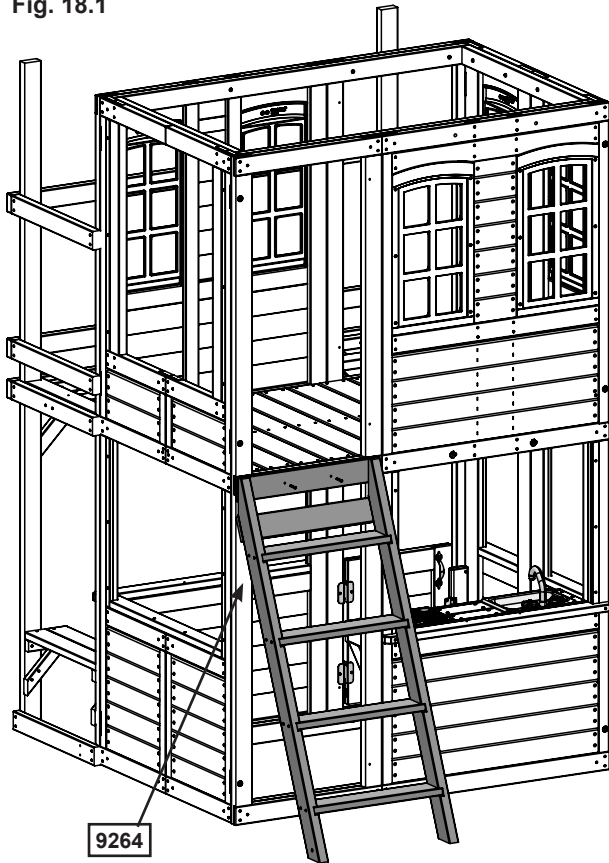
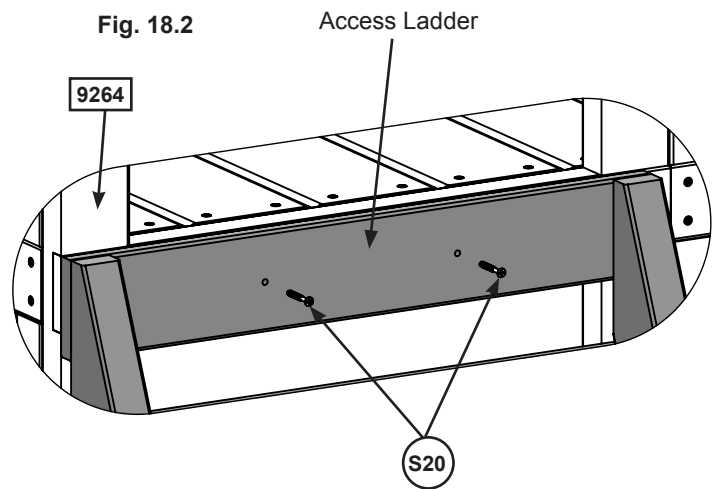



Fig. 18.2



Hardware

2 x  #8 x 1-3/8" Wood Screw

Step 18: Attach Access Ladder Part 2

B: Place (9477) Supporting Diagonal so that the angled end is flush with the front edge of (9478) Left Rail and attach using 1 (H3) 1/4 x 2-1/4" Hex Bolt (with lock washer, flat washer and t-nut). Attach opposite end of (9477) Supporting Diagonal to the fort using 3 (S11) #8 x 2" Wood Screws. (fig. 18.3)

Fig. 18.3

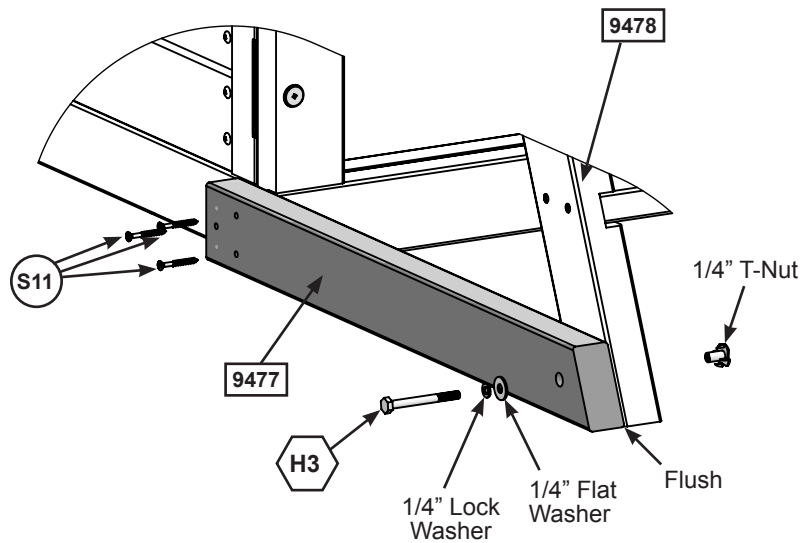

Wood Parts

1 x 9477 Supporting Diagonal 1 x 3-1/4 x 24-5/16"

Hardware

3 x S11 #8 x 2" Wood Screw
 1 x H3 1/4 x 2-1/4" Hex Bolt
 (1/4" lock washer, 1/4" flat washer, 1/4" t-nut)

Step 19: Rockwall Assembly



A: Lay 2 (9484) Rails down, side by side with angled edges facing down. (Fig. 19.1)

B: Place (9522) Board Rock on the top of each (9484) Rail as shown in fig. 19.1. **Do not attach.** This board is to be used as a guide only and will be attached in a later step. Make sure (9522) Board Rock is flush to the outside and top edges of each (9484).

C: Taking note of the hole orientation, place 1 (9485) Board Rock at the bottom of the (9484) Rails, making sure that it is flush to the edges and the bottom. Attach using 4 (S20) #8 x 1-3/8" Wood Screws. (Fig. 19.1)

D: In between the top and bottom board, evenly space the remaining (9485) Board Rocks, making sure that the pre-drilled rock holes are at opposite ends on each board. This will prevent rocks from forming a straight line. Attach using 4 (S20) #8 x 1-3/8" Wood Screws per board. (Fig. 19.1)

E: Alternating colors and shapes, place 1 rock on each (9485) Board Rock and attach using 1 (PB2) 1/4 x 1-1/4" Pan Bolt (with lock washer, flat washer and barrel nut) and 1 (S10) #8 x 1" Pan Screw per rock. The Screw must be in the hole directly under the Pan Bolt, this will stop the rock from spinning. (Fig. 19.2 & 19.3 & 19.4 & 19.5).

Fig. 19.5
Note hole orientation

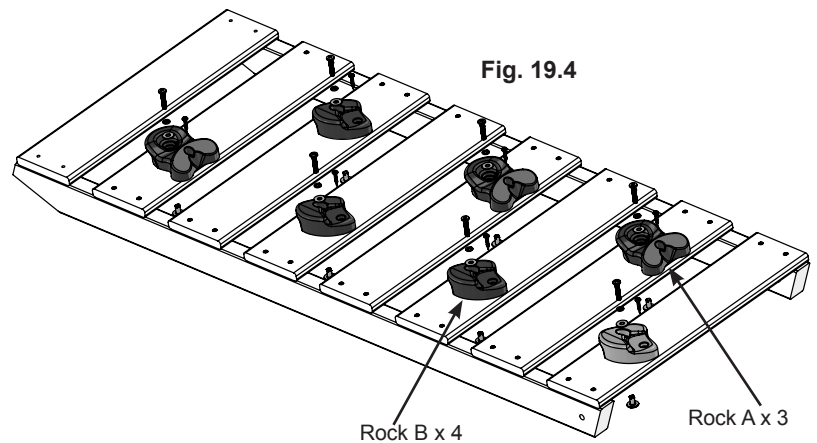
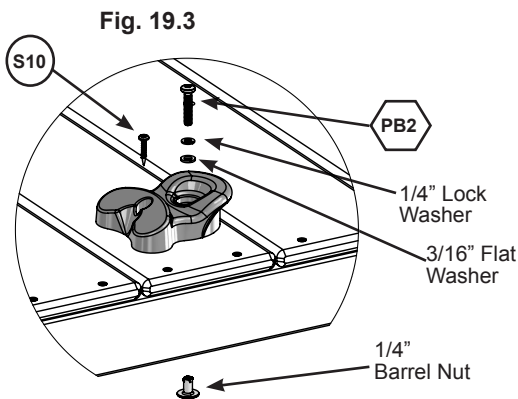
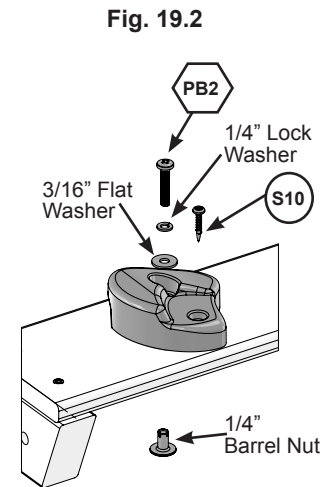
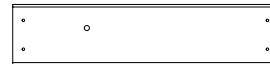
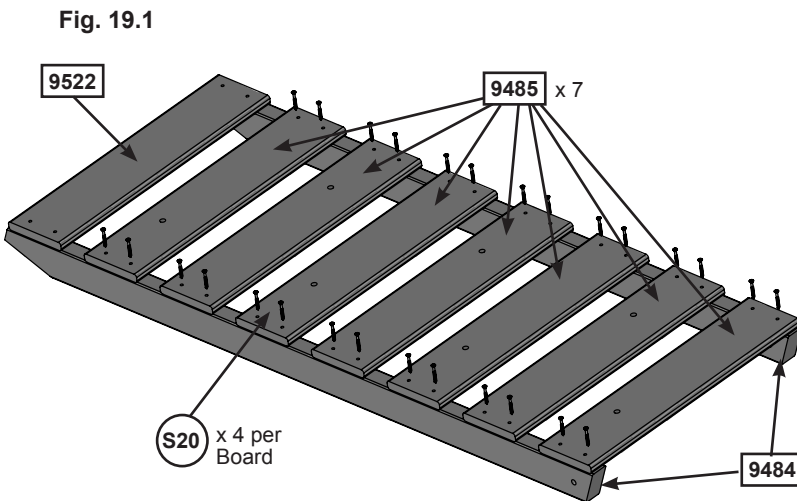

Wood Parts

- 1 x 9522 Board Rock 5/8 x 4-1/2 x 19-11/16"
- 7 x 9485 Board Rock 5/8 x 4-1/2 x 19-11/16"
- 2 x 9484 Rail 1-1/4 x 2-1/2 x 50-45/64"

Hardware

- 7 x PB2 1/4 x 1-1/4 Pan Bolt (1/4" lock washer, 3/16" flat washer & 1/4" barrel nut)
- 7 x S10 #8 x 1" Pan Screw
- 28 x S20 #8 x 1-3/8" Wood Screw

Other Parts

- 3 x Rock A
- 4 x Rock B

Step 20: Attach Rockwall Part 1

A: Place (9490) Ground Brace across the bottom left opening of the Deck Assembly so that it's flush to the front of (9494) Crowsnest Upright. Attach to the fort using 4 (S3) #8 x 2- 1/2" Wood Screws. (Fig. 20.1 & 20.2)

Fig. 20.1

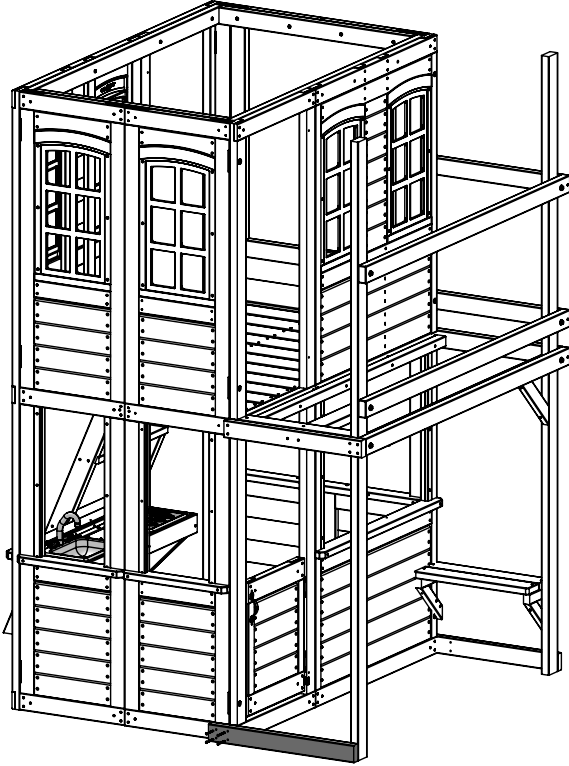
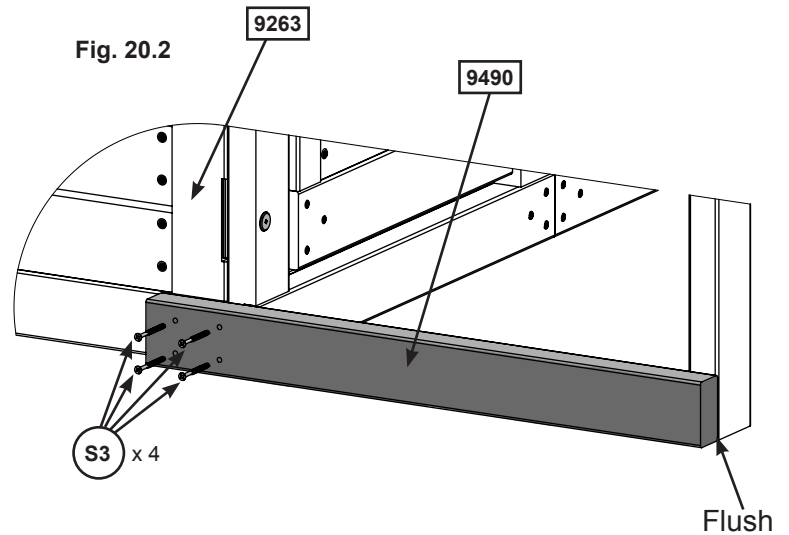

Fig. 20.2



Wood Parts

1 x 9490 Ground Brace 1-1/4 x 2-1/2 x 23-9/16"

Hardware

4 x S3 #8 x 2-1/2" Wood Screw

Step 20: Attach Rockwall Part 2



B: Place Access Ladder/Rockwall and 1-1/4" from the end into the opening on the left end of the deck assembly. Make sure it's flush to the top of the (9498) Crowsnest Short L and attach using 2 (S11) #8 x 2" Wood Screws. (fig. 20.4)

C: Place (9522) Board Rock in the opening at the top of the ladder, making sure it's flush to the edges and the top. Attach using 4 (S20) #8 x 1-3/8" Wood Screws. (fig. 20.3)

D: Place (9483) Diagonal so that the angled end is flush with the front edge of the outside (9484) Rail and attach using 1 (H3) 1/4 x 2-1/4" Hex Bolt (with lock washer, flat washer and t-nut). Attach opposite end of (9483) Diagonal to (9494) Crowsnest Upright and (9490) Ground Brace using 4 (S11) #8 x 2" Wood Screws.(fig. 20.5)

Fig. 20.3

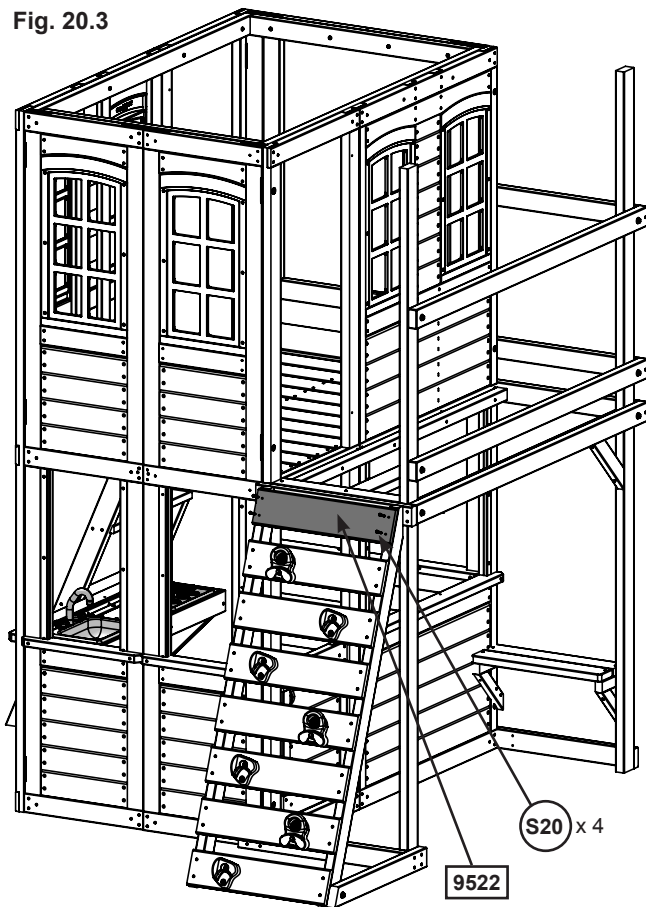

Fig. 20.4

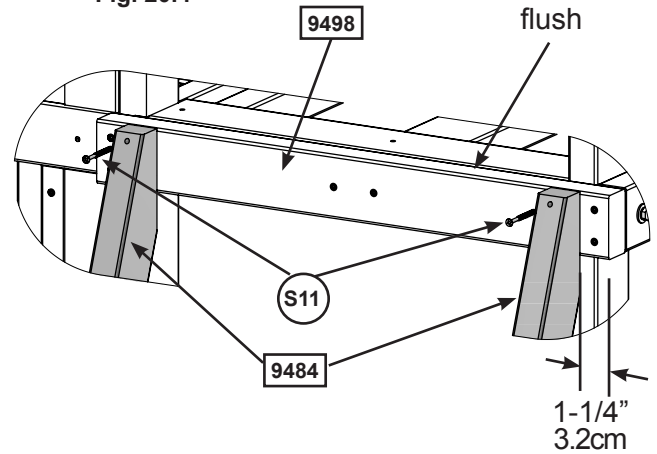
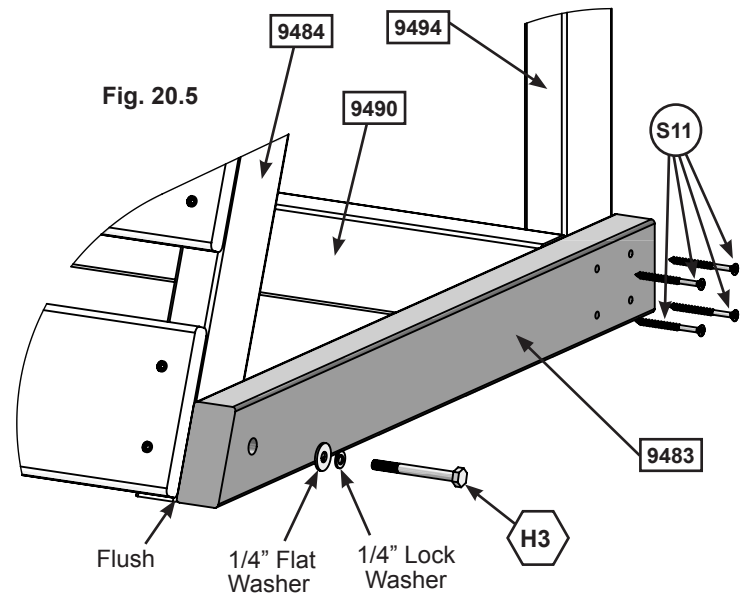

Fig. 20.5



Wood Parts

1 x 9483 Diagonal 1 x 3-1/8 x 22-49/64"

Hardware

- 6 x (S11) #8 x 2" Wood Screw
- 1 x (H3) 1/4 x 2-1/2" Hex Bolt (1/4" lock washer, 1/4" flat washer, 1/4" t-nut)
- 4 x (S20) #8 x 1-3/8" Wood Screw

Step 21: Install Crownsnest Floor Boards

A: Evenly space 11 (9467) Floor Board Shorts between the 2 end boards and attach using 6 (S20) #8 x 1-3/8" Wood Screws per board.(Fig. 21.1)

Fig. 21.1

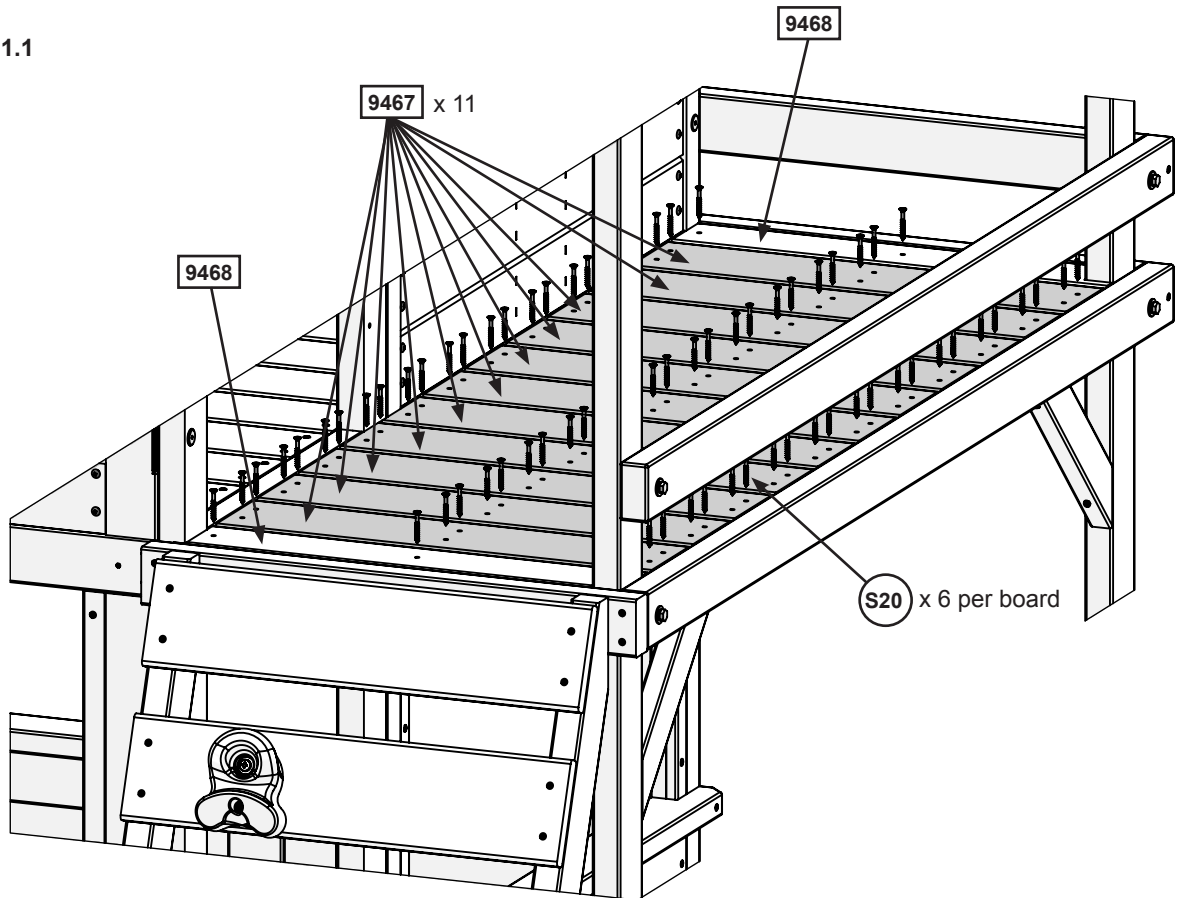

Wood Parts

11 x **9467** Floor Board Short 5/8 x 4-1/2 x 19-39/64"

Hardware

66 x **(S20)** #8 x 1-3/8" Wood Screw

Step 22: Install Cedar Walls



A: From inside the deck assembly, on the right end, evenly space 3 (9500) Cedar Wall boards between the (9496) Crowsnest Shorts making sure that the beveled edge is to the inside. Attach using 4 (S20) #8 x 1-3/8" Wood Screws per board. (Fig. 22.1 & 22.2)

B: Center 1 (9500) Cedar Wall in the front wall opening between the 2 (9494) Crowsnest Uprights. Attach (9500) Cedar Wall to each (9499A) Crowsnest Bottom using 4 (S20) #8 x 1-3/8 Wood Screws.(Fig. 22.1 & 22.2)

C: Install 4 (9500) Cedar Walls on each side of the center board, making sure that there is a 3" space between each board. Attach using 4 (S20) #8 x 1-3/8" Wood Screws per board. (Fig. 22.3 & 22.2 & 22.4)

Fig. 22.1

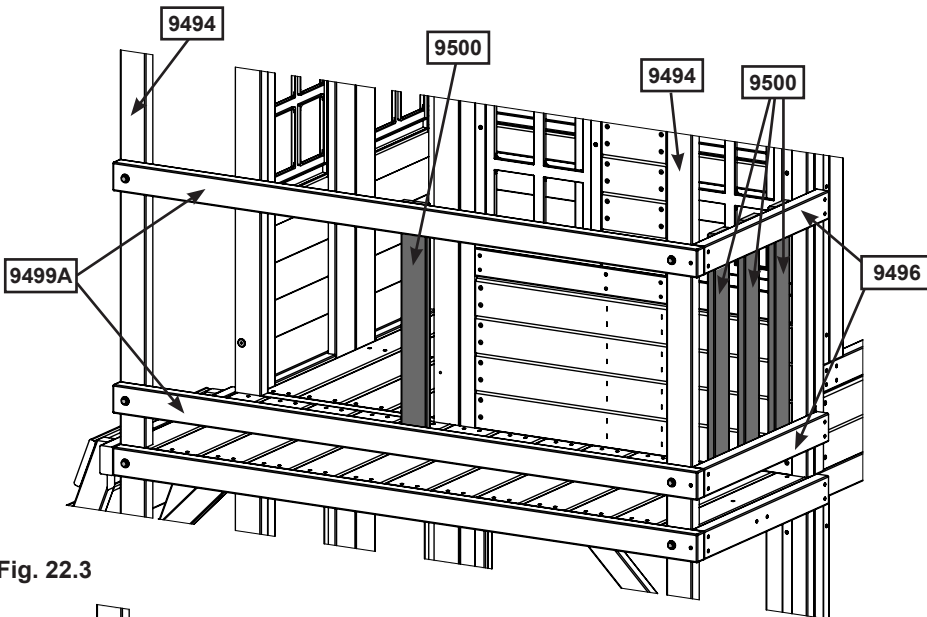

Fig. 22.4
3" (7.62cm)

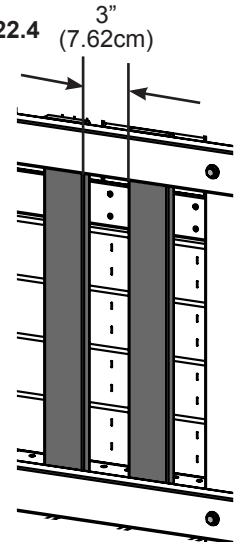

Fig. 22.3

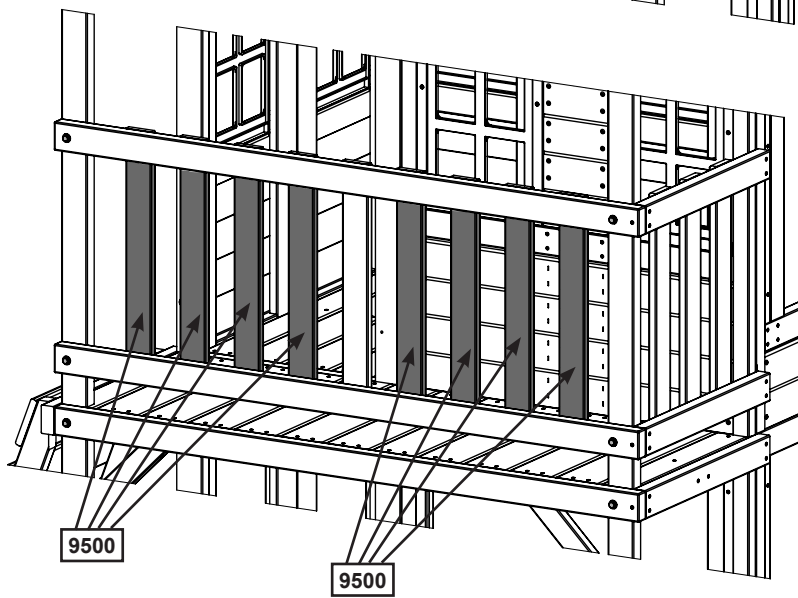
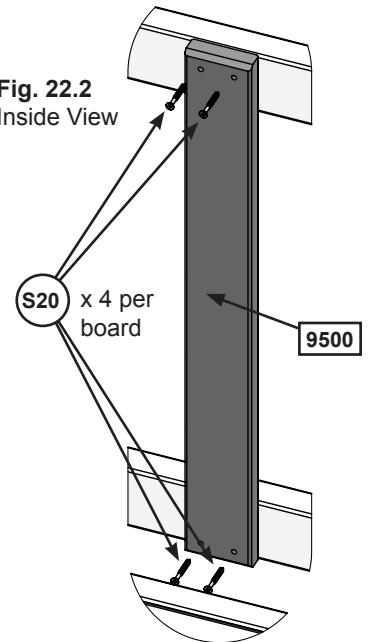

Fig. 22.2
Inside View



Wood Parts

12 x 9500 Cedar Wall 3/4 x 2-1/2 x 22"

Hardware

48 x S20 #8 x 1-3/8" Wood Screw

Step 23: Attach Flower Boxes

A: Attach Flower Boxes in the locations shown in 23.1 using 2 (S0) #8 x 7/8" Truss Head Screws per box.

Fig. 23.1

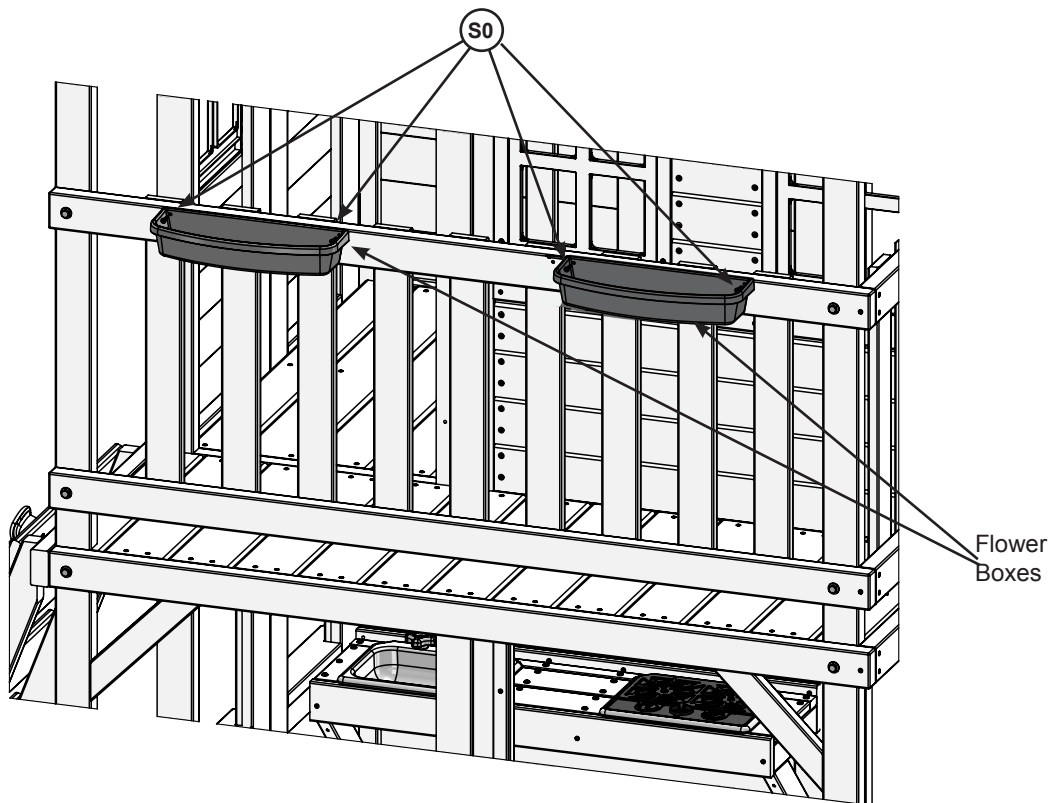
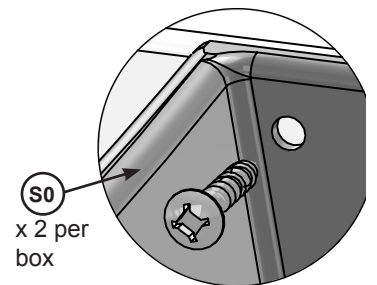



Fig. 23.2



Hardware

4 x  #8 x 7/8" Truss Head Screw

Other Parts

2 x Flower Box

Step 24: Attach Hand Grips to Fort



Note: Pre-drill all holes using a 1/8" drill bit before installing the Wafer Lags

A: Measure 6" up from the top of the Rockwall and center 1 Hand Grip on each side. Pre-drill, then attach Hand Grips with 2 (WL3) 1/4 x 1-3/8" Wafer Lags (with flat washer) per Hand Grip. (fig. 24.1 and 24.3)

B: Measure 6" up from the Access Ladder and place 2 more Hand Grips so they are flush to the edges of the opening. Pre-drill, then attach using 2 (WL3) 1/4 x 1-3/8" Wafer Lags (with flat washer) per Hand Grip. (fig. 24.2 and 24.3)

Fig. 24.1

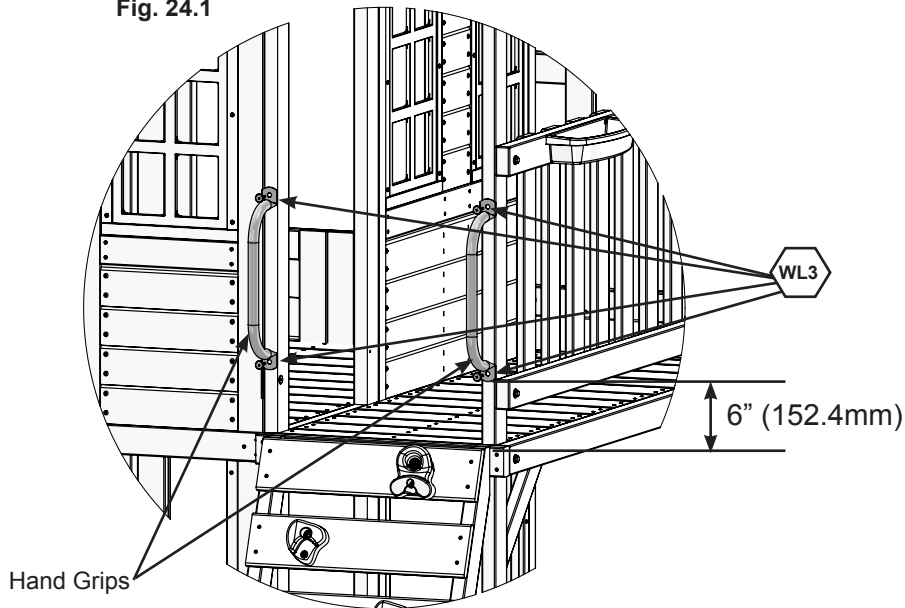

Fig. 24.3

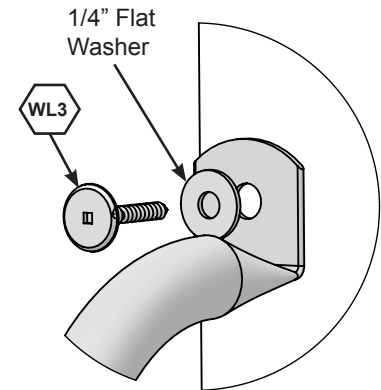
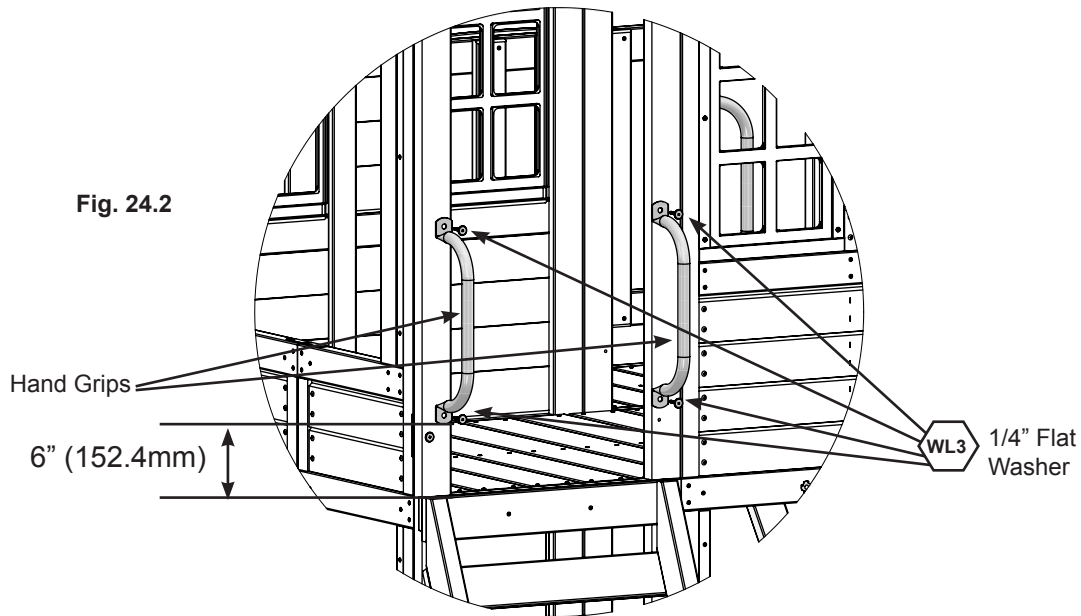

Fig. 24.2



Hardware

8 x  1/4 x 1-3/8" Wafer Lag (1/4" Flat Washer)

Other Parts

4 x Hand Grips

Step 25: Roof Support Assembly Part 1



A: Place (9501) Top Swing flat on the ground with the angles facing up. The sharper angle should be on the right end. Place (9503) Roof Support as shown in fig. 25.1 making sure that it's flush with the edge of (9501) Top Swing.

B: Place (9502) Support Upright as shown in fig. 25.1, making sure that it's flush with the end of (9503) Roof Support and centered over the pre-drilled holes in (9501) Top Swing. Check to ensure that the assembly is square then attach boards using 4 (S4) #8 x 3" Wood Screws.

C: Repeat steps A and B to create a second assembly.

Fig. 25.1

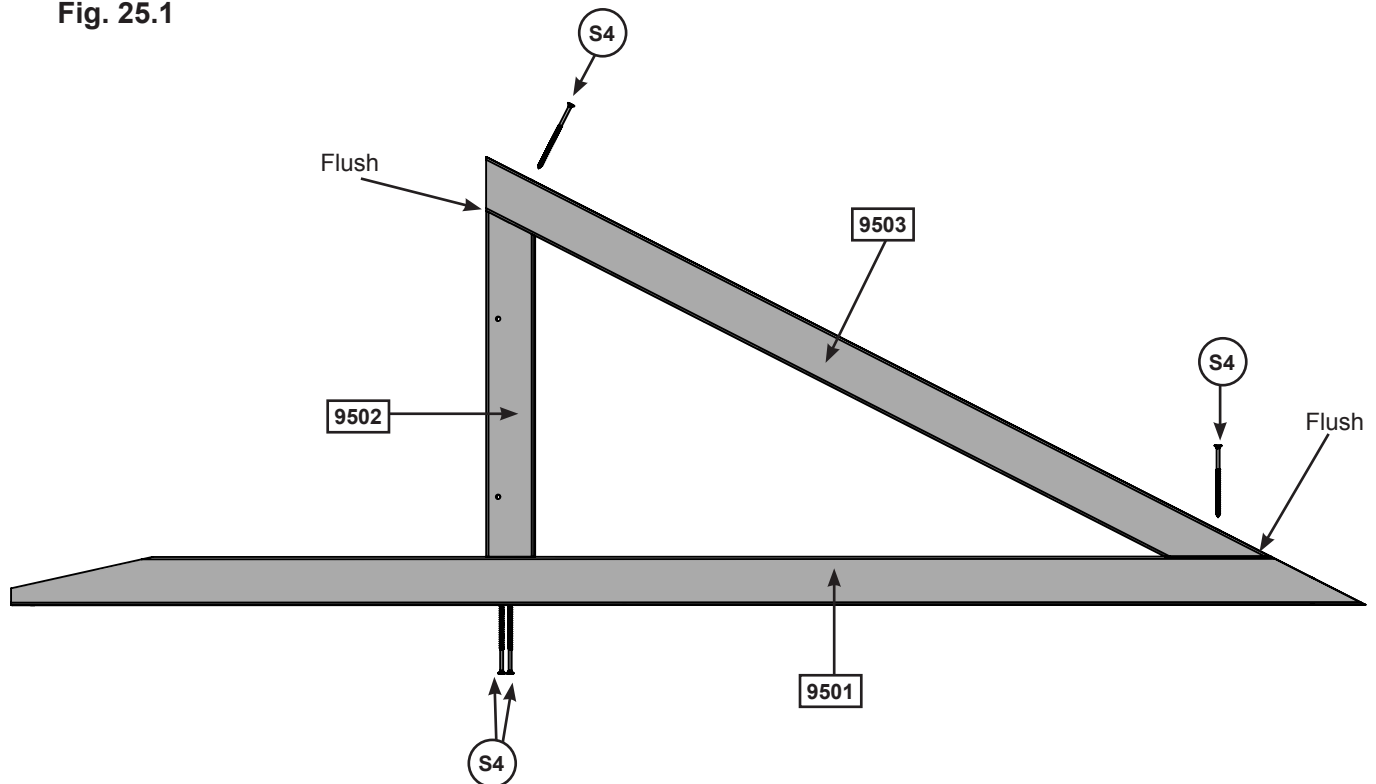

Wood Parts

- 2 x 9501 Top Swing 1-1/4 x 2 x 56-7/16"
- 2 x 9502 Support Upright 1-1/4 x 2 x 10-39/64"
- 2 x 9503 Roof Support 1-1/4 x 2 x 34-1/16"

Hardware

- 8 x S4 #8 x 3" Wood Screw

Step 25: Roof Support Assembly Part 2

A: Center 1 Triangle Canopy over the inside of each Roof Support Assembly. Make sure canopy is pulled tight during the installation. Attach using 10 (S5) #8 x 1/2" Pan Screws (#8 flat washer) per canopy. (Fig. 25.2)

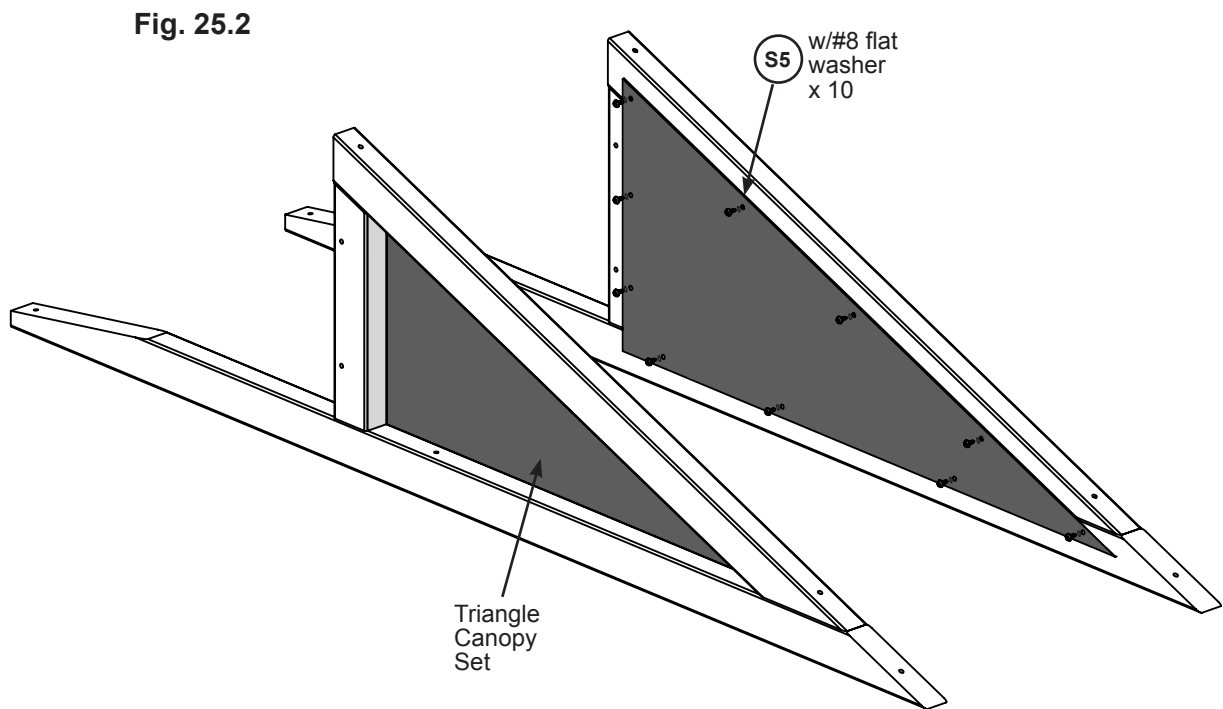

Hardware

20 x (S5) #8 x 1/2" Pan Screw (#8 flat washer)

Other Parts

1 x Cozy Escape
Triangle Canopy Set

Step 26: Attach Roof Support Assembly

A: Place 1 Roof Support Assembly across each end of the fort as shown in fig. 26.1. Make sure that assemblies are flush to the back and end wall panels and to the outside edge of the (9494) Crowsnest Uprights. Attach using 3 (S4) #8 x 3" Wood Screws per side. (fig. 26.1)

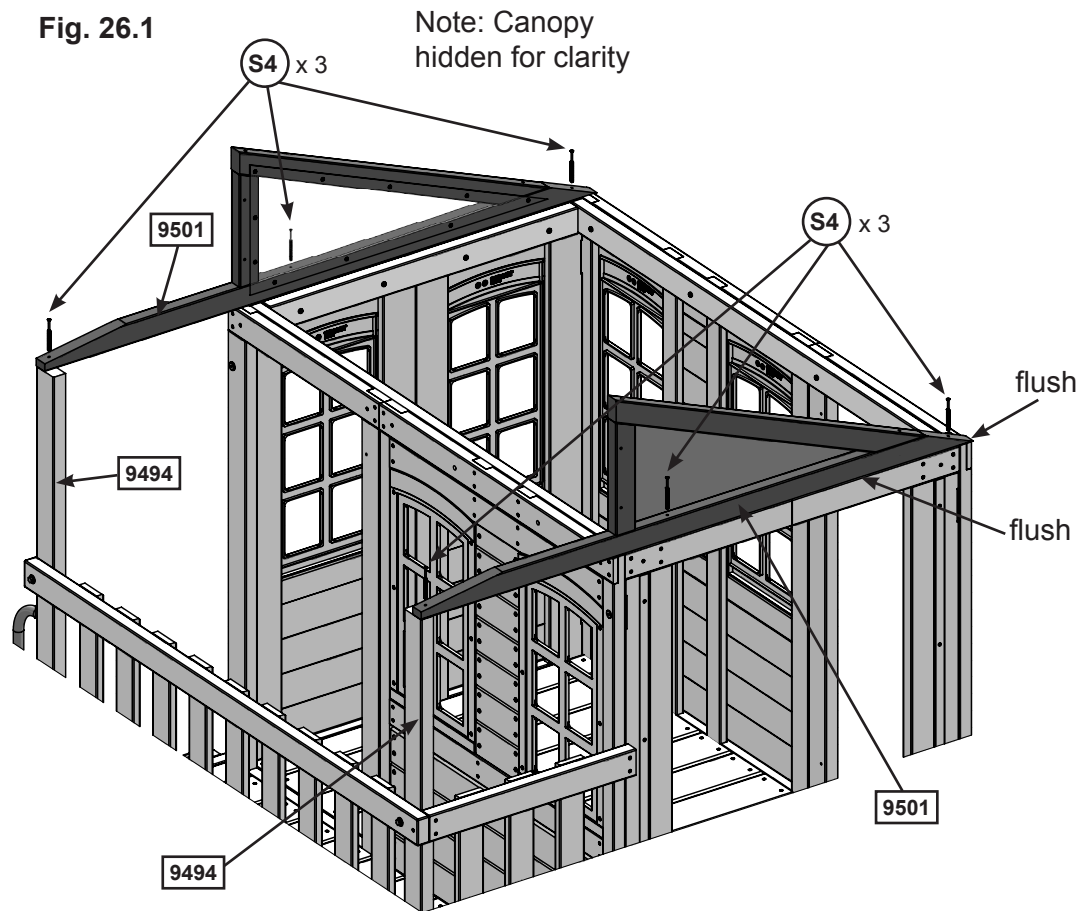

Hardware

6 x  #8 x 3" Wood Screw

Step 27: Install Window Panel

A: Making sure that the windows are at the top, place (9261) Window Panel over the front wall panel so that it fits between the 2 Roof Support Assemblies. Attach using 4 (S11) #8 x 2" Wood Screws. (fig. 27.1)

Fig. 27.1

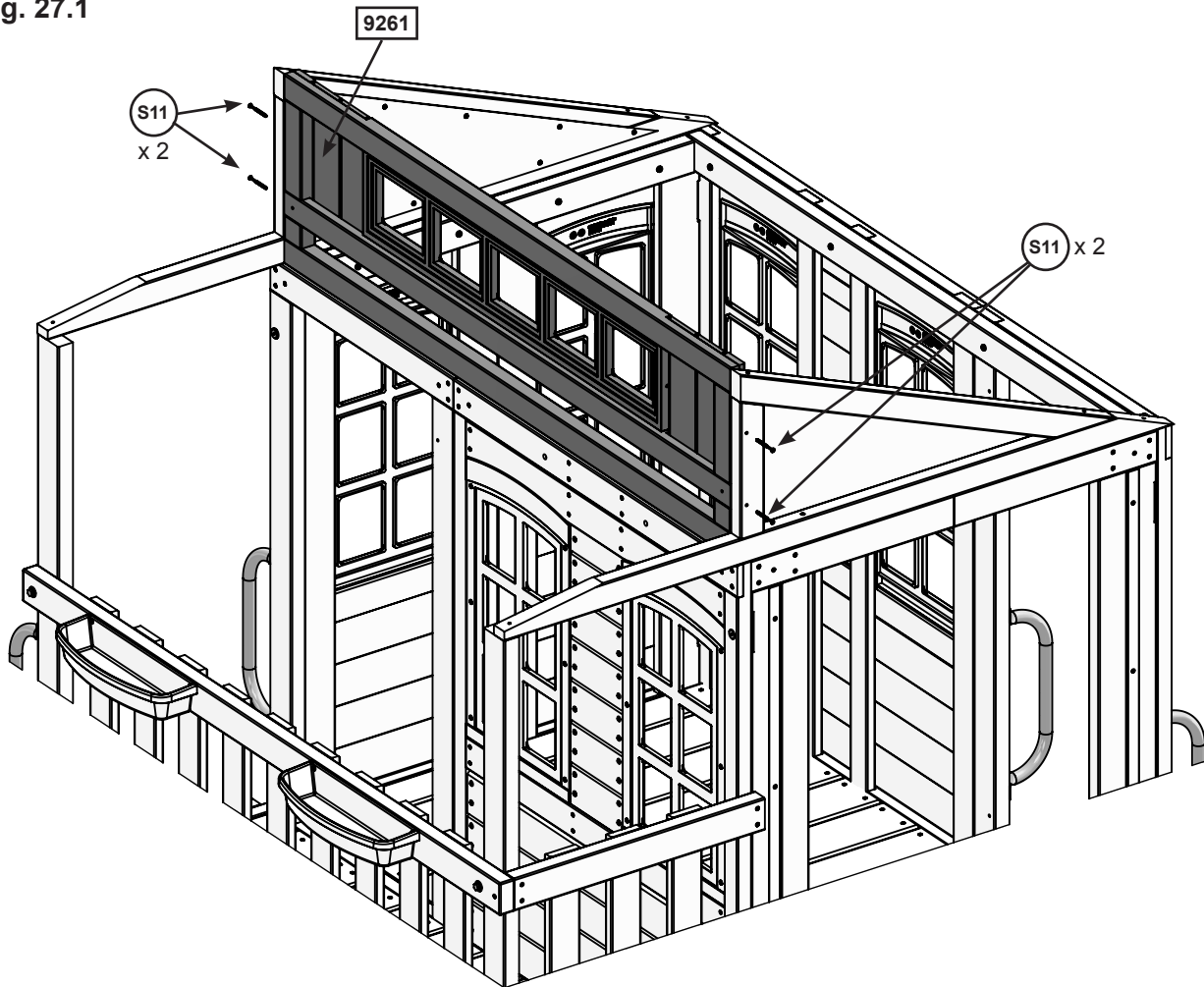

Wood Parts

1 x 9261 Window Panel 1-1/4 x 14-49/64 x 53-5/8"

Hardware

4 x S11 #8 x 2" Wood Screw

Step 28: Large Roof Panel Assembly Part 1

A: Lay flat 3 (9511) Roof Bottoms. Place 1 (9504) Roof Sleeper Left along the top of the Roof Bottoms, taking note of the hole orientation. Attach (9504) Roof Sleeper to each (9511) Roof Bottom using 2 (S11) #8 x 2" Wood Screws. (fig. 28.1 & 28.2)

B: Place 1 (9519) Roof Sleeper Right along the bottom of the (9511) Roof Bottoms being careful to note the hole orientation. Attach (9519) Roof Sleeper Right to each (9511) Roof Bottoms using 2 (S11) #8 x 2" Wood Screws. (fig. 28.1 & 28.2)

C: Fit (9506) Roof Bottom A between (9519) Roof Sleeper Right and (9504) Roof Sleeper Left as shown in (fig. 28.1) Attach using 2 (S11) #8 x 2" Wood Screws per end.

D: Lay (9520) Roof Cover flat over the (9506) Roof Bottom A, making sure that it's flush with the edges of the assembly. Attach using 6 (S20) #8 x 1-3/8" Wood Screws. (fig. 28.3 & 28.4)

Fig. 28.1

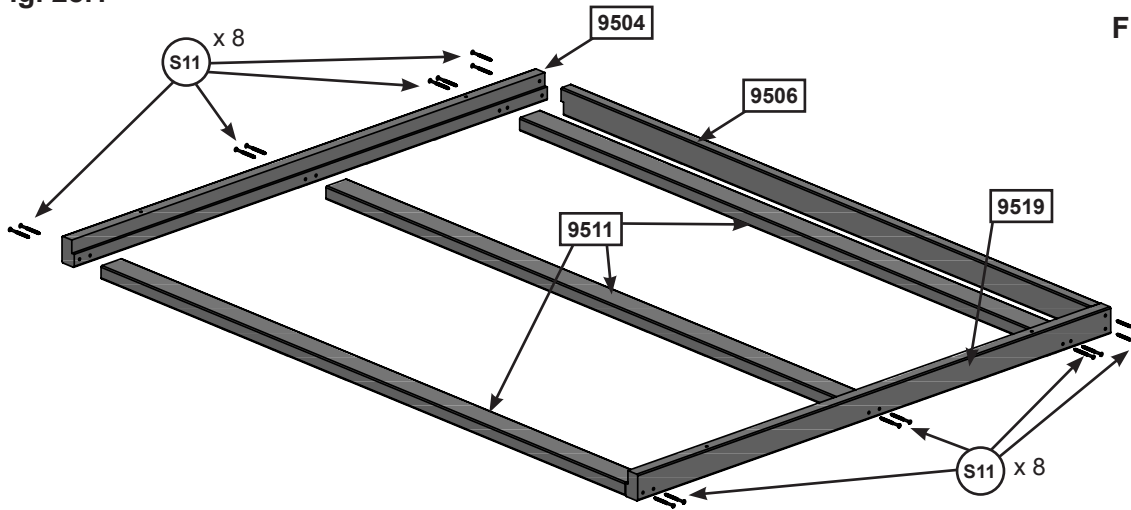

Fig. 28.2

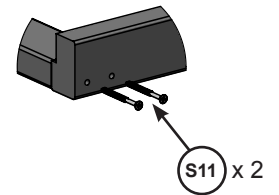

Fig. 28.3

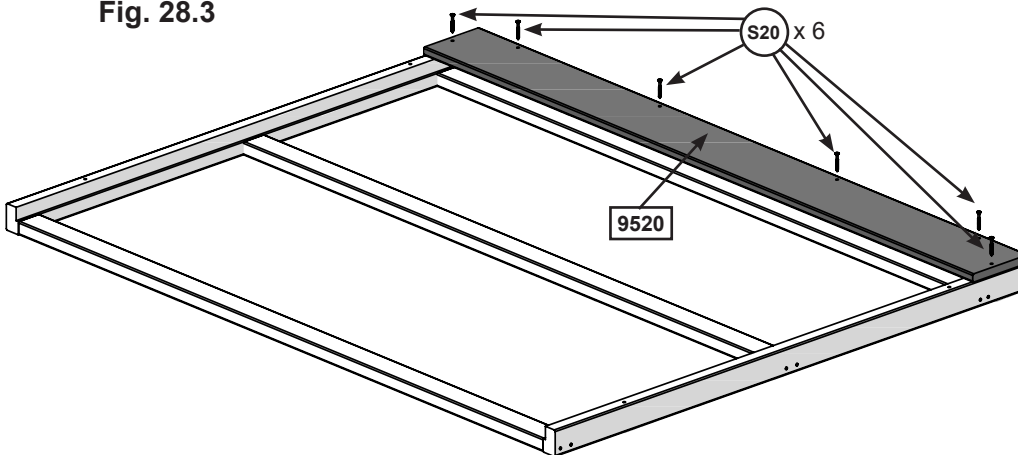
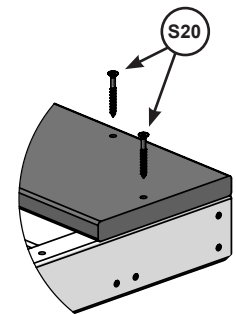

Fig. 28.4



Wood Parts

- 1 x 9504 Roof Sleeper left 1-1/4 x 2 x 44-3/4"
- 1 x 9506 Roof Bottom A 1 x 2 x 54-1/8"
- 3 x 9511 Roof Bottom 1 x 2 x 53-5/8"
- 1 x 9519 Roof Sleeper Right 1-1/4 x 2 x 44-3/4"
- 1 x 9520 Roof Cover 5/8 x 5-1/4 x 56-1/8"

Hardware

- 16 x S11 #8 x 2" Wood Screw
- 6 x S20 #8 x 1-3/8" Wood Screw

Step 28: Large Roof Panel Assembly Part 2



Important: Do not over tighten hardware

E: Slide 1124 x 1067mm Roof Panel under (9520) Roof Cover so that it's tight to (9504) Roof Sleeper Left. (Fig. 28.5 & 28.6 & 28.9)

F: Place 370 x 1067mm Roof Panel in the remaining opening, under (9520) Roof Cover. The inside edge should overlap the Large Roof panel with the pre-drilled holes lining up. (Fig. 28.5 & 28.6 & 28.9)

G: Pre-drill all holes using a 1/8" drill bit, place Special Weather Cap brackets over each hole in the Roof Panels then attach using 1 (S2) #8 x 1-1/2" Wood Screw per bracket. Press the Special Weather Cap over the top of each screw.(Fig. 28.7 & 28.8 & 28.9)

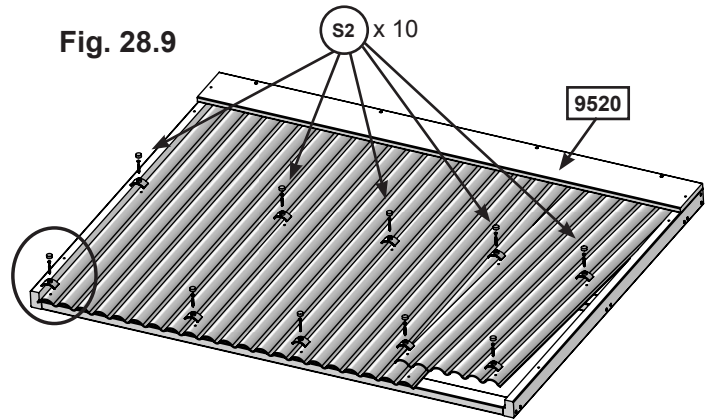
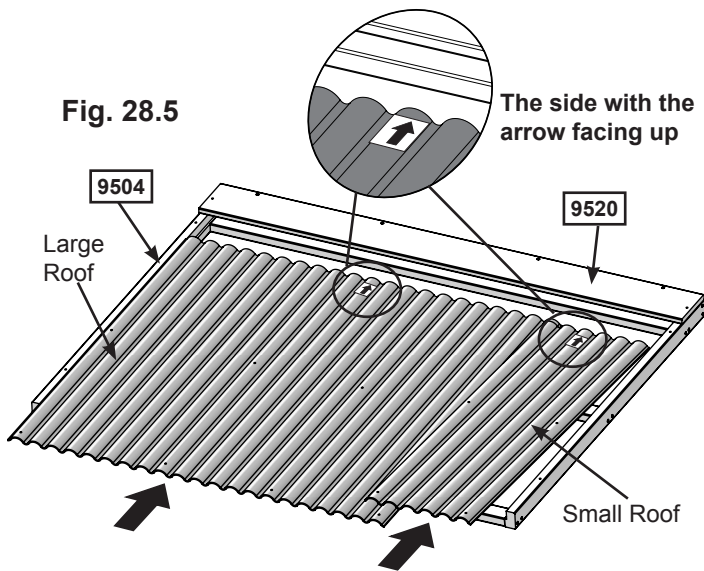

Fig. 28.6

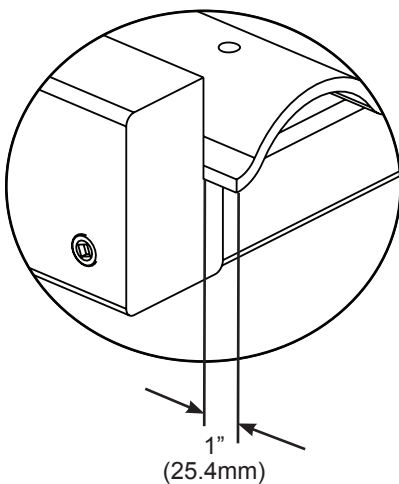

Fig. 28.7

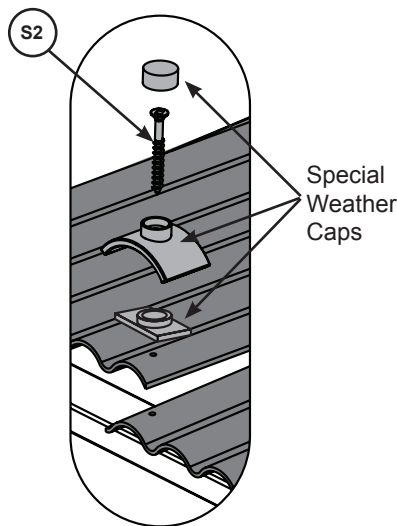
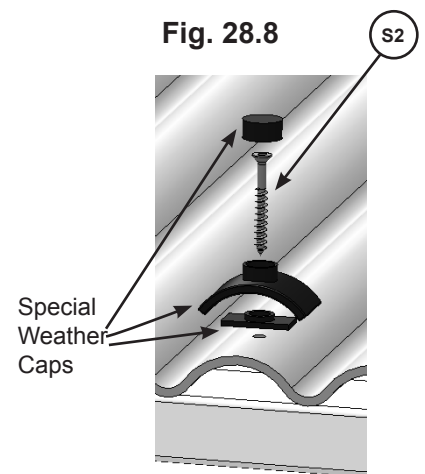

Fig. 28.8



Hardware

10 x #8 x 1-1/2" Wood Screw

Other Parts

1 x 1124 x 1067mm Roof Panel

1 x 370 x 1067mm Roof Panel

10 x Special Weather Caps

Step 29: Small Roof Panel Assembly Part 1

A: Lay flat 2 (9511) Roof Bottoms. Place 1 (9508) Roof Sleeper Short along the top of the Roof Bottoms taking note of the hole orientation. Attach (9508) Roof Sleeper Short to (9511) Roof Bottoms using 4 (S11) #8 x 2" Wood Screws. (fig . 29.1 & 29.2)

B: Place (9507) Roof Sleeper Short I along the bottom of (9511) Roof Bottoms taking note of the hole orientation. Attach using 4 (S11) #8 x 2" Wood Screws. (fig . 29.1 & 29.3)

C: Fit (9509) Roof Bottom B tight against (9511) Roof Bottom so that it lines up with the pre-drilled holes in the ends of (9508) Roof Sleeper Short and (9507) Roof Sleeper Short I. Attach using 2 (S11) #8 x 2" Wood Screws per end. (fig . 29.1 & 29.2 & 29.3)

D: Place (9512) Roof Cover over the top of (9509) Roof Bottom B, (9508) Roof Sleeper Short and (9507) Roof Sleeper Short I, making sure that it is flush with the edges. Attach using 6 (S20) #8 x 1-3/8" Wood Screws (fig. 29.4 & 29.5)

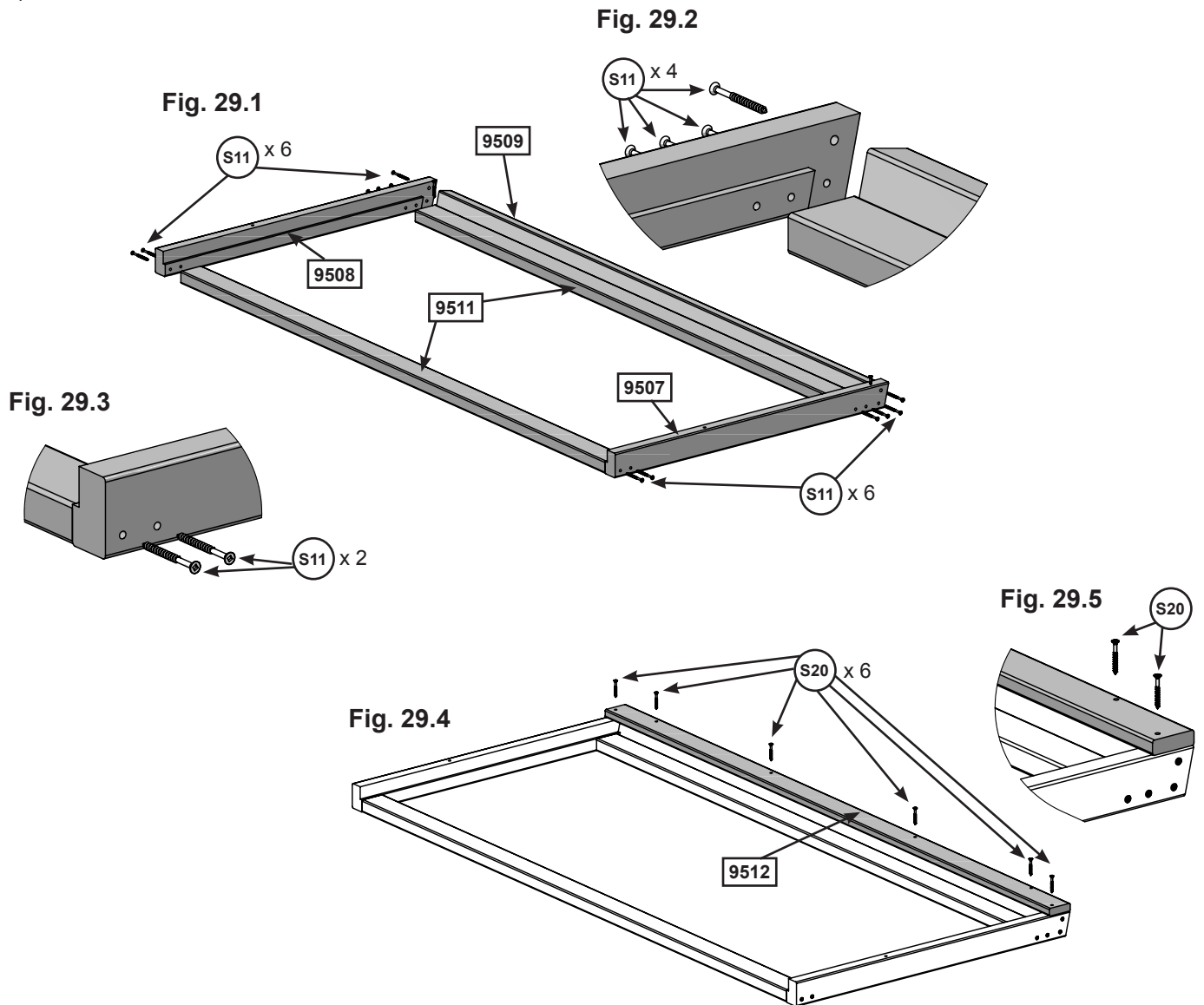

Wood Parts

1 x	9507	Roof Sleeper short I	1-1/4 x 2 x 26-25/64"
1 x	9508	Roof Sleeper short	1-1/4 x 2 x 26-25/64"
2 x	9511	Roof Bottom 1	1 x 2 x 53-5/8"
1 x	9509	Roof Bottom b	1-1/4 x 2 x 54-1/8"
1 x	9512	Roof Cover	5/8 x 2 x 56-1/8"

Hardware

12 x	(S11)	#8 x 2" Wood Screw
6 x	(S20)	#8 x 1-3/8" Wood Screw

Step 29: Small Roof Panel Assembly Part 2



Important: Do not over tighten hardware

E: Slide 1124 x 650mm Roof Panel under (9512) Roof Cover so that it's tight to (9508) Roof Sleeper. (fig.29.6 & 29.7 & 29.10)

F: Place 370 x 650mm Roof Panel in the remaining opening, under (9512) Roof Cover. The inside edge should overlap the Large Roof panel with the pre-drilled holes lining up. (fig. 29.6 & 29.7 & 29.10)

G: Pre-drill each hole using a 1/8" drill bit, place Special Weather Cap brackets over each hole in the Roof Panels then attach using 1 (S2) #8 x 1-1/2" Wood Screw per bracket. Press the Special Weather Cap over the top of each screw. (fig. 29.8 & 29.9 & 29.10)

Fig. 29.6

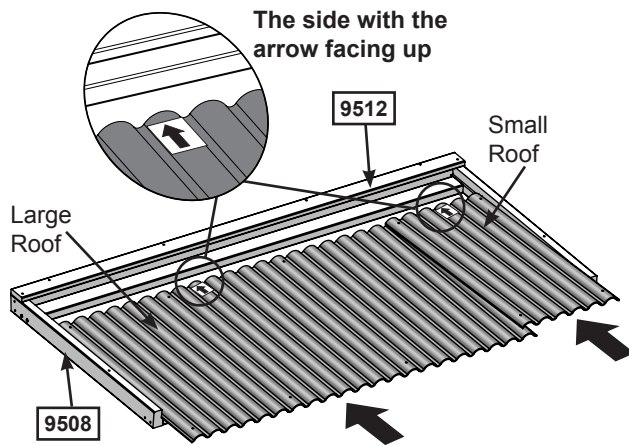

Fig. 29.10

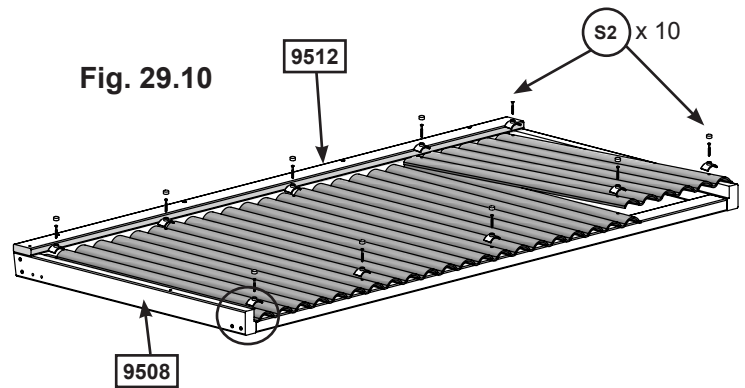

Fig. 29.7

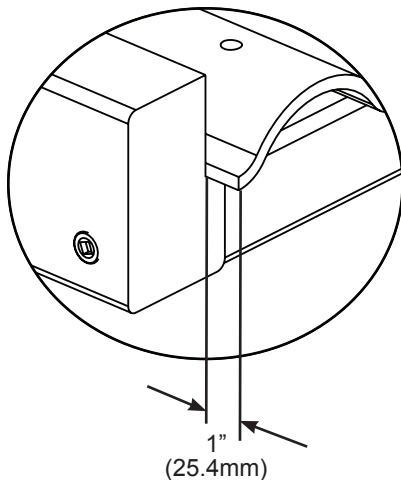

Fig. 29.8

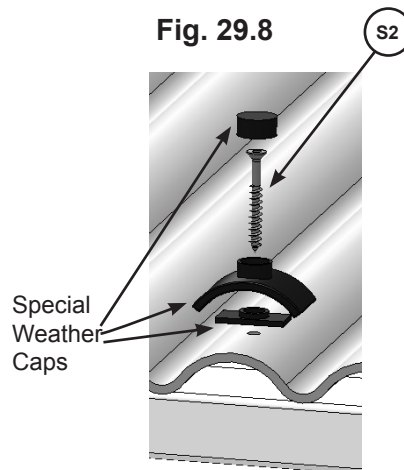
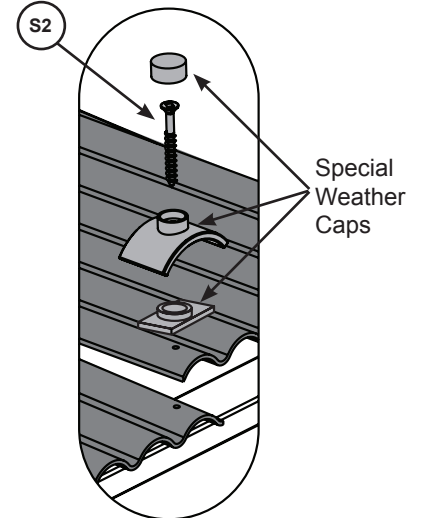

Fig. 29.9



Hardware

10 x (S2) #8 x 1-1/2" Wood Screw

Other Parts

1 x 1124 x 650mm Roof Panel

1 x 370 x 650 Roof Panel

10 x Special Weather Caps

Step 30: Attach Roof Panel Assemblies

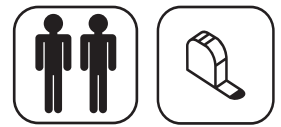

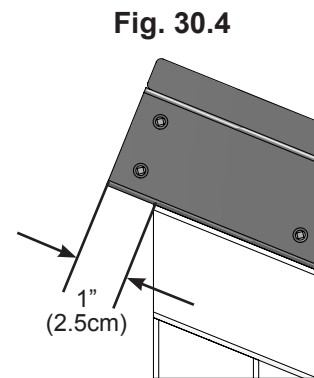
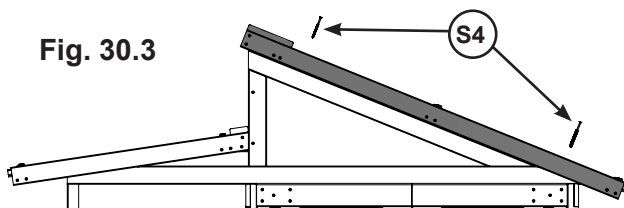
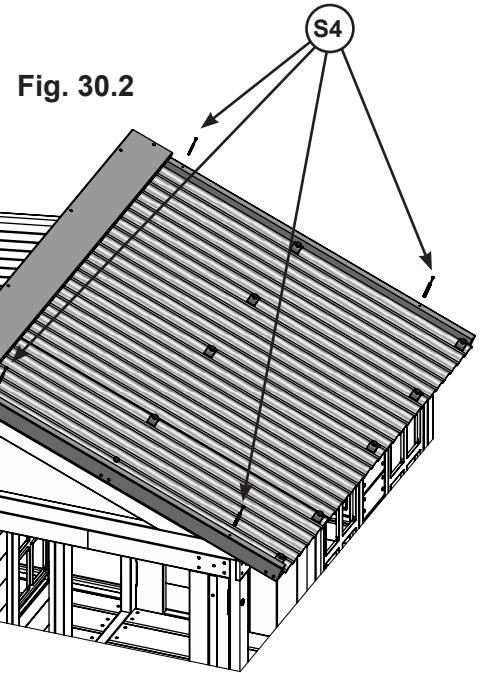
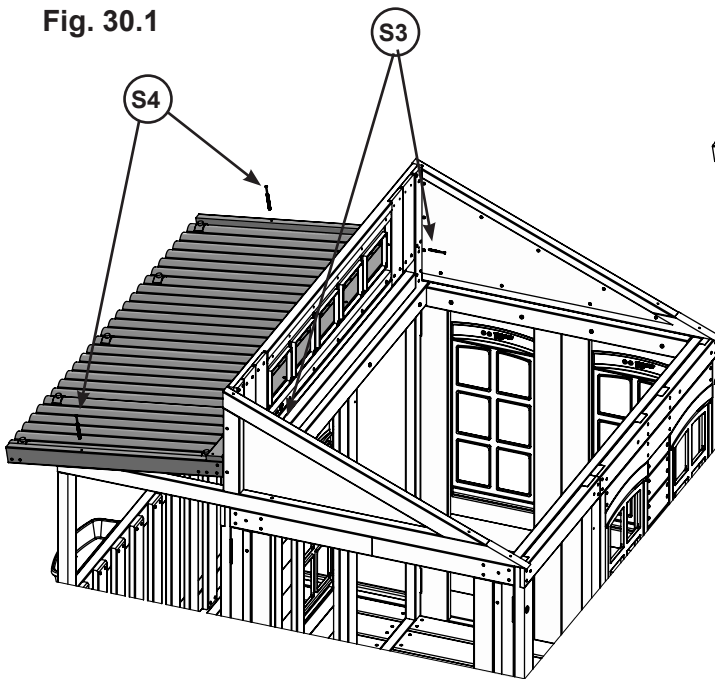

A: With a helper, lift the small roof panel assembly and place it over the deck, making sure that the top is tight to the window panel. Attach from the inside using 2 (S3) #8 x 2-1/2" Wood Screws and from the outside with 2 (S4) #8 x 3" Wood Screws.(Fig 30.1)

B: With at least 1 helper, lift the large roof panel assembly and place it over the fort, making sure that it is flush to the edges. There should be an overhang of approximately 1" at the roof peak (Fig. 30.3 & 30.4). Attach using 4 (S4) #8 x 3" Wood Screws.(Fig 30.2)



Hardware

- 6 x  #8 x 3" Wood Screw
- 2 x  #8 x 2-1/2" Wood Screw

Step 31: Install Mid Cross

A: Place (9514) Mid Cross at the top of the opening in the Slide End Panel making sure that it is flush to the inside wall. Place 1 flat bracket over each end of (9514) Mid Cross so that they are centered over the board and the panel. Attach using 4 (S0) #8 x 7/8" Truss Head Screws per bracket. (Fig. 31.1 & 31.2)

B: At the bottom of the opening, center 1 Flat Panel Bracket over the 2 panel sections and attach using 4 (S0) #8 x 7/8" Truss Head Screws. (Fig. 31.1 & 31.3)

Fig. 31.2

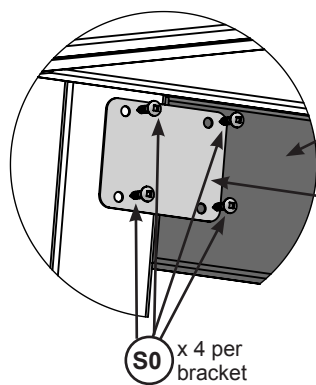

Fig. 31.1

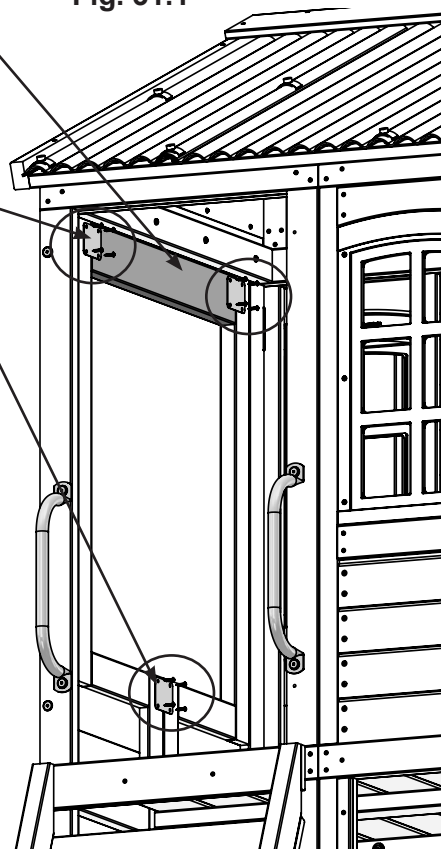
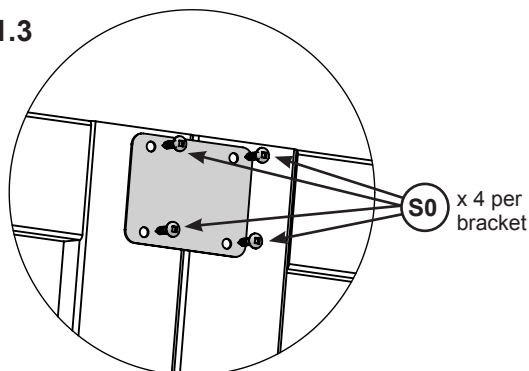

Fig. 31.3



Wood Parts

1 x **9514** Mid Cross 1-1/4 x 3-1/8 x 24-15/64"

Hardware

12 x **S0** # 8 x 7/8" Truss Head Screw

Other Parts

3 x Flat Panel Bracket

Step 32: Slide Section Assemblies Part 1



Note: When installing Pan Bolts make sure to look at holes so bolts go through the side with the round recess and the lock nuts go through the side with the hexagonal recess. (fig. 32.3)

A: Fit 2 TNR2 Slide Elbows together and attach with 8 (PB1) 1/4 x 3/4" Pan Bolts (with lock nut) as shown in fig. 32.1. It is very important to attach bolts as indicated.

B: Repeat Step A 3 more times to create 4 Elbow Sections in total.

C: Attach TNR3 Extended RT Flange and TNR3 Extended LT Flange together using 9 (PB1) 1/4 x 3/4" Pan Bolts (with lock nut) as shown in fig. 32.2. This creates the Flange Assembly.

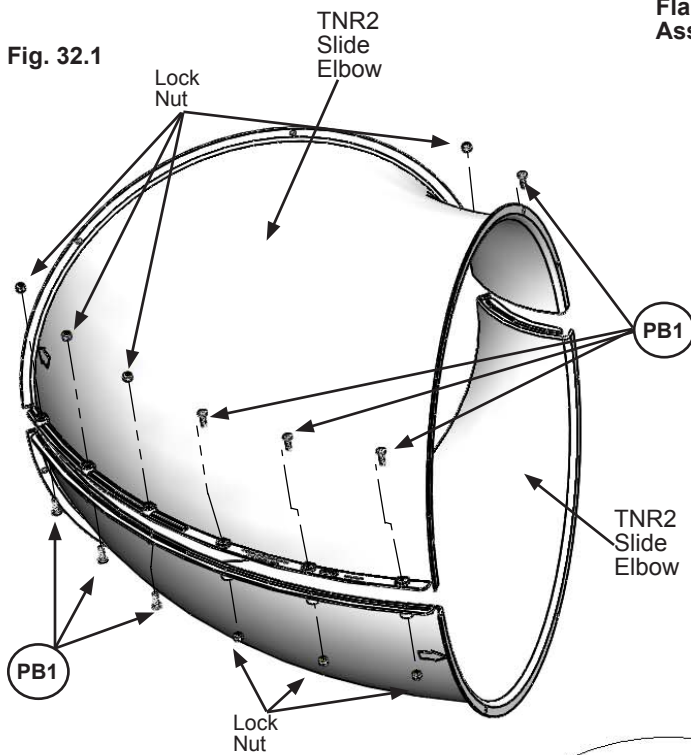

Fig. 32.2
Flange Assembly

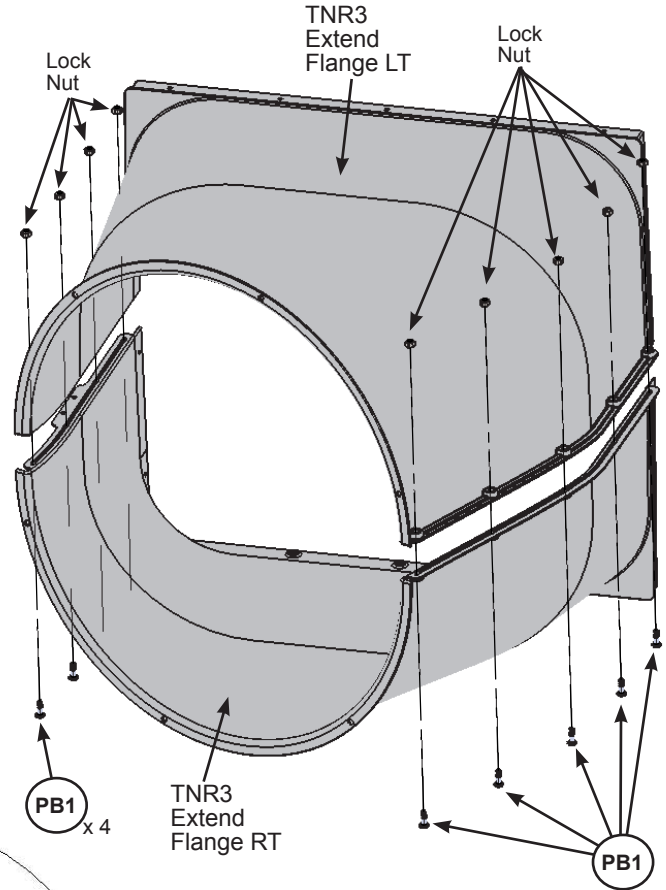
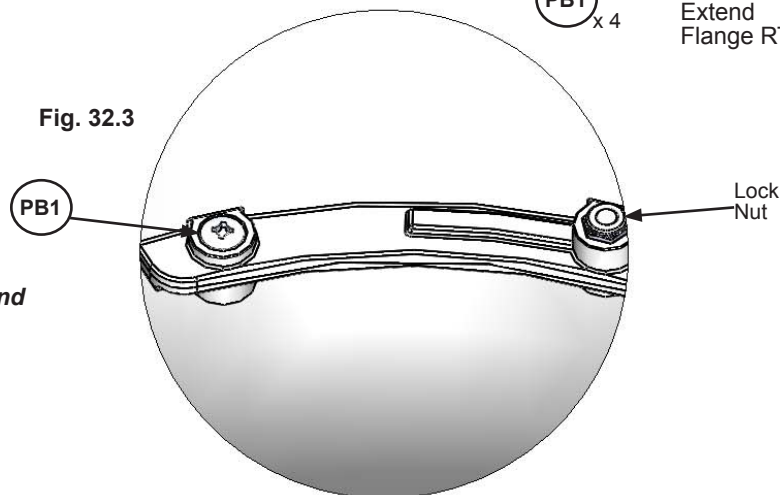

Fig. 32.3



Use a 7/16" open end wrench for nuts

Hardware

41 x (PB1) 1/4 x 3/4" Pan Bolt
(1/4" lock nut)

Other Parts

1 x TNR3 Extend Flange RT
1 x TNR3 Extend Flange LT
8 x TNR2 Slide Elbow

Step 32: Slide Section Assemblies Part 2

Note: When installing Pan Bolts make sure to look at holes so bolts go through the side with the round recess and the lock nuts go through the side with the hexagonal recess. (fig. 32.3)

D: Attach TNR2 Slide Exit Top and the remaining TNR2 Slide Elbow together using 8 (PB1) 1/4 x 3/4" Pan Bolts (with lock nut) as shown in fig. 32.4. It is very important to attach bolts as indicated. This creates the Exit Elbow Assembly.

Fig. 32.4

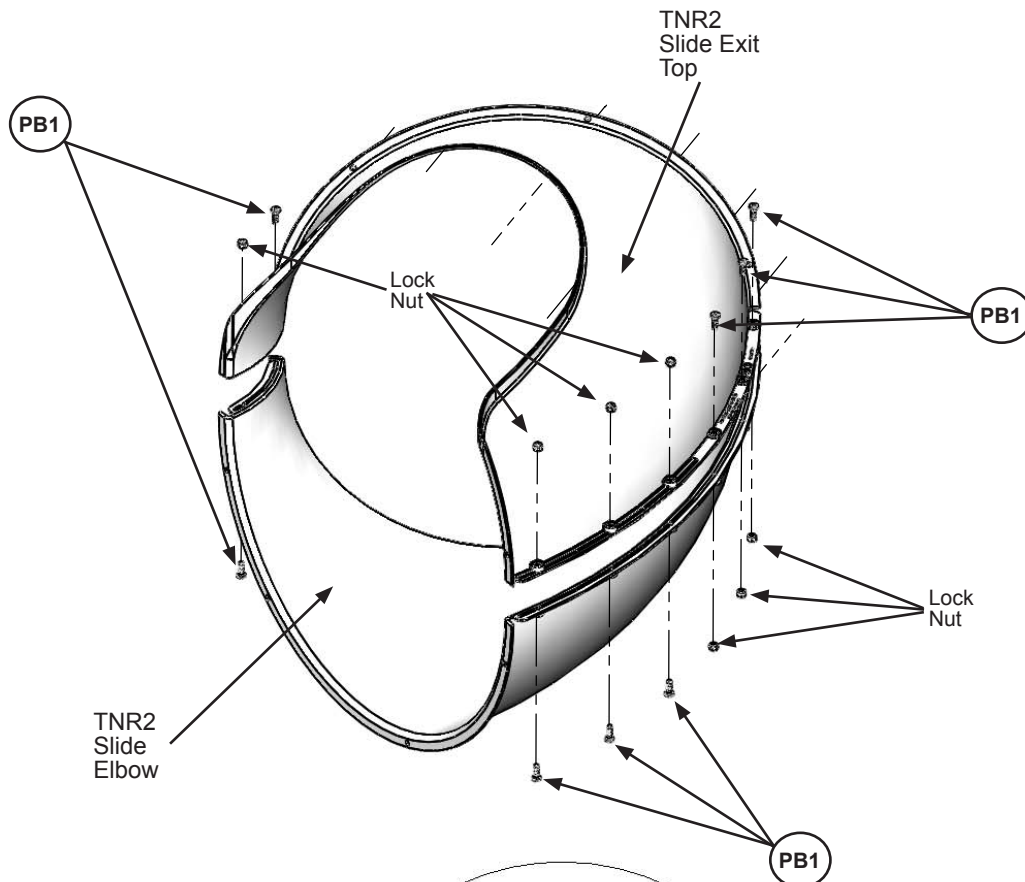
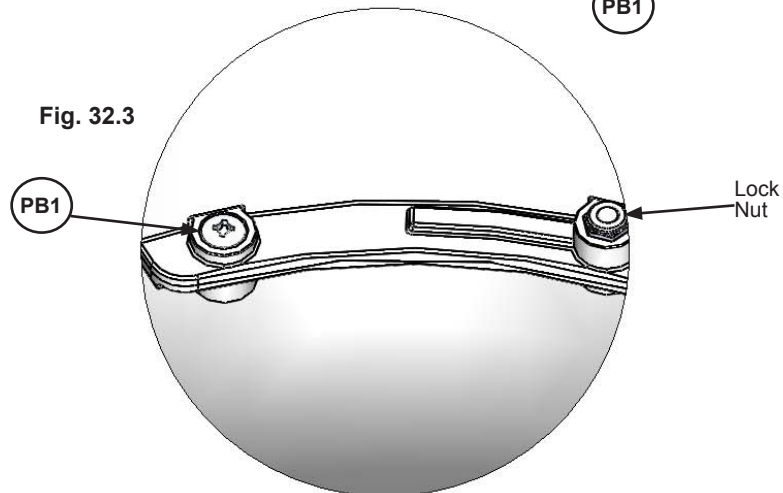



Fig. 32.3



Hardware

8 x  1/4 x 3/4" Pan Bolt
(1/4" lock nut)

Other Parts

1 x TNR2 Slide Exit Top
1 x TNR2 Slide Elbow

Step 33: Attach Flange Assembly to Fort

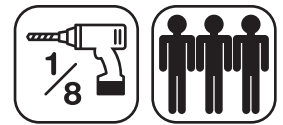

A: With a helper place the Flange Assembly in the opening so that it's flush to the (9514) Mid Cross as shown in fig. 33.1 & 33.2. Pre-drill 1/8" pilot holes in the bottom 4 mounting locations (approximate spots where circles are on figure), making sure the pre-drilled holes are a minimum of 2.5 cm (1") deep. (fig. 33.1)

B: Attach Flange Assembly to bottom of opening using 4 (S7) #12 x 2" Pan Screws (with #12 Screw Bezel) in the pre-drilled holes. (fig. 33.1) Make sure the flat surfaces of the Flange Assembly are flush to the (9514) Mid Cross as shown in fig. 33.3.

C: Attach the Flange Assembly flush to top of (9514) Mid Cross opening using 4 (S6) #12 x 1" Pan Screws (with #12 Screw Bezel) as shown in fig. 33.1 and to both sides using 5 (S6) #12 x 1" Pan Screws per side. (fig. 33.1)

Fig. 33.1
Inside View

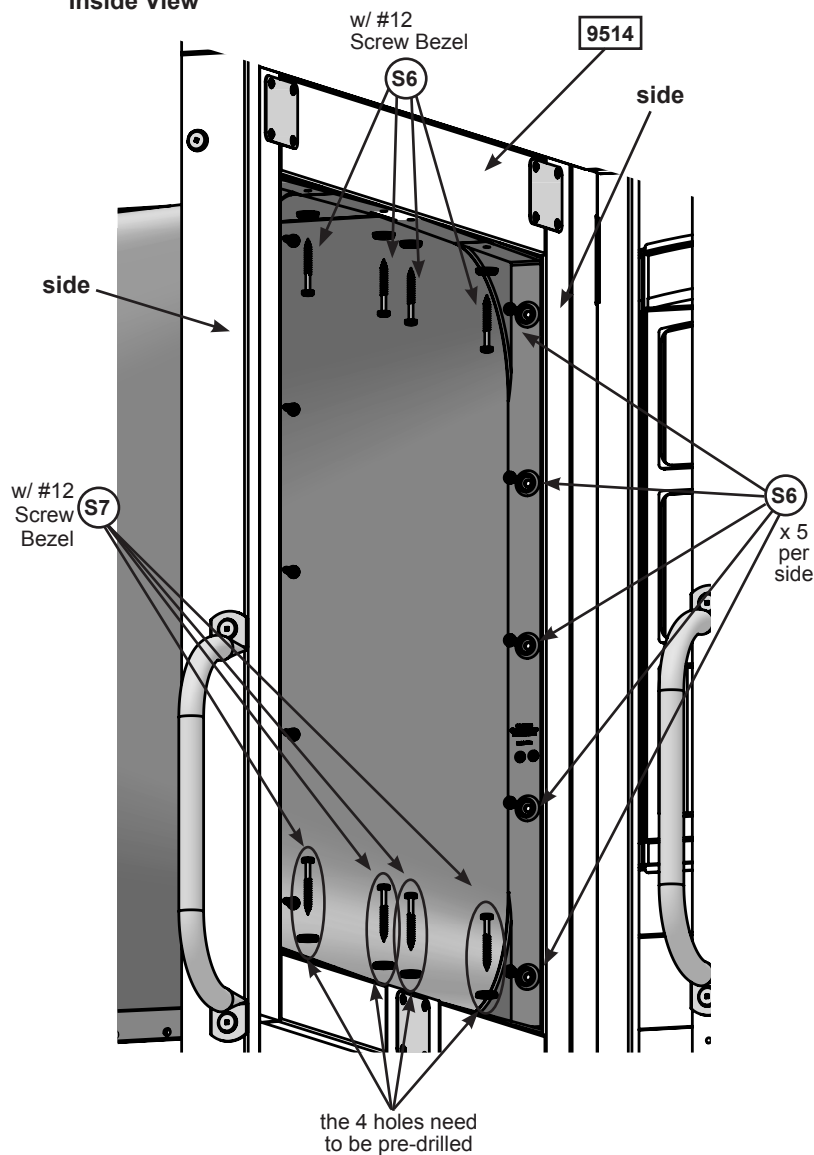
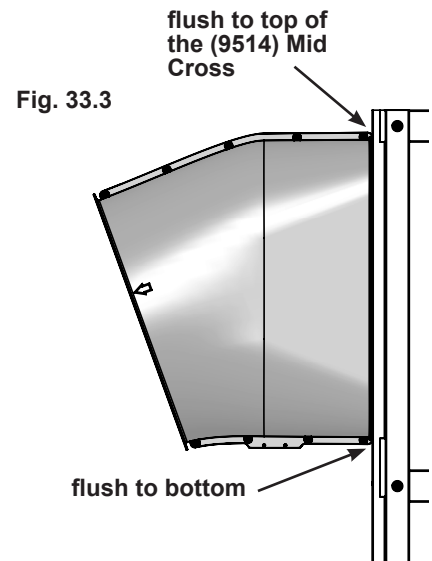
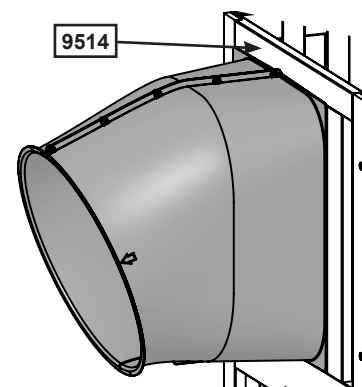

Fig. 33.2
Outside View



Hardware

- 14 x #12 x 1" Pan Screw
- 4 x #12 x 2" Pan Screw
- 8 x #12 Screw Bezel

Step 34: Attach SL Gusset



A: Place (9521) Gusset so that it's tight to (9264) Folding Panel Assembly Left A and attach to Flange Assembly with 2 (S6) #12 x 1" Pan Screws. (Fig. 34.1 & 34.2)

B: Pre-drill pilot hole with a 3/16" (4.8mm) drill bit then attach (9521) Gusset to (9264) Folding Panel Assembly Left A with 1 (WL5) 1/4 x 2-1/2" Wafer Lag (with flat washer). (Fig. 34.1 & 34.2)

Fig. 34.1

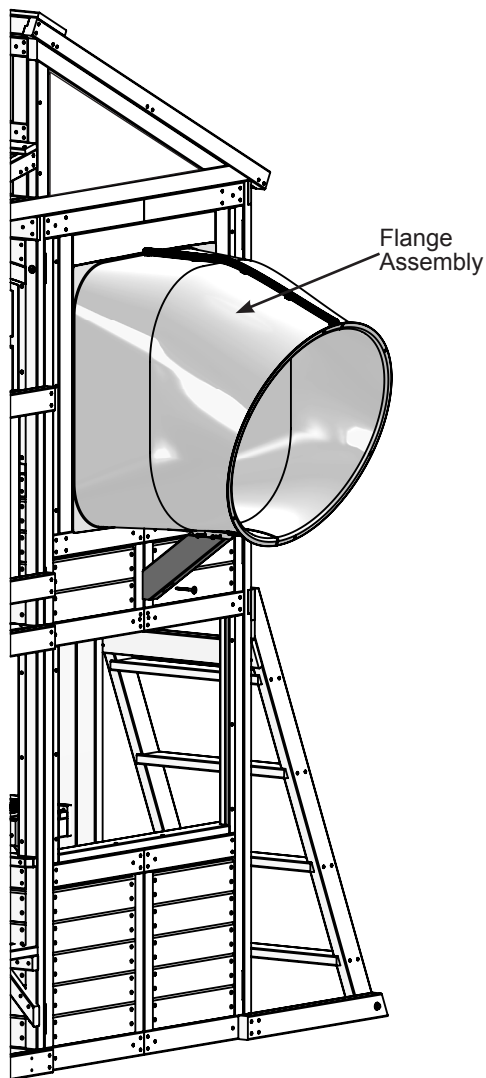
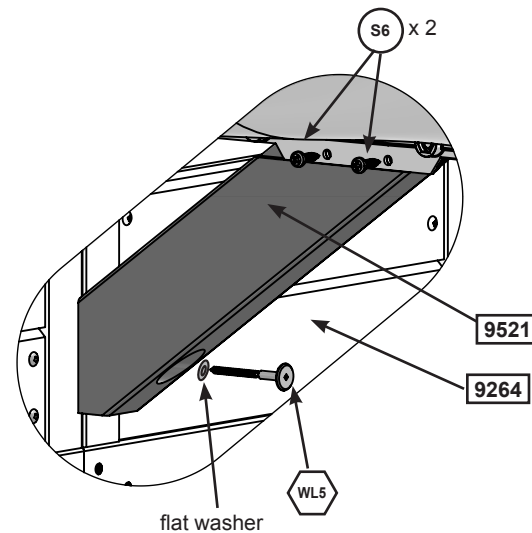

Fig. 34.2



Wood Parts

1 x 9521 Gusset 1-3/8 x 3 x 14-3/32"

Hardware

2 x S6 #12 x 1" Pan Screws

1 x WL5 1/4 x 2-1/2" Wafer Lag (with flat washer)

Step 35: Attach Elbow Assembly to Flange Assembly

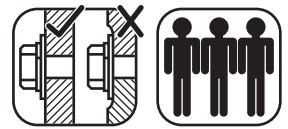

Note: Keep all bolts loose until further step.

A: Fit one of the Elbow Assemblies to the Flange Assembly by lining up the arrows on each assembly. Attach Elbow Assembly to Flange Assembly using 6 (PB1) 1/4 x 3/4" Pan Bolts and Square Lock Nut. (fig. 35.1, 35.2 and 35.3)

B: Attach one of the Elbow assemblies to another Elbow Assembly making sure to line up the arrows on each assembly. Attach 6 (1/4 x 12.7)mm Pan Bolt with Square Lock Nut. Repeat this instruction for 2 more. (fig. 35.2 and 35.3)

Use Quadrex Driver as a guide pin for each hole before inserting bolt.

Fig. 35.1

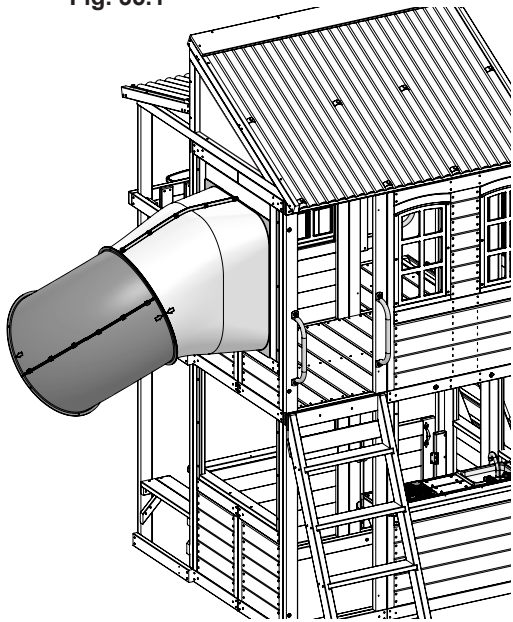
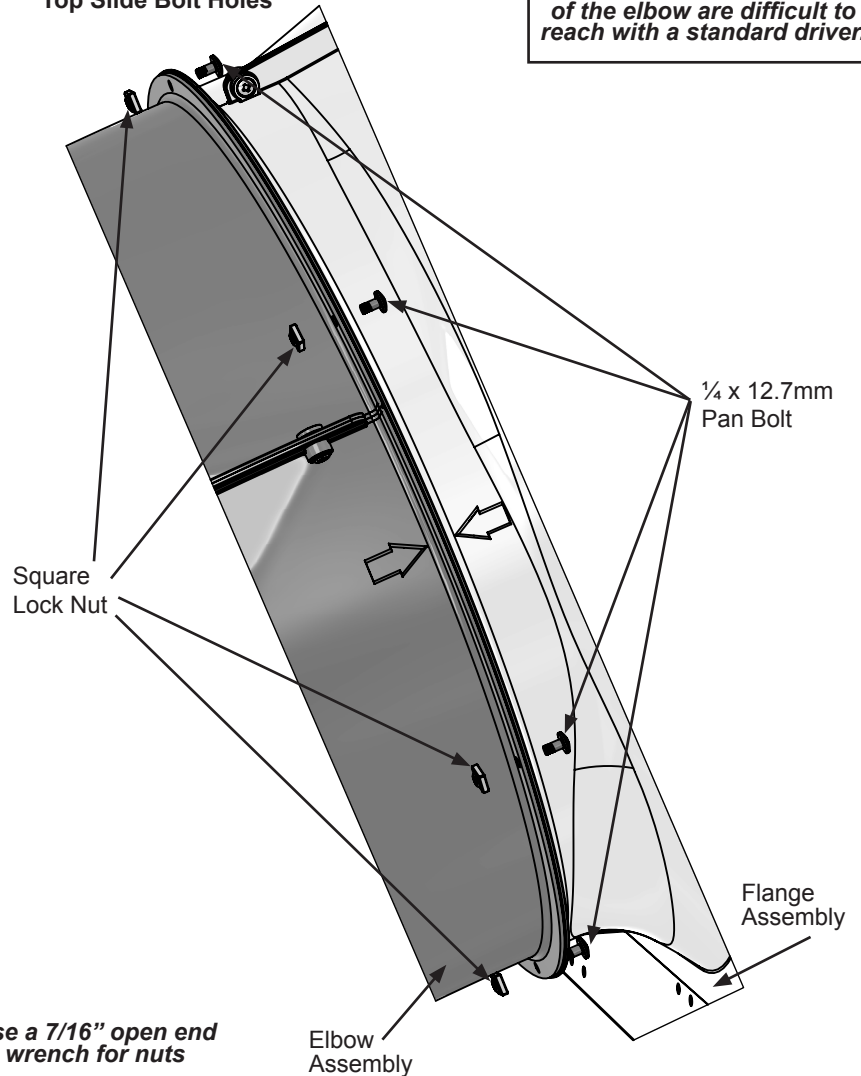

Fig. 35.2
Top Slide Bolt Holes



Quadrex Driver



Use special driver provided in locations where the curve of the elbow are difficult to reach with a standard driver.

Fig. 35.3

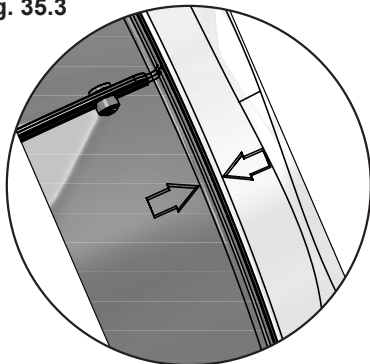

Align each elbow using the molded arrows.

Other Parts

1 x Quadrex Driver
24 x 1/4 x 12.7mm Pan Bolt
24 x 1/4" Square Lock Nut

Step 36: Attach TNR 3 Slide Exit to Elbow Assembly



A: Insert flange of Exit Elbow Assembly (slide elbow) into the slots on TNR3 Short Exit. (fig. 36.1)

B: Rotate Slide Exit and use Quadrex Driver as a guide pin so the holes are aligned and attach with 5 (PB1) 1/4 x 3/4" Pan Bolts (with lock nuts) starting with the bottom middle hole and working up each side. (fig. 36.2 and 36.3)

C: At this point make sure all the slide bolts are tight.

Use a 7/16" open end wrench to hold nut and then tighten bolt with Quadrex Driver.

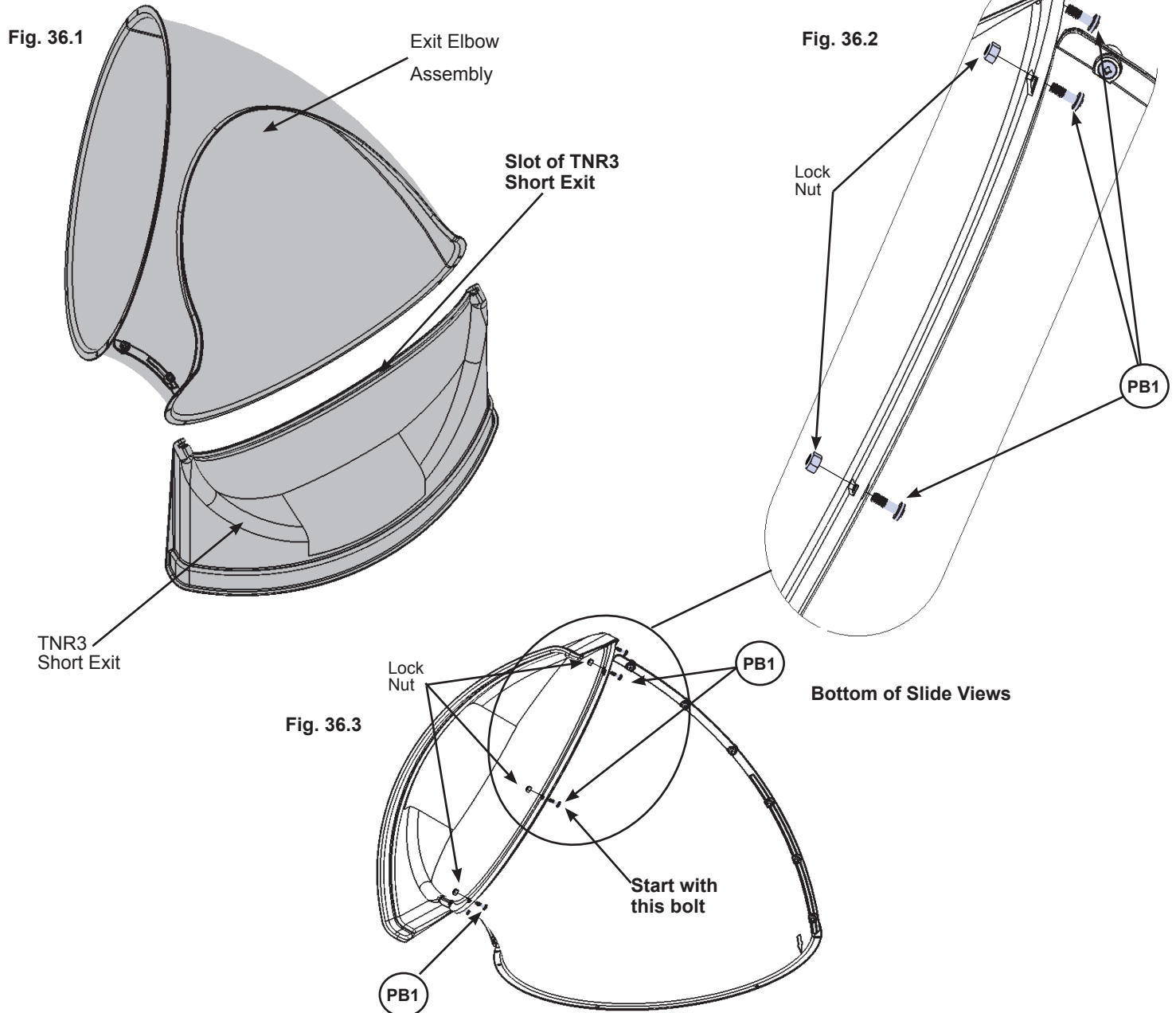

Hardware

5 x  1/4 x 3/4" Pan Bolt
(1/4" lock nut)

Other Parts

1 x TNR3 Short Exit

Step 37: Attach Exit End Assembly to Fort



A: Fit the Exit End Assembly to the last Elbow Assembly by lining up the arrows on each assembly. Notice the elbow orientation. (fig. 37.1). Attach with 6 (1/4" x 12.7mm) Pan Bolts and Square Lock Nuts. (fig. 37.2)

Fig. 37.1

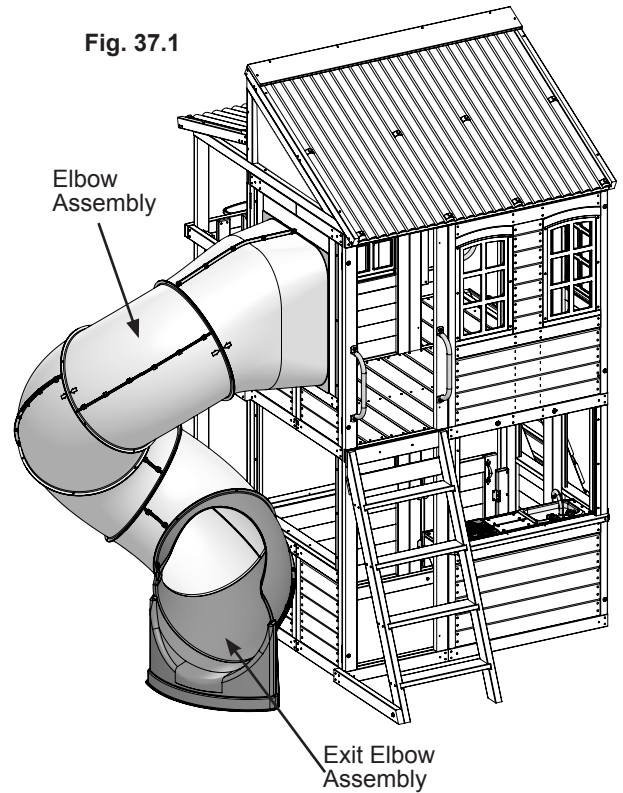
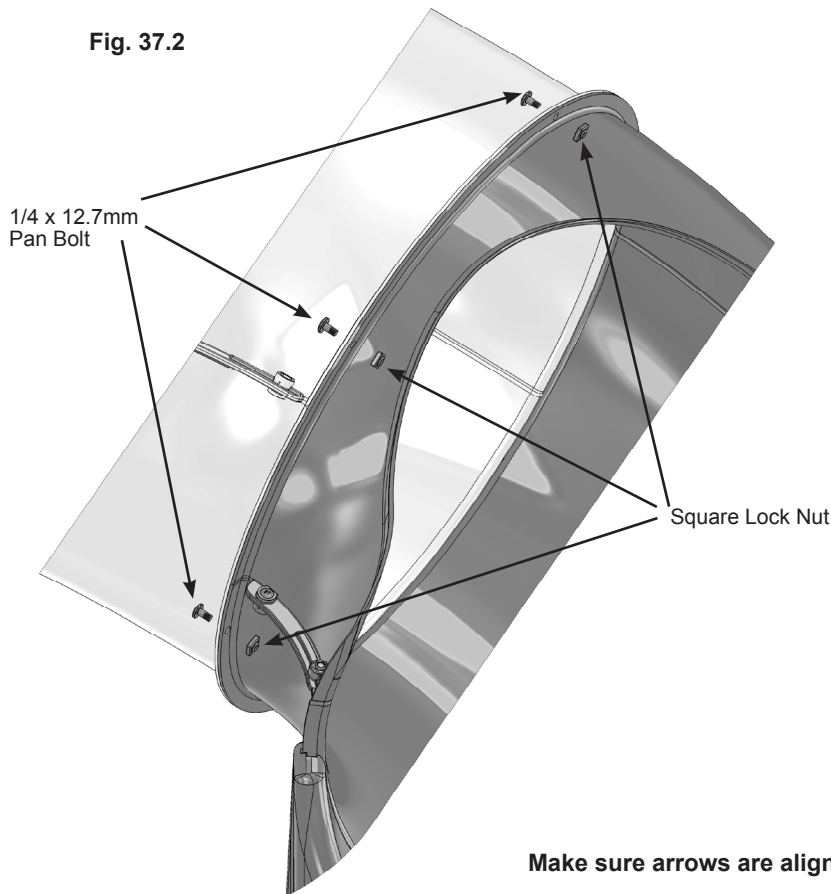

Fig. 37.2



Other Parts

6 x 1/4" x 12.7mm Pan Bolt
6 x 1/4" Square Lock Nut



Step 38: Attach TNR 4 Clamp Rings

A: Place 2 TNR4 Clamp Rings around each joint making sure to match the arrows with the end of the Clamp Ring as shown in (fig. 38.1 & 38.2).

B: Connect TNR4 Clamp Rings in 2 spots using 1 (PB6) 1/4 x 1" Pan Bolt (with lock nut) per side. (fig. 38.3)

Note: When installing Pan Bolts make sure to look at holes so bolts go through the side with the round recess and the lock nuts go through the side with the hexagonal recess.

Fig. 38.1

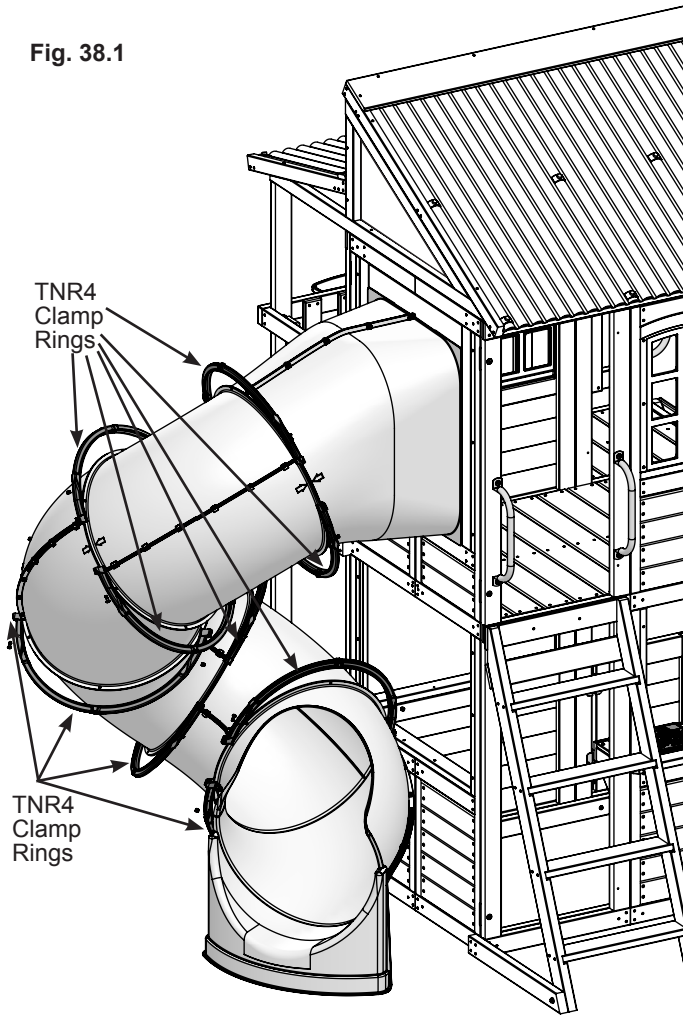

Note: For ease of assembly bottom set of clamp rings can be rotated 90 degrees to install bolts.

Fig. 38.2

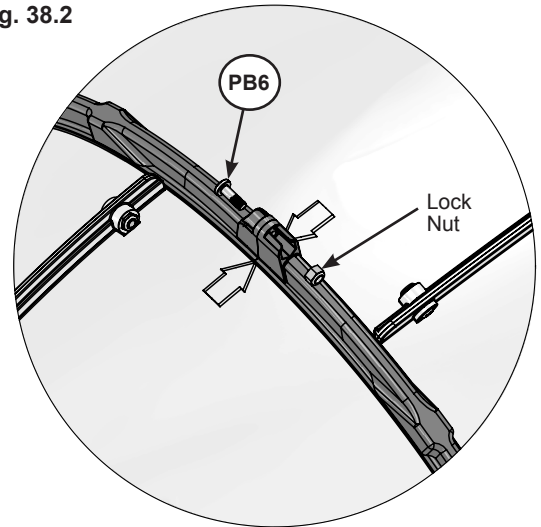

Make sure arrows are aligned

Fig. 38.3

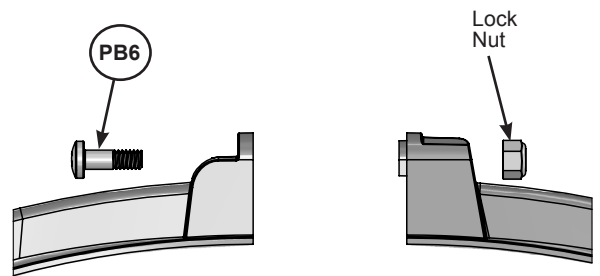

After the clamp rings are attached to the elbows, fasten them end to end with two pan bolts and lock nuts

Hardware

10 x  1/4 x 1" Pan Bolt
(1/4" lock nut)

Other Parts

10 x TNR4 Clamp Ring

Step 39: TNR Brace Assembly

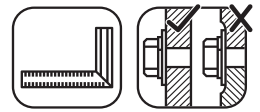

A: Attach (9493) Groud Brace C to (9492) Groud Brace B with 1 (H8) 1/4 x 4-1/4" Hex Bolt (with lock washer, flat washer and t-nut) in the top hole. Make sure both boards are square then attach with 1 (S11) #8 x 2" Wood Screw. (Fig. 39.1)

B: Place TNR Brace assembly centered over pilot holes of (9491) Groud Brace A. Attach with 2 (S4) #8 x 3" Wood Screw. (fig. 39.2 & 39.3)

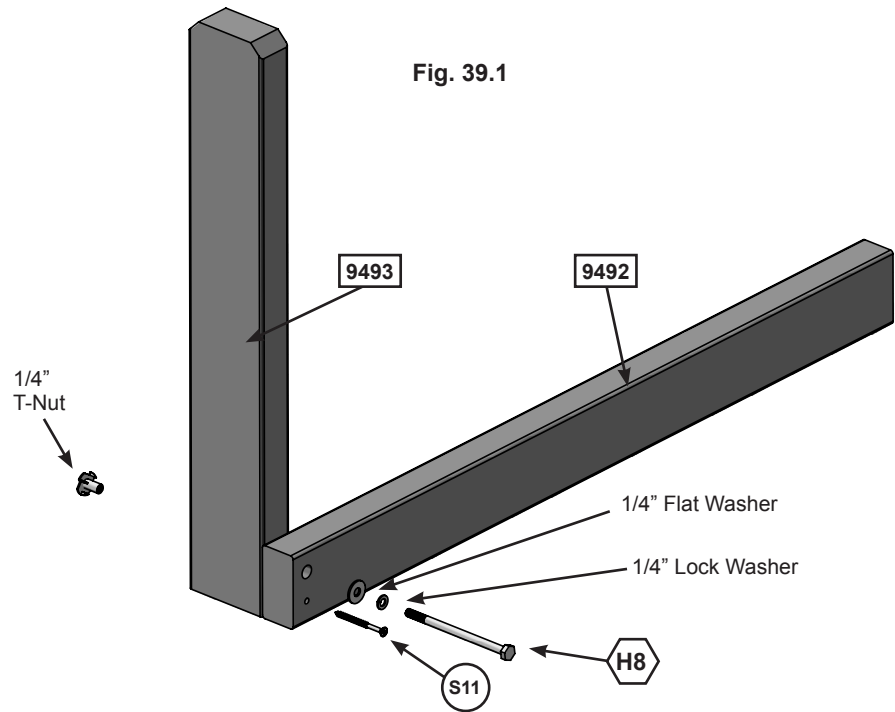

Fig. 39.1

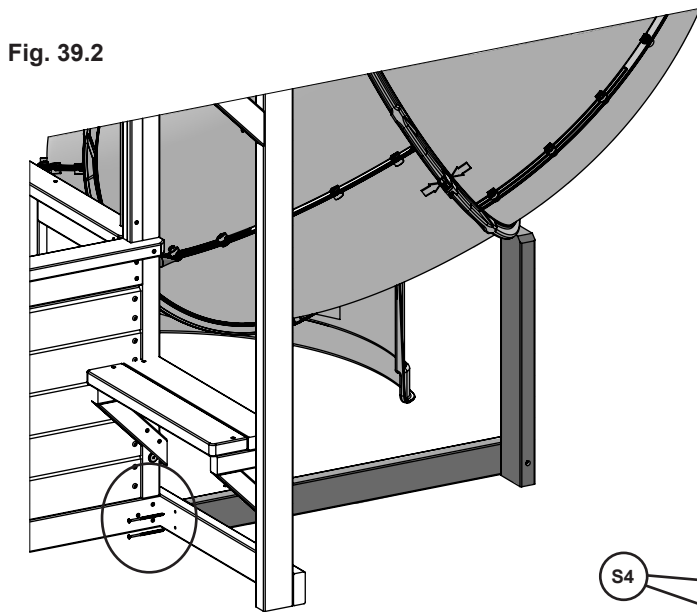

Fig. 39.2

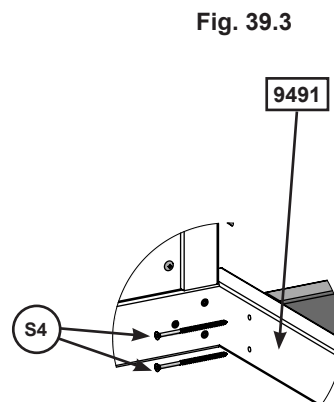

Fig. 39.3

Wood Parts

- 1 x 9493 Groud Brace C 1-1/4 x 3 x 19-1/2"
- 1 x 9492 Groud Brace B 1-1/4 x 2-3/4 x 27-1/2"

Hardware

- 1 x S11 #8 x 2" Wood Screw
- 1 x H8 1/4 x 4-1/4" Hex Bolt (1/4" lock washer, 1/4" flat washer, 1/4" t-nut)
- 2 x S4 #8 x 3" Wood Screw

Step 40: Attach Elbow Assemblies and TNR4 Slide

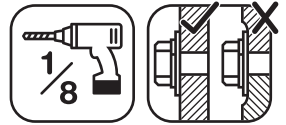

- A:** Place 1 TNR4 Post Mount Clamp on either side of the Clamp Ring so that the bent tops clip in behind the Clamp Ring. (fig. 40.1 & 40.2)
- B:** Insert the TNR4 Post Mount Base in between the 2 Post Mount Clamps and screw all pieces together using 1 1/4 x 14.5mm Pan Head Bolt and Square Nylock Nut. (fig. 40.2)
- C:** Attach TNR4 Post Mount Base to (9493) Groud Brace C, pre-drill with a 1/8" drill bit then attach with 2 (S6) #12 x 1" Pan Screws. (fig. 40.2)
- D:** Attach the Post Mount Clamp to the clamp ring using 1 (S37) #7 x 5/8" Pan Screw. (fig. 40.2)

Fig. 40.1

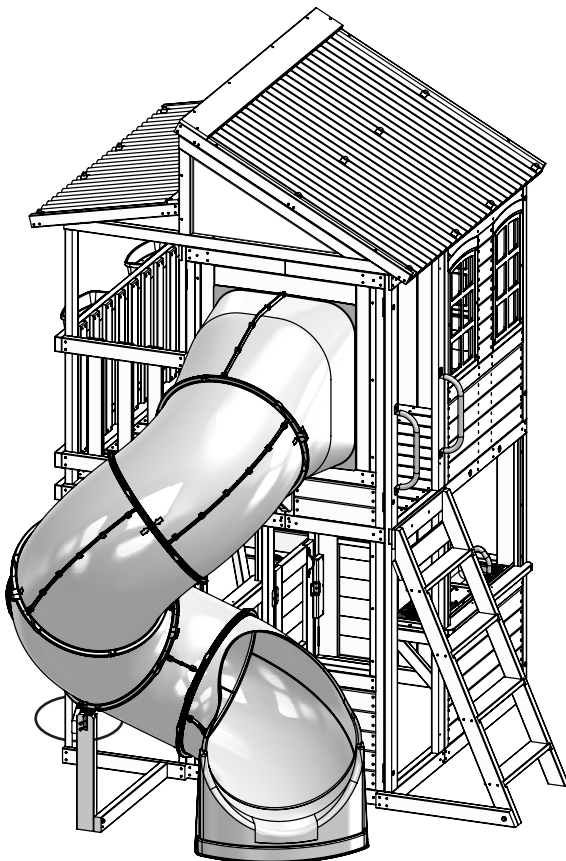
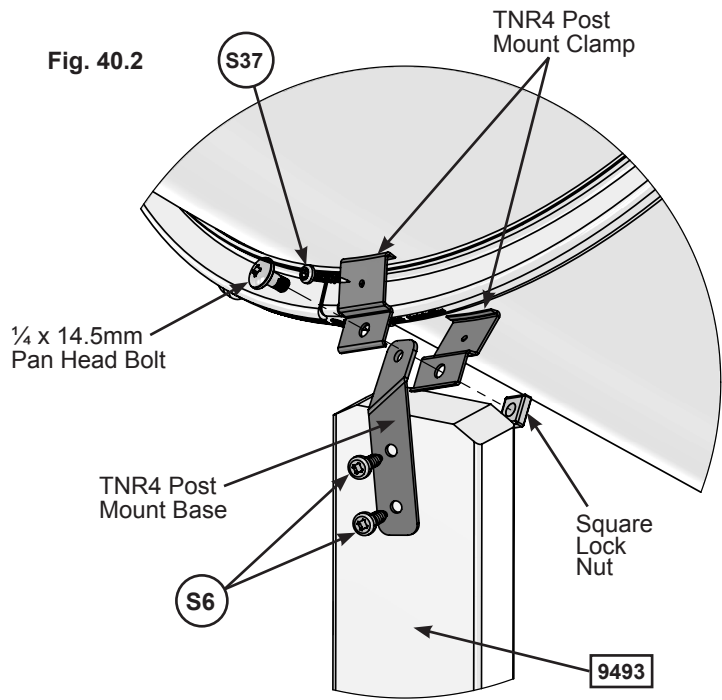

Fig. 40.2



Hardware

- 2 x (S6) #12 x 1" Pan Screw
- 1 x (S37) #7 x 5/8" Pan Screw

Other Parts

- 2 x TNR4 Post Mount Clamp
- 1 x TNR 4 Post Mount Base
- 1 x 1/4 x 14.5 mm Pan Head Bolt
- 1 x Square Lock Nut

Step 41: Attach TNR 3 Slide to Fort



A: On the fourth attached Elbow Assembly remove the pan bolt and nut which is facing the fort (installed in Step 32). (fig. 41.1) The bolt will no longer be needed, but keep the lock nut.

B: Loosely attach TNR3 Tube Support (at the slightly bent end) to the slide seam using 1 (PB6) 1/4 x 1" Pan Bolt (with flat washer and the previously removed lock nut). (fig. 41.2)

C: Rotate TNR3 Tube Support and attach to (9266) Folding Panel Assembly Right B using 1 (S6) #12 x 1" Pan Screw as shown in (fig. 41.2).

D: Fully tighten screw and bolt.

Fig. 41.1

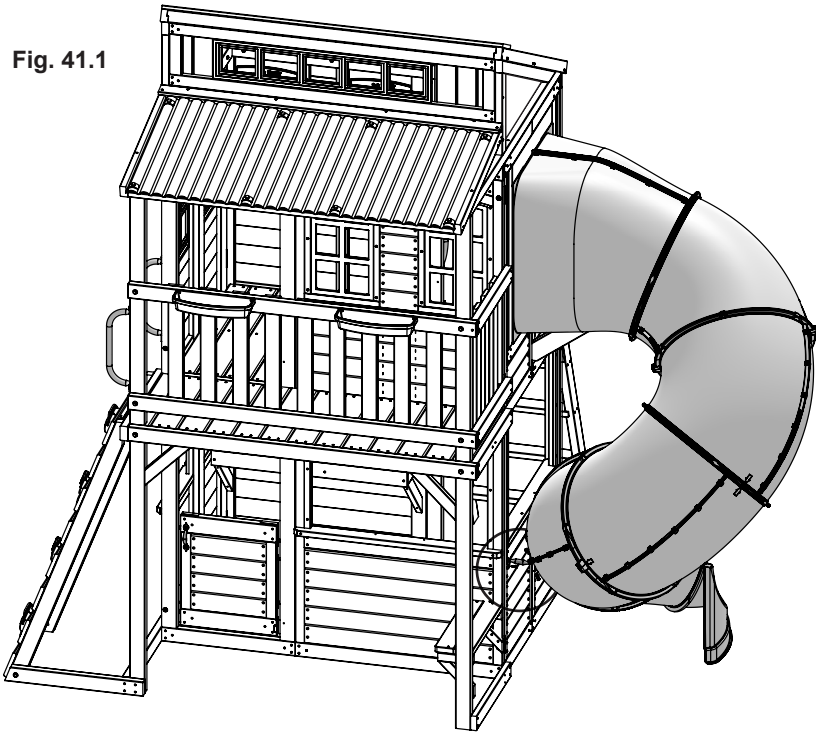
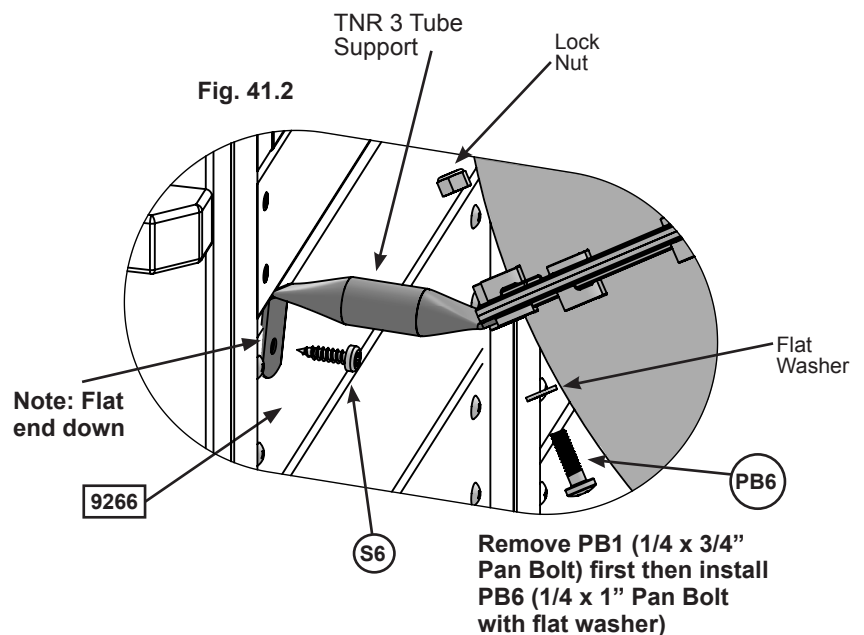

Fig. 41.2



Hardware

- 1 x (S6) #12 x 1" Pan Screw
- 1 x (PB6) 1/4 x 1" Pan Bolt
(1/4" flat washer & 1/4" lock nut - previously removed)

Other Parts

- 1 x TNR3 Tube Support

Step 42: Install Ground Stakes

MOVE FORT TO FINAL LOCATION PRIOR TO STAKING **FINAL LOCATION MUST BE LEVEL GROUND**

A: In the 6 places shown in fig. 41.1 drive the Rebar Ground Stakes 13" (33cm) into the ground against (9265) Folding Panel Assembly Left B, (9264) Folding Panel Assembly Left A, (9490) Groud Brace, (9491) Ground Brace A. Be careful not to hit the washer while hammering stakes into the ground as this could cause the washer to break off. (fig. 42.1 and 42.2)

B: Attach Ground Stakes using 1 (S7) #12 x 2" Pan Screw per ground stake as shown in fig. 42.3.

C: After driving stakes into the ground, check for sharp edges caused by the impact of the hammer. Smooth any sharp edges from impact area and touch up with outdoor paint.

⚠ Warning! To prevent tipping and avoid potential injury, stakes must be driven 13" (33cm) into ground. Digging or driving stakes can be dangerous if you do not check first for under-ground wiring, cables or gas lines.

Fig. 42.1

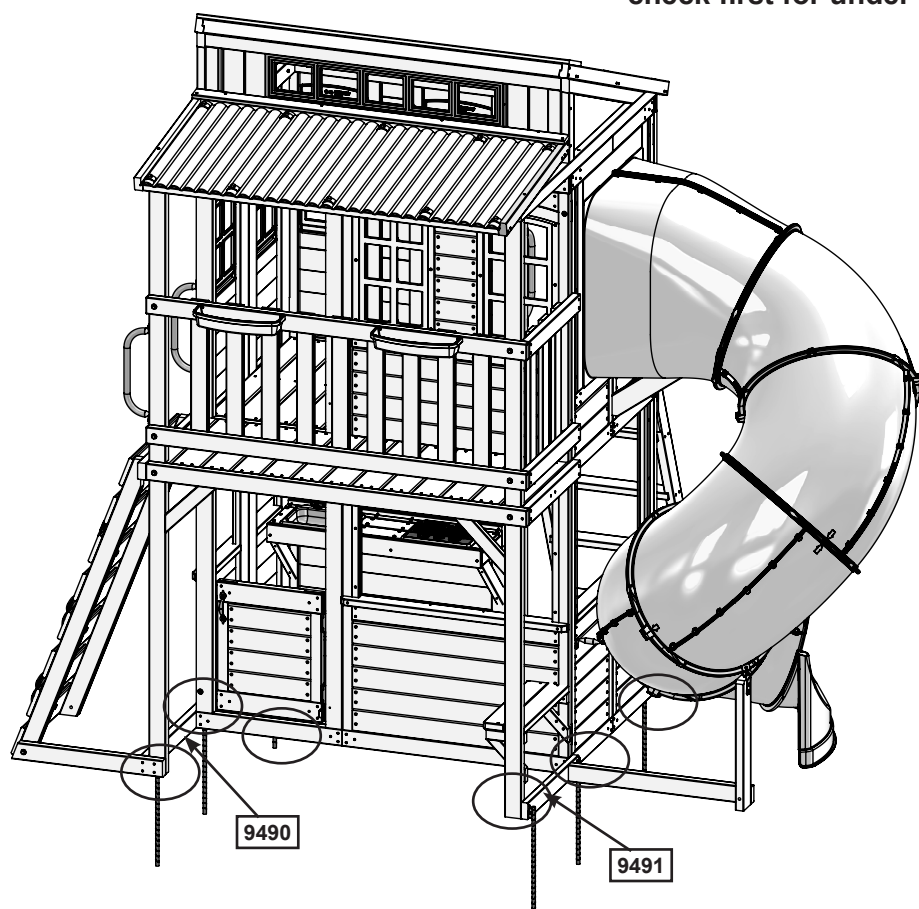

**SEE FRONT COVER
FOR SAFETY CLEARANCE**

Fig. 42.2

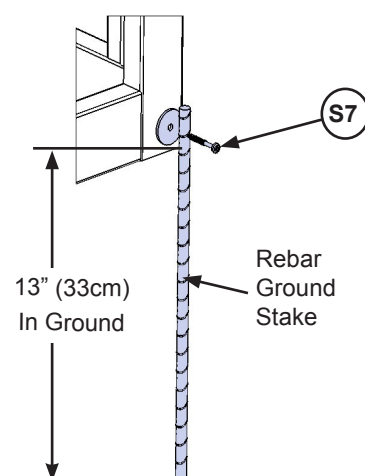

Hardware

6 x (S7) Pan Screw

Other Parts

6 x Rebar Ground Stake

Final Step: Attach I.D. Plaque

ATTACH THIS WARNING & I.D. PLAQUE TO THIS LOCATION ON YOUR PLAY EQUIPMENT!

This provides warnings concerning safety and important contact information. A Tracking Number is provided to allow you to get critical information or order replacement parts for this specific model.

WARNING
AVERTISSEMENT

CONTINUOUS ADULT SUPERVISION REQUIRED!

STRANGULATION HAZARDS

Never allow children to play with ropes, clotheslines, pet leashes, cables, chains or cord-like items when using this playset or to attach these items to play-set.

Never allow children to wear loose fitting clothing, ponchos, hoods, scarves, capes, necklaces, or items with draw-strings, cords or ties when using this play-set.

Never allow children to wear bike or sport helmets when using this play-set.

Failure to prohibit these items increases the risk of serious injury and death to children from entanglement and strangulation.

SERIOUS HEAD INJURY HAZARD

Maintain shock absorbing material under and around play-set as recommended in the Installation & Operating Instructions. Installation over concrete, asphalt, dirt, grass, carpet and other hard surfaces creates a risk of serious injury or death from falls to the ground.

SURVEILLANCE CONSTANTE D'ADULTES EST REQUIS!

Risques D'étranglement

Ne jamais laisser les enfants jouer avec des cordes, cordes à linge, laisses pour animaux, des câbles, des chaînes ou ces type articles pendant de l'utilisation de cet portique de jeu ou à l'attaché de ces éléments à la portique de jeu.

Ne jamais laissez les enfants de porter des vêtements amples, des ponchos, des hottes, des foulards, capes, des colliers ou des articles avec cordes attirant ou les cordons pendant l'utilisation de cet portique de jeu.

Ne jamais laissez les enfants porter un casque de vélo ou de sport quand ils utilisent ce portique de jeu.

Défaut d'interdire ces éléments augmente le risque de blessures graves et de décès des enfants de enchevêtrement et d'étranglement.

RISQUE DE BLESSURES GRAVES DU TÊTE

Maintenir le matériau absorbant les chocs sous et autour de la portique de jeu comme recommandé dans les instructions d'installation. Installation sur béton, de l'asphalte, sol, de l'herbe, tapis et autres surfaces dure crée un risque de blessure à la tête graves ou la mort causé par tomber à la sol.

THIS PRODUCT IS INTENDED FOR USE BY CHILDREN FROM AGES 3 TO 10; weight limit of 110 lbs. per child. Maximum number of users, Installation & Operating Instructions; other information is available at:

POUR LES ENFANTS DE 3 À 10 ANS D'ÂGE: limite de 110 Livres par enfant. Nombre maximum d'utilisateurs, installation et d'utilisation; d'autres informations sont disponibles sur:

www.KidKraft.com
 Contact us at: KidKraft
 Dallas, TX 75244 USA
 1-800-933-0771

Tracking Number:
Numéro de Suivi:

A: Attach KK Playset Plaque to a location on your set that is easily seen and read by a supervising adult using 4 (S37) #7 x 5/8" Pan Screws as shown below.

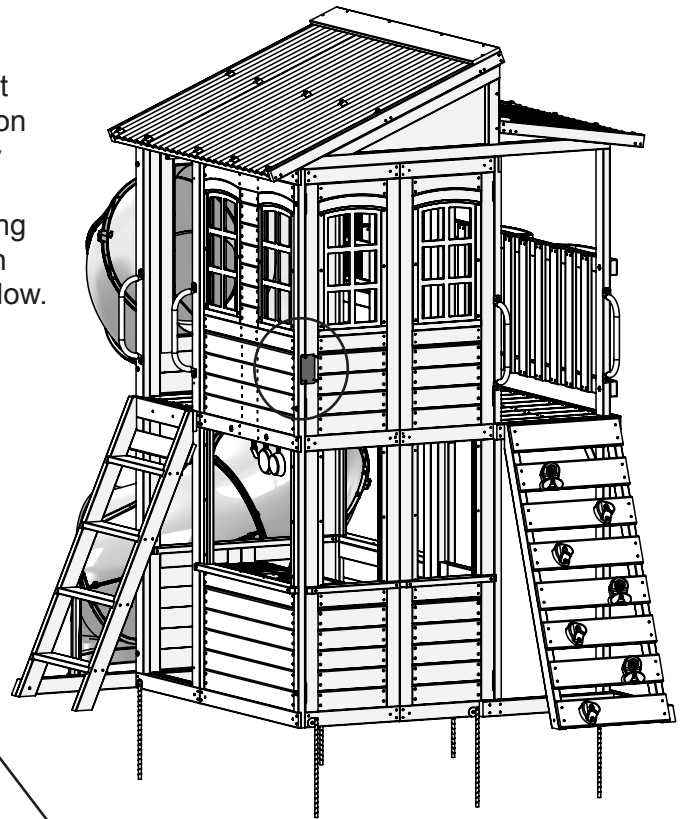

KK Playset Plaque

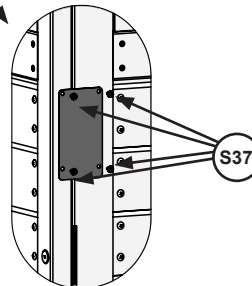

Hardware

4 x #7 x 5/8" Pan Screw

Other Parts

1 x KK Playset Plaque

