

Assembly Instructions























Instructions de montage

Caution : You must read this before you proceed

Note: Vous devez lire ceci avant de continuer

Care & Maintenance

Maintenance et entretien

-   ● Not for commercial use. For residential use only.
Pas pour un usage commercial. Usage résidentiel uniquement.
-   ● Furniture may scratch floors. We recommend using furniture pads to protect your floors.
Les meubles peuvent rayer le sol. Nous recommandons d'utiliser Les tapis de meubles protègent votre sol.
-   ● Do not put hot items directly on furniture surface.
Ne mettez pas quelque chose de chaud directement sur la surface du meuble.
-   ● Do not clean furniture with harsh cleansers or polish.
Ne nettoyez pas les meubles avec des détergents ou des vernis agressifs.
-   ● Do not place furniture under direct sunlight.
Ne laissez pas vos meubles à la lumière directe du soleil.
-   ● Do not place furniture near heating or cooling vents.
Ne placez pas les meubles près des événements de chauffage ou de refroidissement.
-   ● Do not write on furniture without a padded barrier to protect the surface.
N'écrivez pas sur des meubles qui n'ont pas de surface de protection rembourrée.
-   ● Do not place furniture outside . For indoor use only.
Ne laissez pas les meubles à l'extérieur. Pour usage intérieur uniquement.
-   ● Stains may be removed with mild soap solution and damp cloth.
Les taches peuvent être enlevées avec une solution savonneuse douce et un chiffon
-   ● Children should not climb or jump on the furniture.
Les enfants ne devraient pas grimper ou sauter sur les meubles.
-   ● Dust and pick-up spills using a clean, non-colored, lint-free cloth.
Utiliser un propre, non coloré et sans pelle pour déverser de poussière et de captage Tissu.

Please look into the Carton for hardware packs and legs.

Sets often ship in multiple boxes and may arrive a day or two apart.

S'il vous plaît vérifier s'il y a un emballage matériel et des jambes dans le carton.

Les costumes sont généralement livrés dans plusieurs boîtes et peuvent arriver séparés d'un jour ou deux.

Dining Chair/Chaise à manger

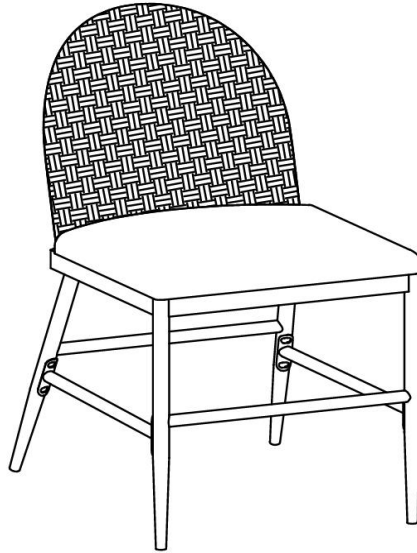

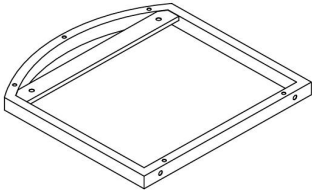
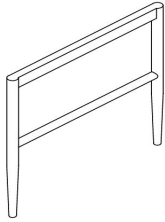
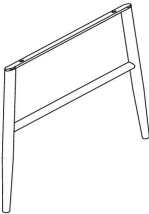
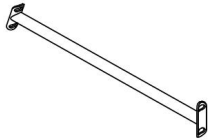
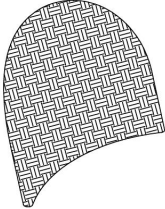

Parts List /Liste des pièces

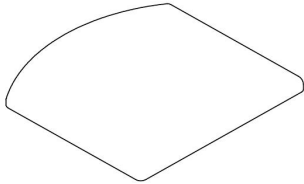
Label /Étiquettes	Picture/Photos	Description/Description	QTY/Quantité
A		Seat Panel Frame/Cadre de panneau de siège	1
B		Front Leg/Jambe avant	1
C		Hind Leg/Jambe arrière	1
D		Legs Connection Pole/Poteau de connexion de jambes	2
E		Backrest/Le dossier	1

F		Seat Panel/Panneau de siège	1
---	--	-----------------------------	---

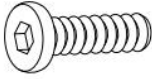
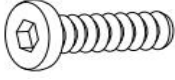
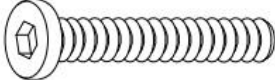
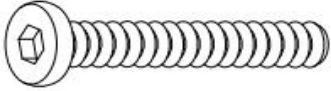
Hardware/Hardware

Label /Étiquettes	Picture/Photos	Description/ Description	QTY/ Quantité
①		Allen Wrench /Clé hexagonale intérieure	1
②		Bolt/Le loquet (M6*16MM)	10+1
③		Bolt/Le loquet (M6*20MM)	2+1
④		Bolt /Le loquet (M6*35MM)	2+1
⑤		Bolt/Le loquet (M6*50MM)	5+1
⑥		Washer/Rondelles	17+1

Assembly Preparation/Préparation de l'assemblage

Before Beginning Assembly: Avant de commencer l'assemblage:

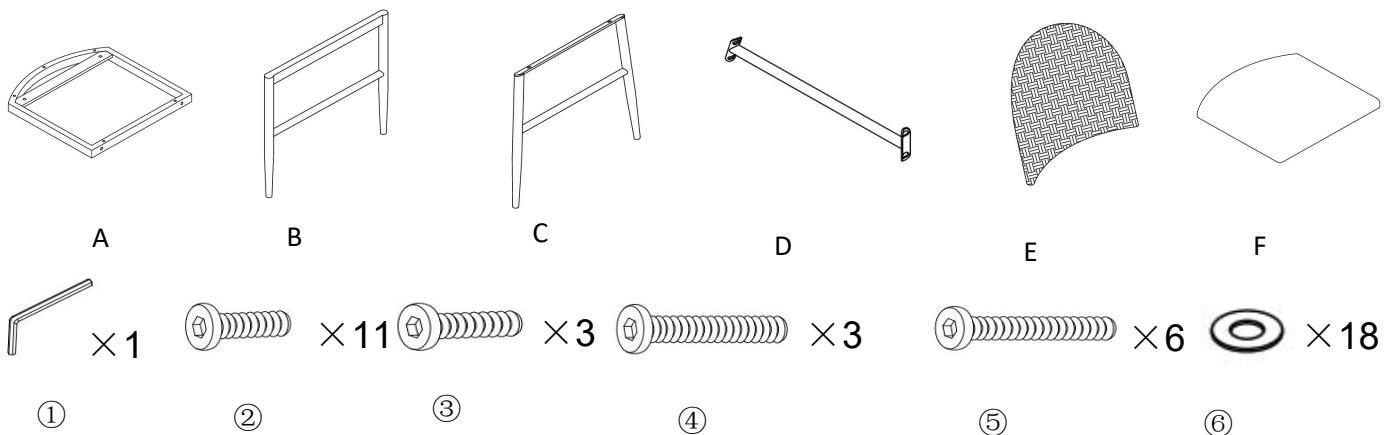

• Read instructions, cover to cover-



• Have 2 adults on hand for assembly-



• Do not assemble on flooring or carpet-



• Assemble on a clean non-marring surface (packing foam)-



• Save all packaging until finished-



- Lisez attentivement les instructions.



- 2 adultes étaient présents pour le montage.



- Ne pas assembler sur le sol ou la moquette.



- Assemblage sur une surface propre et non endommagée (mousse de remplissage).



- Conservez tous les emballages jusqu'à ce qu'ils soient finis.

Assembly Steps/Étapes d'assemblage

Overview/Aperçu

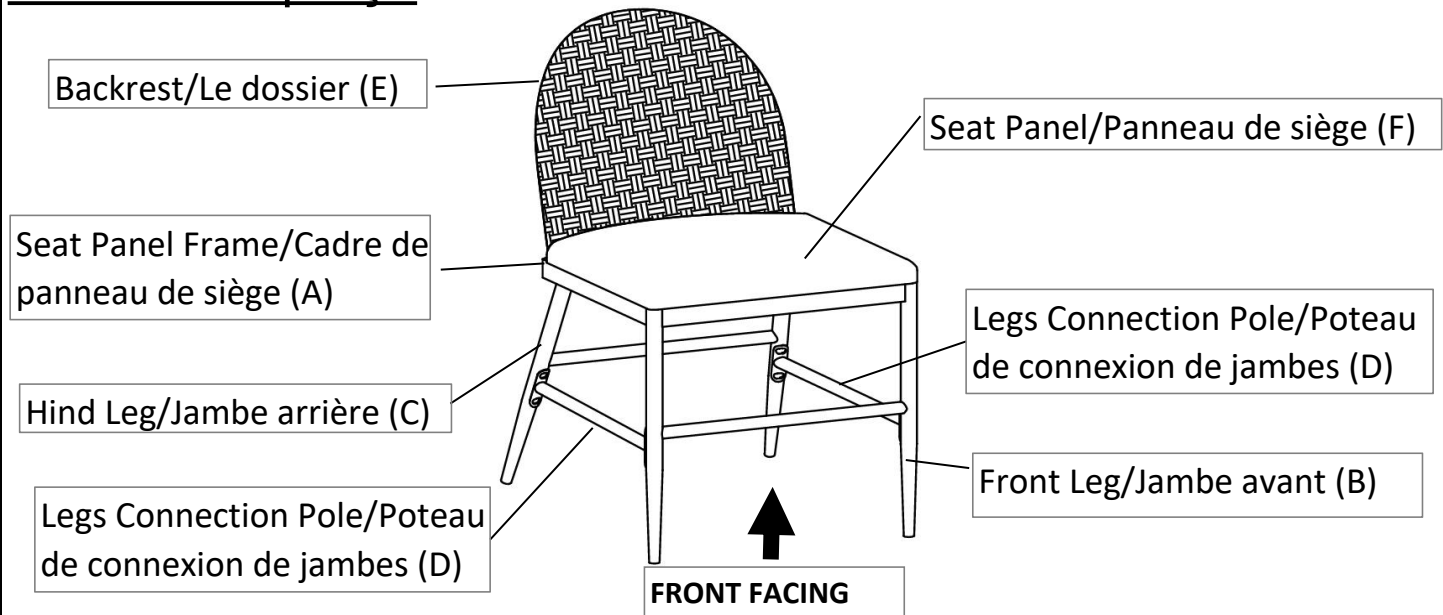

This Dining Chair has multiple parts and may require up to 30 minutes to assemble.

To give you an overview of the Dining Chair parts, the above picture is to help you put the various parts into perspective. Please read through the instructions herebelow to familiarise yourself with the parts and steps before assembly.

Ce Chaise à manger a plusieurs pièces et peut prendre jusqu'à 30 minutes pour assembler.

Pour vous donner un aperçu des pièces de barstool, les images ci - dessus sont là pour vous aider à mettre les pièces en perspective. Veuillez lire attentivement les instructions ci - dessous pour vous familiariser avec les pièces et les étapes avant de les assembler.

Step 1

Étape 1

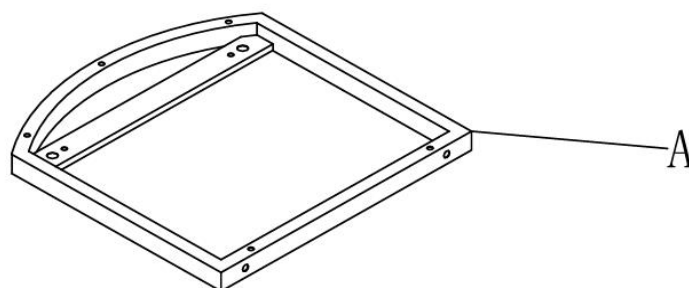

Open the carton and place all the parts onto a clean, non-marring surface.

Place Backrest(A) on the ground, as shown in picture above.

Ouvrez le carton et placez toutes les pièces sur une surface propre et sans marbrure.

Placez Cadre de panneau de -sp (A) au sol, comme le montre l'image ci-dessus.

Step 2 Étape 2

③ × 2

⑤ × 2

⑥ × 2

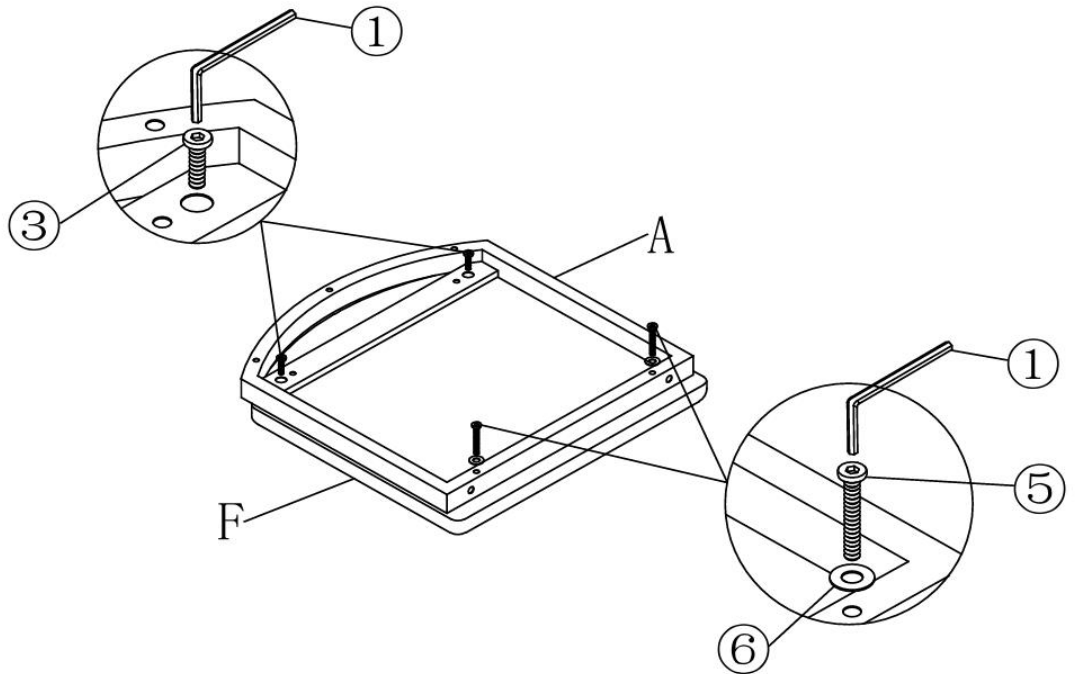

Attach Seat Panel Frame (A) to the Seat Panel (F) using Bolts (③), Bolt (⑤) and Washer (⑥) with Allen Wrench(①).

TIGHTEN ALL THE BOLTS.

Utilisez la clef à allen (①) pour fixer le cadre du panneau de siège (A) au panneau de siège (F) à l'aide des boulons (③), du boulon (⑤) et de la rondelle (⑥).

SERREZ TOUS LES BOULONS.

Step 3 Étape 3

② × 2

⑥ × 2

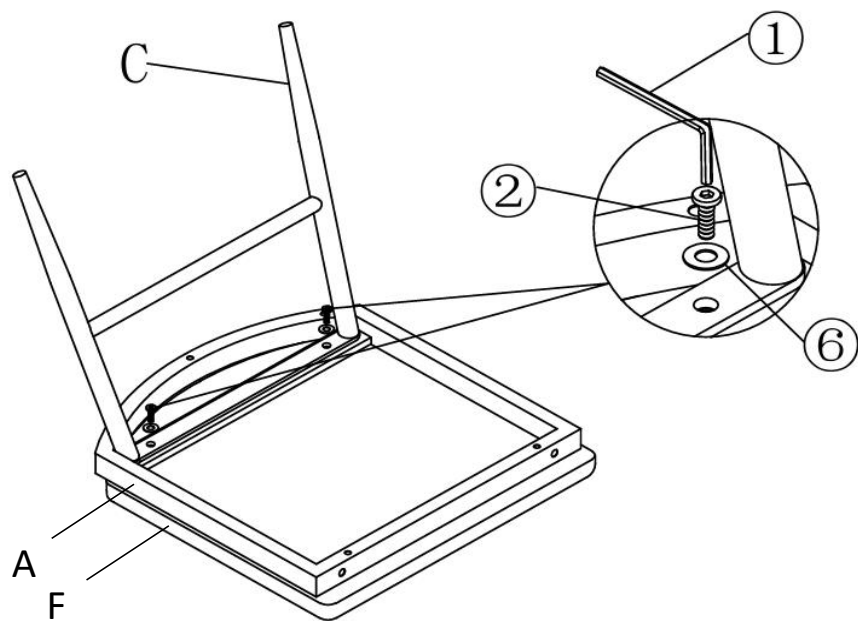

Attach the Hind Leg (C) to the Partially assembled Seat Panel (F) and Seat Panel Frame (A) using Bolts (②) and Washer (⑥) with Allen Wrench(①).

DO NOT FULLY TIGHTEN THE BOLTS.

Fixer la jambe arrière (C) au panneau de siège partiellement assemblé (F) et au cadre du panneau de siège (A) à l'aide de boulons (②) et d'une rondelle (⑥) avec une clé Allen (①).

Ne pas serrer complètement les boulons.

Step 4 Étape 4

④ × 2

⑥ × 2

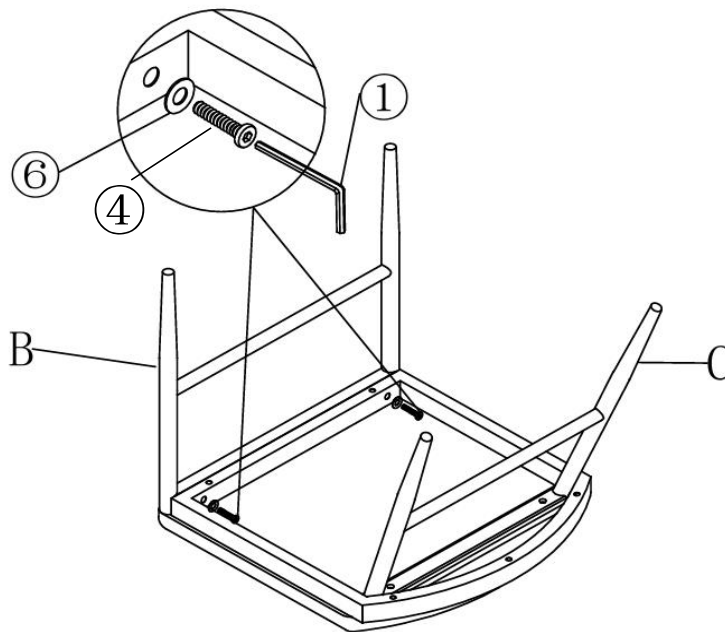

Using Bolts(④) and Washer (⑥) with Allen Wrench(①) to connect the Front Leg (B) to Seat Panel Frame (A) as shown above.

DO NOT FULLY TIGHTEN THE BOLTS.

Utiliser des boulons (④) et une rondelle (⑥) avec une clé Allen (①) pour connecter la jambe avant (B) au cadre du panneau de siège (A) comme indiqué ci-dessus.

Ne pas serrer complètement les boulons.

Step 5 Étape 5

② × 8

⑥ × 8

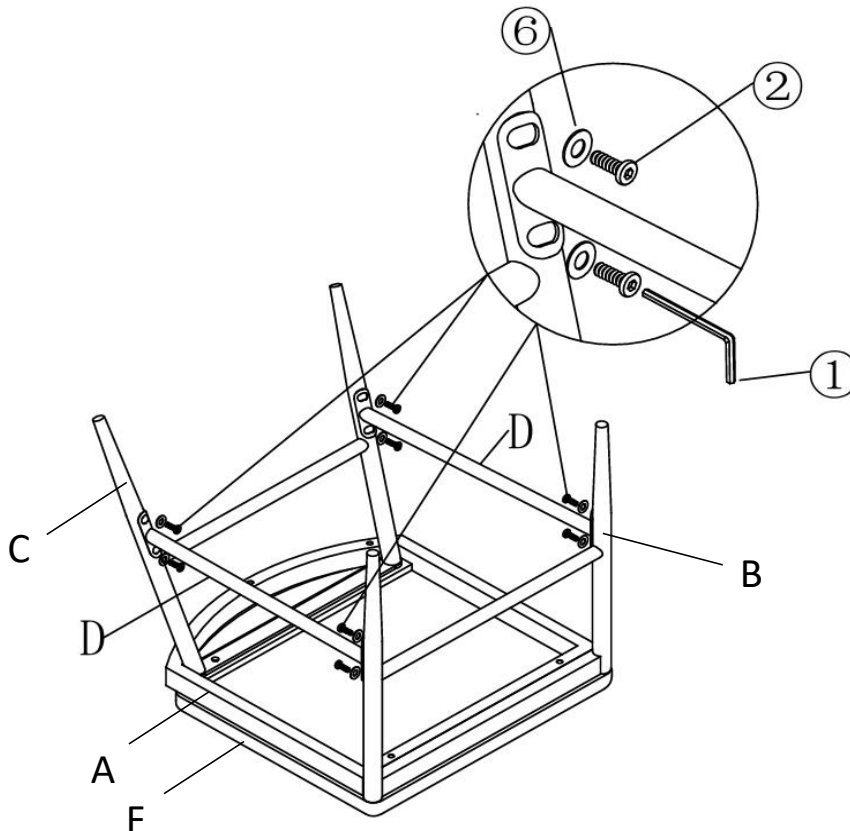

Assemble the Legs Connection Pole (D) using Bolts (②) and Washer (⑥) with Allen Wrench(①) as shown above.

DO NOT FULLY TIGHTEN THE BOLTS.

Assemblez le poteau de connexion de jambes (D) à l'aide de boulons (②) et de rondelles (⑥) avec la clé Allen (①) comme indiqué ci-dessus.

Ne pas serrer complètement les boulons.

Step 6 Étape 6

⑤ × 3

⑥ × 3

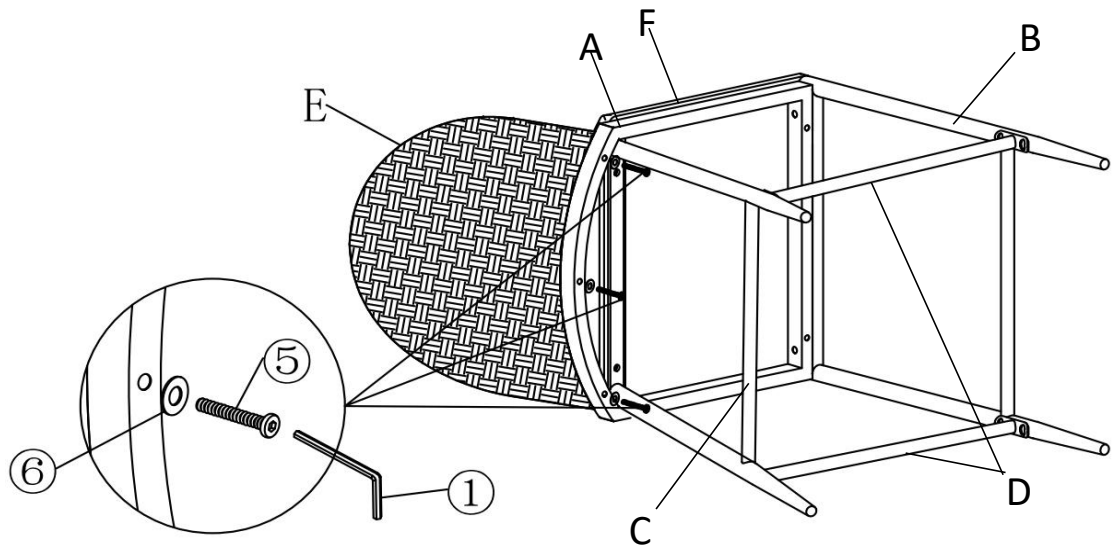

Turn over part of step 2 with the assistant of your adult partner.
Attach the Back Rest (E) to the Seat Panel (C) using Bolts(⑤) and Washer (⑥) with Allen Wrenc(①).
DO NOT FULLY TIGHTEN THE BOLTS.

Retournez une partie de l'étape 2 avec l'assistant de votre partenaire adulte.
Fixez le dossier (E) au panneau de siège (C) à l'aide de boulons (⑤) et de rondelle (⑥) avec la clé Allen (①).
Ne pas serrer complètement les boulons.

Step 7 Étape 7

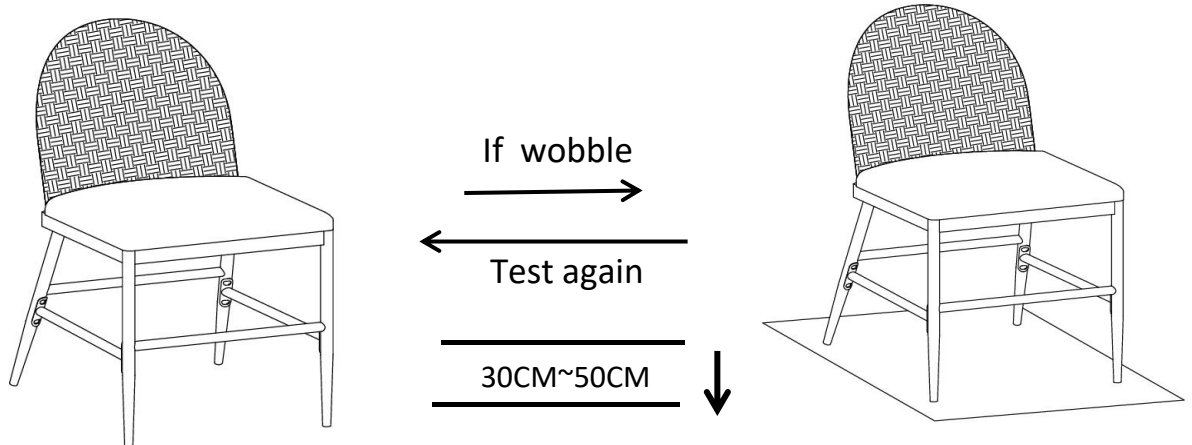

Place the Dining Chair on a **LEVEL SURFACE** to check for wobbles.
If it wobbles, lift the Dining Chair to some 30cm to 50cm in height from the ground.
Keep your feet and toes well away from the drop zone.
Drop the Dining Chair freely and vertically with the four legs, hitting the ground, all at the same time.
This Drop Test will help to ensure that all the bolts and gaps all reach full alignment status.
Test again for evenness on a **LEVEL SURFACE**.
If no wobbles are found, slowly and steadily turn the Dining Chair upside down.
Then, proceed to tighten all bolts in a sequential manner.

CAUTION: When tightening these bolts, tighten sequentially.
DO NOT tighten any screw fully and then towards the next one.
This would cause the frame to warp.
If there is still wobbles, loosen the bolts and execute these same drop tests.
WARNING!! IF Dining CHAIR IS NOT STABLE, IT COULD LEAD TO DAMAGING THE PRODUCT.

Step 8
Étape 8

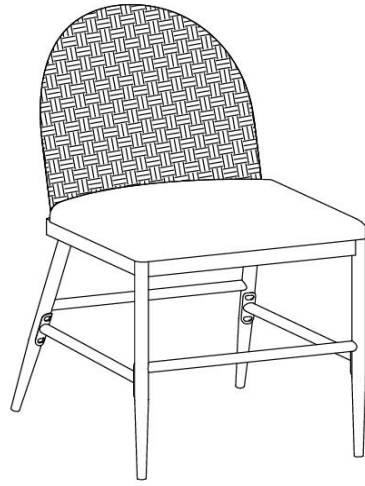

Your Dining Chair is ready for use.

Votre chaise de salle à manger est prête à l'emploi.

Questions & Answers about Proposition 65

- What is Proposition 65?

Proposition 65 requires businesses to provide warnings to Californians about significant exposures to chemicals that cause cancer, birth defects or other reproductive harm. These chemicals can be in the products that Californians purchase, in their homes or workplaces, or that are released into the environment. By requiring that this information be provided, Proposition 65 enables Californians to make informed decisions about their exposures to these chemicals.

Proposition 65 also prohibits California businesses from knowingly discharging significant amounts of listed chemicals into sources of drinking water.

Proposition 65 requires California to publish a list of chemicals known to cause cancer, birth defects or other reproductive harm. This list, which must be updated at least once a year, has grown to include approximately 900 chemicals since it was first published in 1987.

- What types of chemicals are on the Proposition 65 list?

The list contains a wide range of naturally occurring and synthetic chemicals that include additives or ingredients in pesticides, common household products, food, drugs, dyes, or solvents. Listed chemicals may also be used in manufacturing and construction, or they may be byproducts of chemical processes, such as motor vehicle exhaust.

- What does a warning mean?

If a warning is placed on a product label or posted or distributed at a workplace, a business, or in rental housing, the business issuing the warning is aware or believes that it is exposing individuals to one or more listed chemicals.

By law, a warning must be given for listed chemicals unless the exposure is low enough to pose no significant risk of cancer or is significantly below levels observed to cause birth defects or other reproductive harm.

- Where can I get more information on Proposition 65?

If you have specific questions on the administration or implementation of Proposition 65, you can contact OEHHA's Proposition 65 program at P65.Questions@oehha.ca.gov, or by phone at (916) 445-6900.

ASSEMBLY INSTRUCTIONS

INSTRUCTIONS DE MONTAGE

N762P396360 – TABLE / TABLEAU

IMPORTANT NOTE / NOTE IMPORTANTE:

** PLACE ALL PARTS ON A CLEAN AND SMOOTH SURFACE SUCH AS A RUG OR CARPET TO AVOID THE PARTS FROM BEING SCRATCHED.

** PLACEZ TOUTES LES PIÈCES SUR UNE SURFACE PROPRE ET LISSE COMME UN TAPIS OU UNE MOQUETTE POUR ÉVITER QUE LES PIÈCES SOIENT RAYÉES.

** BEFORE YOU BEGIN, KINDLY FOLLOW THE ASSEMBLY INSTRUCTIONS STEP BY STEP.



** AVANT DE COMMENCER, VEUILLEZ SUIVRE LES INSTRUCTIONS D'ASSEMBLAGE ÉTAPE PAR ÉTAPE.

** DO NOT TIGHTEN ALL SCREWS AND BOLTS UNTIL THE TABLE IS FULLY SET-UP.

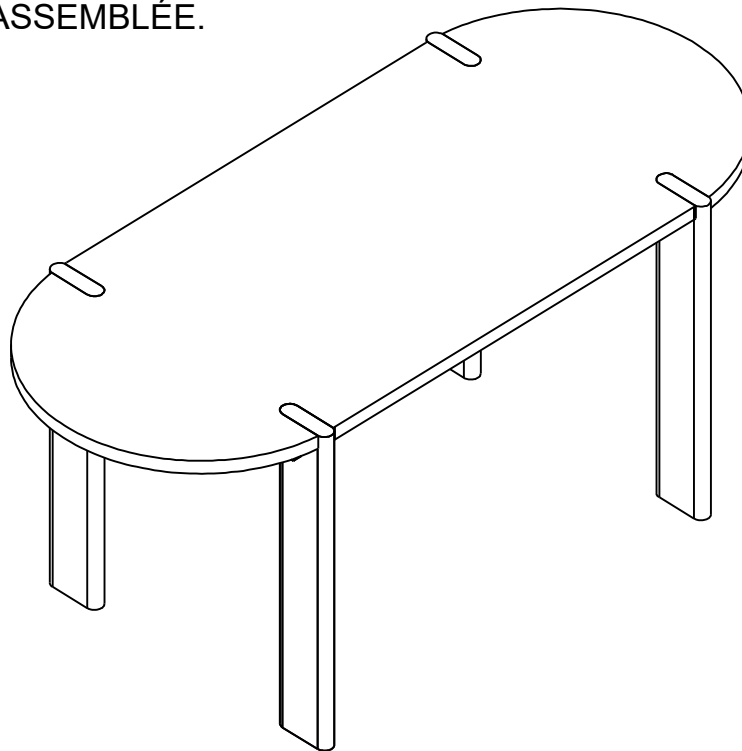

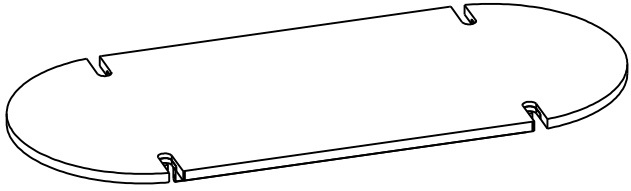

** NE SERREZ PAS TOUTES LES VIS ET TOUS LES BOULONS AVANT QUE LA TABLE NE SOIT ENTIÈREMENT ASSEMBLÉE.

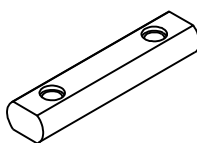

Parts List

Label	Picture	Description	QTY
A		TOP / HAUT	1
B		LEG / JAMBE	2
C		LEG / JAMBE	2
D		SUPPORT BAR / BARRE DE SUPPORT	4

Hardware

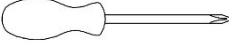
Label	Picture	Description	QTY
1		Bolt / Boulon (M6x75mm)	5
2		Barrel nut / Écrou de barillet (6 x 13mm)	5
3		Bolt / Boulon (M8x35mm)	9
4		ALLEN KEY WRENCH / CLÉ ALLEN	1
5		ASSEMBLY TOOLS REQUIRED (NOT INCLUDED)	

Assembly Preparation

Before Beginning Assembly:

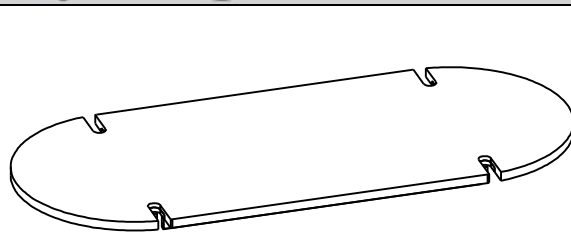

(A)

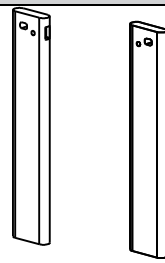

(Bx2)

(Cx2)



(Dx4)

- ① (X 4)
- ② (X 4)
- ③ (X 8)
- ④ (X 1)



- Read instructions, cover to cover-



- Have 2 adults on hand for assembly-



- Do not assemble on flooring or carpet-



- Assemble on a clean non-marring surface (packing foam)-



- Save all packaging until finished-

Assembly Steps

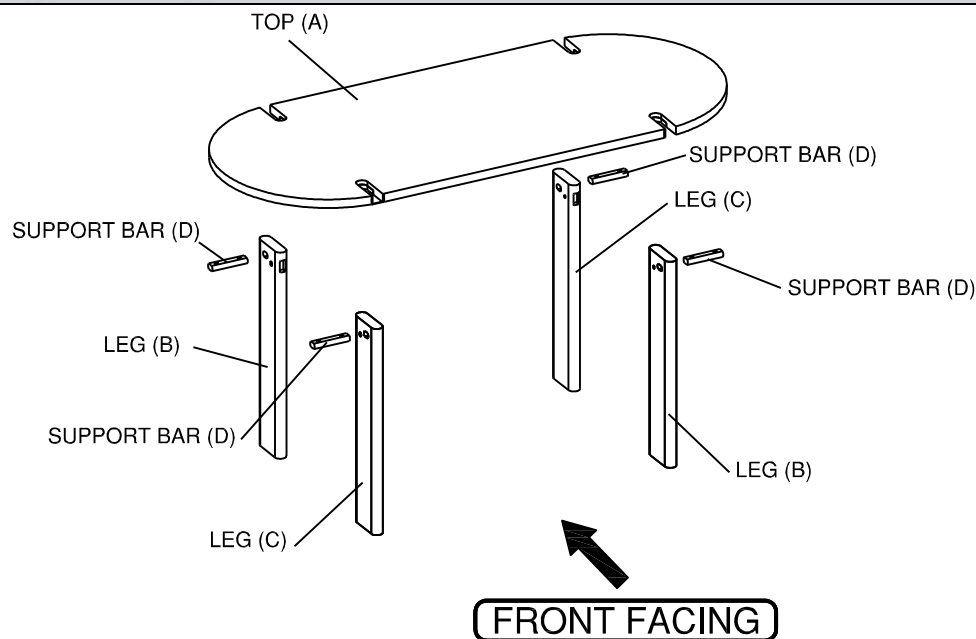

This chair has multiple parts and may require up to 15 minutes to assemble. The picture above provides an overview of the chair parts to help you visualize and understand each component. Please read through the instructions below to familiarize yourself with the parts and steps before assembly.

Cette chaise comporte plusieurs pièces et son assemblage peut prendre jusqu'à 15 minutes.

L'image ci-dessus présente les différentes pièces de la chaise afin de vous aider à visualiser et à comprendre chaque composant. Veuillez lire attentivement les instructions ci-dessous pour vous familiariser avec les pièces et les étapes avant le montage.

Step 1

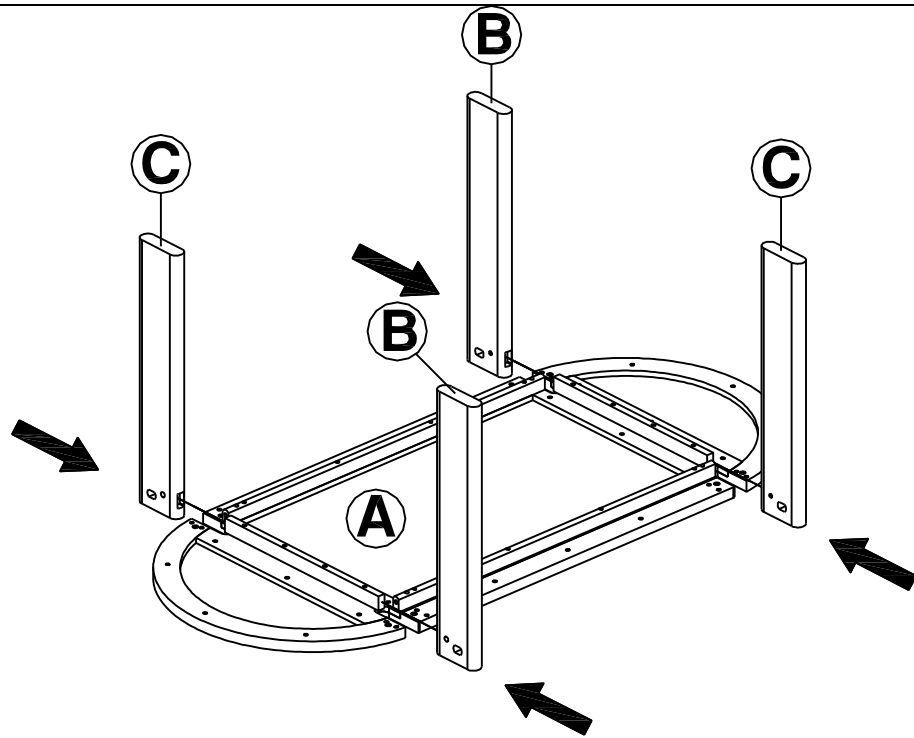

Step 1: Attach the two table legs (B, C) to the table frame (A)

Étape 1: Fixez les deux pieds de table (B, C) au cadre de table (A)

STEP 2

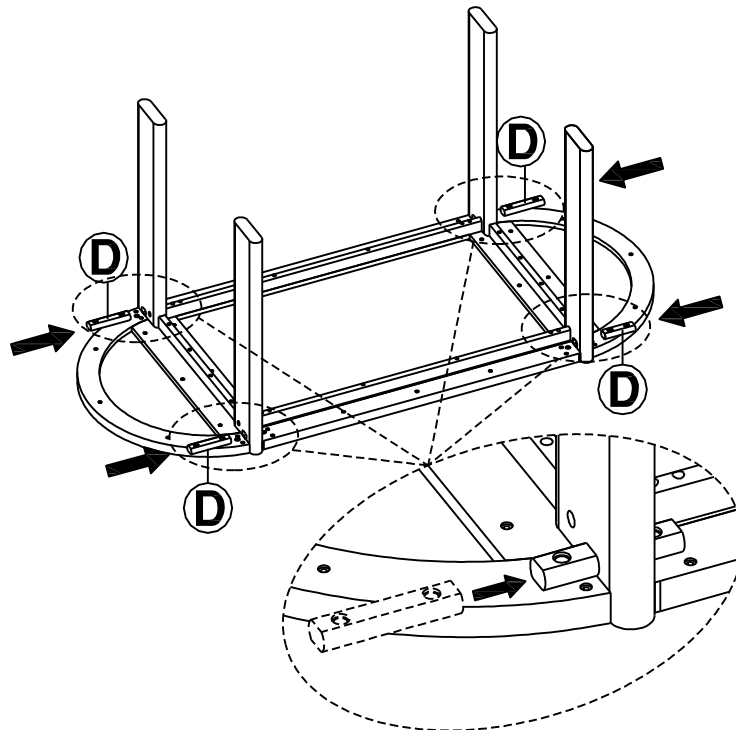

Step 2: Attach Support bar (D) to the legs frame (B,C)

Étape 2 : Fixez la barre de support (D) au cadre des pieds (B,C)

STEP 3

Step 3.1

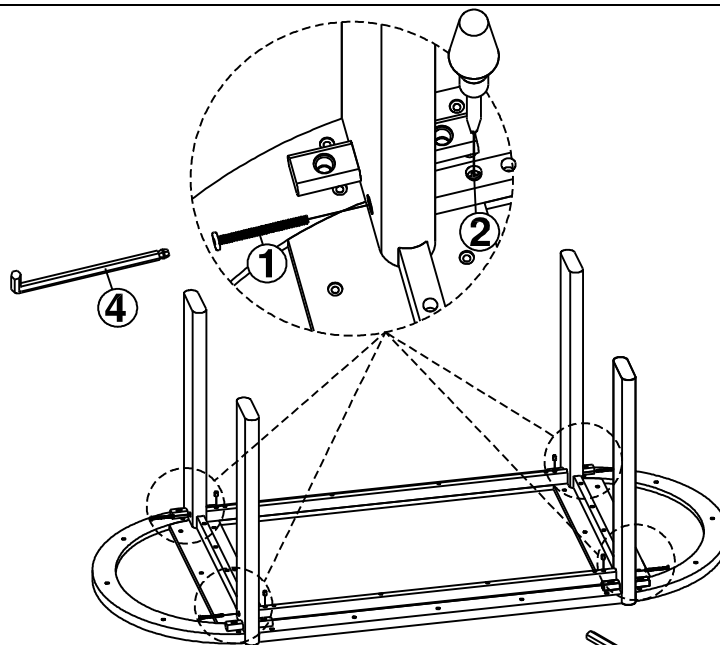

Step 3.2

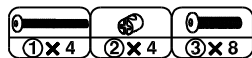
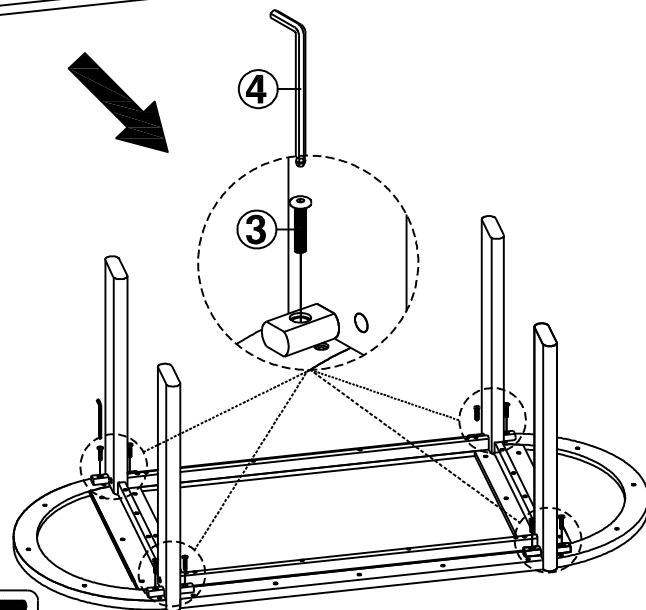

Step 3.1: Install the barrel nut (2) into the round hole on the inside of each table frame, Use screwdriver (5) to fix the barrel nut (2).

Insert the Bolt (1) through the hole on the support bar and thread it into the Barrel Nut and tighten securely with the Allen Wrench (4)

Étape 3.1: Installez l'écrou cylindrique (2) dans le trou rond situé à l'intérieur de chaque cadre de table. Utilisez le tournevis (5) pour le fixer.

Insérez le boulon (1) dans le trou de la barre de support et vissez-le dans l'écrou cylindrique. Serrez-le fermement avec la clé Allen (4).

Step 3.2: Insert the Bolt (3) through the hole on the support bar and tighten securely with the Allen Wrench (4)

Étape 3.2 : Insérez le boulon (3) dans le trou de la barre de support et serrez-le fermement avec la clé Allen (4).

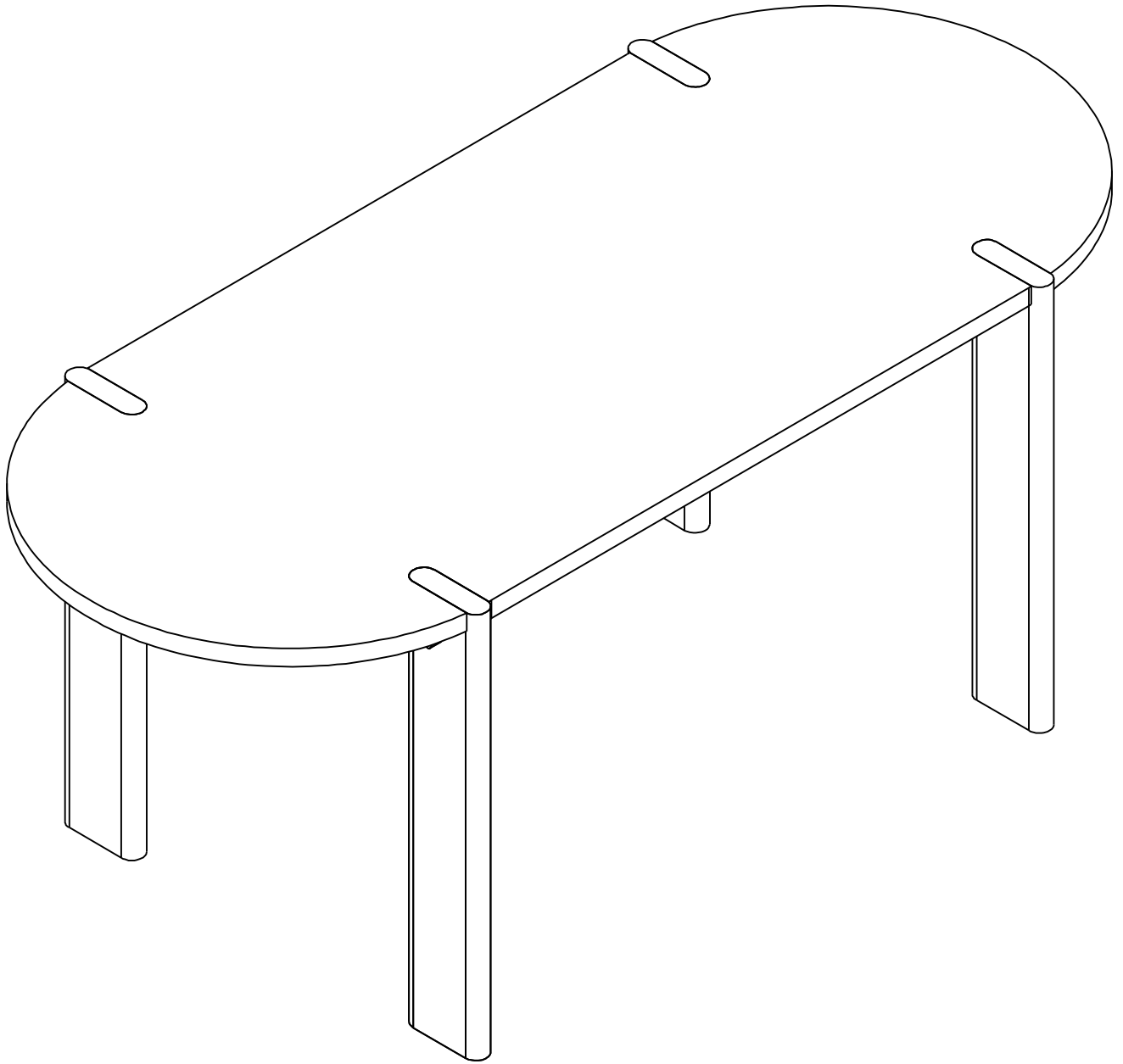

The table is ready for use.

The table can only be used on a flat, level surface.

La table est prête à l'emploi.

Cette table ne peut être utilisée que sur une surface plane et de niveau.