

# CHAMPION

POWER EQUIPMENT™

OWNER'S MANUAL & OPERATING INSTRUCTIONS



## 3 INCH SEMI-TRASH PUMP



MODEL NUMBER  
**66525**

**SAVE THESE INSTRUCTIONS**  
Important Safety Instructions  
are included in this manual.

MADE IN CHINA  
REV 66525-20150116

12039 Smith Ave.  
Santa Fe Springs CA 90670  
USA / 1-877-338-0999  
[www.championpowerequipment.com](http://www.championpowerequipment.com)

**AN IMPORTANT MESSAGE ABOUT TEMPERATURE:**

Your Champion Power Equipment product is designed and rated for continuous operation at ambient temperatures up to 40°C (104°F). When your product is needed your product may be operated at temperatures ranging from -15°C (5°F) to 50°C (122°F) for short periods. If the product is exposed to temperatures outside this range during storage, it should be brought back within this range before operation. In any event, the product must always be operated outdoors, in a well-ventilated area and away from doors, windows and other vents.

**Have questions or need assistance?**

Do not return this product to the store!

**WE ARE HERE TO HELP!**

Visit our website:

**[www.championpowerequipment.com](http://www.championpowerequipment.com)**

for more info:

- Product Info & Updates
- Tech Bulletins
- Frequently Asked Questions
- Product Registration

– or –

Call our Customer Care Team Toll-Free at:

**1-877-338-0999**

**WARNING:**

The Engine Exhaust from this product contains chemicals known to the State of California to cause cancer, birth defects or other reproductive harm.

\*We are always working to improve our products. Therefore, the enclosed product may differ slightly from the image on the cover.

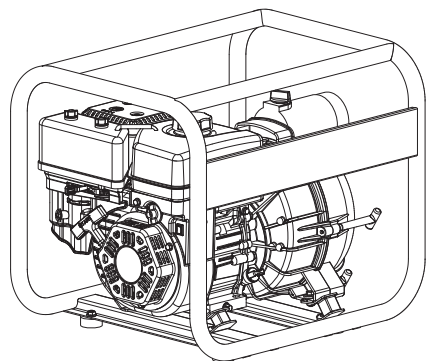

# 3 INCH SEMI-TRASH PUMP

## TABLE OF CONTENTS

<b>Introduction</b> . . . . .	<b>1</b>	Winter Storage . . . . .	12
Introduction . . . . .	1	<b>Specifications</b> . . . . .	<b>13</b>
Semi-Trash Pump . . . . .	1	Engine Specifications . . . . .	13
This Booklet . . . . .	1	Semi-Trash Pump Specifications . . . . .	13
<b>Manual Conventions</b> . . . . .	<b>2</b>	Fuel . . . . .	13
<b>Safety Rules</b> . . . . .	<b>3</b>	Oil . . . . .	13
<b>Controls and Features</b> . . . . .	<b>5</b>	Spark Plugs . . . . .	13
Semi-Trash Pump . . . . .	5	Maintenance Valve Clearance . . . . .	13
Parts Included . . . . .	6	An Important Message About Temperature . . . . .	13
Other . . . . .	6	<b>Troubleshooting</b> . . . . .	<b>14</b>
<b>Assembly</b> . . . . .	<b>7</b>	Parts Diagram . . . . .	15
Remove the Semi-Trash Pump from the Shipping Carton . . . . .	7	Parts List . . . . .	16
Install the Vibration Mounts . . . . .	7	Engine Parts Diagram . . . . .	17
Add Engine Oil . . . . .	7	Engine Parts List . . . . .	18
Add Fuel . . . . .	7	<b>Warranty</b> . . . . .	<b>19</b>
Connecting Hose or Pipes . . . . .	8	Warranty Qualifications . . . . .	19
<b>Operation</b> . . . . .	<b>9</b>	Repair/Replacement Warranty . . . . .	19
Semi-Trash Pump Location . . . . .	9	Do Not Return The Unit To The Place Of Purchase . . . . .	19
Priming the Pump . . . . .	9	Warranty Exclusions . . . . .	19
Starting the Engine . . . . .	9	Normal Wear . . . . .	19
Stopping the Engine . . . . .	10	Installation, Use and Maintenance . . . . .	19
Operation at High Altitude . . . . .	10	Other Exclusions . . . . .	19
<b>Maintenance and Storage</b> . . . . .	<b>11</b>	Limits of Implied Warranty and Consequential Damage . . . . .	19
Engine Maintenance . . . . .	11	Contact Information . . . . .	19
Oil . . . . .	11	Address . . . . .	19
Spark Plugs . . . . .	11	Customer Service . . . . .	19
Air Filter . . . . .	11	Technical Service . . . . .	19
Cleaning . . . . .	12		
Adjustments . . . . .	12		
Maintenance Schedule . . . . .	12		
Storage . . . . .	12		
Engine Storage . . . . .	12		
Semi-Trash Pump Storage . . . . .	12		

# INTRODUCTION

## Introduction

Congratulations on your purchase of a Champion Power Equipment semi-trash pump. CPE designs and builds semi-trash pumps to strict specifications. With proper use and maintenance, this semi-trash pump will bring years of satisfying service.

## Semi-Trash Pump

This unit is a gasoline engine driven, impeller based semi-trash pump. It is designed to pump clear water only.

## This Booklet

Every effort has been made to ensure the accuracy and completeness of the information in this manual. We reserve the right to change, alter and/or improve the product and this document at any time without prior notice.

Record the model and serial numbers as well as date and place of purchase for future reference. Have this information available when ordering parts and when making technical or warranty inquiries.

Champion Power Equipment Support	
1-877-338-0999	
Model Number	
66525	
Serial Number	
Date of Purchase	
Purchase Location	
For <b>Oil Type</b> see 'Add Engine Oil' section. For <b>Fuel Type</b> see 'Add Fuel' section.	

This manual uses the following symbols to help differentiate between different kinds of information. The safety symbol is used with a key word to alert you to potential hazards in operating and owning power equipment.

Follow all safety messages to avoid or reduce the risk of serious injury or death.

 **DANGER**

DANGER indicates an imminently hazardous situation which, if not avoided, **will** result in death or serious injury.

 **WARNING**

WARNING indicates a potentially hazardous situation which, if not avoided, **could** result in death or serious injury.

 **CAUTION**

CAUTION indicates a potentially hazardous situation which, if not avoided, **may** result in minor or moderate injury.

**CAUTION**

CAUTION used without the safety alert symbol indicates a potentially hazardous situation which, if not avoided, **may** result in property damage.

 **NOTE**

If you have questions regarding your semi-trash pump, we can help. Please call our help line at **1-877-338-0999**

# SAFETY RULES

## WARNING

Read this manual thoroughly before operating your semi-trash pump. Failure to follow instructions could result in serious injury or death.

## DANGER

DO NOT pump gasoline and fuel oil mixtures, detergents, acids, chemicals, beverages, pesticides, fertilizers or any other flammable liquid or corrosive.

Pumping volatile liquids may result in an explosion or fire. These liquids will corrode the pump and void your warranty.

## WARNING

The engine exhaust from this product contains chemicals known to the state of California to cause cancer, birth defects, or other reproductive harm.

## DANGER

Engine exhaust contains carbon monoxide, a colorless, odorless, poison gas. Breathing carbon monoxide will cause nausea, dizziness, fainting or death. If you start to feel dizzy or weak, get to fresh air immediately.

Operate semi-trash pump outdoors only in a well ventilated area DO NOT operate the semi-trash pump inside any building, enclosure or compartment.  
DO NOT allow exhaust fumes to enter a confined area through windows, doors, vents or other openings.

## WARNING

Running engines produce heat. Severe burns can occur on contact.  
Combustible material can catch fire on contact.

DO NOT touch hot surfaces.  
Avoid contact with hot exhaust gases.  
Allow equipment to cool before touching.  
Maintain at least 3 ft. (91.4 cm) of clearance on all sides to ensure adequate cooling.  
Maintain at least 5 ft. (1.5 m) of clearance from combustible materials.

## DANGER

Rotating parts can entangle hands, feet, hair, clothing and/or accessories.  
Traumatic amputation or severe laceration can result.

Keep hands and feet away from rotating parts. Tie up long hair and remove jewelry. Operate equipment with guards in place. DO NOT wear loose-fitting clothing, dangling drawstrings or items that could become caught.

## DANGER

The semi-trash pump develops powerful force.

DO NOT move the semi-trash pump when it is in use. DO NOT use hoses or connectors that are worn, damaged or frayed. DO NOT allow children or unqualified persons to operate or service the semi-trash pump. DO NOT open top plug or drain plug.

## WARNING

DO NOT immerse this unit in water.

## WARNING

Sparks can result in fire or electrical shock.

### **When servicing the semi-trash pump:**

Disconnect the spark plug wire and place it where it cannot contact the plug. DO NOT check for spark with the plug removed. Use only approved spark plug testers.

## WARNING

Do not pump any materials (chemical, hazardous, or otherwise) in the direction of any water supply. This may cause contamination and/or unsafe water conditions.

## WARNING

Do not pump any materials (chemical, hazardous, or otherwise) in the direction of any person, animal, or plant life, as this may cause serious damage, injury or death.

**⚠ DANGER**

Fuel and fuel vapors are highly flammable and extremely explosive.  
Fire or explosion can cause severe burns or death.  
Unintentional startup can result in entanglement, traumatic amputation or laceration.

**When adding or removing fuel:**

Turn the engine off and let it cool for at least two minutes before removing the fuel cap. Loosen the cap slowly to relieve pressure in the tank.  
Only fill or drain fuel outdoors in a well-ventilated area.  
DO NOT pump gas directly into the engine at the gas station. Use an approved container to transfer the fuel to the engine.  
DO NOT overfill the fuel tank.  
Always keep fuel away from sparks, open flames, pilot lights, heat and other sources of ignition.  
DO NOT light or smoke cigarettes.

**When starting the engine:**

DO NOT attempt to start a damaged engine. Make certain that the gas cap, air filter, spark plug, fuel lines and exhaust system are properly in place. Allow spilled fuel to evaporate fully before attempting to start the engine.  
Make certain that the semi-trash pump is resting firmly on level ground.

**When operating the semi-trash pump:**

DO NOT move or tip the semi-trash pump during operation.  
DO NOT tip the semi-trash pump or allow fuel or oil to spill from the engine. Block the wheels to prevent unintended movement.

**When transporting or servicing the semi-trash pump:**

Make certain that the fuel shutoff valve is in the off position and the fuel tank is empty.  
Disconnect the spark plug wire.

**When storing the semi-trash pump:**

Store away from sparks, open flames, pilot lights, heat and other sources of ignition.

**⚠ WARNING**

Water pumped through this unit shall NOT be used as drinking water.

**⚠ WARNING**

DO NOT pump salt, sludge, sewer, sea, or any other type of water containing solid material.

**⚠ WARNING**

Rapid retraction of the starter cord will pull hand and arm towards the engine faster than you can let go.  
Unintentional startup can result in entanglement, traumatic amputation or laceration.  
Broken bones, fractures, bruises or sprains could result.

When starting engine, pull the starter cord slowly until resistance is felt and then pull rapidly to avoid kickback.

**⚠ CAUTION**

Exceeding the semi-trash pump's specification for maximum head can damage the semi-trash pump and/or hose kits connected to it.

DO NOT modify the semi-trash pump in any way. DO NOT attempt to exceed the rated flow.  
Attempting to increase the rated flow may damage the unit and/or shorten its life.

**⚠ CAUTION**

Improper treatment or use of the semi-trash pump can damage it, shorten its life and void your warranty.

Use the semi-trash pump only for intended uses.  
Operate only on level surfaces. DO NOT expose semi-trash pump to excessive moisture, dust, or dirt.  
DO NOT allow any material to block the cooling slots.  
DO NOT use the semi-trash pump if:

- Equipment sparks, smokes or emits flames
- Equipment vibrates excessively

**CAUTION**

Lay sturdy planking along each side of the hose or pipe, when the hose or pipe runs across any type of roadway. Make sure that the planking length will run the length of the roadway. This will ensure some protection of the hose or pipe from any passing vehicles.

# CONTROLS AND FEATURES

Read this owner's manual before operating your semi-trash pump. Familiarize yourself with the location and function of the controls and features. Save this manual for future reference.

## Semi-Trash Pump

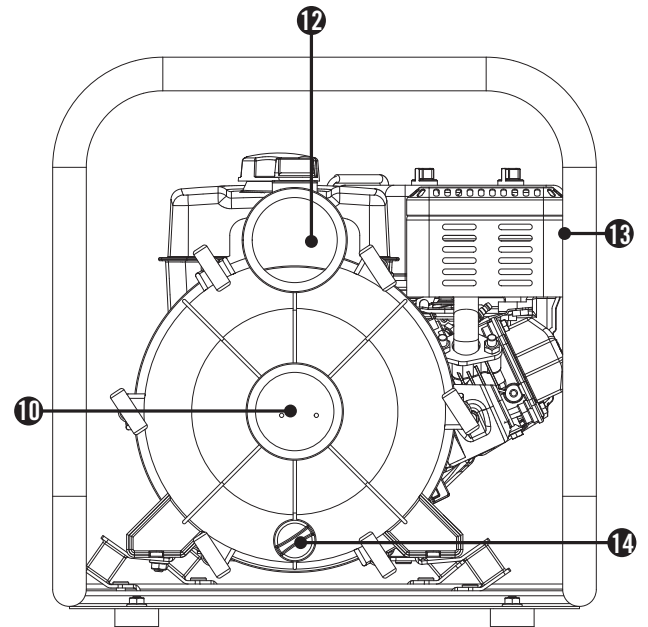
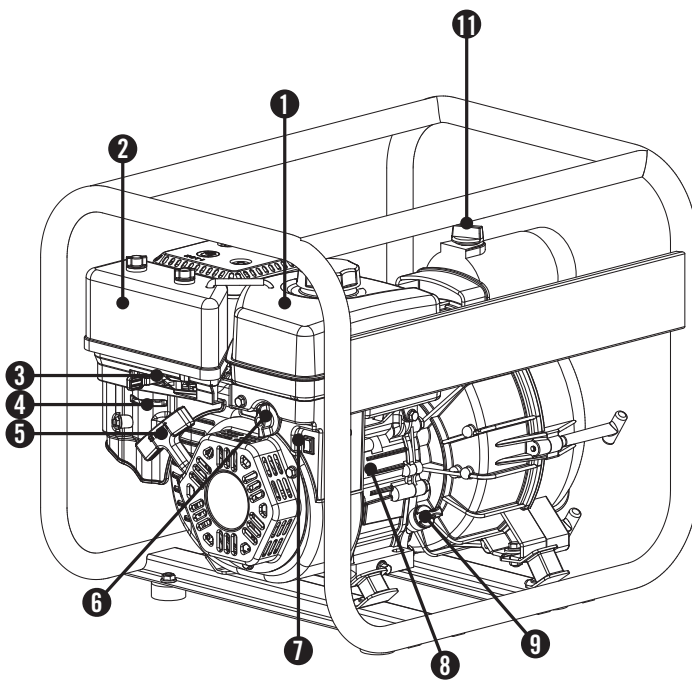

- (1) **Fuel Tank** – 0.9 gal. (3.4 L) capacity fuel tank.
- (2) **Air Filter** – Protects the engine by filtering dust and debris from the air intake.
- (3) **Throttle Lever** – Used to adjust engine speed.
- (4) **Choke Lever** – Used to start the engine.
- (5) **Recoil Starter** – Used to start the engine.
- (6) **Fuel Valve** – Used to turn fuel supply on and off to engine.
- (7) **Engine Switch** – Used to start the engine.
- (8) **Low Oil Sensor** – Senses the level of oil in the crankcase and shuts the engine down if the level falls too low.
- (9) **Oil Filler Cap** – Check and fill engine oil level.
- (10) **3 in. (7.6 cm) Inlet** – 3 in. (7.6 cm) NPT inlet connector.
- (11) **Prime Plug** – Used to prime the pump.
- (12) **3 in. (7.6 cm) Outlet** – 3 in. (7.6 cm) NPT outlet connector.
- (13) **Muffler**
- (14) **Drain Plug**

## Parts Included

Your model 66525 gasoline powered chemical pump ships with the following parts:

### Other

- Vibration Mounts . . . . . 4
- Flange Bolt M8x20 . . . . . 4
- Lock Nut (M8) . . . . . 4
- Spark Plug Socket . . . . . 1
- Oil Funnel . . . . . 1

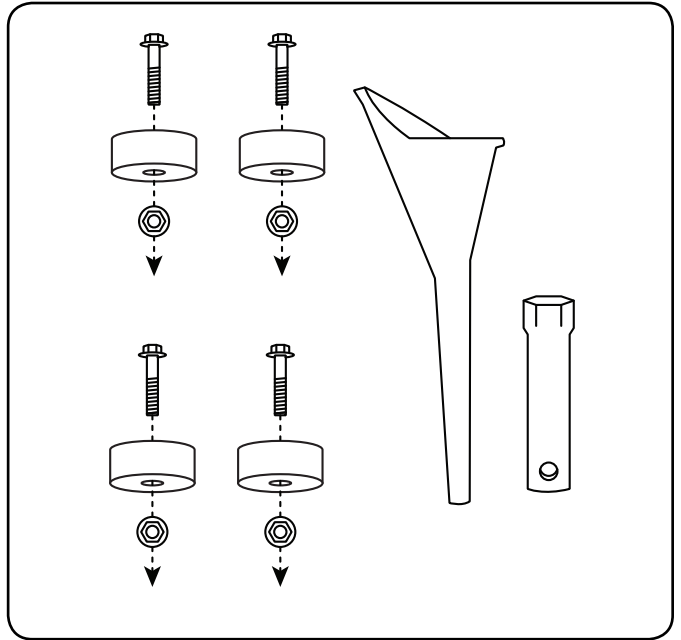

# ASSEMBLY

Your semi-trash pump requires some assembly. This unit ships from our factory without oil. It must be properly serviced with fuel and oil before operation.

If you have any questions regarding the assembly of your semi-trash pump, call our help line at 1-877-338-0999. Please have your serial number and model number available.

## Remove the Semi-Trash Pump from the Shipping Carton

1. Set the shipping carton on a solid, flat surface.
2. Remove everything from the carton except the semi-trash pump.
3. Carefully cut each corner of the box from top to bottom.

## Install the Vibration Mounts

1. Thread the flange bolt (M8x20) through the vibration mount and then through the frame.
2. Firmly secure the bolt to the frame with the M8 nut. Tighten. DO NOT over tighten.
3. Repeat steps 1-2 for the remaining mount (4 total).

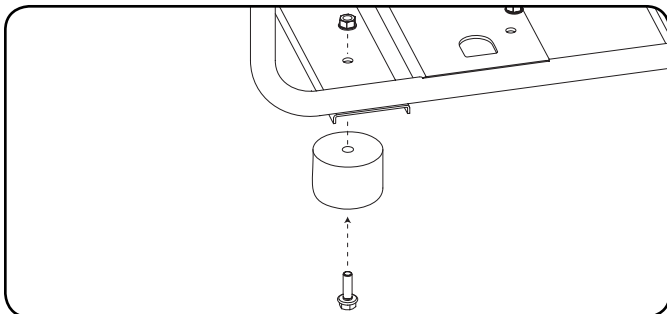

## Add Engine Oil

### ! CAUTION

DO NOT attempt to crank or start the engine before it has been properly filled with the recommended type and amount of oil. Damage to the semi-trash pump as a result of failure to follow these instructions will void your warranty.

### NOTE

The recommended oil type is 10W-30 automotive oil.

## Add Engine Oil Cont'd.

1. Place the semi-trash pump on a flat, level surface.
2. Remove oil fill cap/dipstick to add oil.
3. Add up to 0.6 qt. (0.6 L) of oil and replace oil fill cap/dipstick. DO NOT OVERFILL.
4. Check engine oil level daily and add as needed.

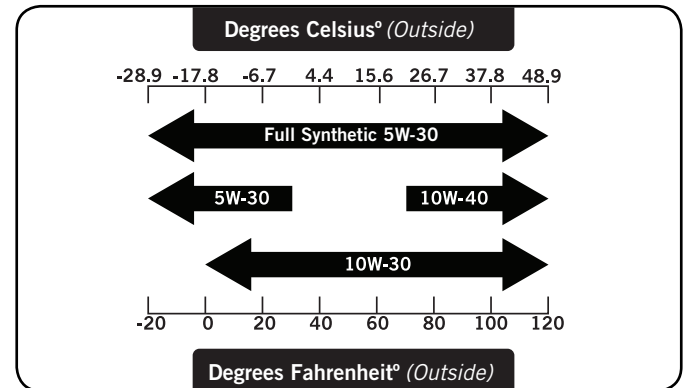

### NOTE

Check oil often during the break-in period. Refer to the Maintenance section for recommended service intervals.

### CAUTION

The engine is equipped with a low oil shut-off and will stop when the oil level in the crankcase falls below the threshold level.

## Add Fuel

1. Use clean, fresh, regular unleaded fuel with a minimum octane rating of 85 and an ethanol content of less than 10% by volume.
2. DO NOT mix oil with fuel.
3. Clean the area around the fuel cap.
4. Remove the fuel cap.
5. Slowly add fuel to the tank. DO NOT OVERFILL. Fuel can expand after filling. A minimum of ¼ in. (6.4 mm) of space left in the tank is required for fuel expansion, more than ¼ in. (6.4 mm) is recommended. Fuel can be forced out of the tank as a result of expansion if it is overfilled, and can affect the stable running condition of the product. When filling the tank, it is recommended to leave enough space for the fuel to expand.
6. Screw on the fuel cap and wipe away any spilled fuel.

## Add Fuel Cont'd.

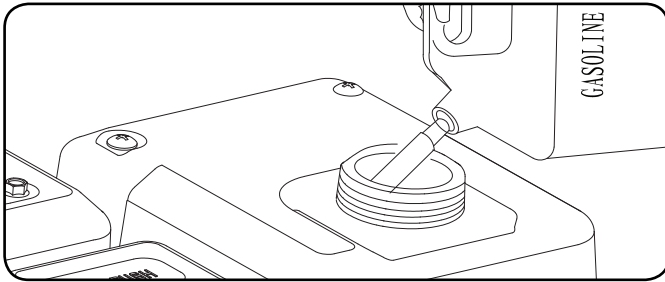

**⚠ WARNING**

Pouring fuel too fast through the fuel screen may result in blow back of fuel at the operator while filling.

**⚠ CAUTION**

Use regular unleaded gasoline with a minimum octane rating of 85.

- Do not mix oil and gasoline.
- Fill tank to approximately  $\frac{1}{4}$  in. (6.4 mm) below the top of the tank to allow for fuel expansion.
- DO NOT pump gas directly into the generator at the gas station. Use an approved container to transfer the fuel to the generator.
- DO NOT fill fuel tank indoors.
- DO NOT fill fuel tank when the engine is running or hot.
- DO NOT overfill the fuel tank.
- DO NOT light cigarettes or smoke when filling the fuel tank.

**NOTE**

Our engines work well with 10% or less ethanol blend fuels. When using blended fuels there are some issues worth noting:

- Ethanol-gasoline blends can absorb more water than gasoline alone.
- These blends can eventually separate, leaving water or a watery goo in the tank, fuel valve and carburetor.
- With gravity-fed fuel supplies, this compromised fuel can be drawn into the carburetor and cause damage to the engine and/or potential hazards.
- There are only a few suppliers of fuel stabilizer that are formulated to work with ethanol blend fuels.
- Any damages or hazards caused by using improper fuel, improperly stored fuel, and/or improperly formulated stabilizers, are not covered by manufacture's warranty.

It is advisable to always shut off the fuel supply, run the engine to fuel starvation and drain the tank when the equipment is not in use for more than 30 days.

### Connecting Hose or Pipes

Hoses or pipes can be connected to the pump using 3 in. (7.6 cm) NPT pipe fittings.

Teflon tape is required to ensure a liquid tight seal. Do not connect rigid pipe directly to the pump as this can cause excess stress that can damage the pump. Always use at least 12 in. (30.5 cm) of flexible hose between the pump and any rigid piping.

# OPERATION

## Semi-Trash Pump Location

Place the semi-trash pump in a well ventilated area. DO NOT place the semi-trash pump near vents or intakes where exhaust fumes could be drawn into occupied or confined spaces. Carefully consider wind and air currents when positioning semi-trash pump.

This semi-trash pump must have at least 5 ft. (1.5 m) of clearance from combustible material. Leave at least 3 ft. (91.4 cm) of clearance on all sides of the semi-trash pump to allow for adequate cooling, maintenance and servicing.

Place the pump on a level surface free from any obstructions or potential hazards. The pump should be placed close to the water level to ensure maximum pump performance.

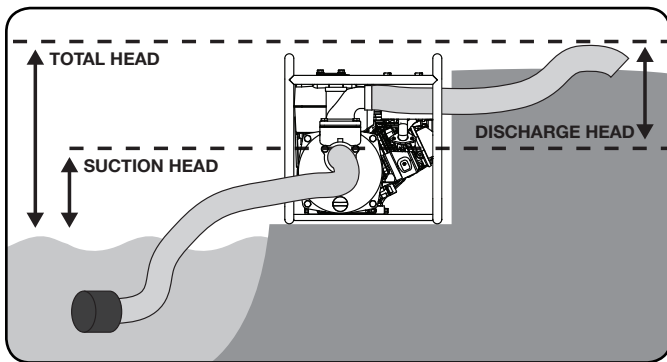

Pump output will be affected by the type, length, and size of the suction and discharge hoses. The pumping height, also known as the total head, is the distance from the water level to the point of discharge. As this distance increases, pump output decreases. The discharge capacity is greater than the suction capacity. Therefore, it is important that the suction head is less than the discharge head.

The time required to draw water from the source to the pump (self-priming time) can be decreased by minimizing the suction head.

### WARNING

**DO NOT** run the pump dry.

Running the pump dry can destroy the pump seals and will void the warranty. If the pump was running while dry, stop the engine and allow it to cool thoroughly before filling the chamber with water.

## Priming the Pump

1. Remove the Pump Priming Plug (#15)
2. Completely fill the pump with liquid.
3. Replace the Pump Priming Plug

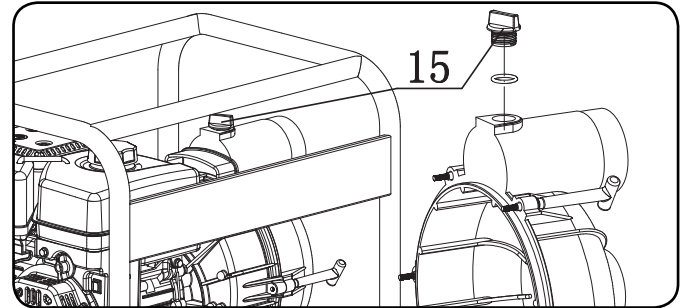

## Starting the Engine

1. Make certain the semi-trash pump is on a flat, level surface.
2. Flip engine switch (A) to "ON" position.
3. Rotate the fuel valve (B) to the "ON" position.
4. Move the choke lever (C) to the "Choke" position.
5. Move throttle lever to middle position. (D)
6. Pull the starter cord slowly until resistance is felt and then pull rapidly.
7. As engine warms up, move the choke lever (C) to "Run".
8. Move the throttle lever (D) to the "Fast" position.

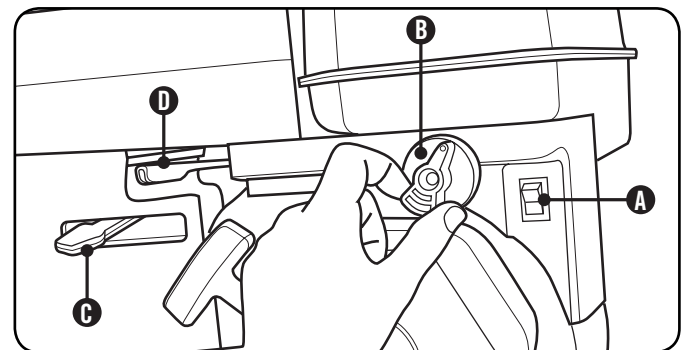

### NOTE

If the engine starts but does not run make certain that the semi-trash pump is on a flat, level surface. The engine is equipped with a low oil sensor that will prevent the engine from running when the oil level falls below a critical threshold.

### NOTE

Keep choke lever in "Choke" position for 2 pulls of the recoil starter. After 2 pulls, move choke lever to the "Run" position for up to the next 3 pulls of the recoil starter. Too much choke leads to spark plug fouling/engine flooding due to the lack of incoming air. This will cause the engine not to start.

## Starting the Engine Cont'd.

### NOTE

Pump performance can be adjusted using the throttle. To decrease pump output, slide the throttle to the right. To increase it, slide the throttle to the left.

### WARNING

**DO NOT** remove either top, or drain (bottom) plugs while the semi-trash pump is on and running

Loss of pressure and suction will occur. Injury may also occur.

## Stopping the Engine

1. Turn the fuel valve to the "OFF" position.
2. Let the engine run until fuel starvation has stopped the engine. This usually takes a few minutes.
3. Move the throttle lever to slow position.
4. Press the engine switch to the "OFF" position.

**Important:** Always ensure that the Fuel Valve and the Engine Switch are in the "OFF" position when the engine is not in use.

### NOTE

If the engine will not be used for a period of two (2) weeks or longer, please see the Storage section for proper engine and fuel storage.

## Operation at High Altitude

The density of air at high altitude is lower than at sea level. Engine power is reduced as the air mass and air-fuel ratio decrease. Engine power and generator output will be reduced approximately 3½% for every 1000 feet of elevation above sea level. This is a natural trend and cannot be changed by adjusting the engine. At high altitudes increased exhaust emissions can also result due to the increased enrichment of the air fuel ratio. Other high altitude issues can include hard starting, increased fuel consumption and spark plug fouling. To alleviate high altitude issues other than the natural power loss, Champion Power Equipment can provide a high altitude carburetor main jet. The alternative main jet and installation instructions can be obtained by contacting Customer Support. Installation instructions are also available in the Technical Bulletin area of the Champion Power Equipment internet site. The part number and recommended minimum altitude for the application of the high altitude carburetor main jet is listed in the table below.

In order to select the correct high altitude main jet it is necessary to identify the carburetor model. For this purpose, a code is stamped on the side of the carburetor. Select the correct main jet part number corresponding to the carburetor code found on your particular carburetor.

Carburetor Code	Main Jet	Part Number	Altitude
P19-1-H	Standard	26.131017.00.H	3500 Feet (1067 Meters)
	Altitude	26.131017.00.01.H	
P19-1-Z	Standard	26.131017.00.Z	
	Altitude	26.131017.00.01.Z	

### WARNING

Operation using the alternative main jet at elevations lower than the recommended minimum altitude can damage the engine. For operation at lower elevations, the standard main jet must be used. Operating the engine with the wrong engine configuration at a given altitude may increase its emissions and decrease fuel efficiency and performance.

# MAINTENANCE AND STORAGE

The owner/operator is responsible for all periodic maintenance.

## ⚠ WARNING

Never operate a damaged or defective semi-trash pump.

## ⚠ WARNING

Improper maintenance will void your warranty.

## NOTE

Maintenance, replacement, or repair of emission control devices and systems may be performed by any non-road engine repair establishment or individual.

Complete all scheduled maintenance in a timely manner. Correct any issue before operating the semi-trash pump.

## NOTE

For service or parts assistance, contact our help line at **1-877-338-0999**.

## Engine Maintenance

To prevent accidental starting, remove and ground spark plug wire before performing any service.

### Oil

Change oil when the engine is warm. Refer to the oil specification to select the proper grade of oil for your operating environment.

1. Remove the oil drain plug with a 12 mm socket and extension.
2. Allow the oil to drain completely.
3. Replace the drain plug.
4. Remove oil fill cap/dipstick to add oil.
5. Add up to 0.6 qt. (0.6 L) of oil and replace oil fill cap/dipstick. **DO NOT OVERFILL.**
6. Dispose of used oil at an approved waste management facility.

## NOTE

Once oil has been added, a visual check should show oil about 1-2 threads from running out of the fill hole. If using the dipstick to check oil level, **DO NOT** screw in the dipstick while checking.

### Oil Cont'd.

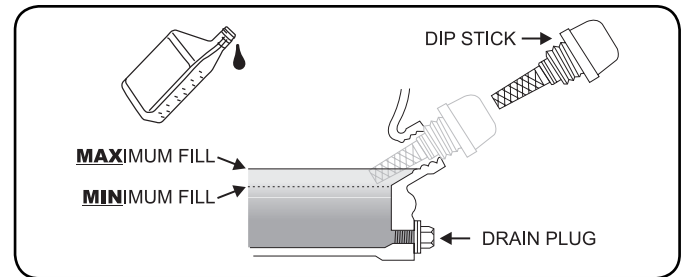

### Spark Plugs

1. Remove the spark plug cable from the spark plug.
2. Use the spark plug tool that shipped with your semi-trash pump to remove the plug.
3. Inspect the electrode on the plug. It must be clean and not worn to produce the spark required for ignition.
4. Make certain the spark plug gap is 0.7 - 0.8 mm or (0.028 - 0.031 in.).

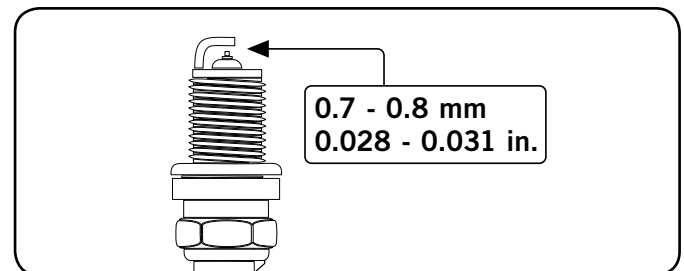

5. Refer to spark plug section on specifications page.
6. Carefully thread the plug into the engine.
7. Use the spark plug tool to firmly install the plug.
8. Attach the spark plug wire to the plug.

### Air Filter

1. Unscrew wing nut to remove the air filter cover.
2. Remove the foam element.
3. Wash in liquid detergent and water. Squeeze thoroughly dry in a clean cloth.
4. Saturate in clean engine oil.
5. Squeeze in a clean, absorbent cloth to remove all excess oil.
6. Reassemble the element.
7. Reattach the air filter cover and tighten wing nut.

## ⚠ CAUTION

**DO NOT** spray engine with water.

Water can contaminate the fuel system.

## Cleaning

Use a damp cloth to clean exterior surfaces of the engine. Use a soft bristle brush to remove dirt and oil. Use an air compressor (25 PSI) to clear dirt and debris from the engine.

## Adjustments

The air-fuel mixture is not adjustable. Tampering with the governor can damage your semi-trash pump and your electrical devices and will void your warranty. CPE recommends that you contact our service line at **1-877-338-0999** for all other service and/or adjustment needs.

## Maintenance Schedule

Follow the service intervals indicated in the following maintenance schedule.

Service your semi-trash pump more frequently when operating in adverse conditions.

Contact our help line at **1-877-338-0999** to locate the nearest Champion Power Equipment certified service dealer for your semi-trash pump or engine maintenance needs.

Every 8 hours or daily	
	Check oil level
	Clean around air intake and muffler
First 5 Hours	
	Change oil
Every 50 hours or every season	
	Clean air filter
	Change oil if operating under heavy load or in hot environments
Every 100 hours or every season	
	Change oil
	Clean/Adjust spark plug
	Check/Adjust valve clearance*
	Clean spark arrester
	Clean fuel tank and filter*
Every 250 hours	
	Clean combustion chamber*
Every 3 years	
	Replace fuel line

\*To be performed by knowledgeable, experienced owners or Champion Power Equipment certified dealers.

## Storage

For longer term storage, please follow these guidelines.

### NOTE

Engine switch should be in the "OFF" position while pulling the recoil cord, and performing storage maintenance steps.

## Engine Stored for Less than 30 Days

1. Allow the engine to cool completely before storage.
2. Clean engine according to the Maintenance section.
3. To extend the fuel storage life add a properly formulated fuel stabilizer to the tank.
4. Ensure the fuel valve is in the "OFF" position.

## Engine Stored for Over 30 Days

1. Add a properly formulated fuel stabilizer to the tank.
2. Run the engine for a few minutes so the treated fuel cycles through the fuel system and carburetor.
3. Turn the fuel valve to the "Off" position.
4. Let the engine run until fuel starvation has stopped the engine. This usually takes a few minutes.
5. The engine needs to cool completely before cleaning and storage.
6. Clean the engine according to the maintenance section.
7. Change the oil.
8. Remove the spark plug and pour about 1/2 ounce (14.8 ml) of oil into the cylinder. Crank the engine slowly to distribute the oil and lubricate the cylinder.
9. Reattach the spark plug.

## Semi-Trash Pump Storage

1. Allow the semi-trash pump to cool completely before storage.
2. Turn off the fuel supply at the fuel valve.
3. Drain the pump chamber thoroughly.
4. Clean the semi-trash pump according to the instructions in the Maintenance section.
5. Once the pump is dry, spray WD-40 or similar product into the pump housing through all ports and drainage hole.
6. Store in a clean, dry place out of direct sunlight.

## Winter Storage

Protect your semi-trash pump parts from freezing.

1. Apply all storage instructions from previous sections.
2. Make sure semi-trash pump hose is free of all water before storing for winter.
3. In order to prevent the pump from freezing you will need to insert RV antifreeze.
4. You will need approximately 6 ounces (177.4 ml) of RV Antifreeze, a funnel, and approximately 12 in. (30.5 cm) of garden hose or equivalent. See diagram below.

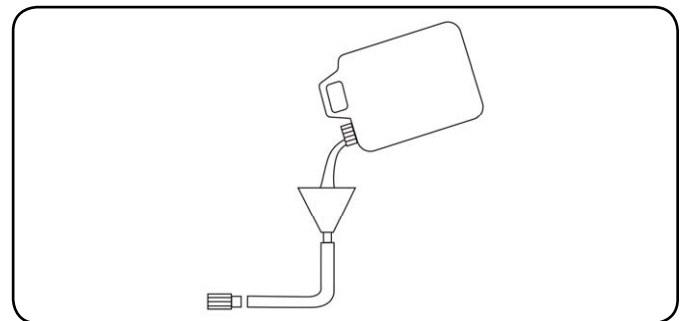

5. Pour the antifreeze into the funnel, then pull on the engine recoil starter to create suction in the pump housing. Pull the recoil several times until antifreeze comes out of the pump outlet.

# SPECIFICATIONS

## Engine Specifications

- Model . . . . . YF168F-2-000
- Displacement . . . . . 196cc
- Type . . . . . 4-Stroke OHV
- Start Type . . . . . Recoil

## Semi-Trash Pump Specifications

- Model . . . . . 66525
- Inlet Diameter . . . . . 3 in. (7.6 cm) NPT
- Outlet Diameter . . . . . 3 in. (7.6 cm) NPT
- Fuel Capacity . . . . . 0.9 gal. (3.4 L)
- Total Head . . . . . 85 ft. (25.9 m)
- Suction Head . . . . . 26 ft. (8 m)
- Max Delivery Volume . . . . . 343 gal/min (1298 L/min)
- Max Solid Waste . . . . . 3/4 in. diameter (1.9 cm)
- Gross Weight . . . . . 97 lb. (44 kg)
- Net Weight . . . . . 84.9 lb. (38.5 kg)
- Height . . . . . 20 in. (50.8 cm)
- Width . . . . . 19 in. (48.5 cm)
- Length . . . . . 23 in. (58.5 cm)

## Fuel

Fuel capacity is 0.9 gal. (3.4 L). Use regular unleaded gasoline with a minimum octane rating of 85 and an ethanol content of no more than 10% by volume.

## Oil

Use 10W-30 automotive oil.

Oil capacity is 0.6 qt. (0.6 L).

DO NOT OVERFILL.

Please reference the following chart for recommended oil types for use in the semi-trash pump.

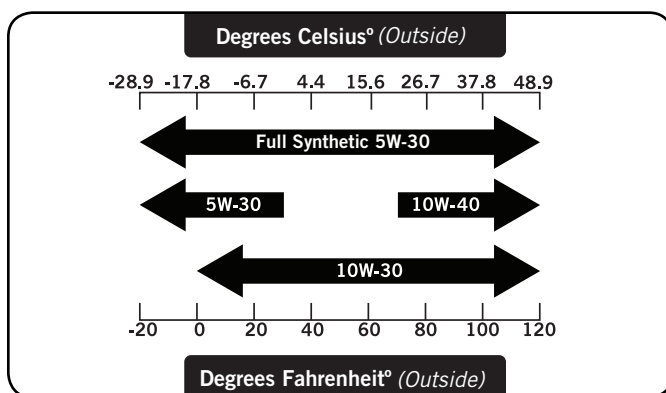

## Spark Plugs

**OEM spark plug:** NHSP F6RTC

**Replacement spark plug:** NGK BPR6ES or equivalent  
Make certain the spark plug gap is 0.7 - 0.8 mm or (0.028 - 0.031 in.).

## Maintenance Valve Clearance

- Intake: 0.13 – 0.17 mm (0.005 – 0.007 in.)
  - Exhaust: 0.18 – 0.22 mm (0.007 – 0.009 in.)
- Note: Tech bulletin regarding the valve adjustment procedure is on [www.championpowerequipment.com](http://www.championpowerequipment.com).

## NOTE

Weather will affect engine oil and engine performance. Change the type of engine oil used based on weather conditions to suit the engine needs.

## An Important Message About Temperature

Your Champion Power Equipment product is designed and rated for continuous operation at ambient temperatures up to 40°C (104°F). When your product is needed your product may be operated at temperatures ranging from -15°C (5°F) to 50°C (122°F) for short periods. If the product is exposed to temperatures outside this range during storage, it should be brought back within this range before operation. In any event, the product must always be operated outdoors, in a well-ventilated area and away from doors, windows and other vents.

Problem	Cause	Solution
Semi-trash pump will not start	No fuel	Add fuel
	Faulty spark plug	Replace spark plug
Semi-trash pump will not start; Semi-trash pump starts but runs roughly	Low oil level	Fill crankcase to the proper level; place semi-trash pump on a flat, level surface
	Choke in the wrong position	Adjust choke
	Spark plug wire loose	Attach wire to spark plug
Semi-trash pump shuts down during operation	Out of fuel	Fill fuel tank
	Low oil level	Fill crankcase to the proper level; place semi-trash pump on a flat, level surface
Semi-trash pump overheating or performing poorly	Strainer or hose clogged	Remove debris from strainer or hose
	Pump not primed	Re-prime pump
	Suction hose out of water	Place suction hose under the surface of the water
	Head limit exceeded	Relocate pump so suction head is less than discharge head (maximum 98 feet)
	Air leak	Tighten connectors and clamps or replace seal packing

### For further technical support:

#### Technical Service

Mon – Fri 8:30 AM – 5:00 PM (PST/PDT)

Toll Free: 1-877-338-0999

tech@championpowerequipment.com

# SPECIFICATIONS

## Parts Diagram

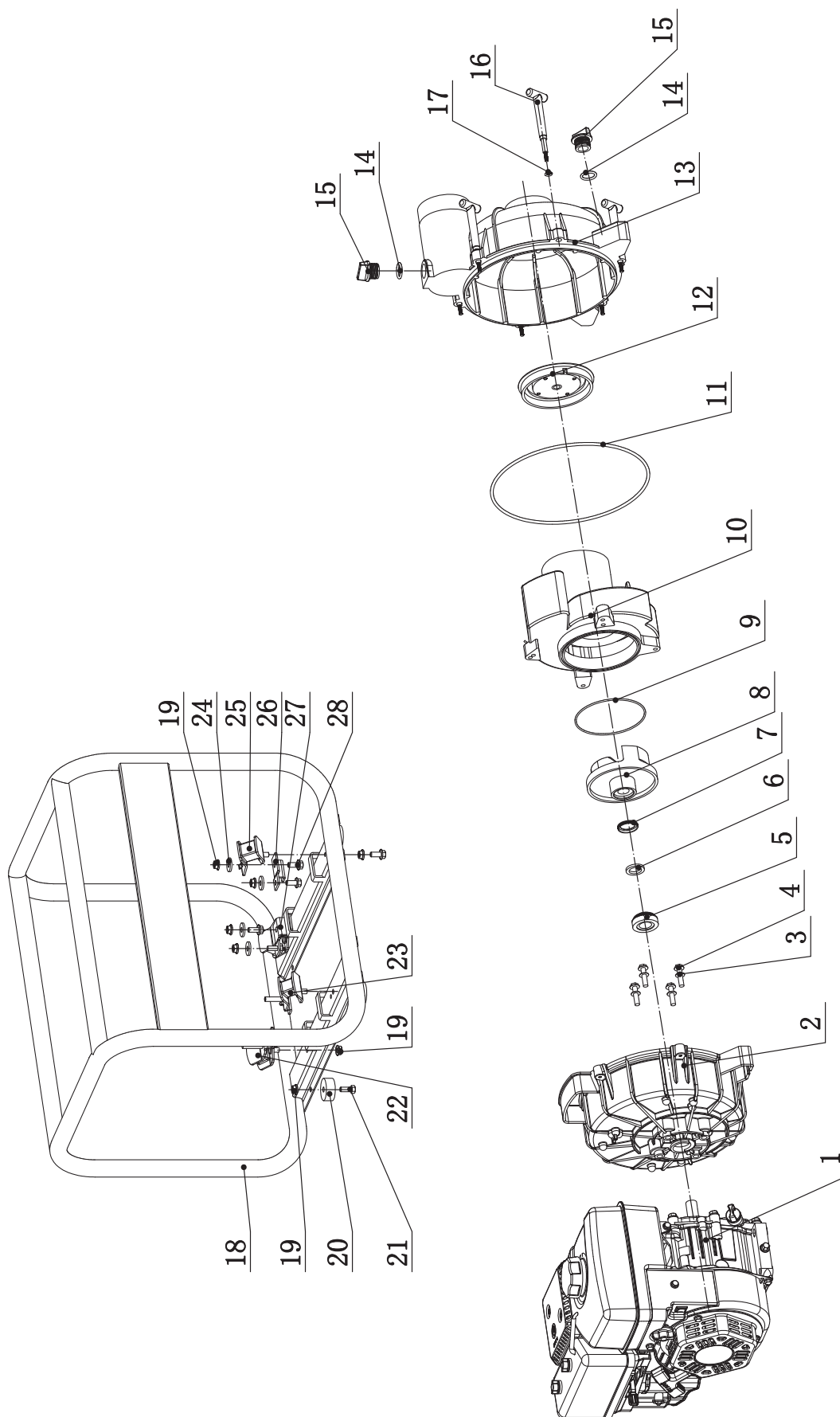

#	Part Number	Description	Qty
1	26.103	Engine	1
2	221.251303.01	Base,Pump	1
3	202.251002.00	Washer Ø8, Copper	4
4	1.5789.0835	Flange Bolt M8×35	4
5	221.250300.01	Water Seal	1
6	221.251301.01	Friction-Piece	1
7	221.251302.01	Seal, Impeller	1
8	221.251106.01	Impeller	1
9	1.3452.1.12503	Seal, Impeller	1
10	221.251202.01	Cover,Impeller Cover	1
11	1.3452.1.26605	Seal,Pump Body	1
12	221.251105.01	Valve,One Way	1
13	221.251101.01	Body,Pump	1
14	1.3452.1.01803	Seal, Plug	2
15	221.251401.01	Plug	2
16	221.251114.01	"T" Bolt	6
17	1.3452.1.00503	Seal,"T" Bolt	6
18	6.1.110.2	Frame	1
19	1.6177.1.08	Nut M8	14
20	203.201400.01	Rubber	4
21	1.5783.0820	Bolt M8×20	4
22	122.201200.05	Motor Mount II	1
23	122.201200.04	Motor Mount I	1
24	1.96.08	Big Washer Ø8	4
25	113.201200.01	Pump Mount	2
26	221.200018.00	Supporter I	1
27	221.200018.01	Supporter II	1
28	1.16674.0820	Flange Bolt M8×20	4

# SPECIFICATIONS

## Engine Parts Diagram

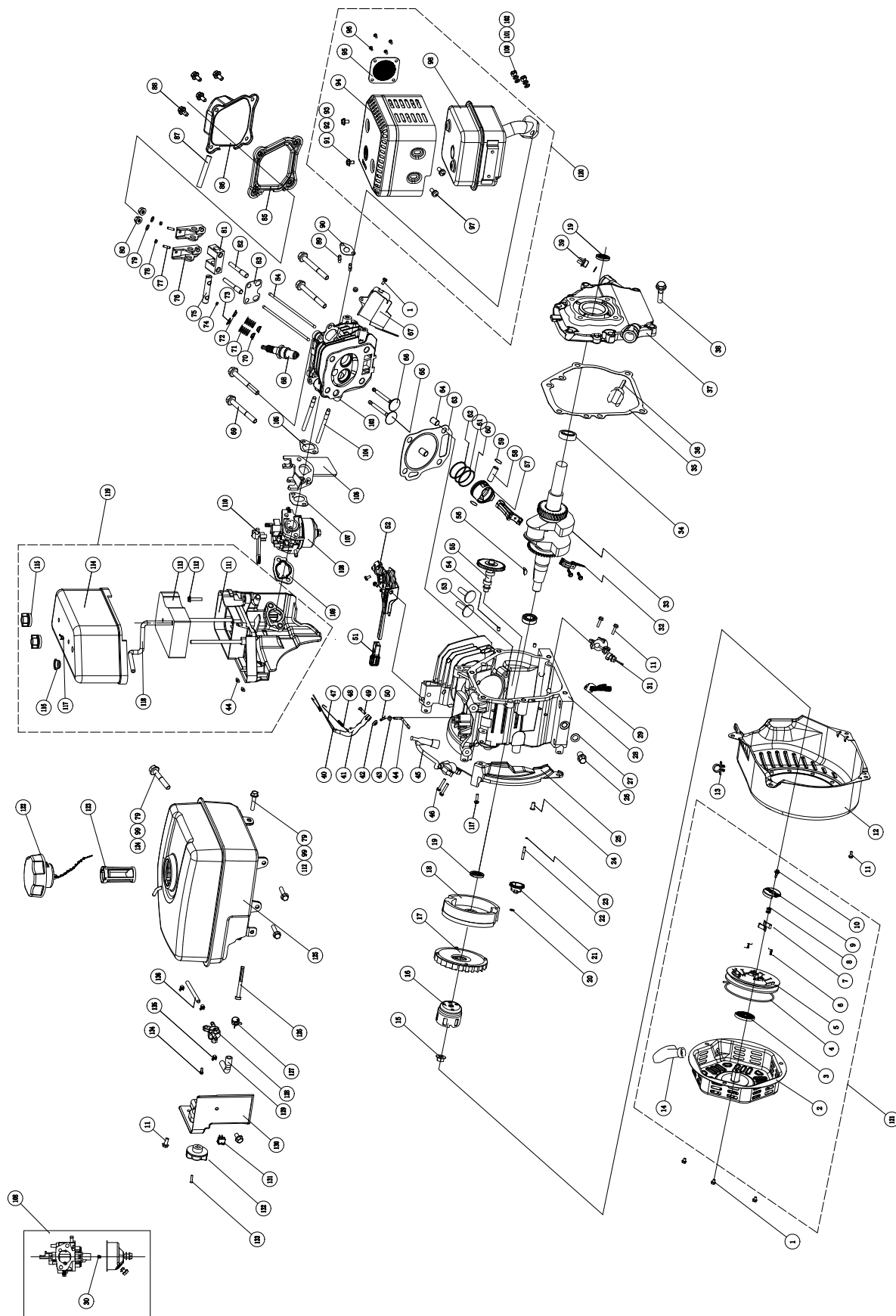

#	Part Number	Description	Qty
1	1.5789.0608	Flange Bolt M6x8	5
2	22.061100.00.2	Recoil Starter Cover, Black	1
3	21.061005.00	Recoil Starter Spring	1
4	2.10.003	Rope (Ø5x1550)	1
5	21.061001.01	Recoil Starter Reel	1
6	45.060003.00	Spring, Ratchet	2
7	45.060002.00	Starter Ratchet (Iron)	2
8	45.060009.00	Spring, Ratchet Guide	1
9	45.060007.00	Ratchet Guide	1
10	45.060008.00	Screw, Ratchet Guide	1
11	1.5789.0612	Flange Bolt M6x12	10
12	24.080100.01.48	Fan Cover, Yellow	1
13	2.05.002	Clamp (Ø9.5x5)	1
14	21.061300.00	Recoil Handle	1
15	2.02.006	Nut (M14x1.5)	1
16	21.060001.01	Pulley, Starter	1
17	23.080001.00	Cooling Fan	1
18	24.120100.06	Flywheel (EPA)	1
19	2.11.001	Oil Seal (Ø25xØ41.3x6)	2
20	2.03.020.1	Washer (Ø6.2xØ15x0.5), Black	1
21	21.110100.00	Gear, Governor	1
22	21.110013.00	Shaft, Governor, Gear	1
23	21.110011.00	Clip, Governor, Gear	1
24	21.110012.01	Bushing, Governor Gear	1
25	23.080600.00	Air Guide, Right	1
26	2.08.037	Drain Bolt(M10x1.25x25)	2
27	2.03.016	Washer, Drain Bolt (Ø10xØ16x1.5)	2
28	26.030100.00	Crankcase	1
29	21.120400.01	Diode Assembly	1
30	26.131017.00	Standard Main Jet	1
	26.131017.00.01	Altitude Main Jet	/
31	21.127000.02	Oil Level Sensor	1
32	23.050200.00	Connecting Rod	1
33	25.050100.02	Crankshaft (P)	1
34	1.276.6205	Bearing 6205	2
35	24.030008.00	Gasket, Crankcase Cover	1
36	22.031000.00	Oil Dipstick Assembly	1
37	24.030007.00	Cover, Crankcase	1
38	1.5789.0832.0.8	Flange Bolt M8x32	6
39	22.031000.01	Oil Filler Cap	1
40	23.110005.01	Spring, Throttle Return	1
41	21.110003.00	Governor Arm	1
42	1.6177.06	Flange Nut M6	3
43	2.03.021.1	Washer (Ø6.4xØ13x1), Black	1
44	21.110001.00	Shaft, Governor Arm	1
45	22.123000.01	Ignition Coil (Shield)	1
46	1.5789.0625	Flange Bolt M6x25	2
47	23.110006.00	Governor Rod	1
48	23.110007.00	Governor Spring	1
49	2.08.040	Bolt, Governor Arm (M6x21)	1
50	21.110008.00	Pin, Shaft	1
51	24.111008.01	Grip Sheath, Speed Governor	1
52	24.111000.01	Control Assembly	1
53	25.040013.00	Lifter, Valve	2
54	2.04.001	Dowel Pin (Ø9x14)	2
55	26.041000.01	Camshaft	1
56	2.14.012	Woodruff Key (4x7.5x19)	1
57	26.050005.00	Piston	1
58	23.050003.00	Pin, Piston	1
59	2.09.001	Circlip (Ø18xØ1)	2
60	26.050303.00	Ring, Oil	1
61	26.050302.00	Ring, Second Piston	1
62	26.050301.00	Ring, First Piston	1
63	26.030009.00	Gasket, Cylinder Head	1
64	2.04.003	Dowel Pin (Ø10x14)	2
65	23.040002.00	Valve, Intake	1
66	23.040006.00	Valve, Exhaust	1
67	26.080400.00	Air Guide, Lower	1
68	2.15.002(F6RTC)	Spark Plug (F6RTC)	1

#	Part Number	Description	Qty
69	1.5789.0855	Flange Bolt M8x55	4
70	23.040017.00	Oil Seal, Valve	2
71	21.040003.00	Spring, Valve	2
72	21.040007.00	Retainer, Exhaust Valve Spring (Up)	1
73	21.040001.00	Retainer, Intake Valve Spring (Up)	1
74	21.040008.00	Rotator, Exhaust Valve	1
75	24.040202.00	Shaft, Rocker Arm	1
76	22.040009.00	Rocker Arm	2
77	22.040012.00	Screw, Valve Adjustment	2
78	21.040021.00	Nut, Lock (M6x0.5)	2
79	1.97.1.06	Washer Ø6	6
80	1.6177.1.06	Flange Lock Nut M6	2
81	24.040201.00	Retainer, Rocker Arm	1
82	23.040010.00	Bolt, Rocker Arm	2
83	24.040004.00	Guide Plate, Push Rod	1
84	23.040005.00	Push Rod	2
85	21.020002.01	Gasket, Cylinder Head Cover (CPE)	1
86	24.021000.00	Cylinder Head Cover (CPE)	1
87	21.020001.00	Breather Tube	1
88	1.5789.0615	Flange Bolt M6x15	4
89	2.01.010	Stud Bolt M8x35	2
90	26.100001.00	Gasket, Exhaust Pipe	1
91	1.16674.0510	Flange Bolt M5x10	2
92	1.848.05	Washer Ø5	2
93	1.93.05	Spring Washer Ø5	2
94	24.101202.00	Muffler Protector	1
95	46.101300.05	Spark Arrester	1
96	1.818.0406	Screw M4x6	4
97	1.9074.4.0510	Screw And Washer Assembly M5x10	2
98	24.101000.00	Muffler	1
99	1.93.06	Lock Washer Ø6	6
100	1.6175.08	Nut M8	2
101	1.848.08	Washer Ø8	2
102	1.93.08	Spring Washer Ø8	2
103	26.010100.00	Cylinder Head	1
104	2.01.009	Stud Bolt (M6x110)	2
105	24.130002.00	Gasket, Insulator	1
106	23.130001.00	Insulator, Carburetor	1
107	22.130003.00	Gasket, Carburetor	1
108	26.131000.00	Carburetor	1
109	21.130004.00	Gasket, Air Cleaner	1
110	21.130100.00	Choke Handle	1
111	24.091100.01	Base, Air Cleaner	1
112	1.5789.0620	Flange Bolt M6x20	5
113	24.091003.02	Element, Air Cleaner	1
114	24.091200.02	Cover, Air Cleaner	1
115	24.091600.01	Screw Cap, Air Clean Cover	2
116	2.12.001	Buffer (Ø7.5x7.5)	1
117	2.06.006	Clip (Ø7xØ1)	1
118	24.070014.02	Pipe, Reversal Valve	1
119	24.091000.02	Air Cleaner Assembly	1
120	24.101000.00	Muffler Assembly	1
121	22.061000.00	Recoil Assembly	1
122	24.070100.02	Fuel Tank Cap	1
123	81.070301.00	Fuel Filter	1
124	1.5789.0633	Flange Bolt M6x33	1
125	24.071000.01	Fuel Tank	1
126	111.070300.01	Fuel Filter Component	1
127	2.06.018	Clip (Ø10.5xb8)	1
128	24.070400.00	Fuel Cock	1
129	24.070011.01	Pipe, Fuel	1
130	24.070010.00	Fuel Tank Veil	1
131	5.1010.003.3	Flameout Switch	1
132	24.070001.00	Fuel Cock Knob	1
133	1.818.0412	Bolt M4x12	1
134	1.16674.0512.2	Flange Bolt M5x12	1
135	2.06.007	Clip (Ø8xb6)	3
136	24.070011.00	Pipe, Fuel	1

# WARRANTY

## WARRANTY

### CHAMPION POWER EQUIPMENT 1 YEAR LIMITED WARRANTY

Effective September 1, 2006. Replaces all undated warranties and all warranties dated before September 1, 2006.

### Warranty Qualifications

Champion Power Equipment (CPE) will register this warranty upon receipt of your Warranty Registration Card and a copy of your sales receipt from one of CPE's retail locations as proof of purchase.

Please submit your warranty registration and your proof of purchase within ten (10) days of the date of purchase.

### Repair/Replacement Warranty

CPE warrants to the original purchaser that the mechanical and electrical components will be free of defects in material and workmanship for a period of one (1) year from the original date of purchase (90 days for commercial & industrial use). Transportation charges on product submitted for repair or replacement under this warranty are the sole responsibility of the purchaser. This warranty applies only to the original purchaser and is not transferable.

### Do Not Return The Unit To The Place Of Purchase

Contact CPE's Technical Service and CPE will troubleshoot any issue via phone or e-mail. If the problem is not corrected by this method, CPE will, at its option, authorize evaluation, repair or replacement of the defective part or component at a CPE Service Center. CPE will provide you with a case number for warranty service. Please keep it for future reference. Repairs or replacements without prior authorization, or at an unauthorized repair facility, will not be covered by this warranty.

### Warranty Exclusions

This warranty does not cover the following repairs and equipment:

#### Normal Wear

Semi-trash pumps need periodic parts and service to perform well. This warranty does not cover repair when normal use has exhausted the life of a part or the equipment as a whole.

#### Installation, Use and Maintenance

This warranty will not apply to parts and/or labor if this semi-trash pump is deemed to have been misused, neglected, involved in an accident, abused, loaded beyond the semi-trash pump's limits, modified, installed improperly or connected incorrectly to any electrical component.

#### Installation, Use and Maintenance Cont'd.

Normal maintenance such as spark plugs, air filters, adjustments, fuel system cleaning and obstruction due to buildup is not covered by this warranty.

#### Other Exclusions

This warranty excludes:

- Cosmetic defects such as paint, decals, etc.
- Wear items such as filter elements, o-rings, etc.
- Accessory parts such as starting batteries, and storage covers.
- Failures to due acts of God and other force majeure events beyond the manufacturer's control.
- Problems caused by parts that are not original Champion Power Equipment parts.

This warranty does not apply to semi-trash pumps used for prime power in place of a utility.

#### Limits of Implied Warranty and Consequential Damage

Champion Power Equipment disclaims any obligation to cover any loss of time, use of this product, freight, or any incidental or consequential claim by anyone from using this semi-trash pump. THIS WARRANTY IS IN LIEU OF ALL OTHER WARRANTIES, EXPRESS OR IMPLIED, INCLUDING WARRANTIES OF MERCHANTABILITY OR FITNESS FOR A PARTICULAR PURPOSE.

A unit provided as an exchange will be subject to the warranty of the original unit. The length of the warranty governing the exchanged unit will remain calculated by reference to the purchase date of the original unit. This warranty gives you certain legal rights which may change from state to state. Your state may also have other rights you may be entitled to that are not listed within this warranty.

### Contact Information

#### Address

Champion Power Equipment, Inc.  
Customer Service  
12039 Smith Ave.  
Santa Fe Springs, CA 90670  
[www.championpowerequipment.com](http://www.championpowerequipment.com)

#### Customer Service

Mon – Fri 8:30 AM – 5:00 PM (PST/PDT)  
Toll Free: 1-877-338-0999  
[info@championpowerequipment.com](mailto:info@championpowerequipment.com)  
Fax no.: 1-562-236-9429

#### Technical Service

Mon – Fri 8:30 AM – 5:00 PM (PST/PDT)  
Toll Free: 1-877-338-0999  
[tech@championpowerequipment.com](mailto:tech@championpowerequipment.com)  
24/7 Tech Support: 1-562-204-1188

**Champion Power Equipment, Inc. (CPE),  
United States Environment Protection Agency (U.S. EPA)  
Emission Control System Warranty**

Your Champion Power Equipment (CPE) engine complies with U.S. EPA emission regulations.

**YOUR WARRANTY RIGHTS AND OBLIGATIONS:**

The US EPA AND CPE are pleased to explain the Federal Emission Control Systems Warranty on your 2015 small off-road engine and engine powered equipment. New engines and equipment must be designed, built and equipped, at the time of sale, to meet U.S. EPA regulations for small non-road engines. CPE warrants the emission control system on your small off-road engine and equipment for the period of time listed below, provided there has been no abuse, neglect, unapproved modification, or improper maintenance of your equipment.

Your emission control system may include parts such as the carburetor, fuel-injection system, the ignition system, catalytic converter and fuel lines. Also included may be hoses, belts, connectors and other emission related assemblies. Where a warrantable condition exists, CPE will repair your small off-road engine at no cost to you including diagnosis, parts and labor.

**MANUFACTURER'S EMISSION CONTROL SYSTEM WARRANTY COVERAGE:**

This emission control system is warranted for two years, subject to provisions set forth below. If, during the warranty period, emission related part on your engine is defective in materials or workmanship, the part will be repaired or replaced by CPE.

**OWNER WARRANTY RESPONSIBILITIES:**

As the small off-road engine owner, you are responsible for the performance of the required maintenance listed in your Owner's Manual. CPE recommends that you retain all your receipts covering maintenance on your small off-road engine, but CPE cannot deny warranty solely for the lack of receipts or for your failure to ensure the performance of all scheduled maintenance.

As the small off-road engine owner, you should however be aware that CPE may deny you warranty coverage if your small, off-road engine or a part has failed due to abuse, neglect, improper maintenance or unapproved modifications.

You are responsible for presenting your small off-road engine to an Authorized CPE service outlet or alternate service outlet as described in (3)(f.) below, CPE dealer or CPE, Santa Fe Springs, Ca. as soon as a problem exists. The warranty repairs should be completed in a reasonable amount of time, not to exceed 30 days.

If you have any questions regarding your warranty rights and responsibilities, you should contact:

Champion Power Equipment, Inc.  
Customer Service  
12039 Smith Ave.  
Santa Fe Springs, CA 90670  
1-877-338-0999  
tech@championpowerequipment.com

## **EMISSION CONTROL SYSTEM WARRANTY**

**The following are specific provisions relative to your Emission Control System (ECS) Warranty Coverage.**

**1. APPLICABILITY:** This warranty shall apply to 1997 and later model year small off-road engines. The ECS Warranty Period shall begin on the date the new engine or equipment is delivered to its original, end-use purchaser, and shall continue for 24 consecutive months thereafter.

### **2. GENERAL EMISSIONS WARRANTY COVERAGE**

CPE warrants to the original, end-use purchaser of the new engine or equipment and to each subsequent purchaser that each of its small off-road engines is:

- a. Designed, built and equipped so as to conform to U.S. EPA emissions standards for spark-ignited engines at or below 19 kilowatts.
- b. Free from defects in materials and workmanship that cause the failure of a warranted part to be identical in all material respects to the part as described in the engine manufacturer's application for certification for a period of two years.

### **3. THE WARRANTY ON EMISSION-RELATED PARTS WILL BE INTERPRETED AS FOLLOWS:**

a. Any warranted part that is not scheduled for replacement as required maintenance in the Owners Manual shall be warranted for the ECS Warranty Period. If any such part fails during the ECS Warranty Period, it shall be repaired or replaced by CPE according to Subsection "d" below. Any such part repaired or replaced under the ECS Warranty shall be warranted for any remainder of the ECS Warranty Period.

b. Any warranted, emissions-related part which is scheduled only for regular inspection as specified in the Owners Manual shall be warranted for the ECS Warranty Period. A statement in such written instructions to the effect of "repair or replace as necessary", shall not reduce the ECS Warranty Period. Any such part repaired or replaced under the ECS Warranty shall be warranted for the remainder of the ECS Warranty Period.

c. Any warranted, emissions-related part which is scheduled for replacement as required maintenance in the Owner's Manual shall be warranted for the period of time prior to the first scheduled replacement point for that part. If the part fails prior to the first scheduled replacement, the part shall be repaired or replaced by CPE according to Subsection "d" below. Any such emissions-related part repaired or replaced under the ECS Warranty, shall be warranted for the remainder of the ECS Warranty Period prior to the first scheduled replacement point for such emissions-related part.

d. Repair or replacement of any warranted, emissions-related part under this ECS Warranty shall be performed at no charge to the owner at a CPE Authorized Service Outlet.

e. The owner shall not be charged for diagnostic labor which leads to the determination that a part covered by the ECS Warranty is in fact defective, provided that such diagnostic work is performed at a CPE Authorized Service Outlet.

f. CPE shall pay for covered emissions warranty repairs at non-authorized service outlets under the following circumstances:

i. The service is required in a population center with a population over 100,000 according to U.S. Census 2000 without a CPE Authorized Service Outlet AND

ii. The service is required more than 100 miles from a CPE Authorized Service Outlet. The 100 mile limitation does not apply in the following states: Alaska, Arizona, Colorado, Hawaii, Idaho, Montana, Nebraska, Nevada, New Mexico, Oregon, Texas, Utah and Wyoming.

g. CPE shall be liable for damages to other original engine components or approved modifications proximately caused by a failure under warranty of an emission-related part covered by the ECS Warranty.

h. Throughout the ECS Warranty Period, CPE shall maintain a supply of warranted emission-related parts sufficient to meet the expected demand for such emission-related parts.

i. Any CPE Authorized and approved emission-related replacement part may be used in the performance of any ECS Warranty maintenance or repair and will be provided without charge to the owner. Such use shall not reduce CPE's warranty obligation.

j. Unapproved add-on or modified parts may not be used to modify or repair a CPE engine. Such use voids this ECS Warranty and shall be sufficient grounds for disallowing an ECS Warranty claim. CPE shall not be liable hereunder for failures of any warranted parts of a CPE engine caused by the use of such an unapproved add-on or modified part.

**EMISSION-RELATED PARTS INCLUDE THE FOLLOWING: (using those portions of the list applicable to the engine)**

Systems covered by this warranty	Parts Description
Fuel Metering System	Fuel regulator, Carburetor and internal parts
Air Induction System	Air cleaner, Intake manifold
Ignition System	Spark plug and parts, Magneto ignition system
Exhaust System	Exhaust manifold, catalytic converter
Miscellaneous Parts	Tubing, Fittings, Seals, Gaskets, and Clamps associated with these listed systems.
Evaporative Emissions	Fuel Tank, Fuel Cap, Fuel Line, Fuel Line Fittings, Clamps, Pressure Relief Valves, Control Valves, Control Solenoids, Electronic Controls, Vacuum Control Diaphragms, Control Cables, Control Linkages, Purge Valves, Vapor Hoses, Liquid/Vapor Separator, Carbon Canister, Canister Mounting Brackets, Carburetor Purge Port Connector

**TO OBTAIN WARRANTY SERVICE:**

You must take your CPE engine or the product on which it is installed, along with your warranty registration card or other proof of original purchase date, at your expense, to any Champion Power Equipment dealer who is authorized by Champion Power Equipment, Inc. to sell and service that CPE product during his normal business hours. Alternate service locations defined in Section (3)(f.) above must be approved by CPE prior to service. Claims for repair or adjustment found to be caused solely by defects in material or workmanship will not be denied because the engine was not properly maintained and used.

**If you have any questions regarding your warranty rights and responsibilities, or to obtain warranty service, please write or call Customer Service at Champion Power Equipment, Inc.**

**Champion Power Equipment, Inc.  
12039 Smith Ave.  
Santa Fe Springs, CA 90670  
1-877-338-0999  
Attn.: Customer Service  
tech@championpowerequipment.com**