

# Storage Cabinet / Armoire De Rangement

N717P381214 / N717P381227

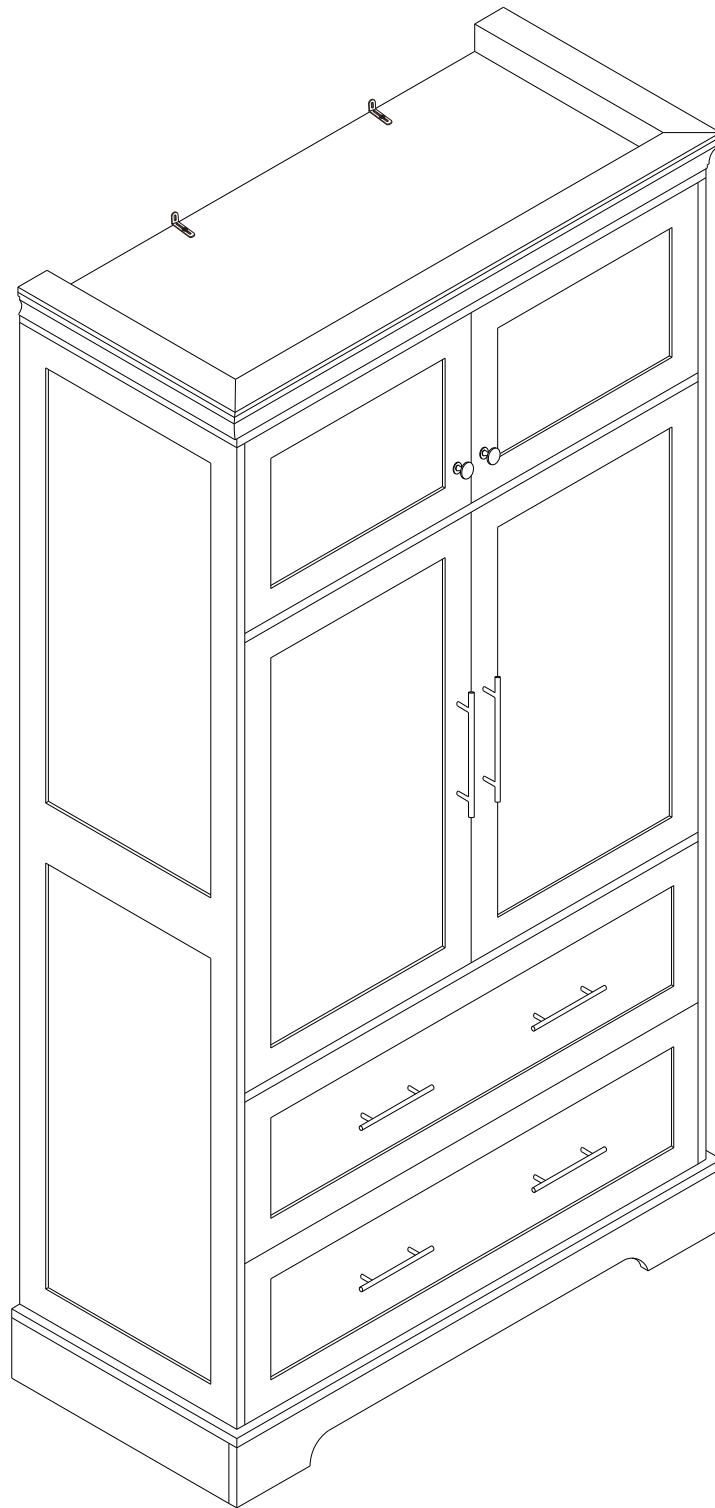

 <b>WARNING</b>	
	<p>This product is NOT a Clothing Storage Unit (CSU). DO NOT use it for clothing storage. Improper use may cause furniture tipover.</p>



## Safety and Care/Conseils de sécurité et d'entretien

**\*Important - Please read these instructions fully before starting assembly/ Important - Veuillez lire attentivement ces instructions avant de commencer l'assemblage**

+ Check you have all the components and tools listed on the following pages  
/Vérifiez que vous disposez de tous les composants et outils répertoriés dans les pages suivantes.

+ Remove all fittings from the plastic bags and separate them into their groups.  
/Retirez tous les accessoires du plastique sacs et séparés les répartir dans leurs groupes.

+Keep children and animals away from the work area, small parts could choke if swallowed.  
/Tenir les enfants et les animaux éloignés depuis le travail zone, petites pièces pourrait étouffer si avalé.

+ Make sure you have enough space to layout the parts before starting.  
/Assurez-vous d'avoir suffisamment d'espace à mise en page les parties avant de commencer.

+During assembly do not stand or put weight on the product, this could cause damage  
/Pendant assemblée faire pas Ne vous tenez pas debout ou ne mettez pas de poids sur le produit, cela pourrait l'endommager.

+Assemble the item as close to its final position (in the same room) as possible.  
/Assemblez l'article aussi près que possible c'est final position (dans le (même pièce) que possible.

+Assemble on a soft level surface to avoid damaging the unit or your floor.  
/Assembler sur une surface plane et douce à éviter dommageable l'unité ou votre étage.

+Parts of the assembly will be easier with 2 people./Parties de le assemblée volonté ce sera plus facile avec 2 personnes



+To reduce the likelihood of damaging your product please ensure that your power drill is set on a low torque setting.  
/Pour réduire la probabilité d'endommager votre produit s'il vous plaît assurez-vous que votre alimentation perceur est ensemble sur un faible réglage du couple .

### \*Care and maintenance/Soins et entretien

+Only clean using a damp cloth and mild detergent, do not use bleach or abrasive cleaners.  
/Seulement faire le ménage en utilisant un humide chiffon et détergent doux, n'utilisez pas d'eau de Javel ni de nettoyants abrasifs

+From time to time check that there are no loose screws on this unit.  
/Depuis temps à temps vérifier qu'il n'y a pas de vis desserrées sur cette unité.

+This product should not be discarded with household waste. Take to your local authority waste disposal centre  
/Ce produit ne doit pas être jeté avec ménage Déchets. Apportez-les à la déchetterie de votre commune.

### \*Handy Hints/Pratique Conseils

+Assemble all parts and bolts loosely during assembly, only once the product is complete should you fully tighten the bolts  
/Assemblez toutes les pièces et les boulons sans les serrer pendant l'assemblage. Une fois le produit terminé, toi pleinement serrer le boulons

+Regularly check and ensure That all bolts and fittings are tightend properly.  
/Régulièrement vérifier et Assurez-vous que tous les boulons et raccords sont correctement serrés.

### WARNING/AVERTISSEMENT

In order to help prevent overturning, please follow these instructions  
/Afin d'éviter tout renversement, veuillez suivre ces instructions

To help prevent product toppling over please follow the below steps  
/À aide prévenir produit renverser sur s'il te plaît suivre le ci-dessous mesures:

Use the anti tip stap or wall fixing method provided (if applicable)  
/Utilisez la méthode anti-basculément ou de montage mural fournie (le cas échéant)  
Do not allow children to climb or hang on the furniture  
/Ne laissez pas les enfants grimper ou s'accrocher aux meubles  
Do not open more than one drawer at a time  
/ N'ouvrez pas plus d'un tiroir à la fois  
Do not place heavy items in the top drawers  
/Ne placez pas d'objets lourds dans les tiroirs supérieurs  
Do not place heavy items on top of the furniture, unless the furniture has been designed for this purpose  
/Ne placez pas d'objets lourds sur le meuble, sauf si celui-ci a été conçu à cet effet.

# ASSEMBLY INSTRUCTIONS

## INSTRUCTIONS DE MONTAGE

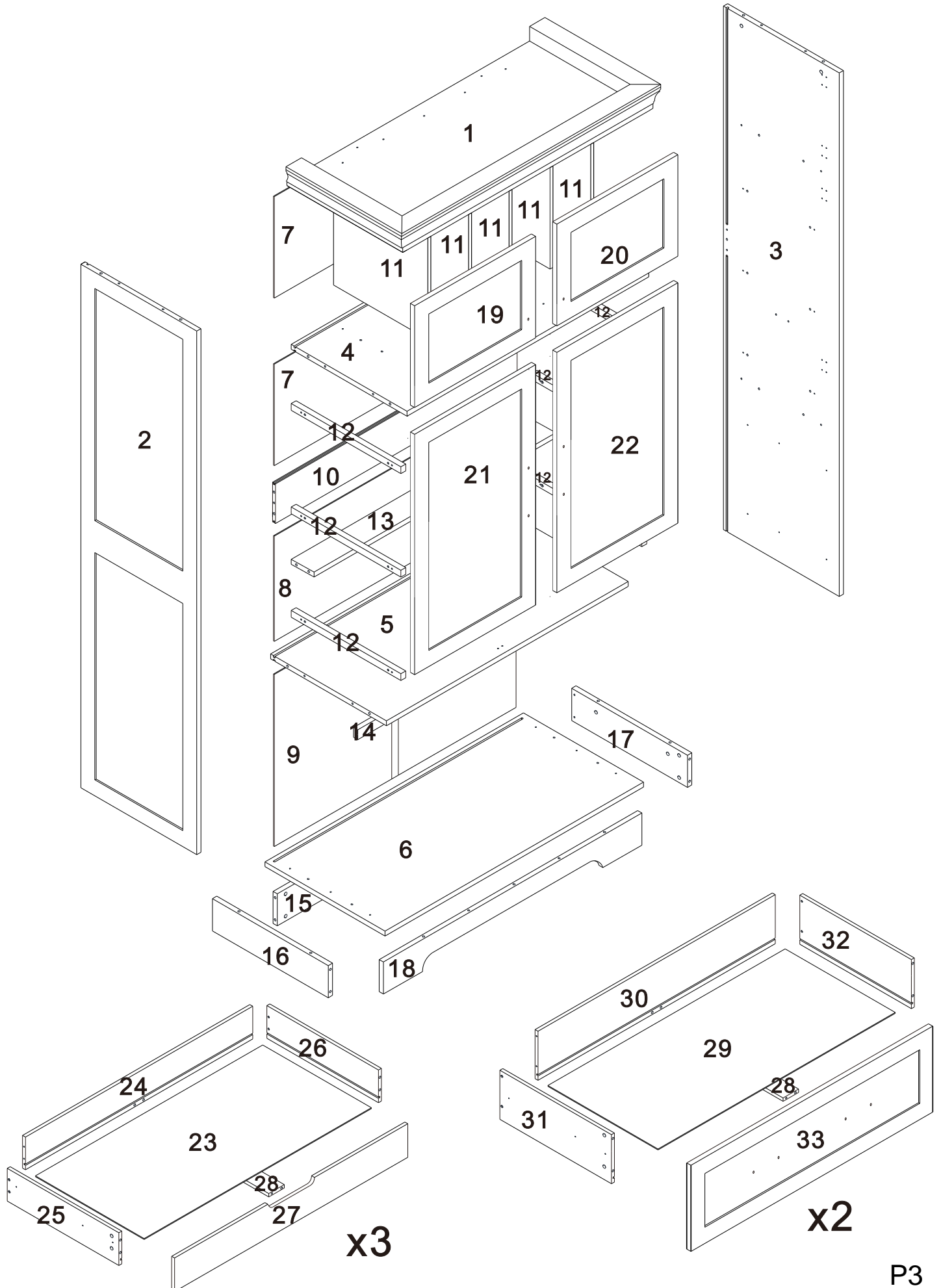

# ASSEMBLY INSTRUCTIONS

## INSTRUCTIONS DE MONTAGE



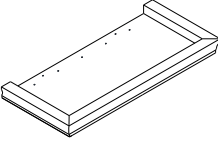
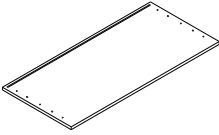
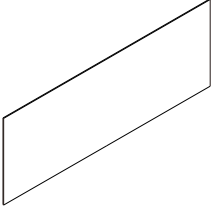
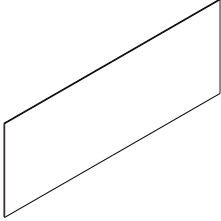
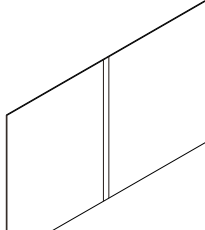
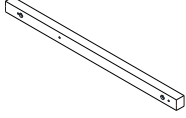
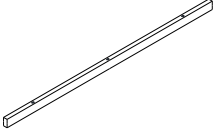
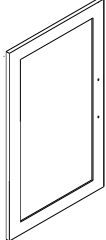
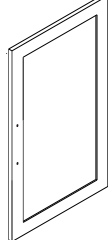
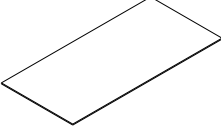
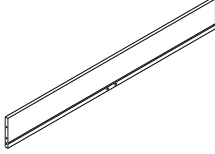
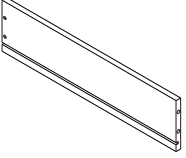
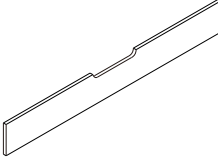
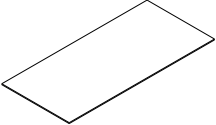
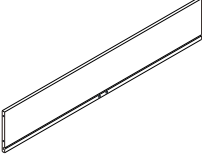
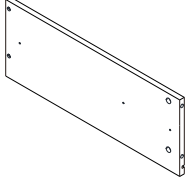
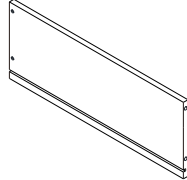
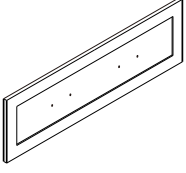

N717P381214 CARTON CONTENT/CONTENU DU CARTON

					
1 x 1pc	6 x 1pc	7x 2 pcs	8 x 1pc	9 x 1pc	12 x 6 pcs
					
14 x 1pc	21x 1pc	22x 1pc	23 x 3 pcs	24 x 3 pcs	26 x 2 pcs
					
27 x 3 pcs	29 x 2 pcs	30 x 2 pcs	31 x 2 pcs	32 x 2 pcs	33 x 2 pcs

# ASSEMBLY INSTRUCTIONS



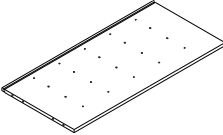
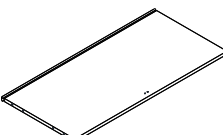
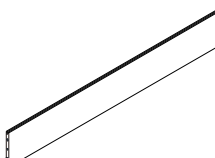
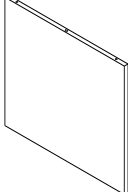
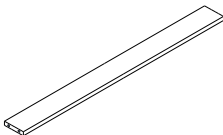
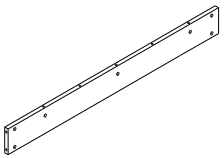
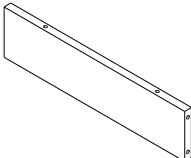
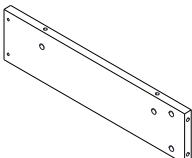
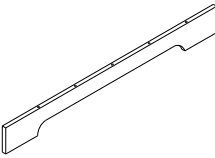
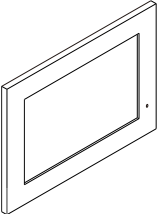
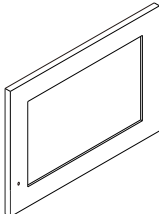
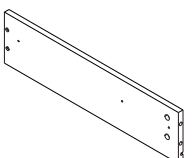
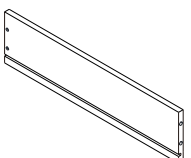
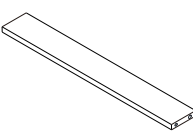









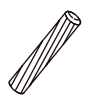



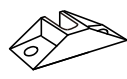

## INSTRUCTIONS DE MONTAGE

N717P381227 CARTON CONTENT/CONTENU DU CARTON

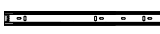
					
2 x 1pc	3 x 1pc	4 x 1pc	5 x 1pc	10 x 1pc	11 x 5 pcs
					
13 x 1pc	15 x 1pc	16 x 1pc	17 x 1pc	18 x 1pc	19 x 1pc
					
20 x 1pc	25 x 3 pcs	26 x 1 pcs	28 x 5 pcs	HARDWARE BOX le matériel	

# ASSEMBLY INSTRUCTIONS

## INSTRUCTIONS DE MONTAGE

A x 63 	B x 63 	C x 61 	E x 66  Ø3x12mm	F x 65  Ø4x35mm	G x 6  Ø5x40mm	I x 4  Ø4x25mm	J x 48  Ø4x14mm
K x 24  Ø3x16mm	L x 3 	M x 24 	N x 8 	O x 2 	P x 10 	Q x 4 	R x 2 
S x 2 	T x 8  Ø4x14 mm	U x 2  Ø4x20mm					

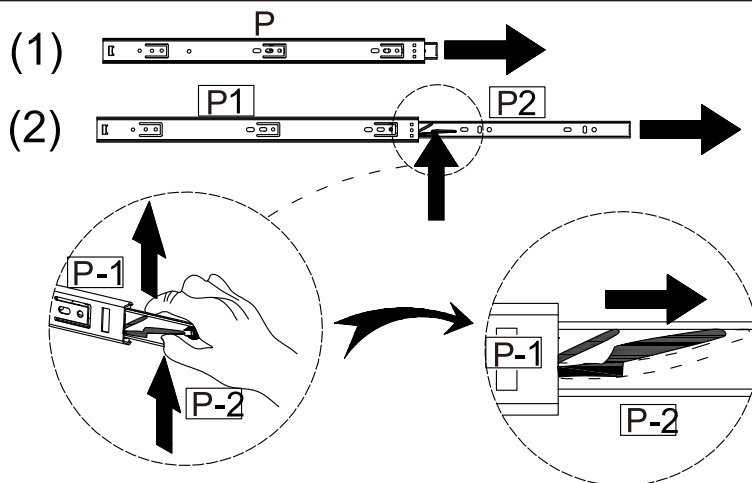

Move the black paddle upward and pull out (P2) to the right.

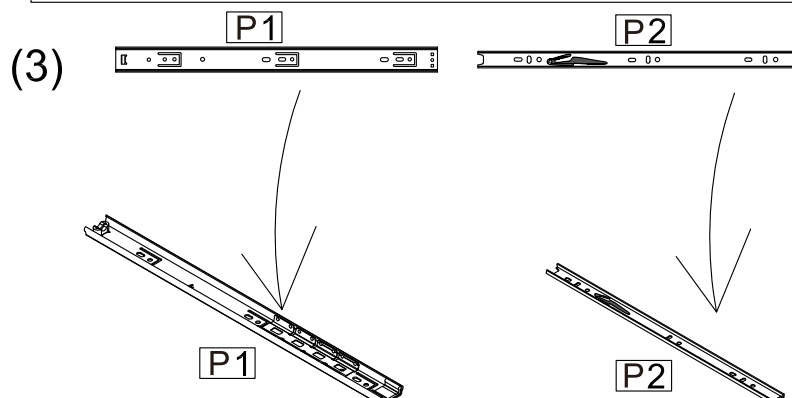

Step 1  
Étape

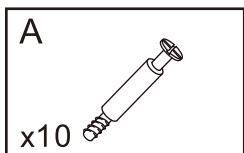
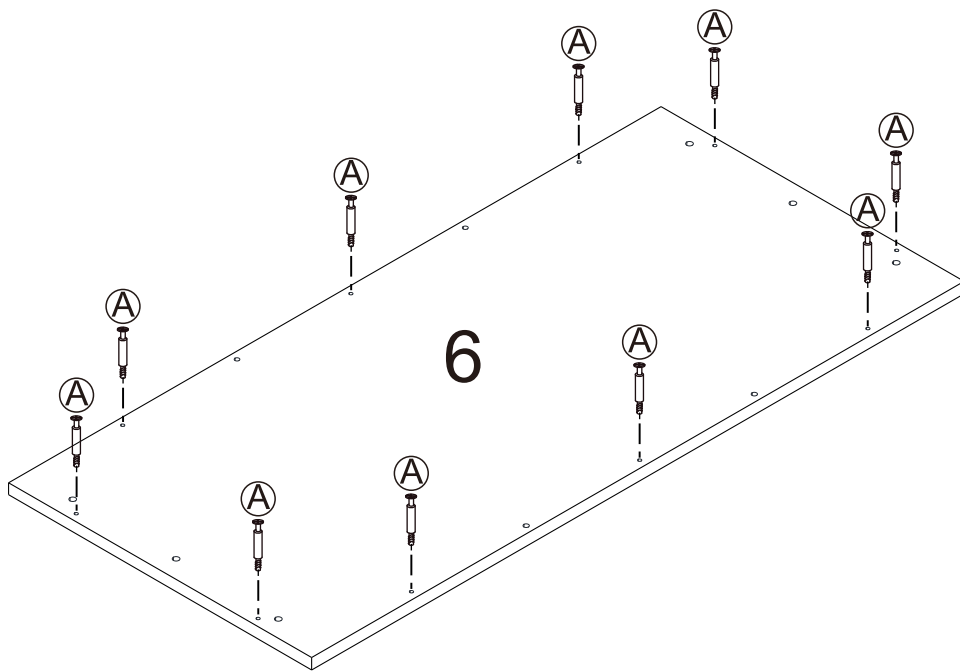

Step 2  
Étape

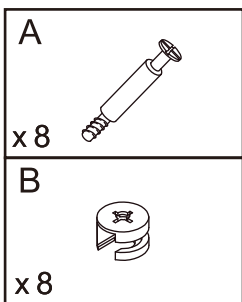
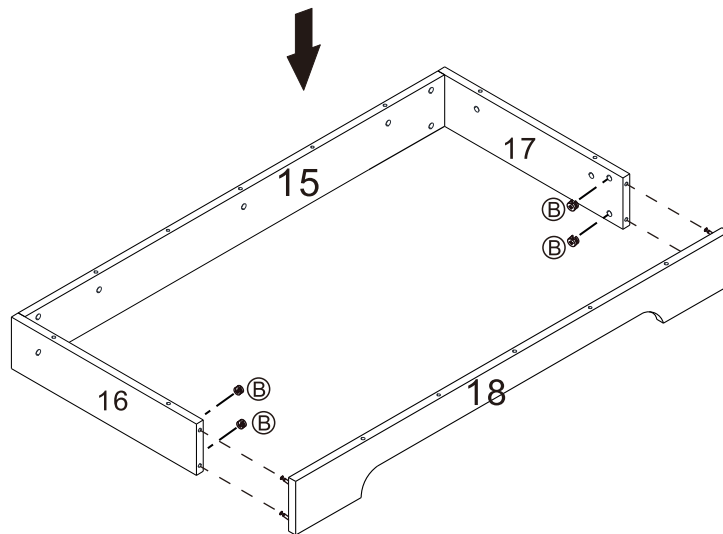
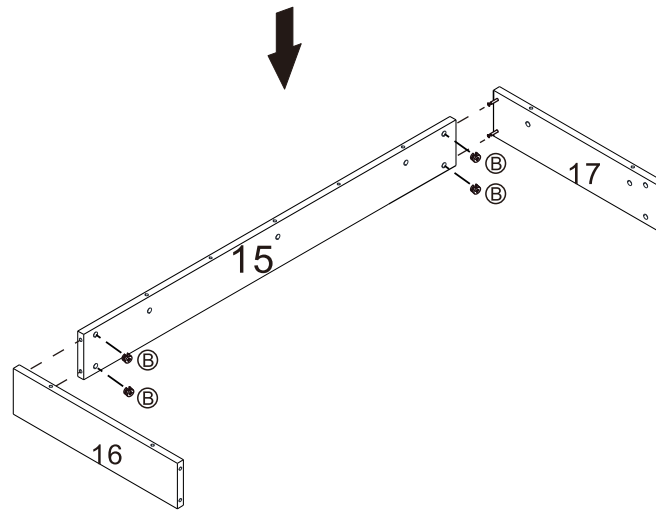
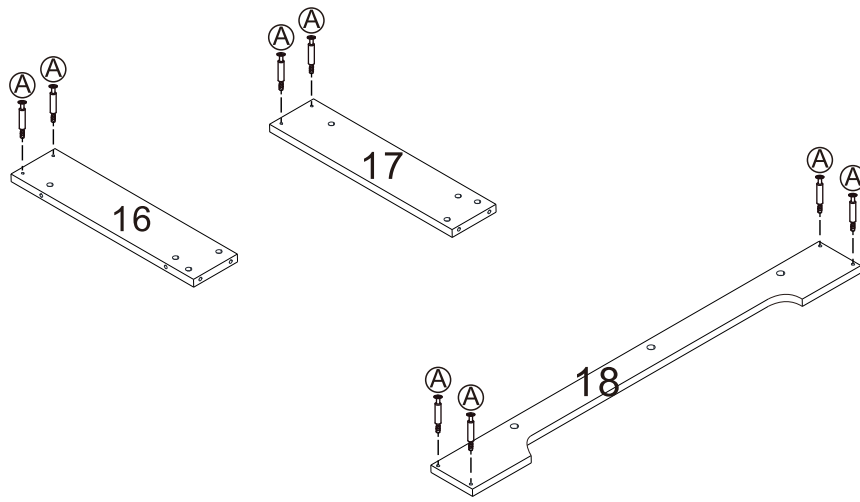

Step 3  
Étape

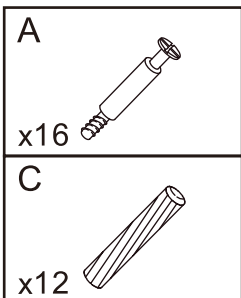
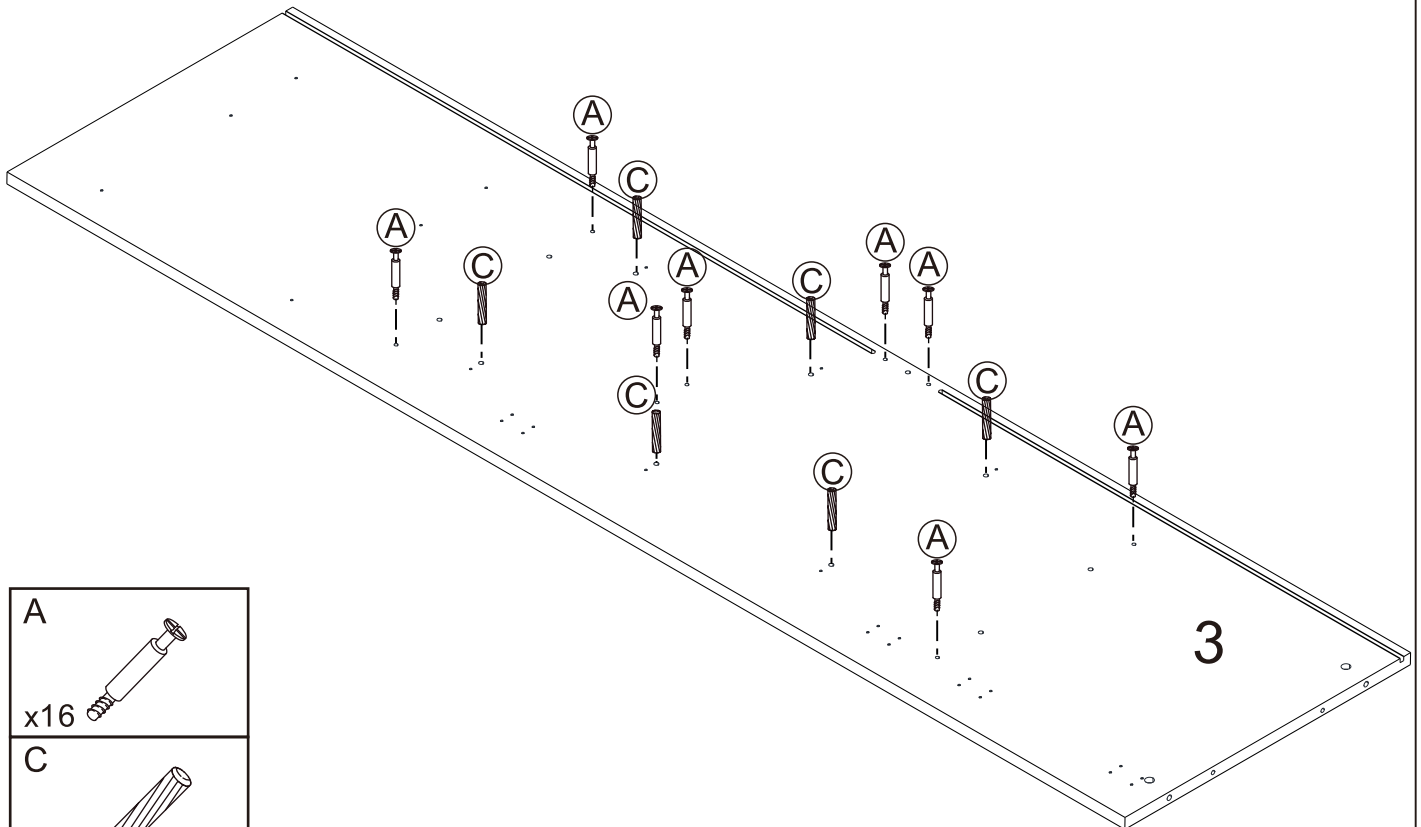
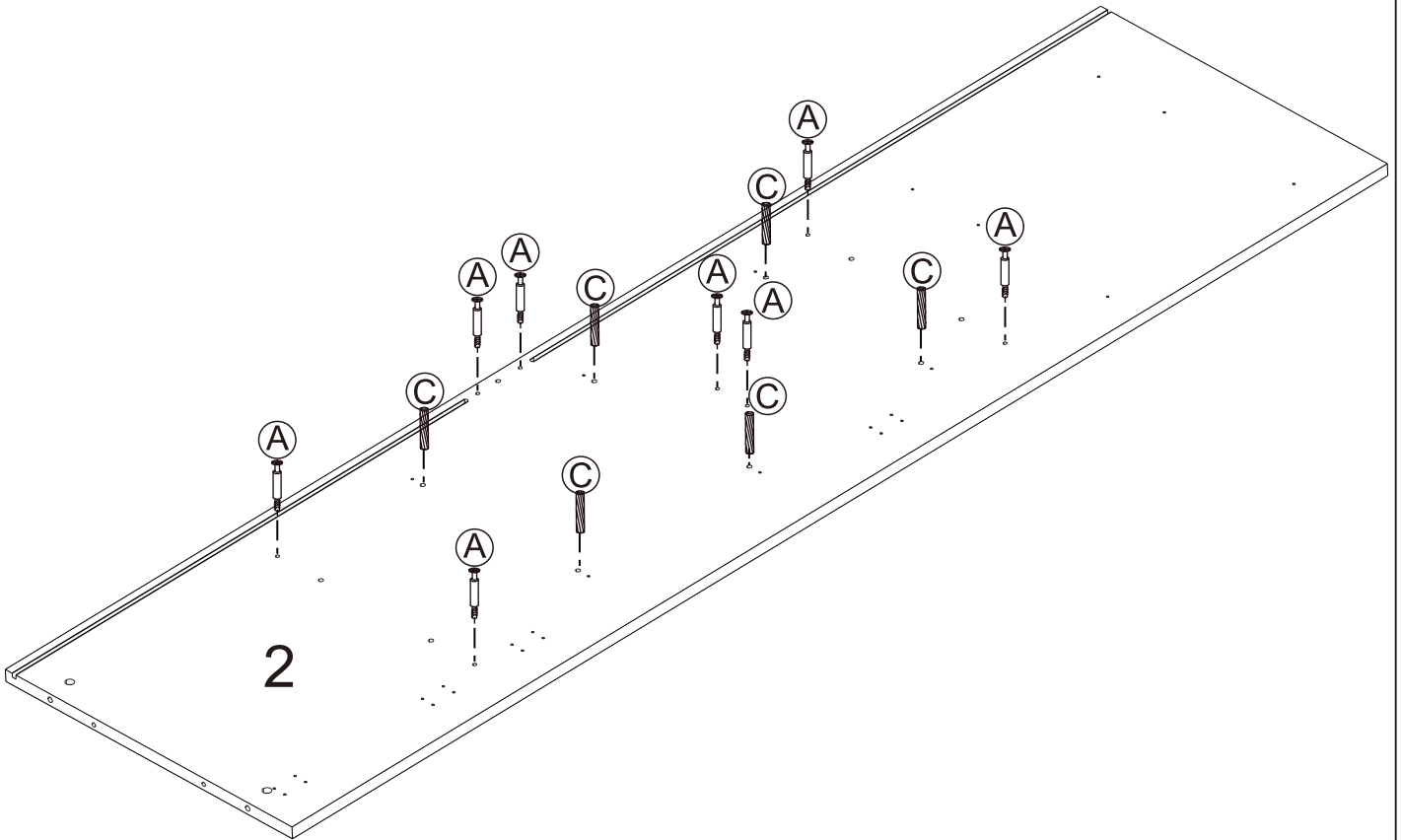

Step 4  
Étape

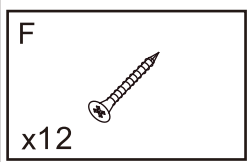
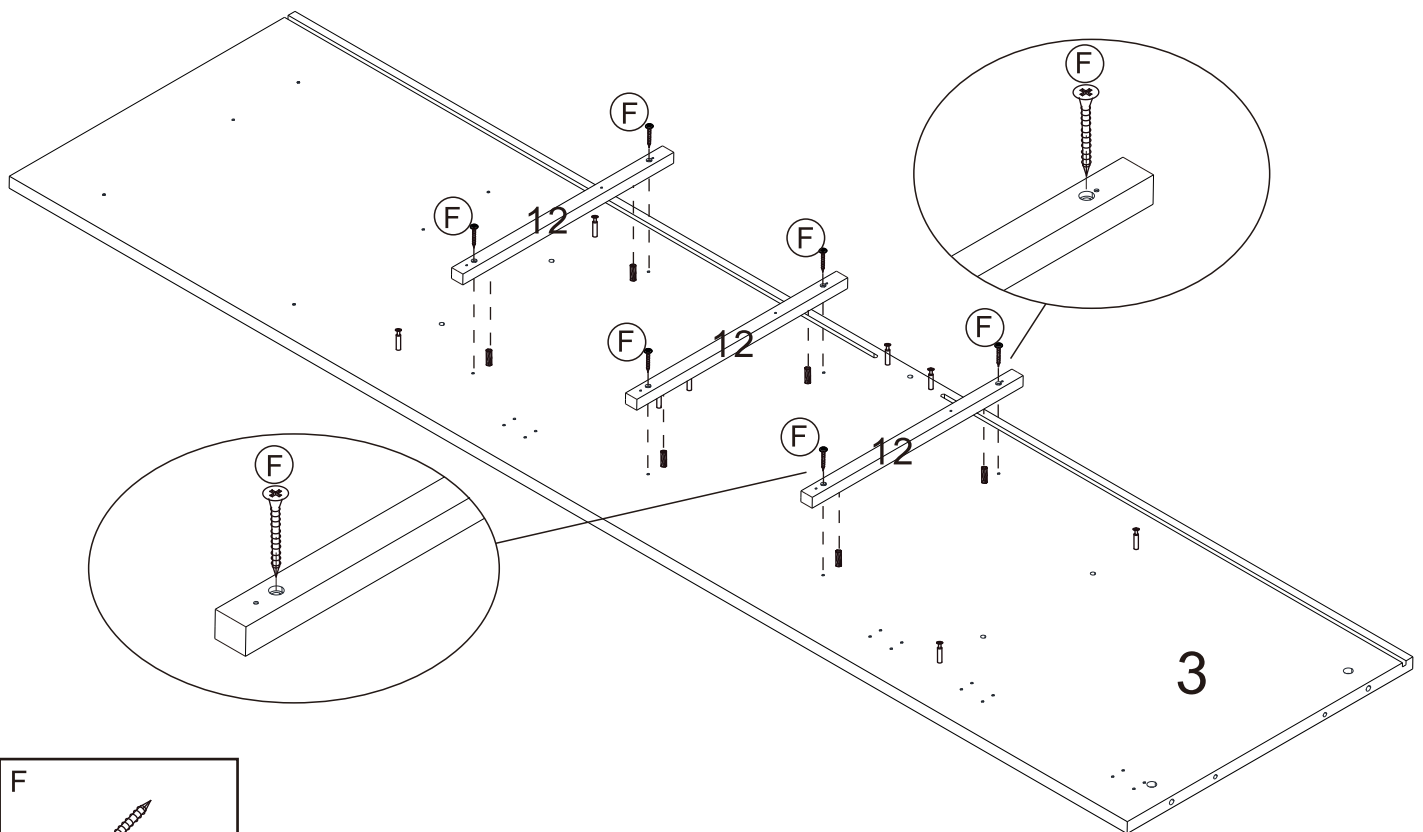
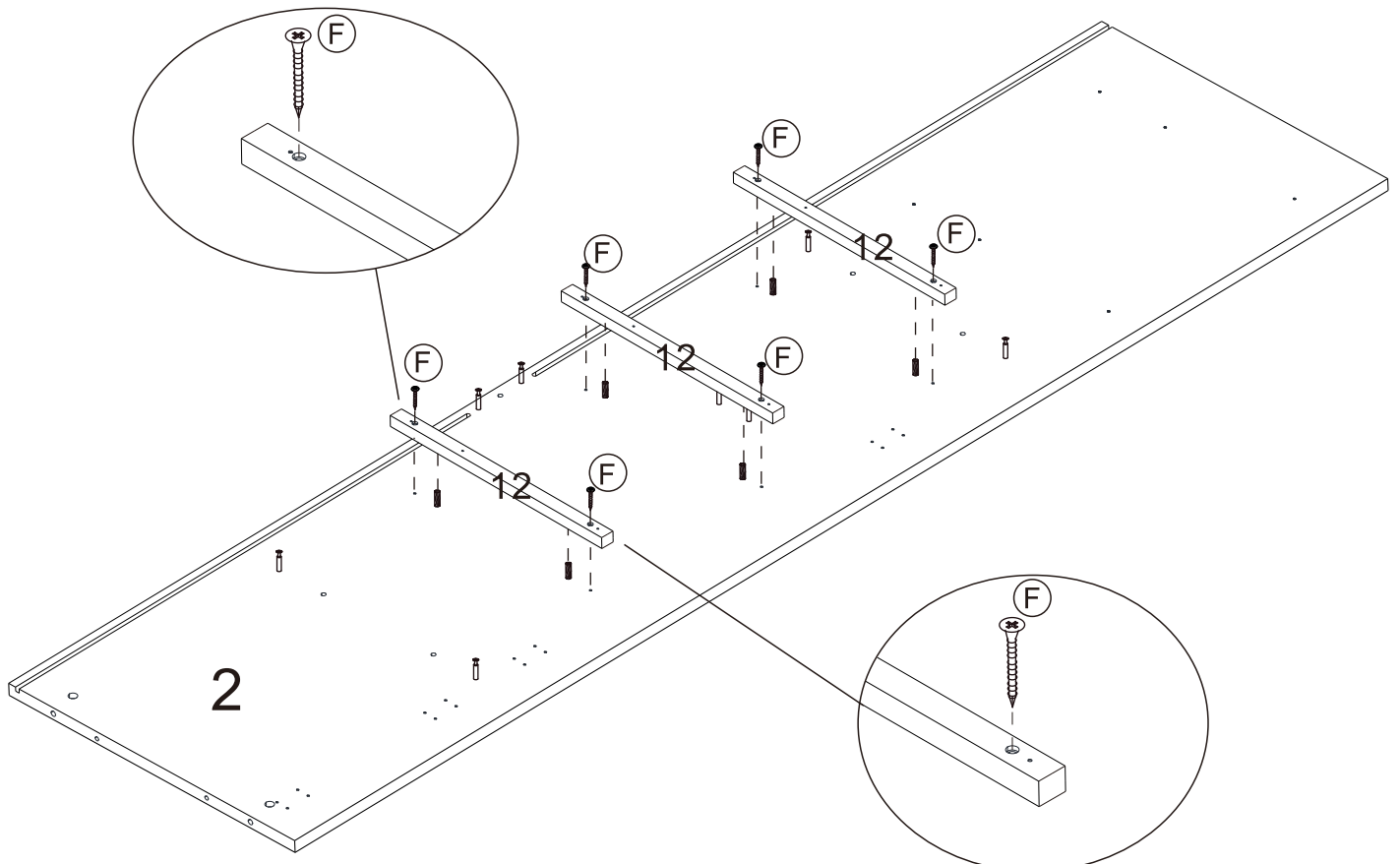

Step 5  
Étape

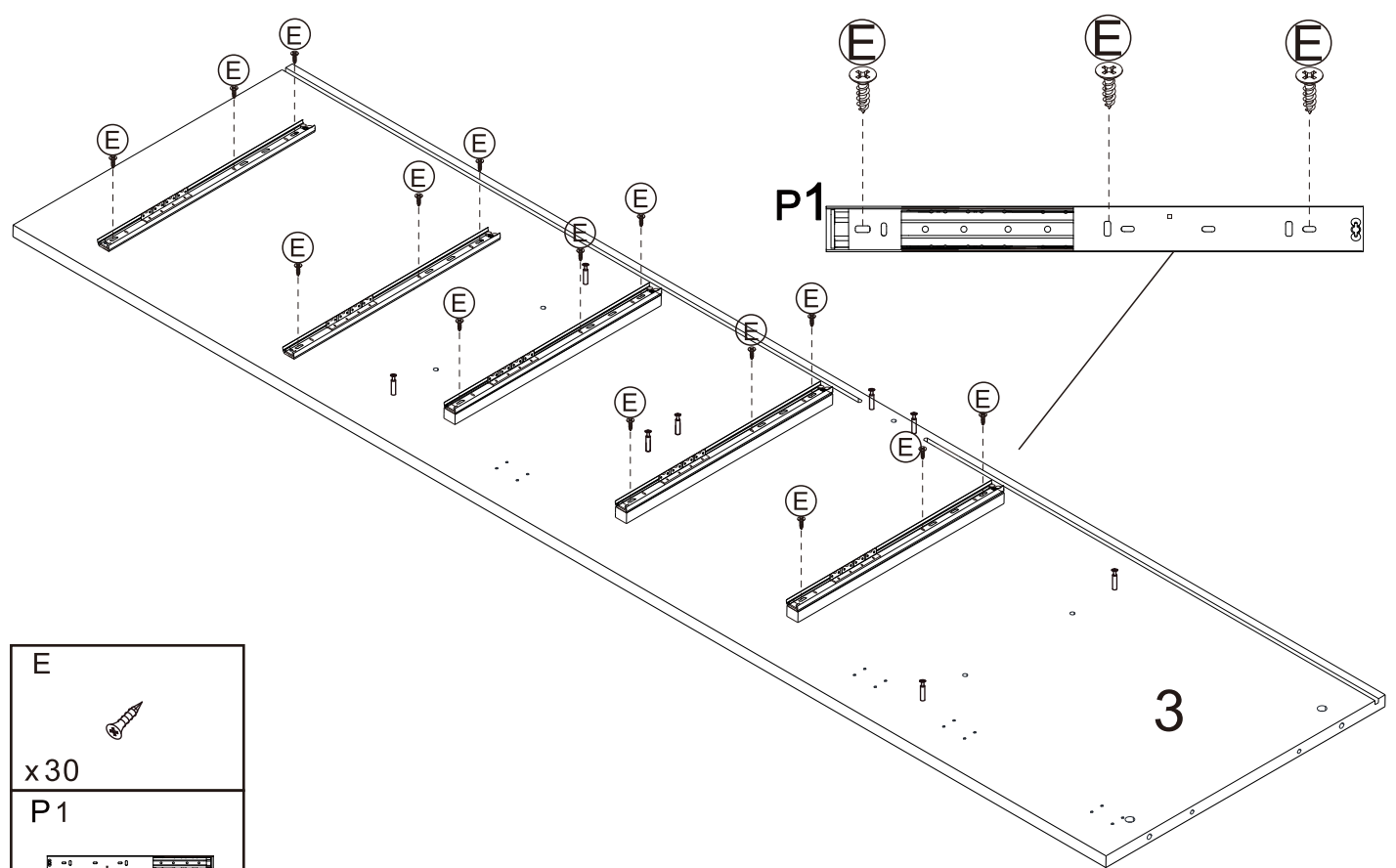
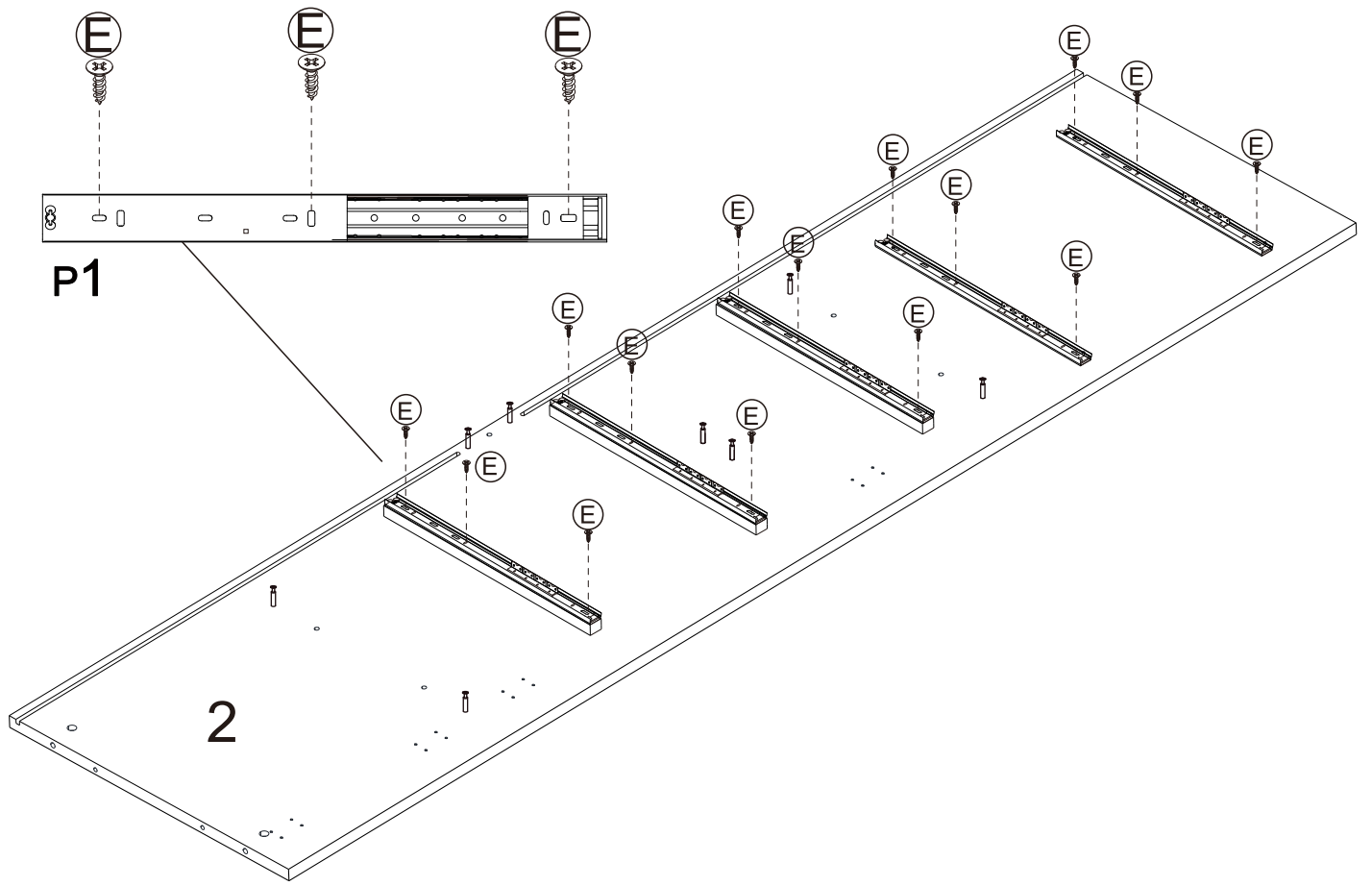

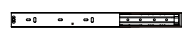
E

x 30
P1

x 10

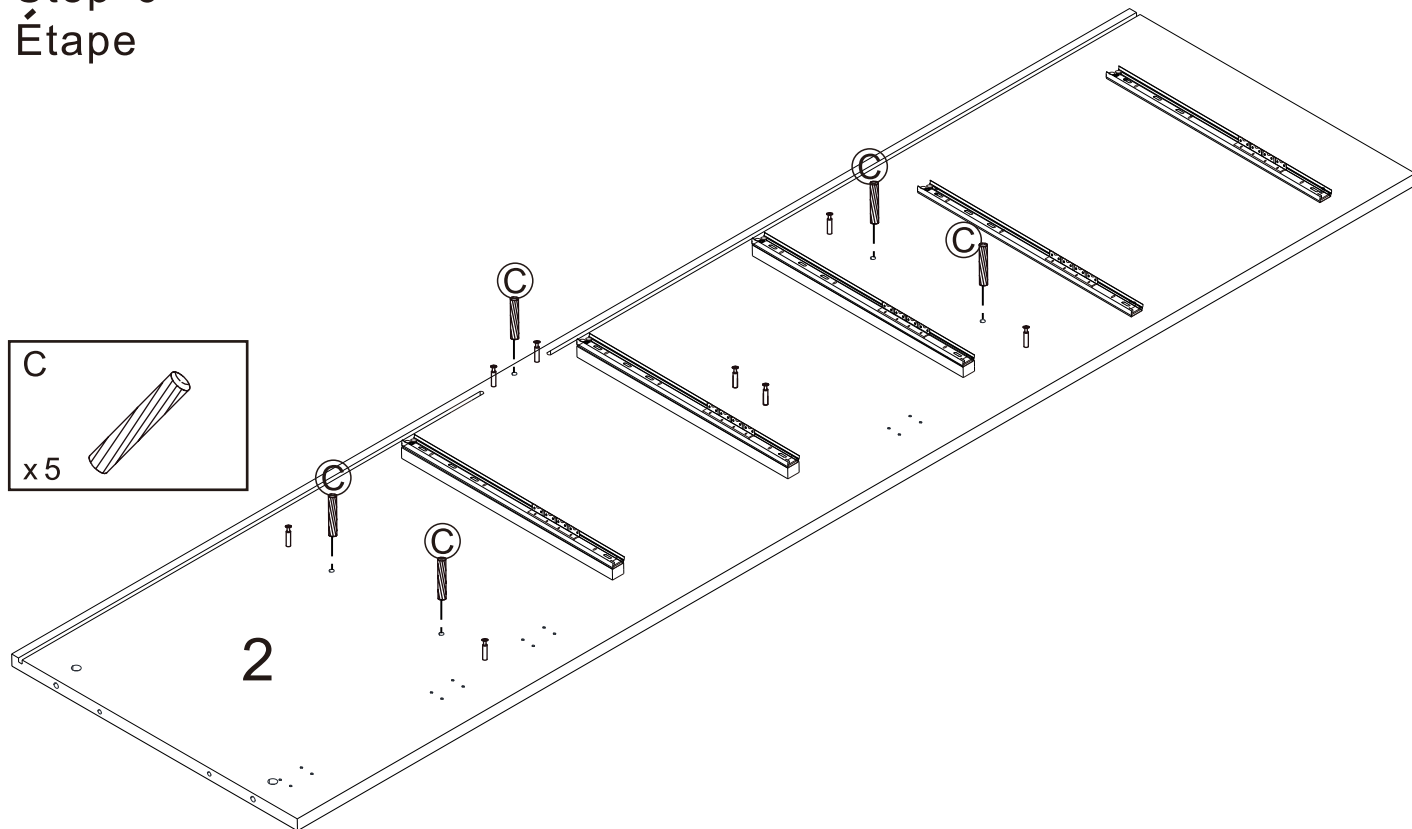
P11

Step 6  
Étape

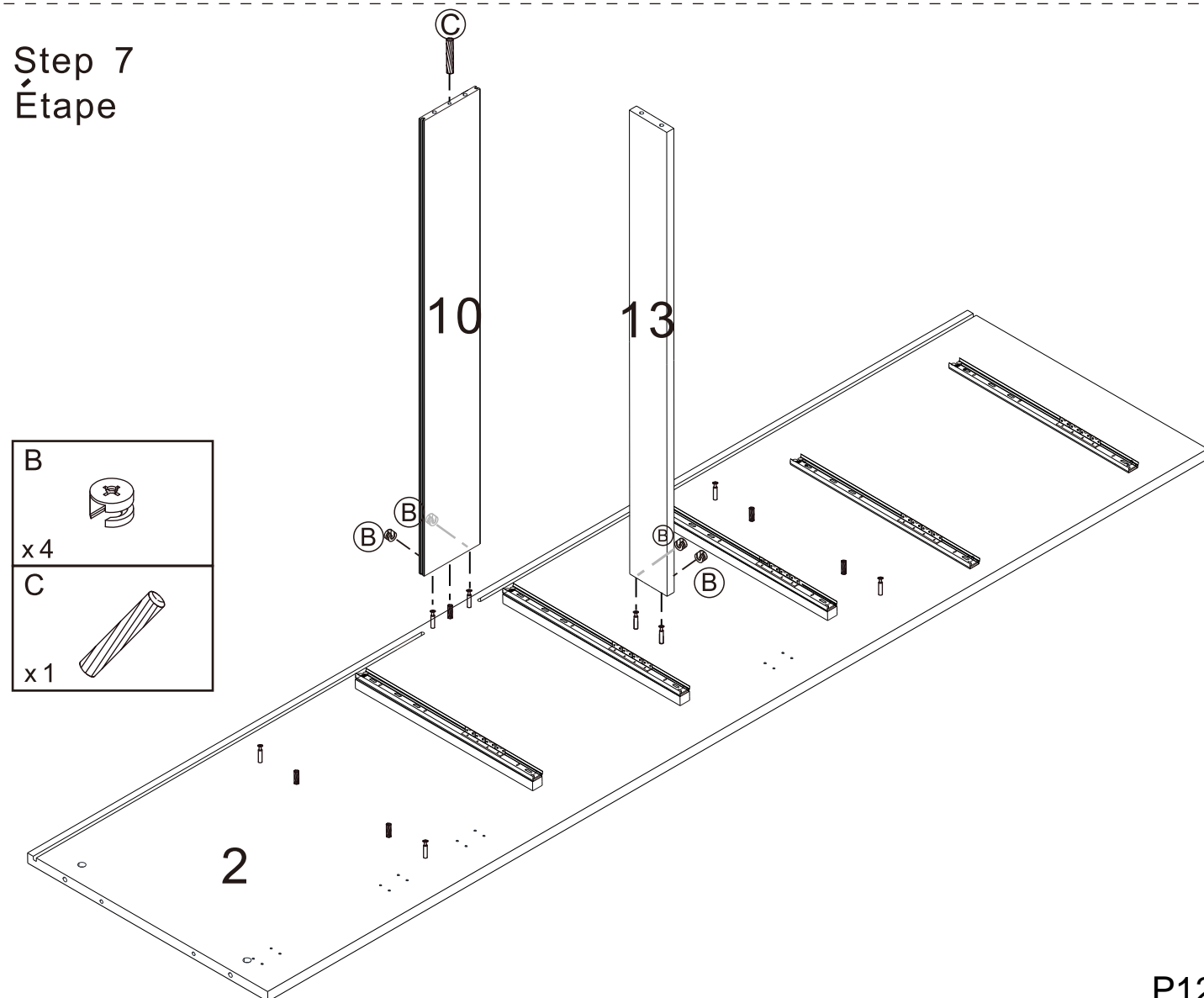

Step 7  
Étape



Step 8  
Étape

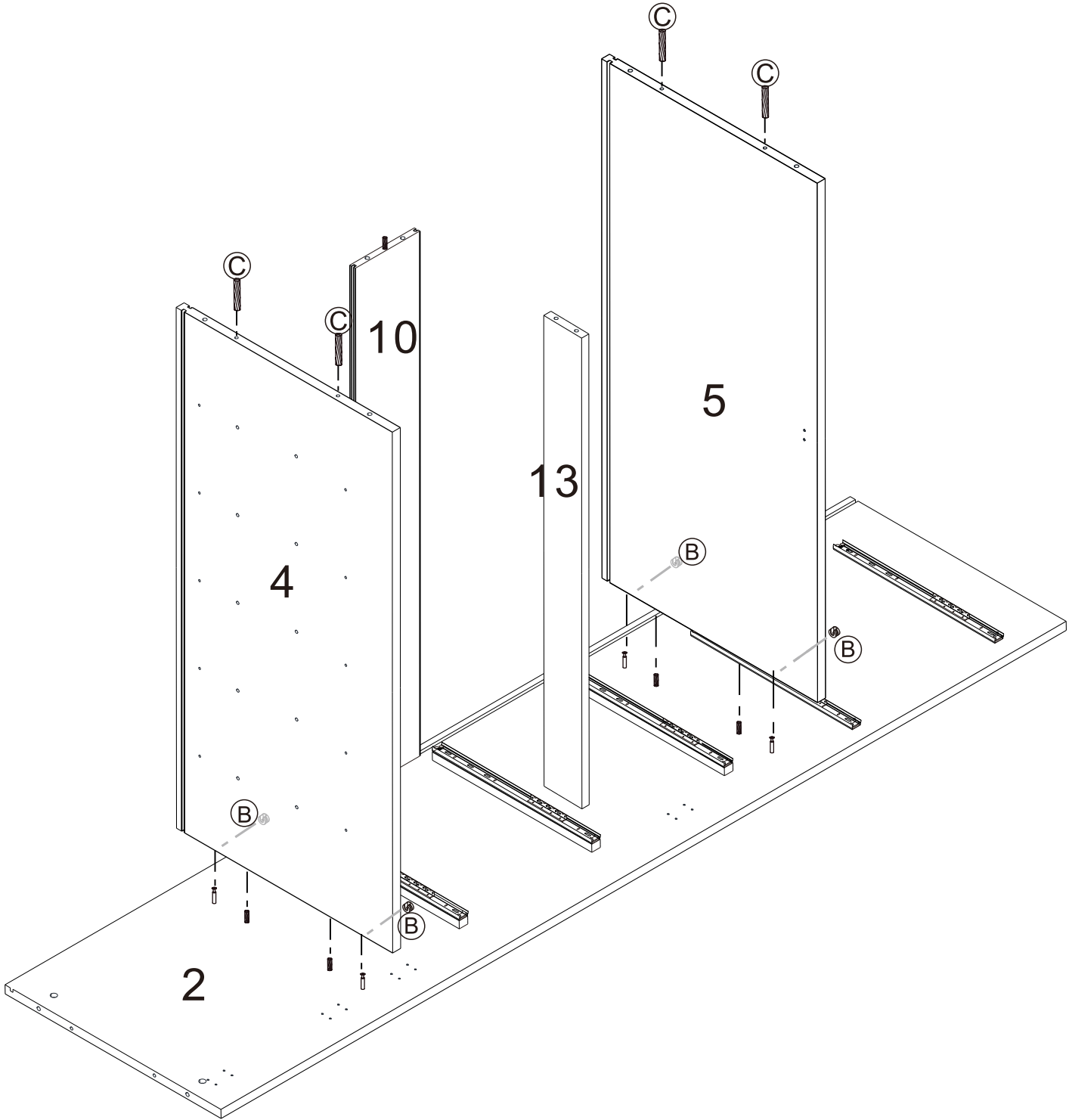

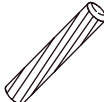
B	
x4	
C	
x4	

Step 9  
Étape

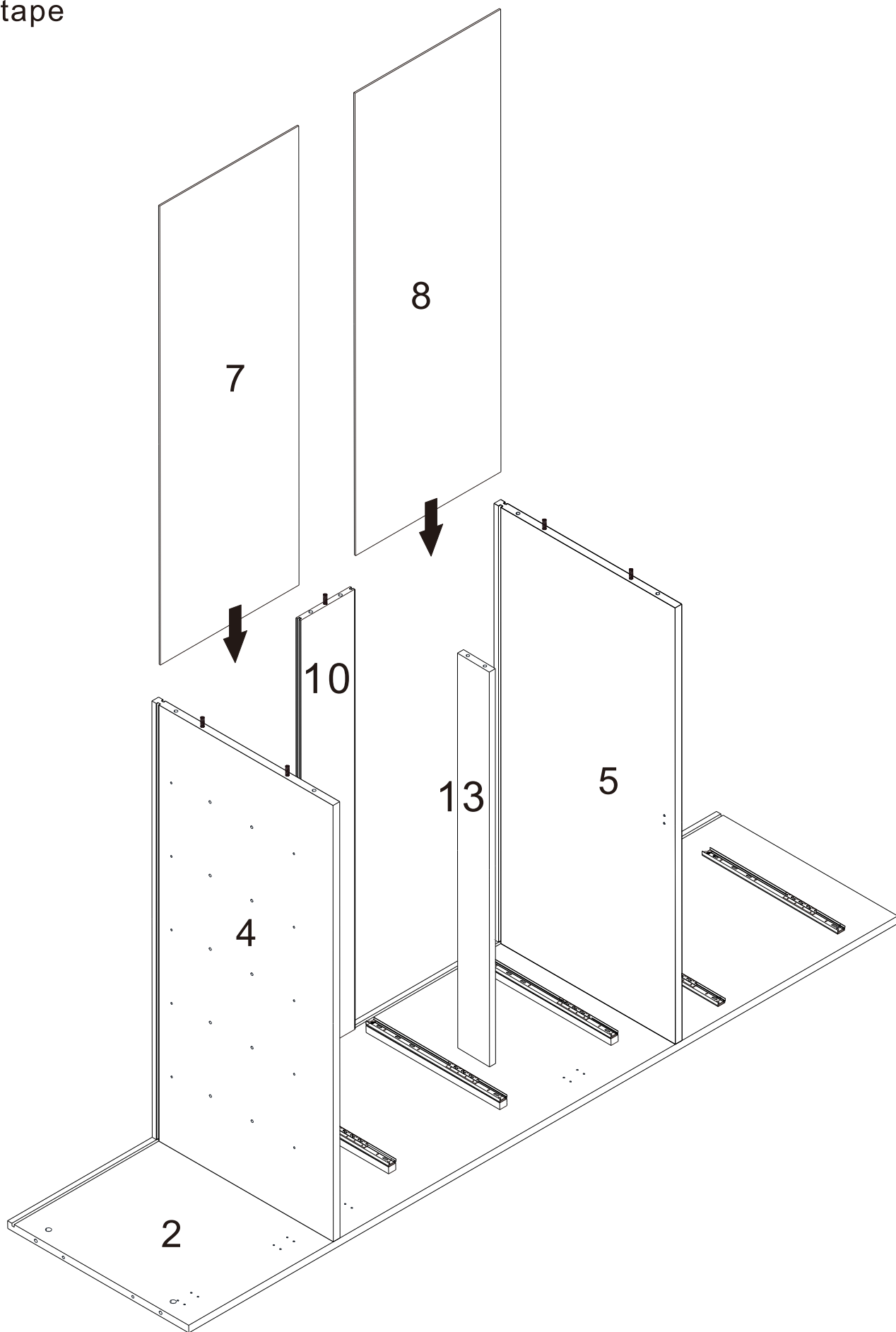

Step 10  
Étape

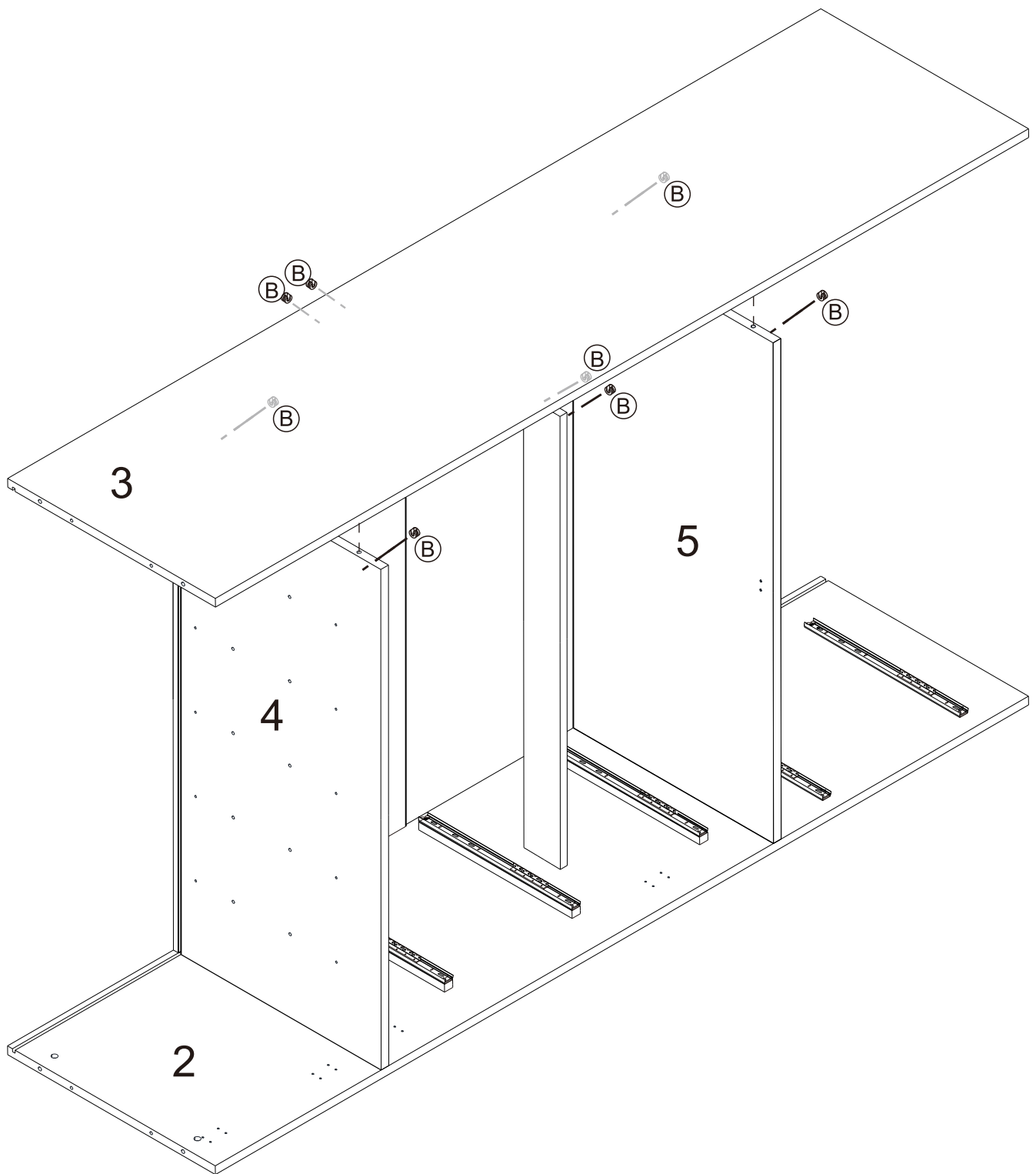

Step 11  
Étape

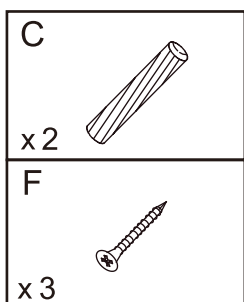
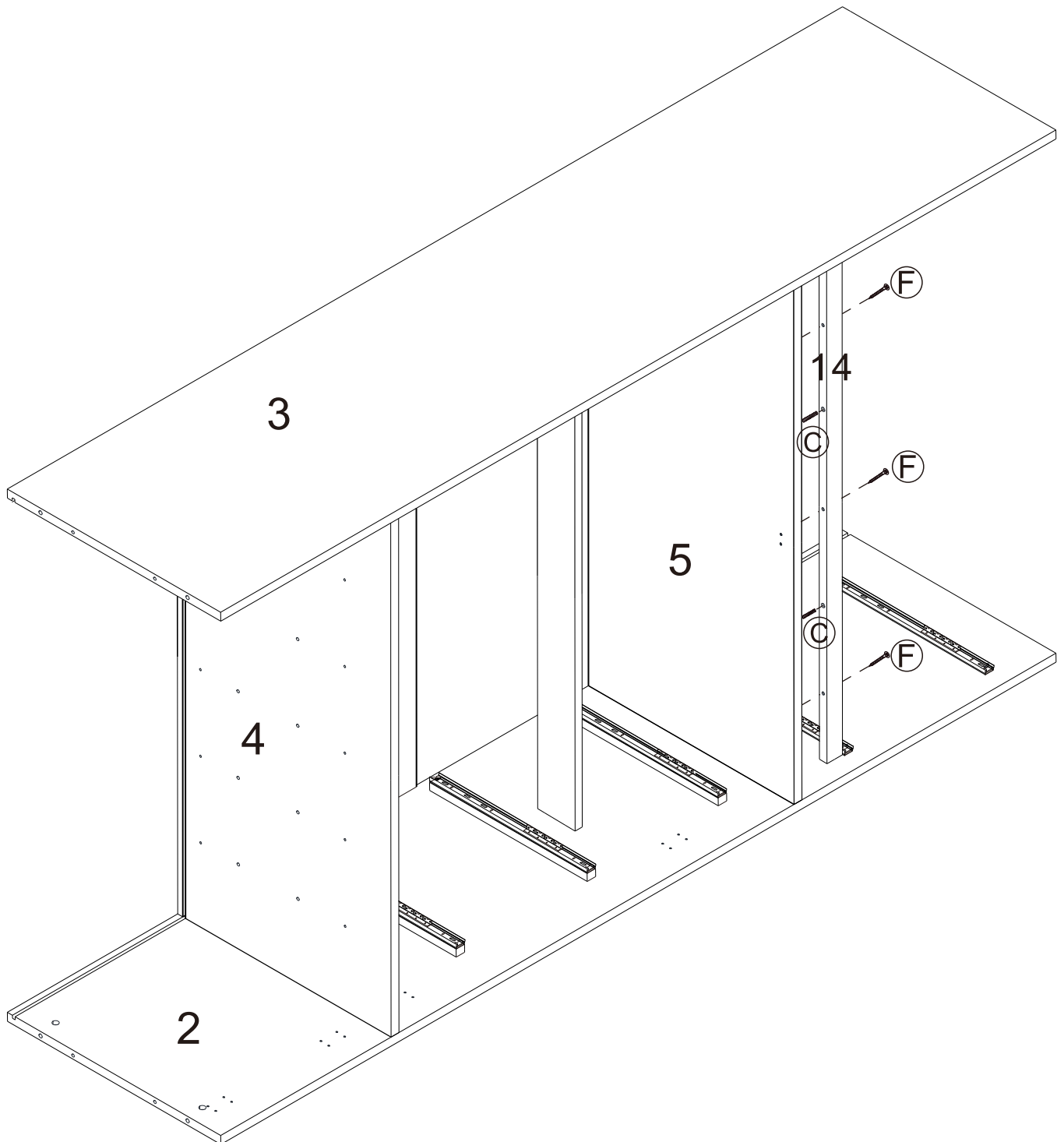

Step 12  
Étape

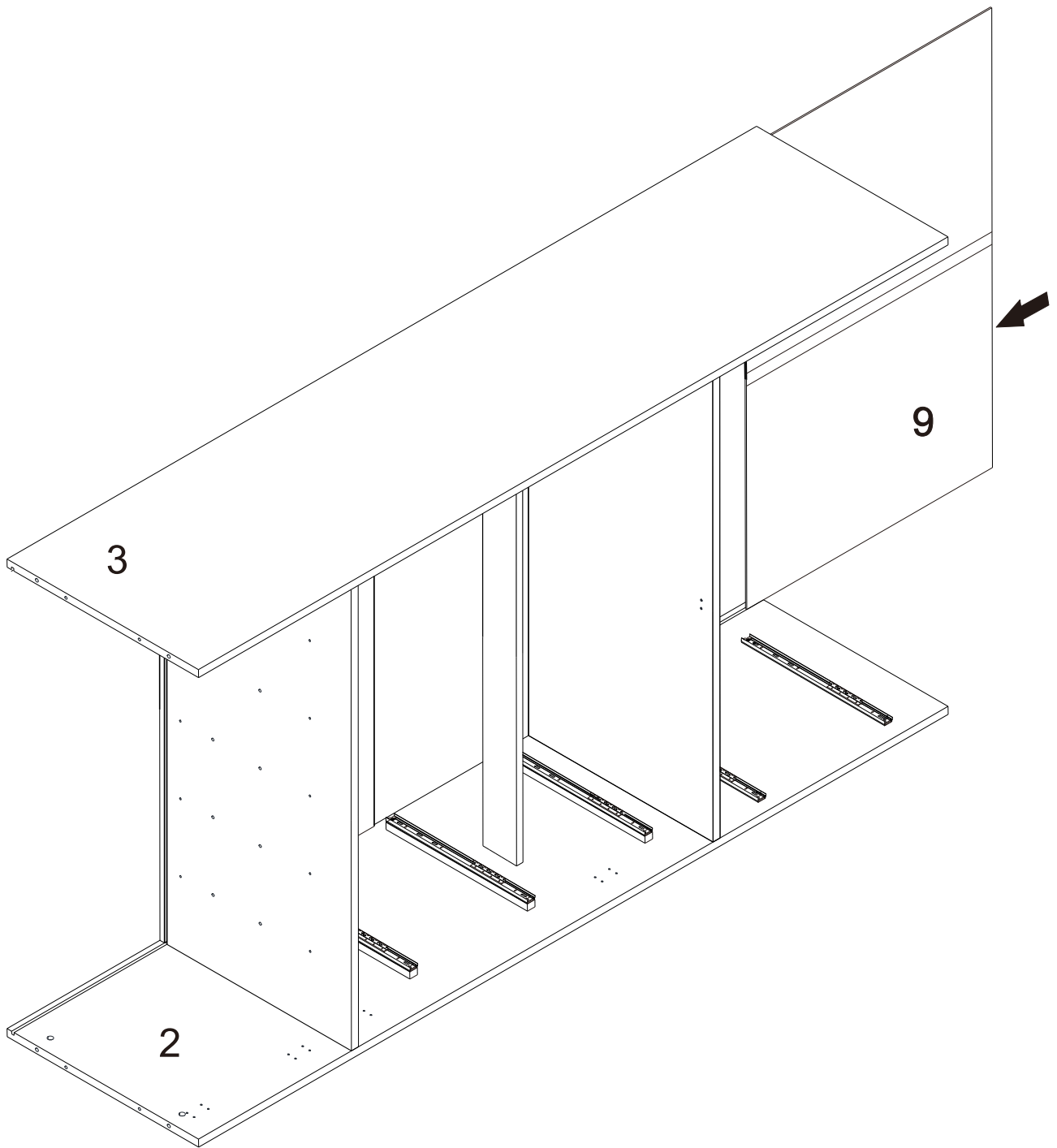

Step 13  
Étape

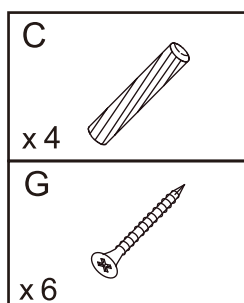
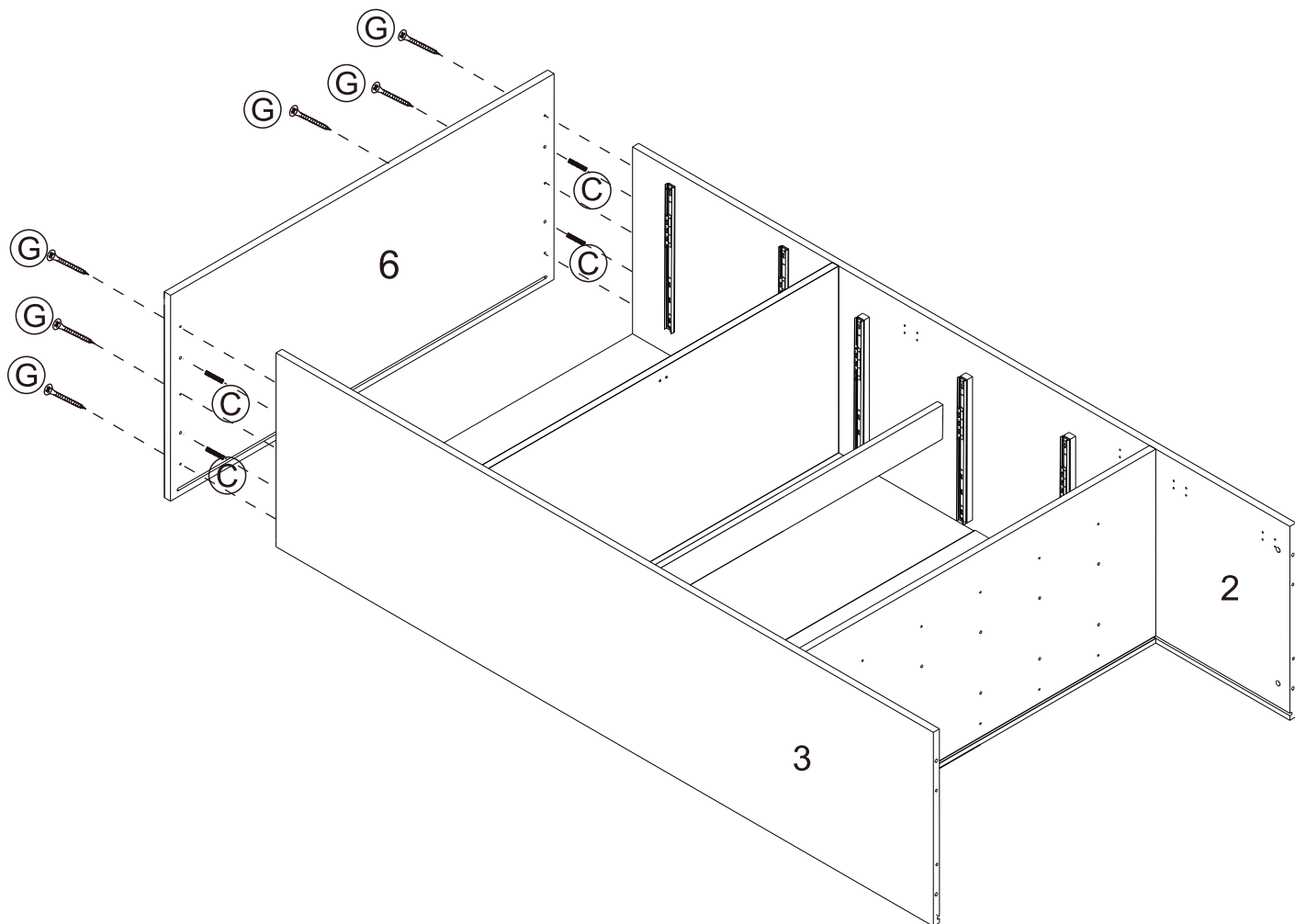

Step 14  
Étape

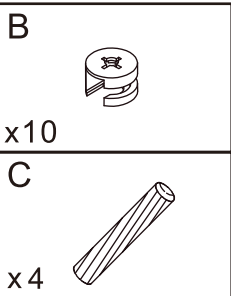
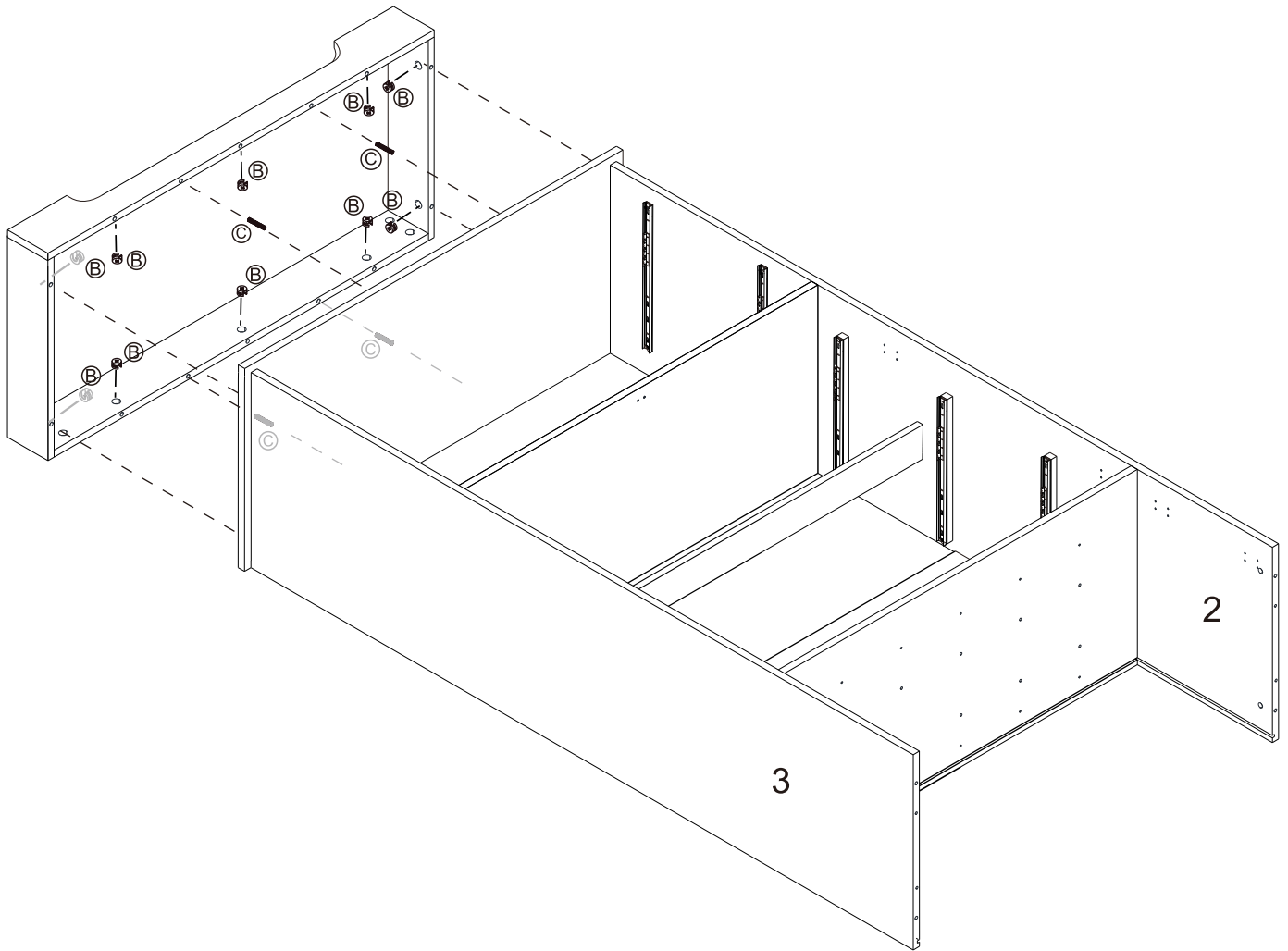

Step 15  
Étape

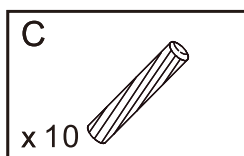
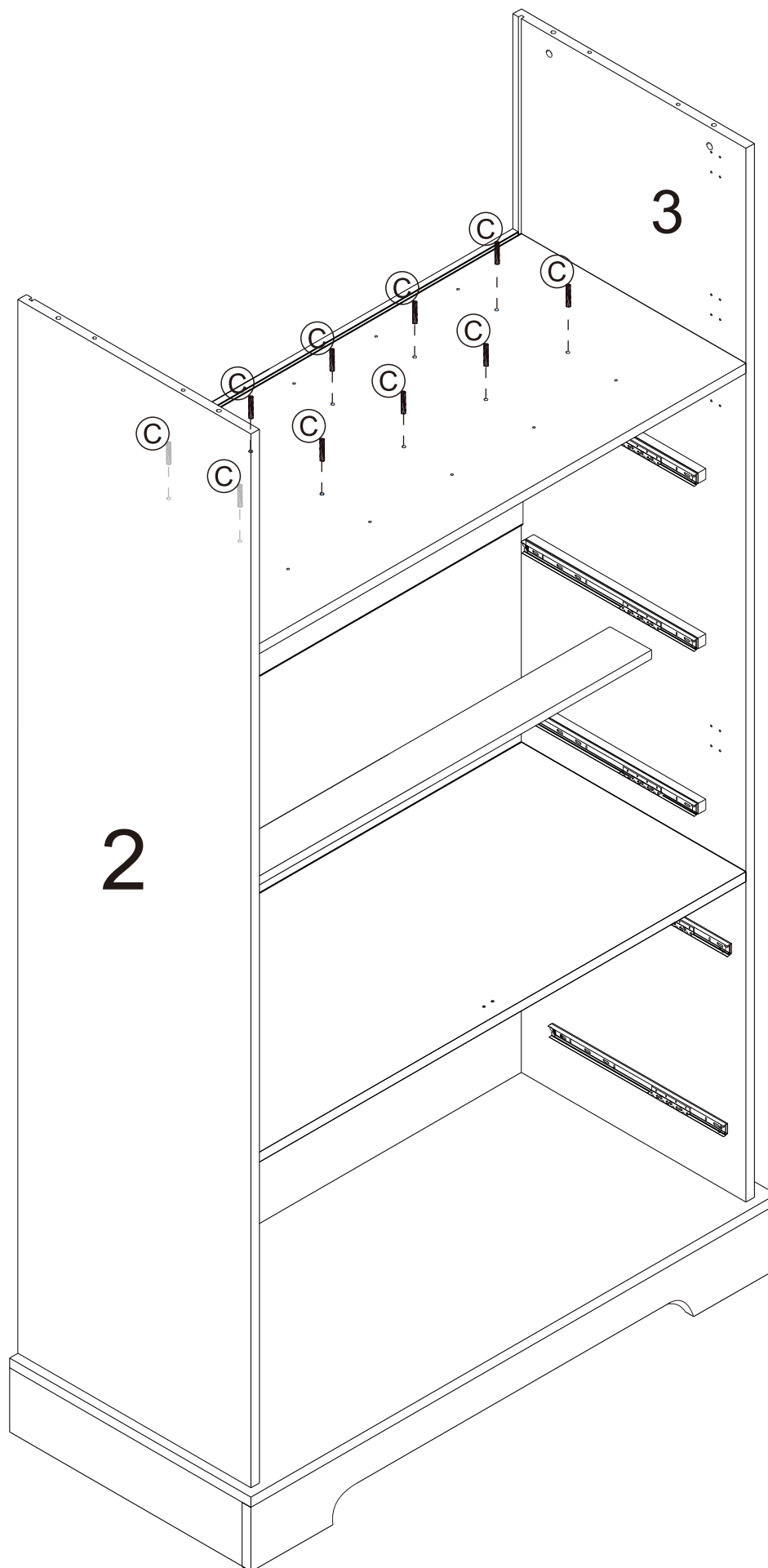

Step 16  
Étape

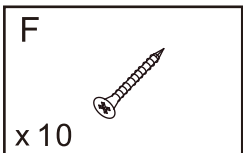
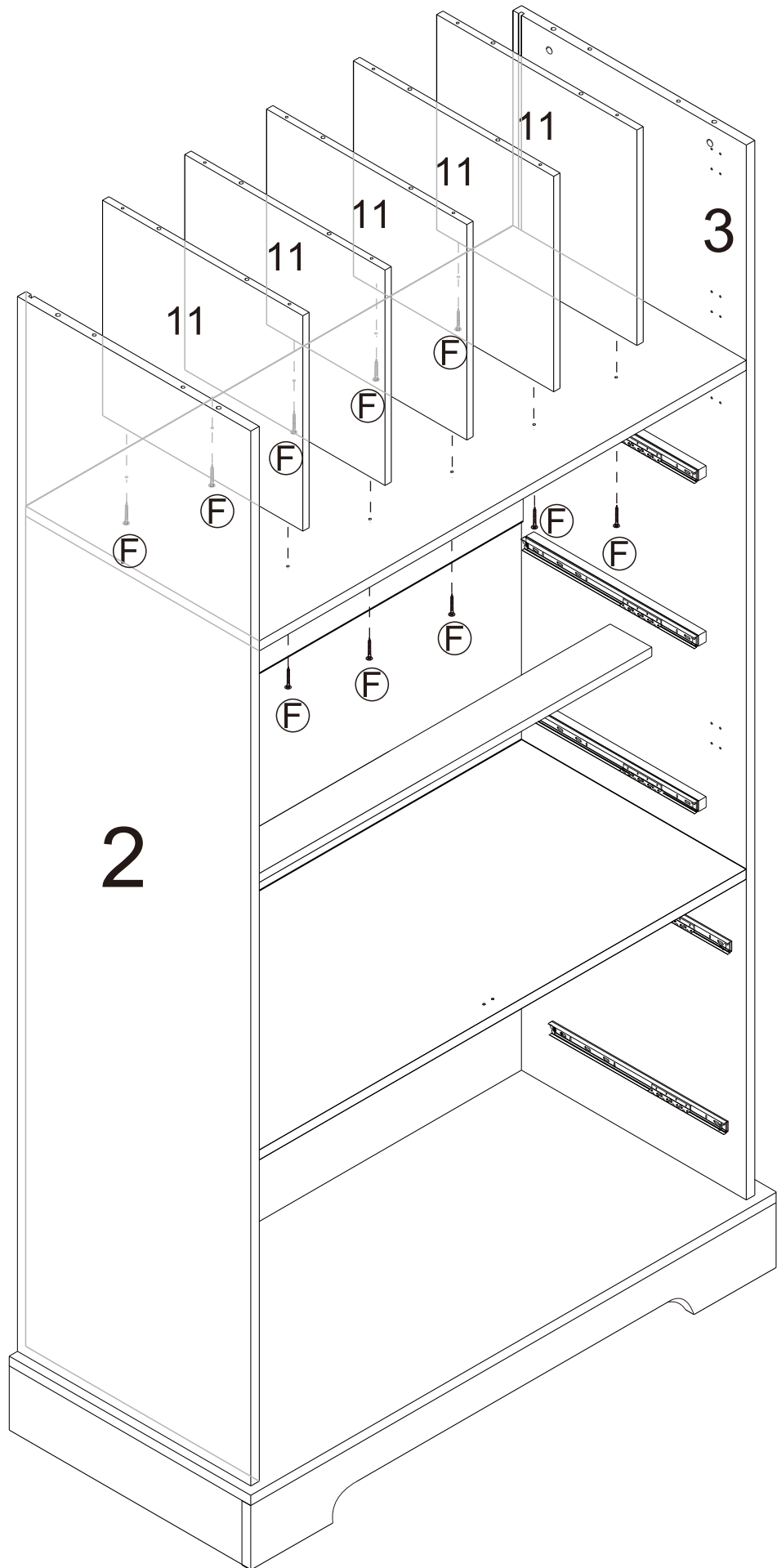

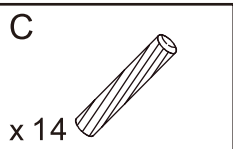
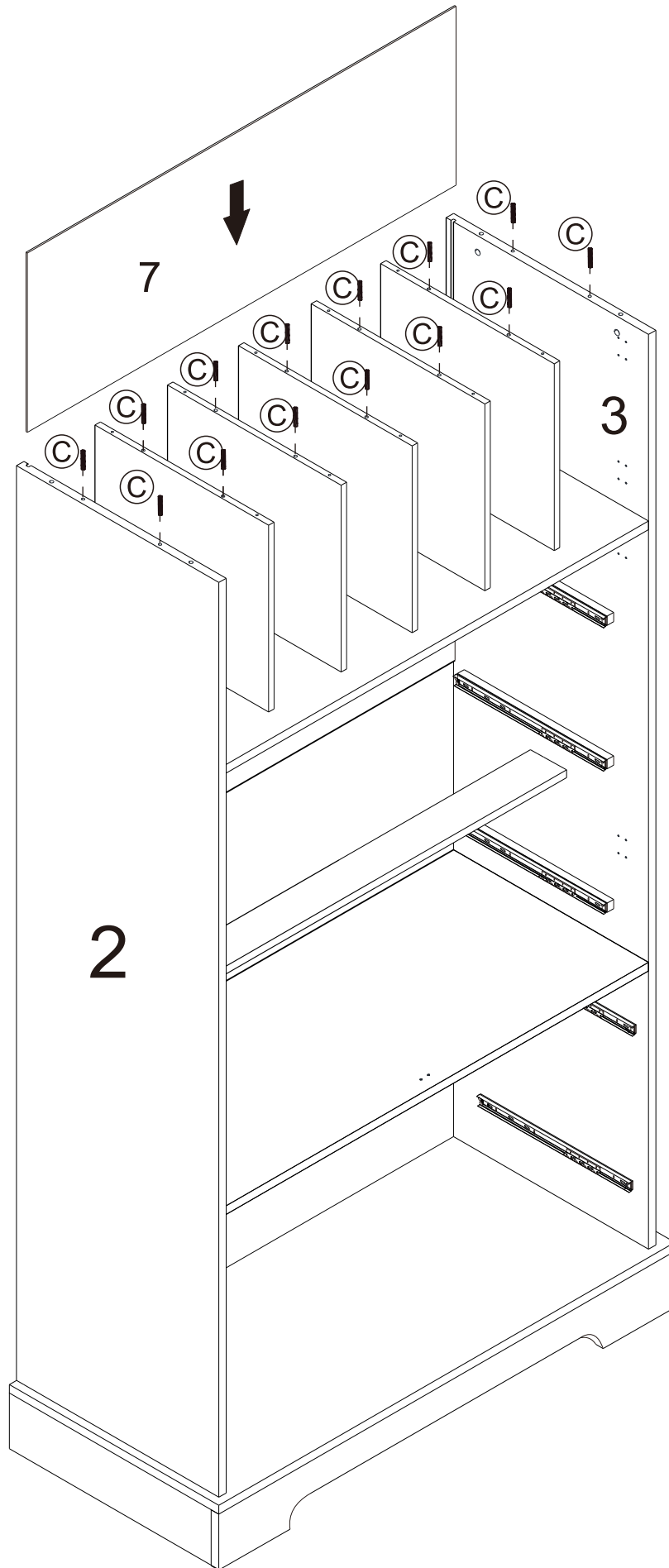

Step 17  
Étape

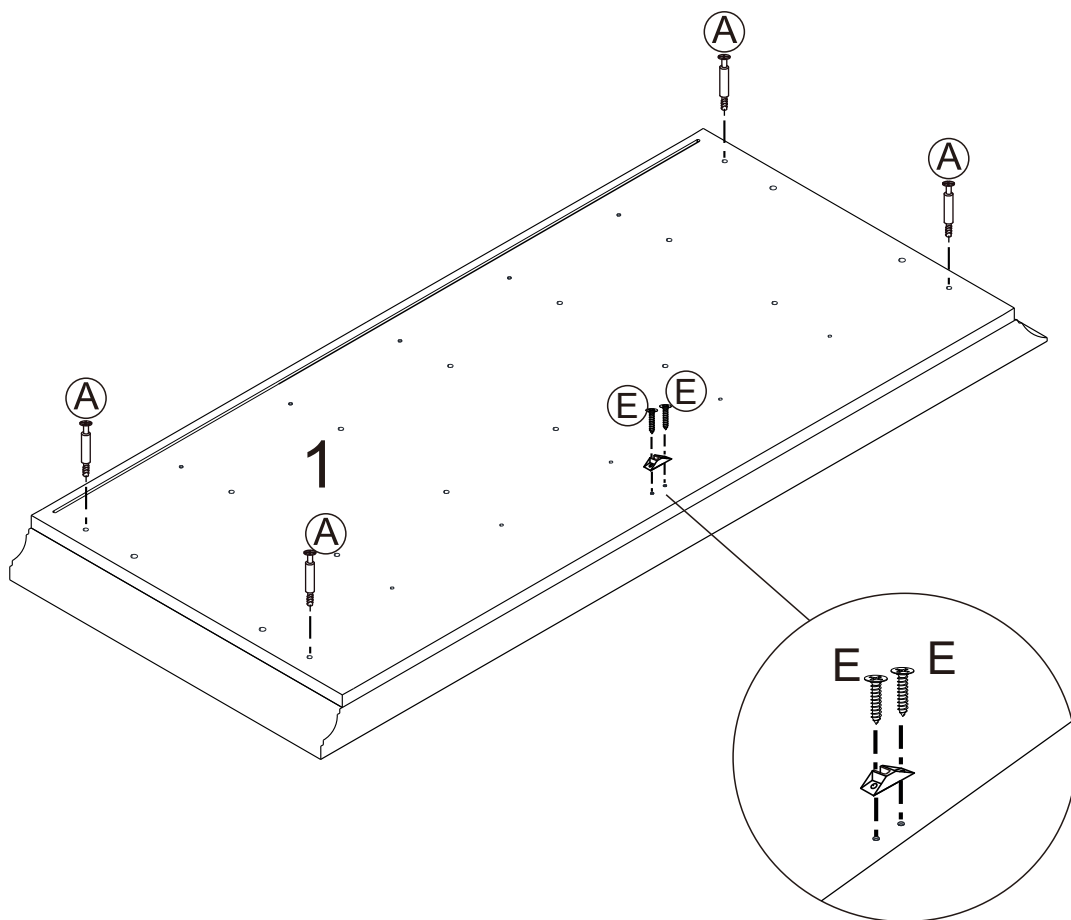

Step 18  
Étape

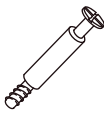

A	
x4	
E	
x2	
L	
x1	

Step 19  
Étape

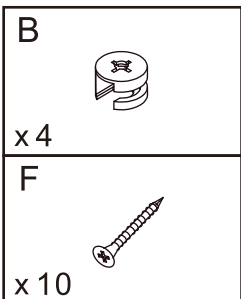
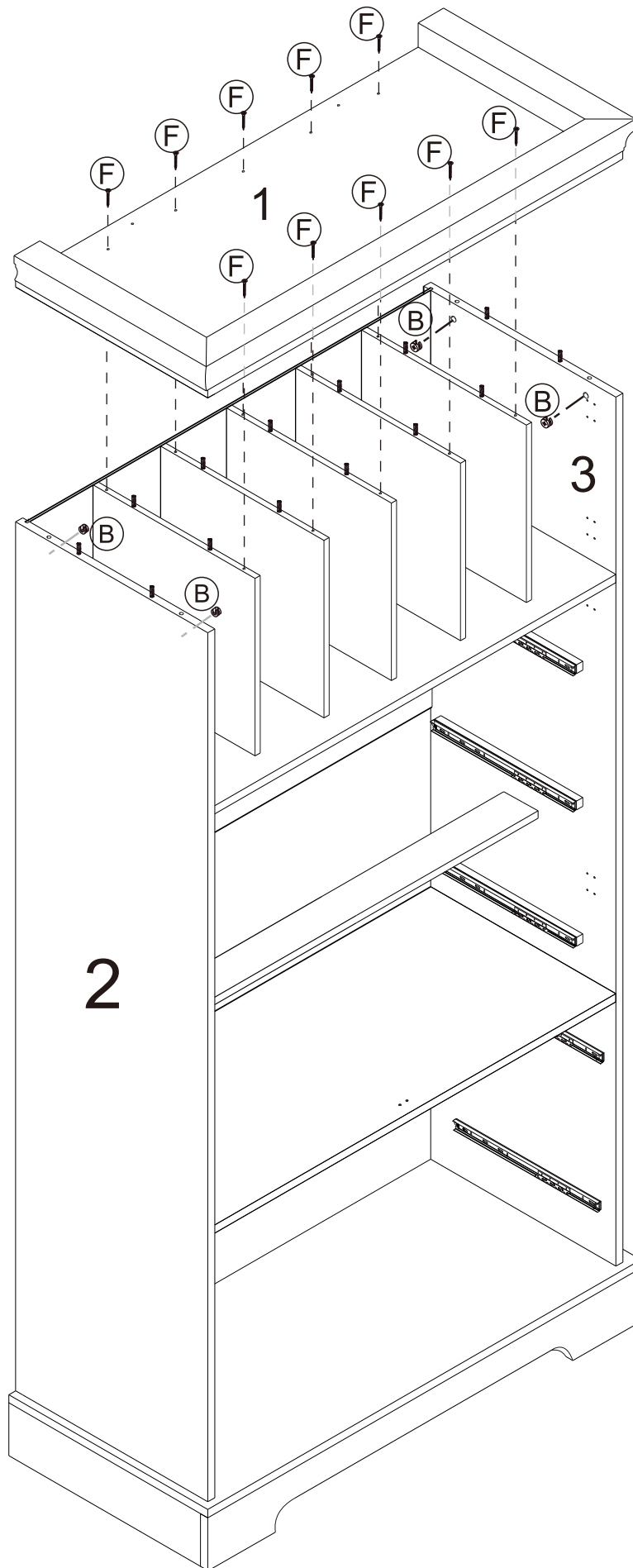

Step 20  
Étape

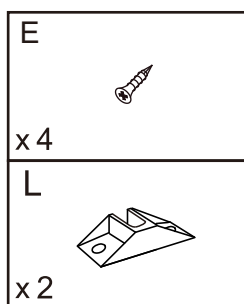
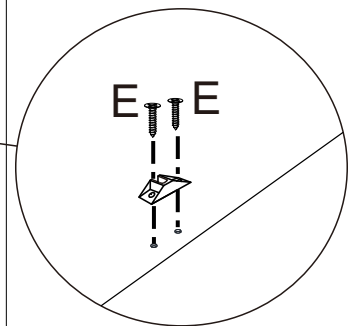
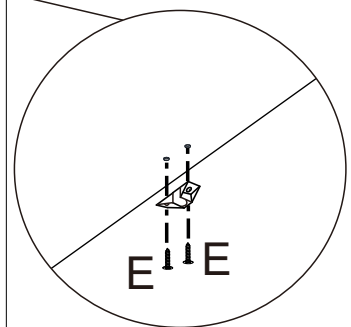
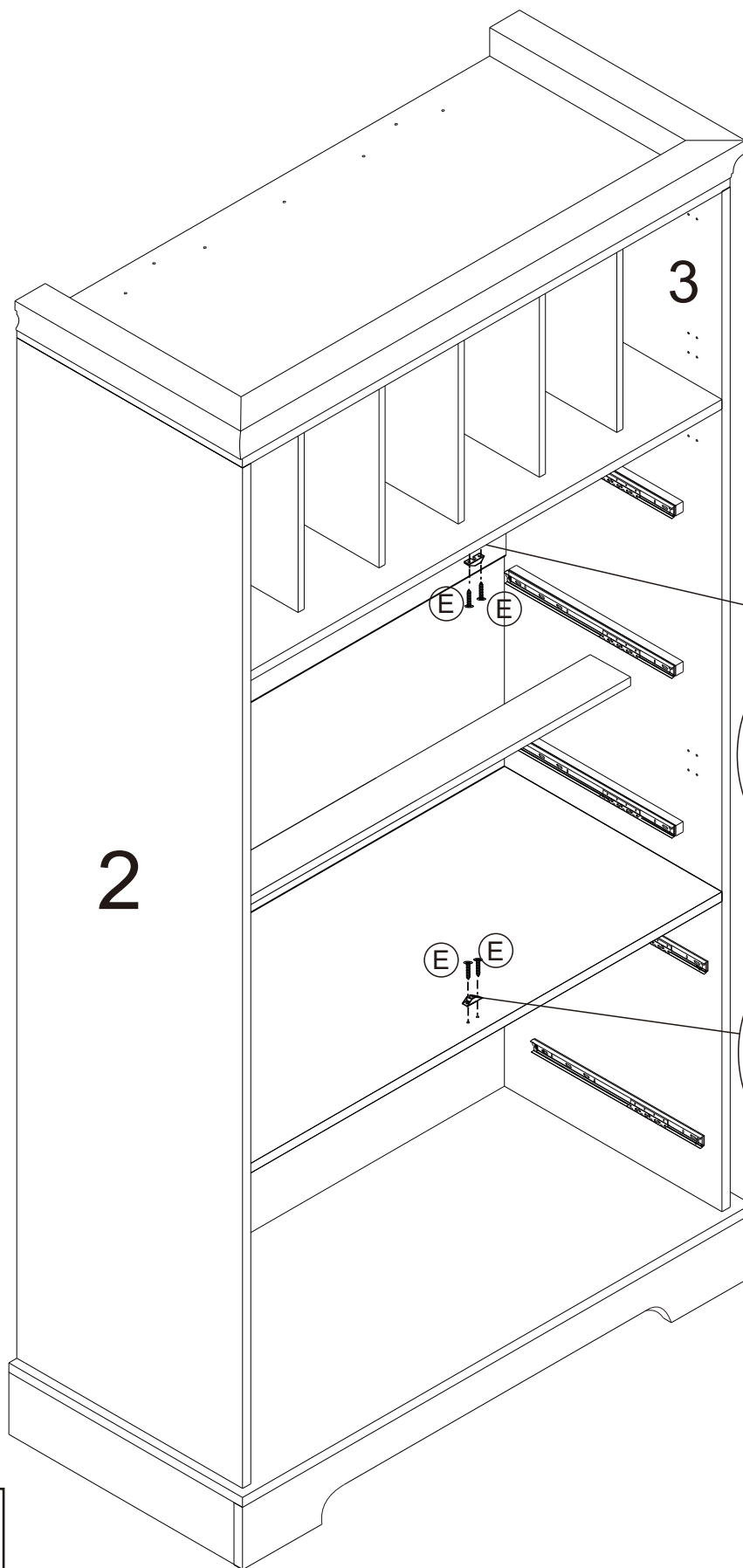

Step 21  
Étape

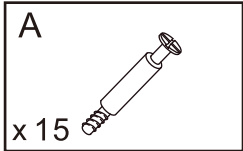
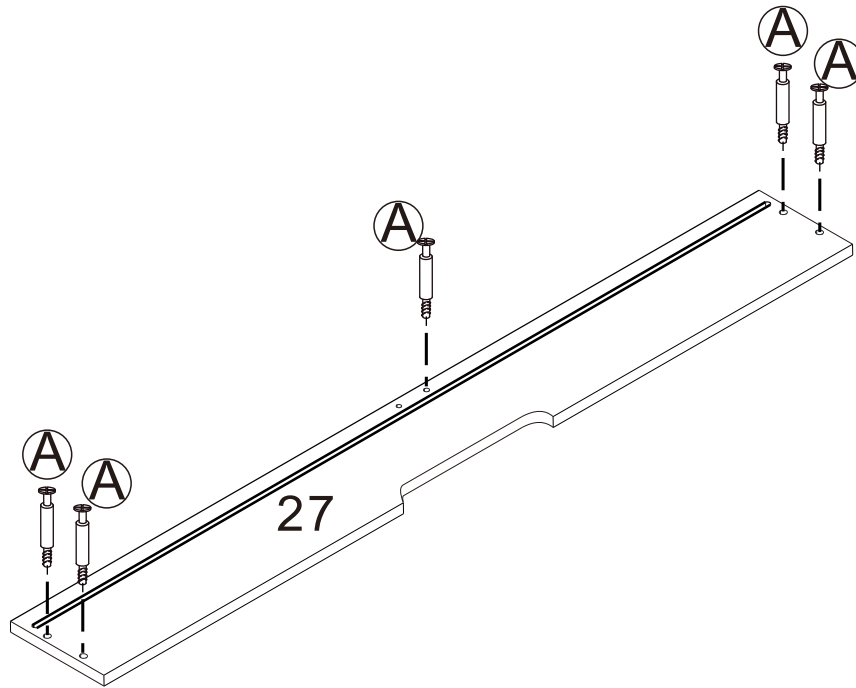

x 3

Step 22  
Étape

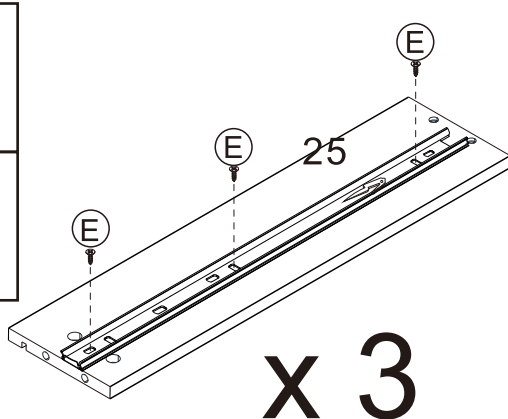
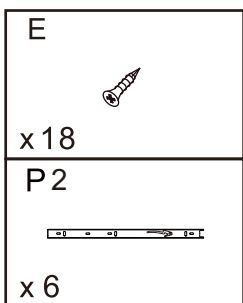
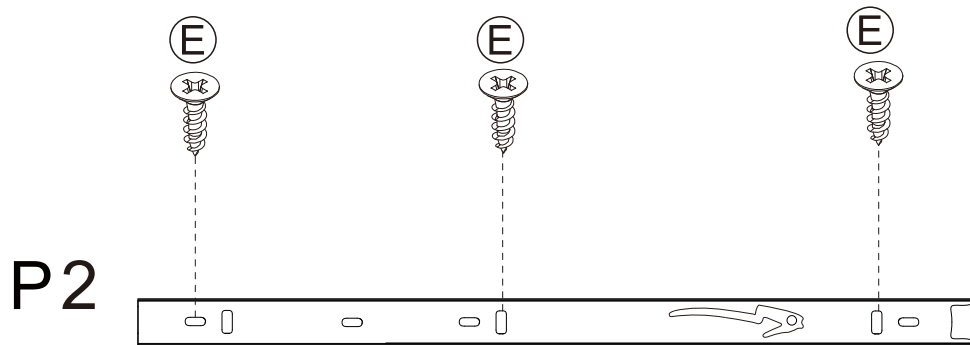

x 3

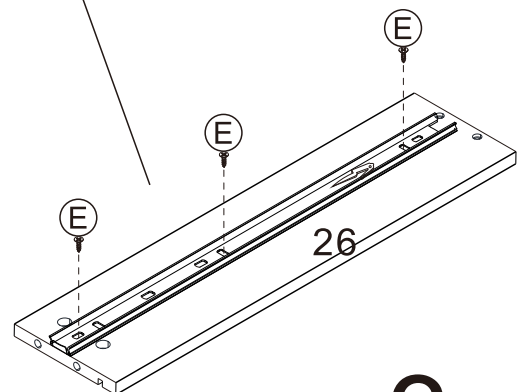

x 3

Step 23  
Étape

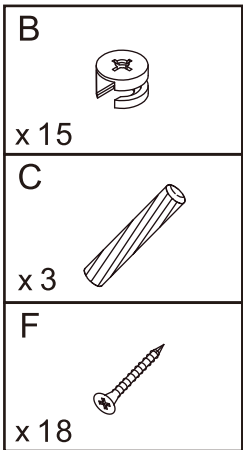
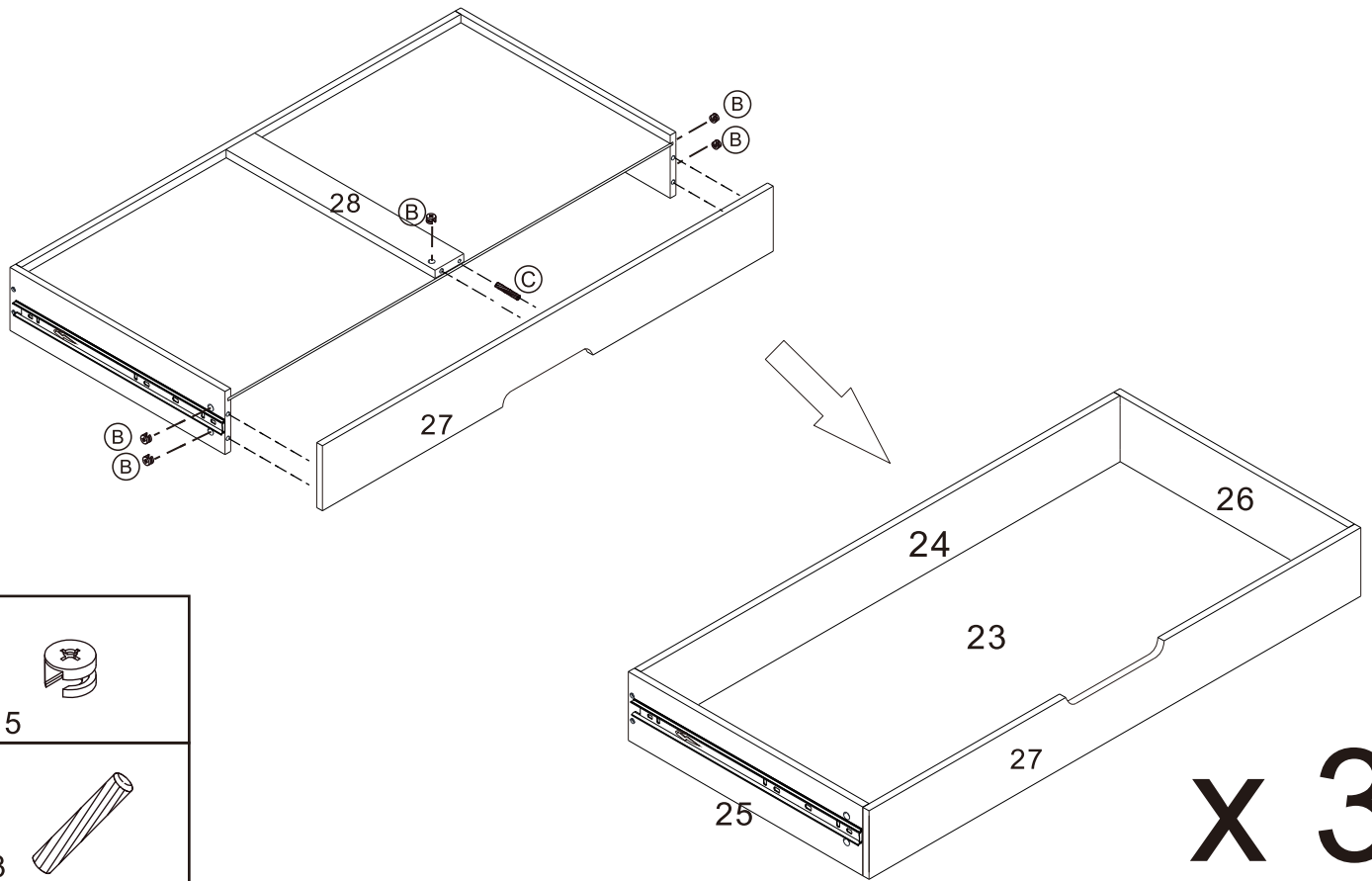
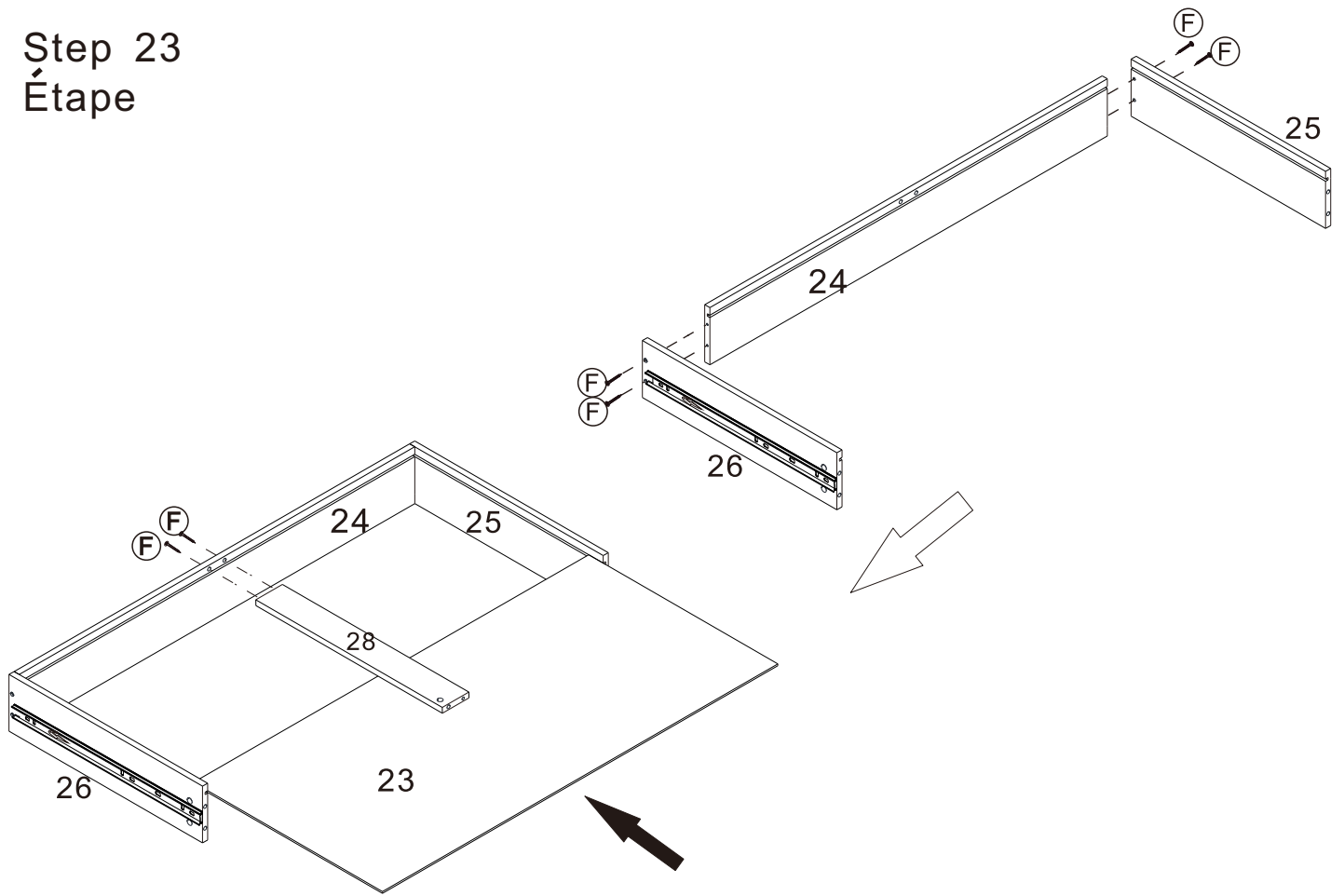

**x 3**

P27

Step 24  
Étape

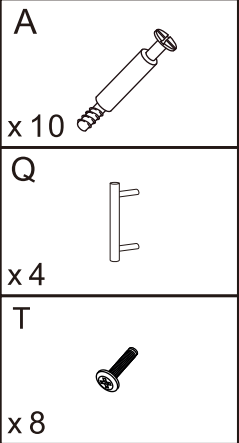
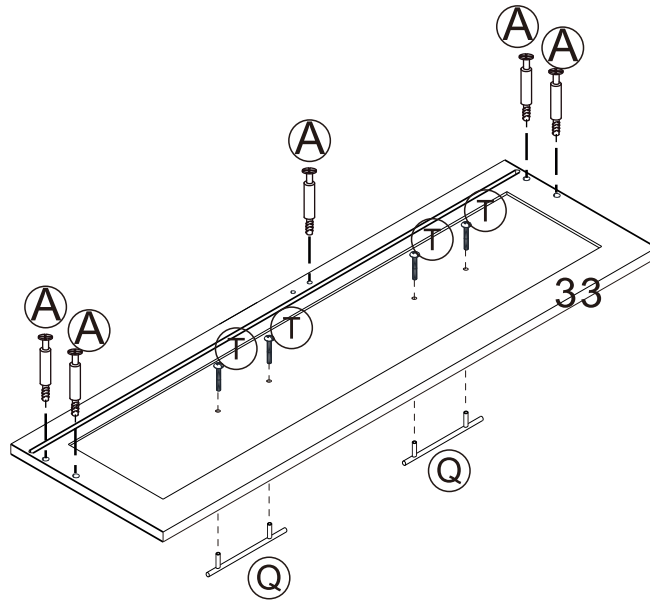

x 2

Step 25  
Étape

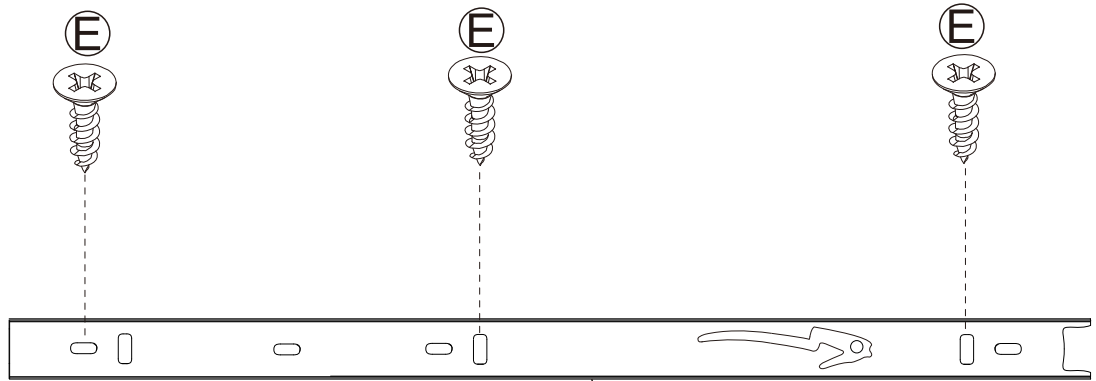

P2

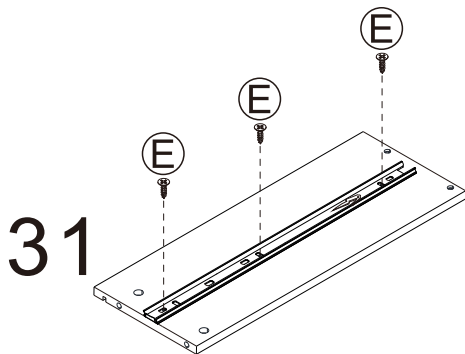

x 2

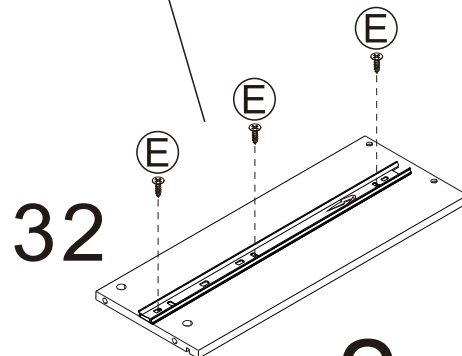

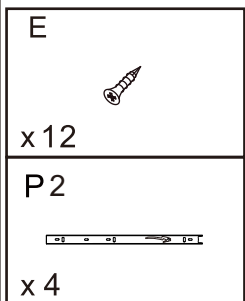

x 2



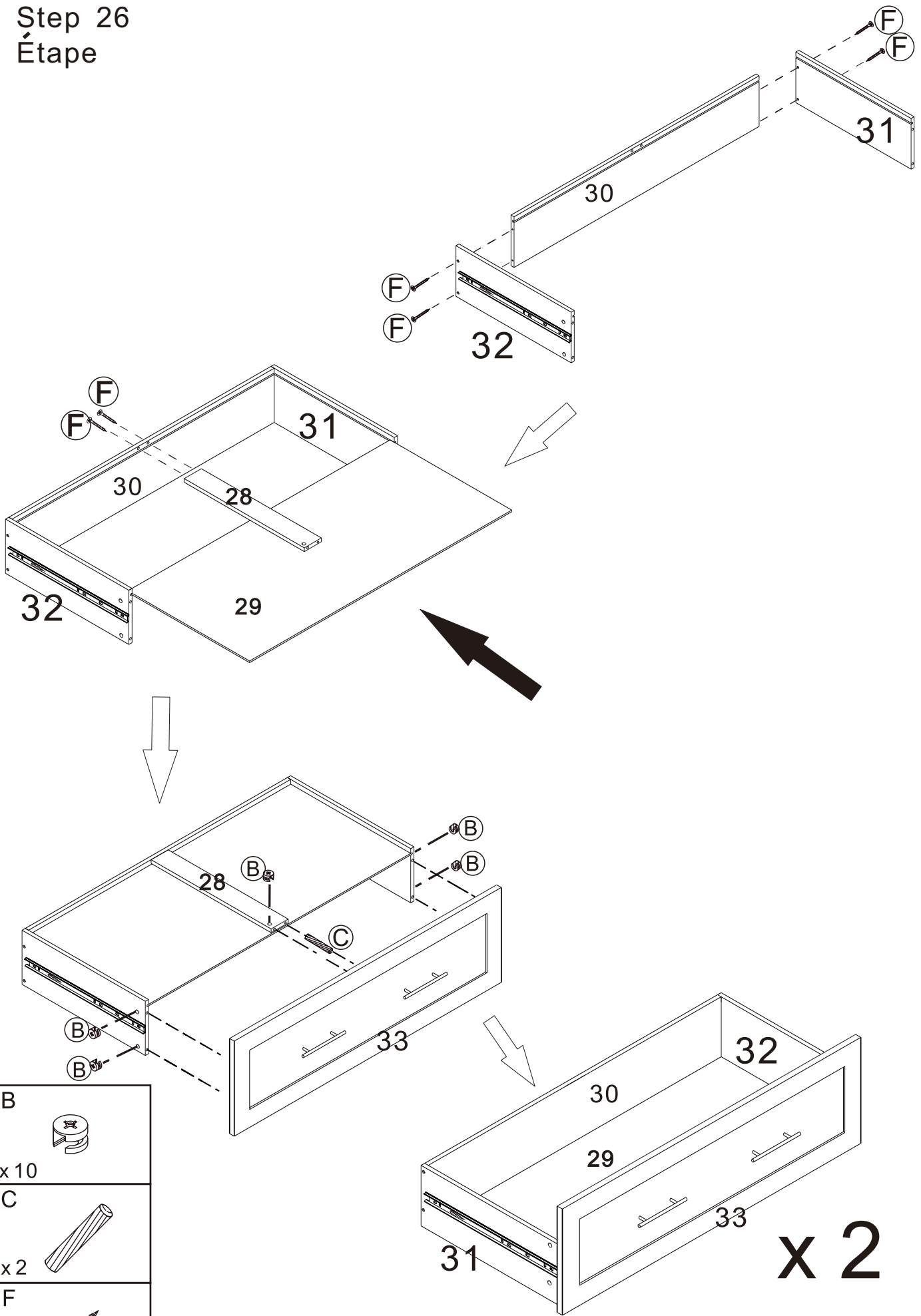

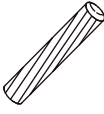

Step 26  
Étape





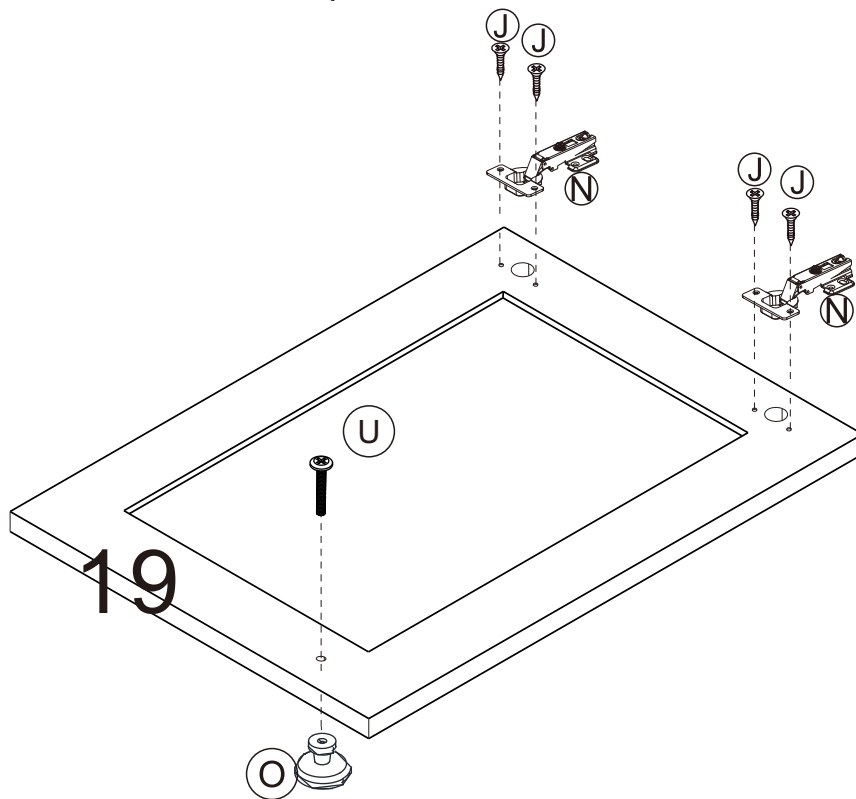
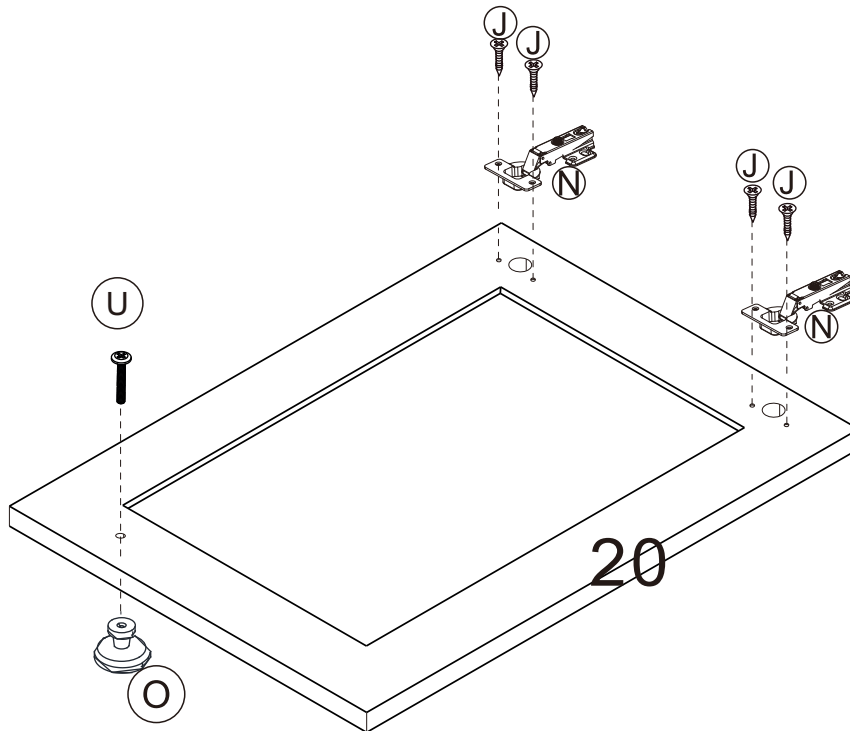

- B**  
x 10  

- C**  
x 2  

- F**  
x 12  

Step 27  
Étape

U	
x 2	
J	
x 8	
N	
x 4	
O	
x 2	



Step 28  
Étape

I	
x4	
J	
x8	
N	
x4	
R	
x2	

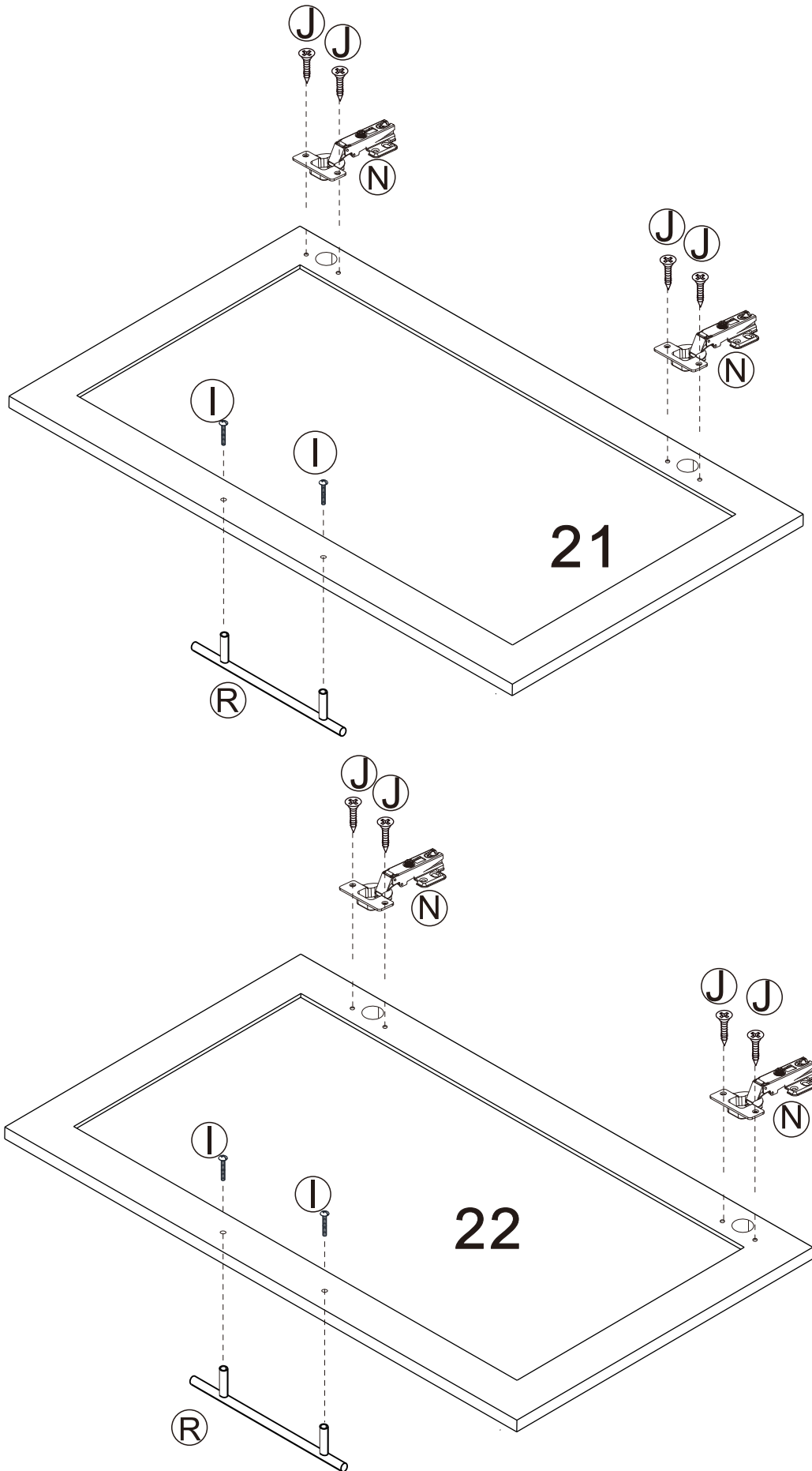

Step 29  
Étape

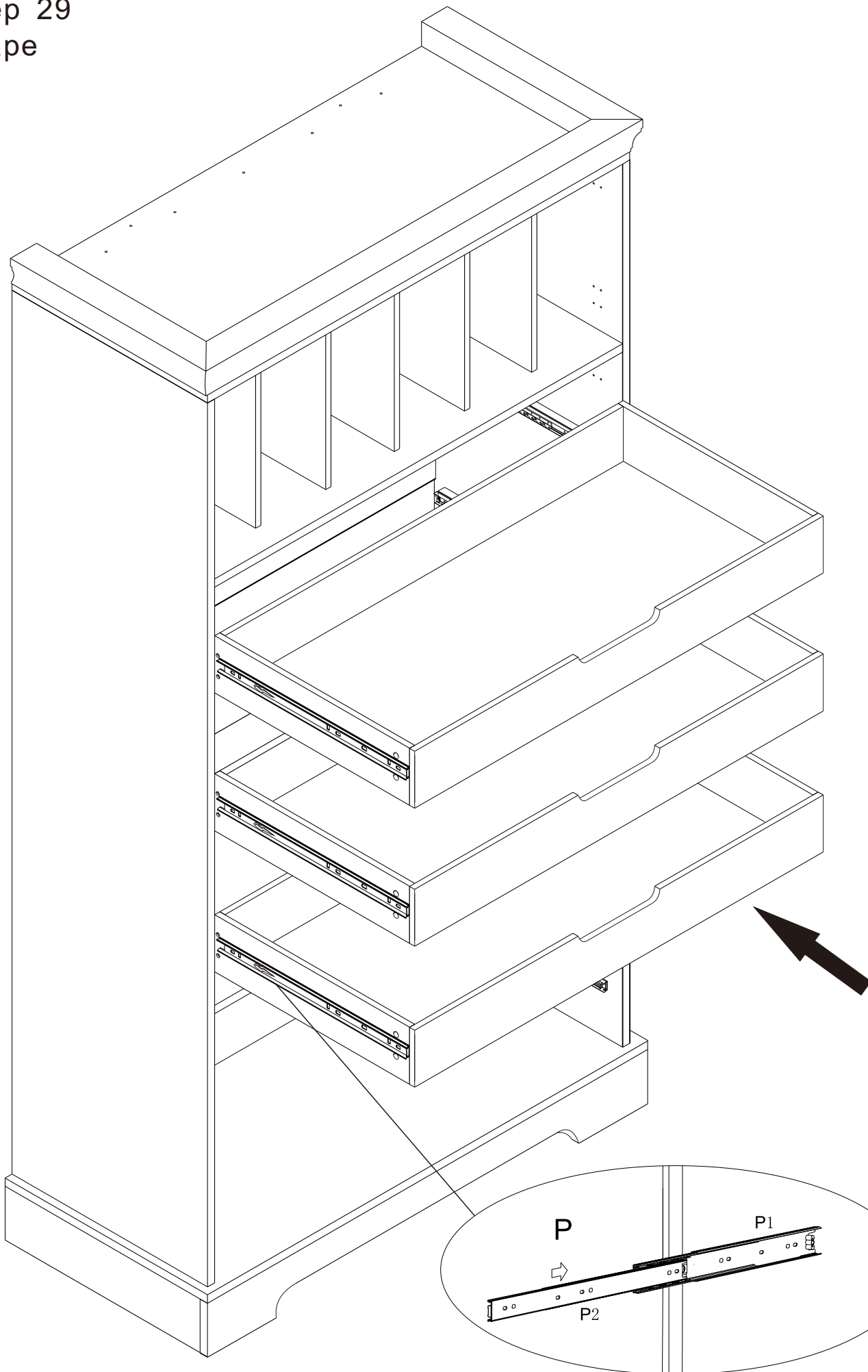

Step 30  
Étape

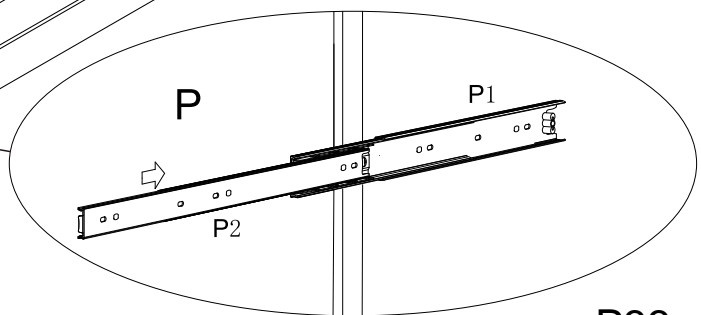
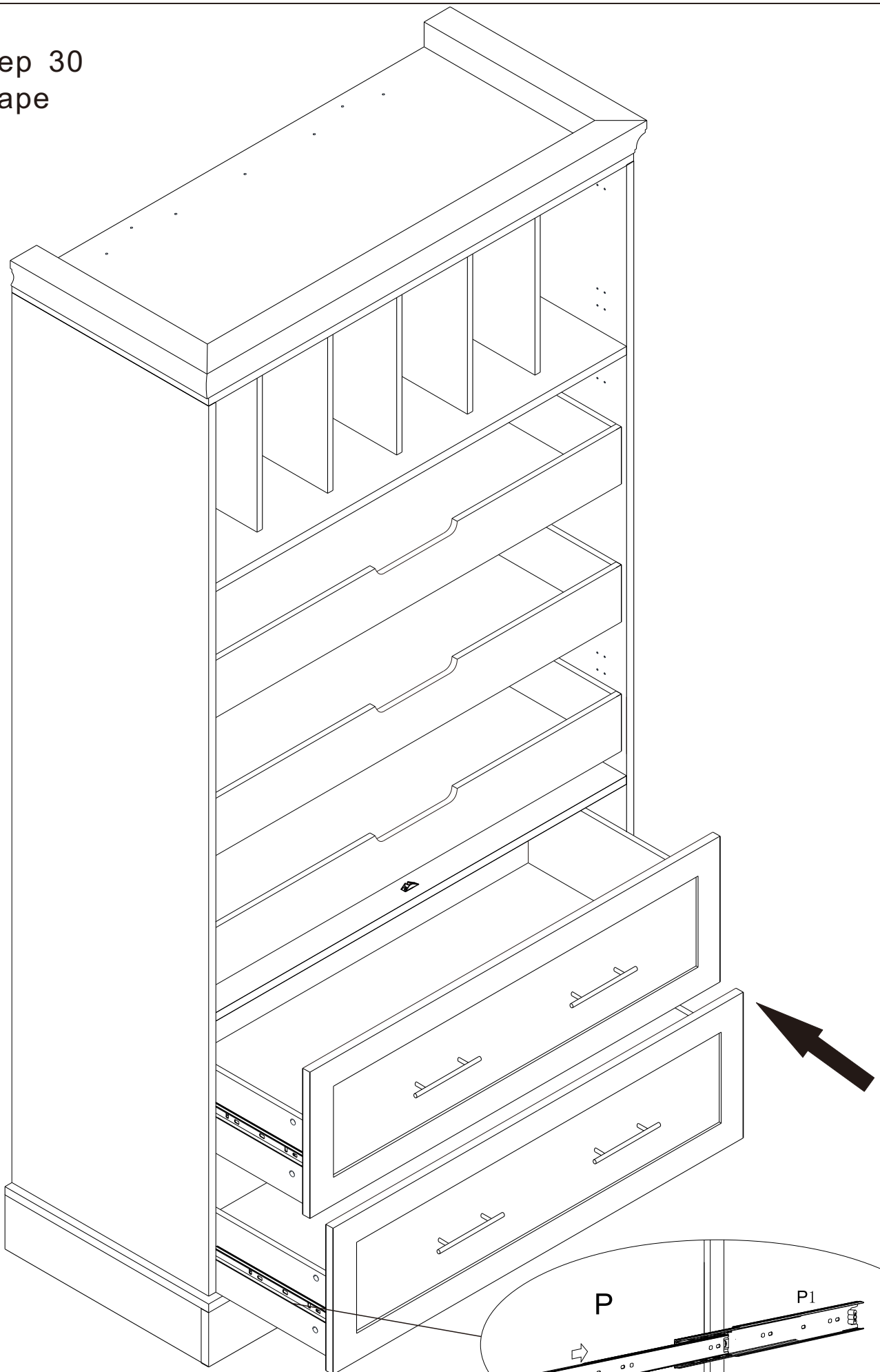

Step 31  
Étape

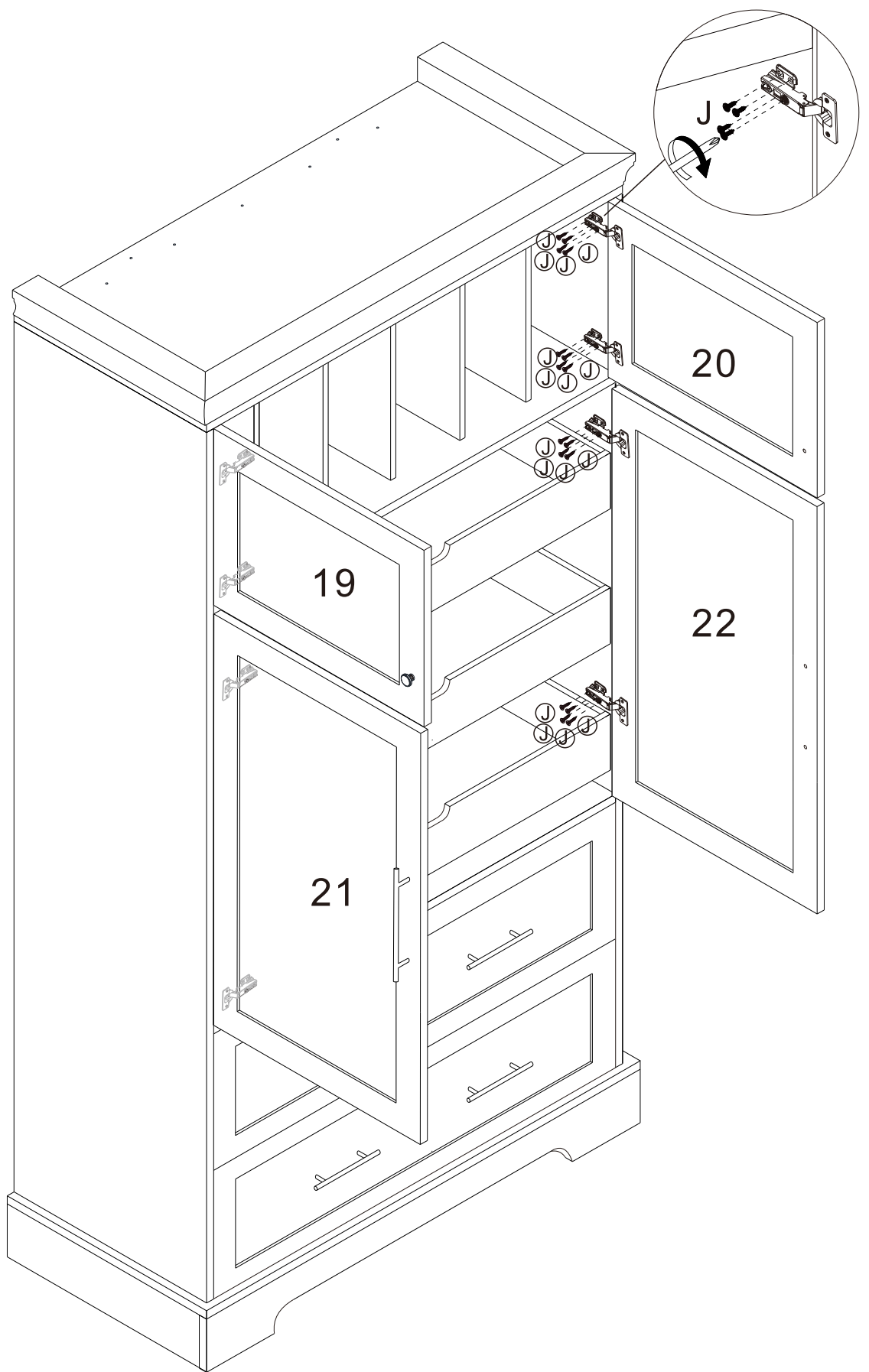
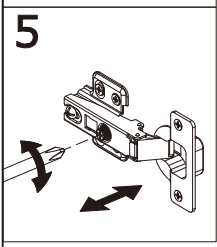
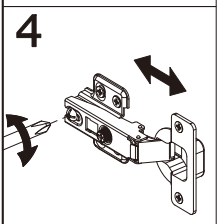
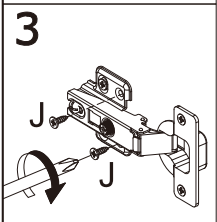
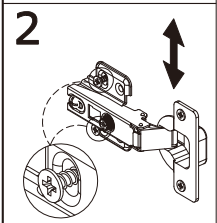
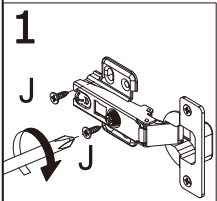

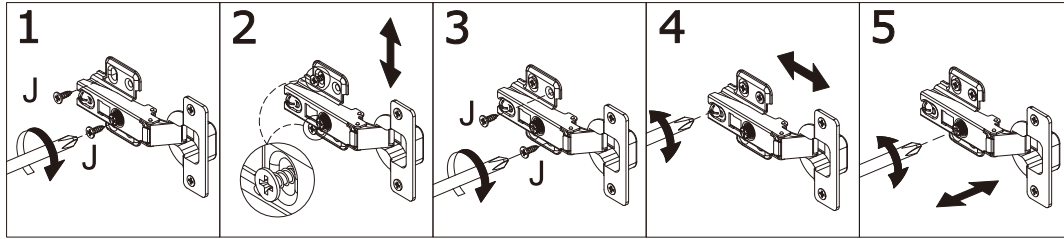

#### 1. Positioning the Hinge:

Align the hinge (marked as J) with the pre-drilled holes on the cabinet side panel and door. Secure the hinge to the cabinet using the provided screws at the designated mounting points.

#### 2. Height Adjustment:

Loosen the screws at points to adjust the vertical position of the door. Tighten them once the desired height is achieved.

#### 3. Depth Adjustment:

Use the adjustment point marked to fine-tune the door's inward or outward position relative to the cabinet.

#### 4. Horizontal Alignment:

Adjust the screw at position J (near the center) to shift the door left or right for proper alignment.

#### 5. Damping Mechanism Engagement:

Ensure the damping mechanism (not explicitly labeled but implied) is properly engaged with the hinge arm for smooth closing.

#### 6. Final Check:

Open and close the door to verify smooth operation. Re-adjust if necessary.

Voici la traduction en français des instructions :

#### Positionnement de la charnière

Alignez la charnière (marquée J) avec les trous pré-perçés sur le panneau latéral du meuble et la porte. Fixez la charnière au meuble à l'aide des vis fournies aux points de montage désignés.

#### Réglage en hauteur

Desserrer les vis aux points indiqués pour ajuster la position verticale de la porte. Reserrer une fois la hauteur souhaitée obtenue.

#### Réglage en profondeur

Utilisez le point de réglage marqué pour affiner la position de la porte (vers l'intérieur ou l'extérieur) par rapport au meuble.

#### Alignement horizontal

Ajustez la vis au niveau de la position J (près du centre) pour déplacer la porte vers la gauche ou la droite afin d'obtenir un alignement correct.

#### Mise en place de l'amortisseur

Assurez-vous que le mécanisme d'amortissement est correctement engagé avec le bras de la charnière pour une fermeture en douceur.



#### Vérification finale

Ouvrez et fermez la porte pour vérifier le bon fonctionnement. Réajuster si nécessaire.

N'hésitez pas à me demander si vous souhaitez adapter certains termes ou ajouter des précisions techniques.

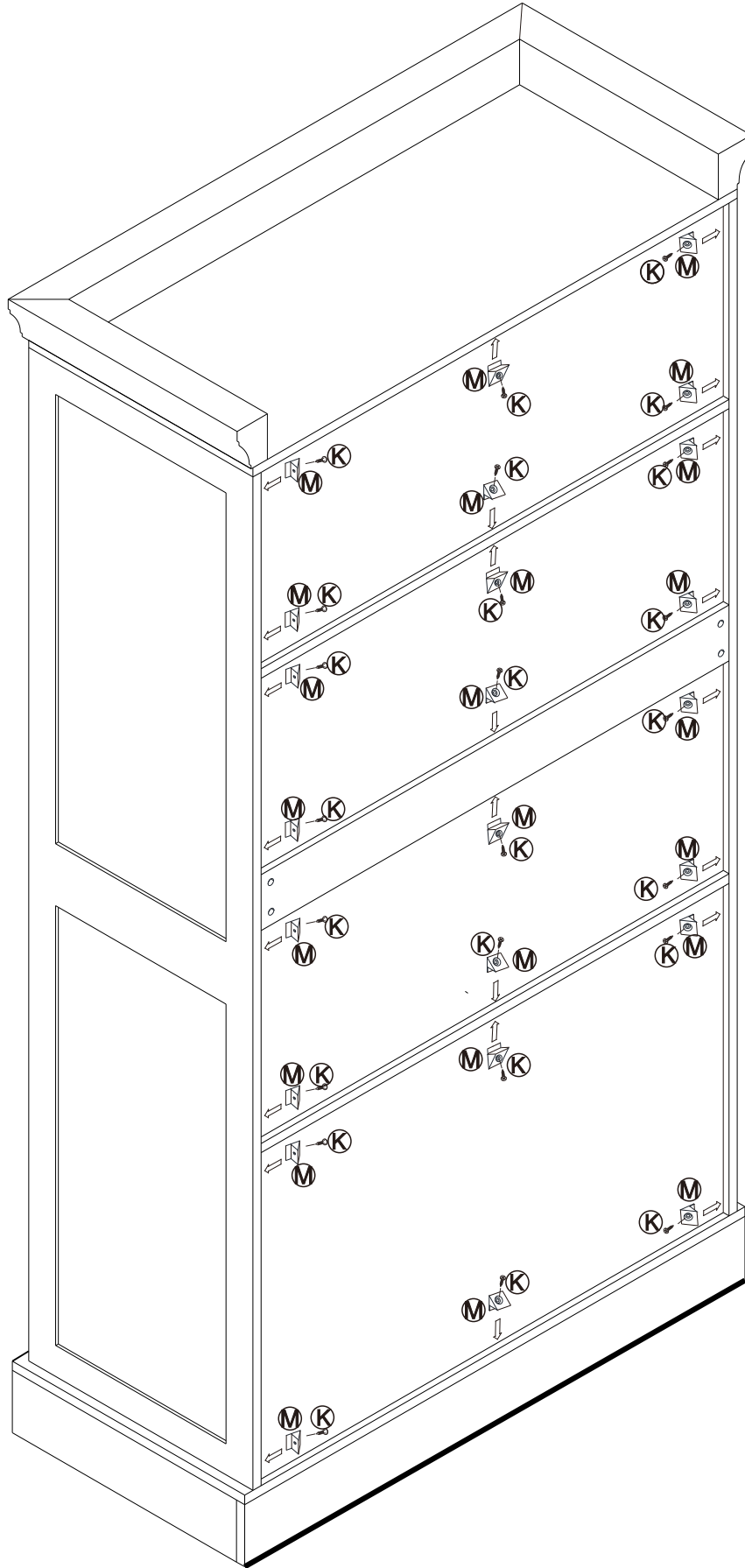
Step 32  
Étape



K	
x 24	
M	
x 24	

Step 33  
Étape

