

6 Pcs Sofa Set

Instructions

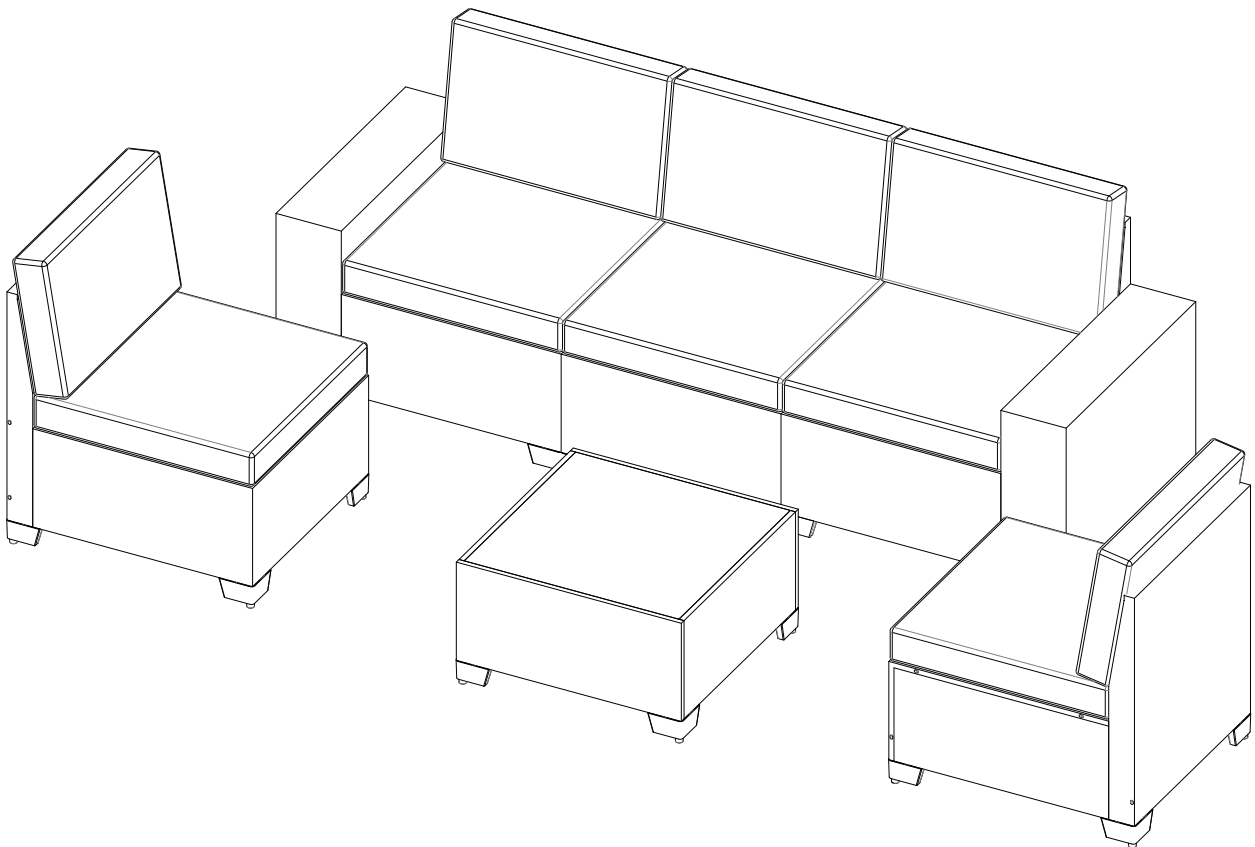

Model:06SF23-FB or 06SF23-FB-NW

IMPORTANT

Please make a decision which model you want to put modules together, because you have to use different parts to make it either a corner sofa or an armless sofa.

Option 1: Seat Part(6ST)+Back Part(6BK)+Side Part(6SD) can be assembled as the third armless sofa, then you can put them together as living sofa set model(Figure a).

Option 2: Seat Part(6ST)+Back Part(6BK)+Long Back Part(6LB), can be assembled as the corner sofa, then you can put them together as corner sofa set model(Figure b).

Option 1

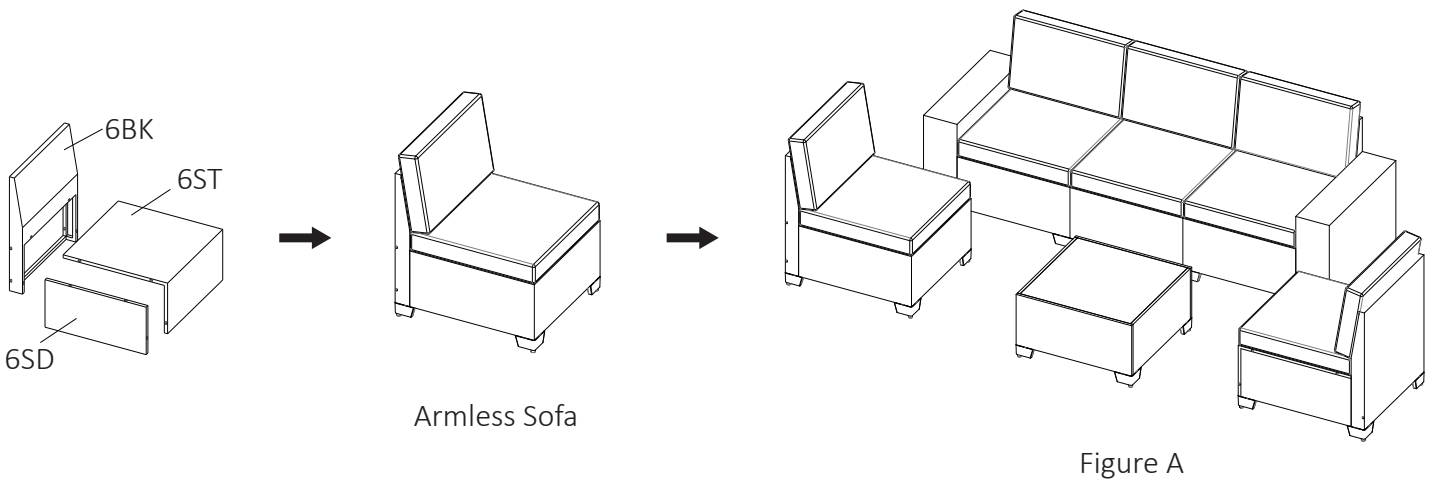

6 Pcs Living Sofa Model

Option 2

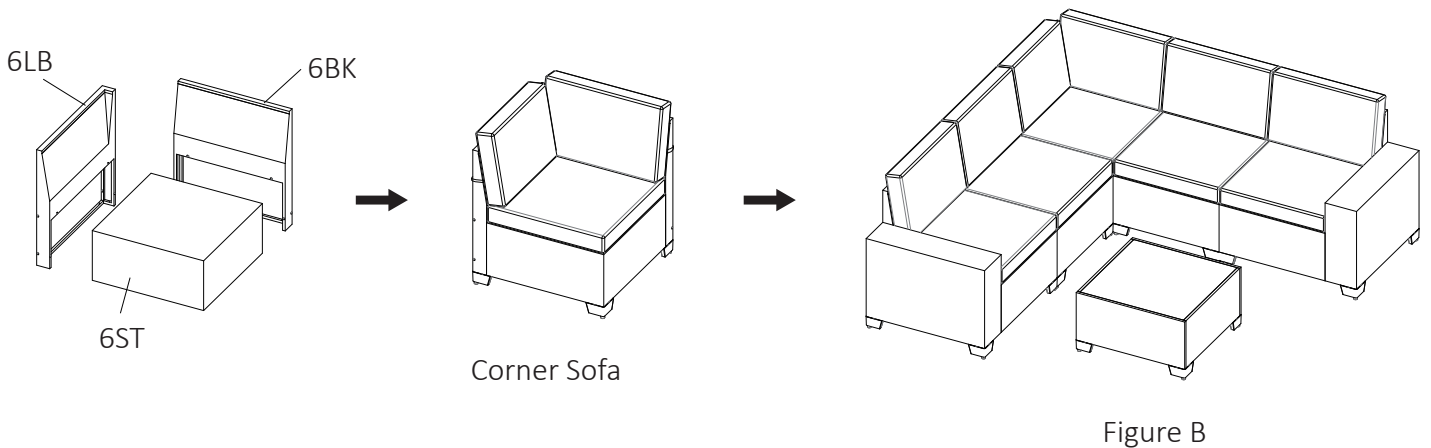

6 Pcs Corner Sofa Model

Care & Instructions

Thank you for ordering the 6 pcs sofa set, here are some tips which may help you:

1. This 6pcs sofa set comes in 3 boxes. If you only receive 1 box or 2 boxes, please do not worry. The others will arrive very soon.

2. Carton A+Carton B: Mixed contains everything except the cushion covers. Carton C only contains the cushion covers.

3. The cushions are vacuum packed, after you open the package, they will fully return to the original thickness after a while.

4. Amazon only allows us to upload 1 tracking number. If you want to know the others' tracking numbers, please contact us.

5. If any part is damaged or missing (please refer to packing list on page 5~6), please feel free to contact us. We will send you the replacement immediately.

6. In order to prolong the sofa set's service life, we suggest that you put all the cushions indoor on a rainy day.

7. We hope you can enjoy our product, if you have any other problem, please feel free to contact us.

Contact US:

Service@alaulm.com

www.alaulm.com

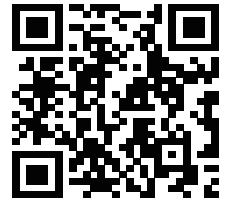

How To Cover Holes & Repair Broken Wicker



Step 1



Step 2



Step 3



Step 4

You can use two pieces PE wicker to cover the hole, and repeat the steps to cover all the holes. These PE wicker can also be used to repair the scratch or broken wicker.

Catalog

Important.....	01
Care & Instructions	02
How to Cover Holes & Repair Broken Wicker.....	02
How to Assemble U-Shaped Connector.....	04
How to Assemble End Cap.....	04
Parts List of Box A	05
Parts List of Box C.....	05
Parts List of Box B	06
Packing List	07
How to Assemble Armless Sofa	08
How to Assemble Left Arm Sofa	10
How to Assemble Right Arm Sofa	12
How to Assemble Corner Sofa	14
How to Assemble Coffee Table	16

U-Shaped Connector

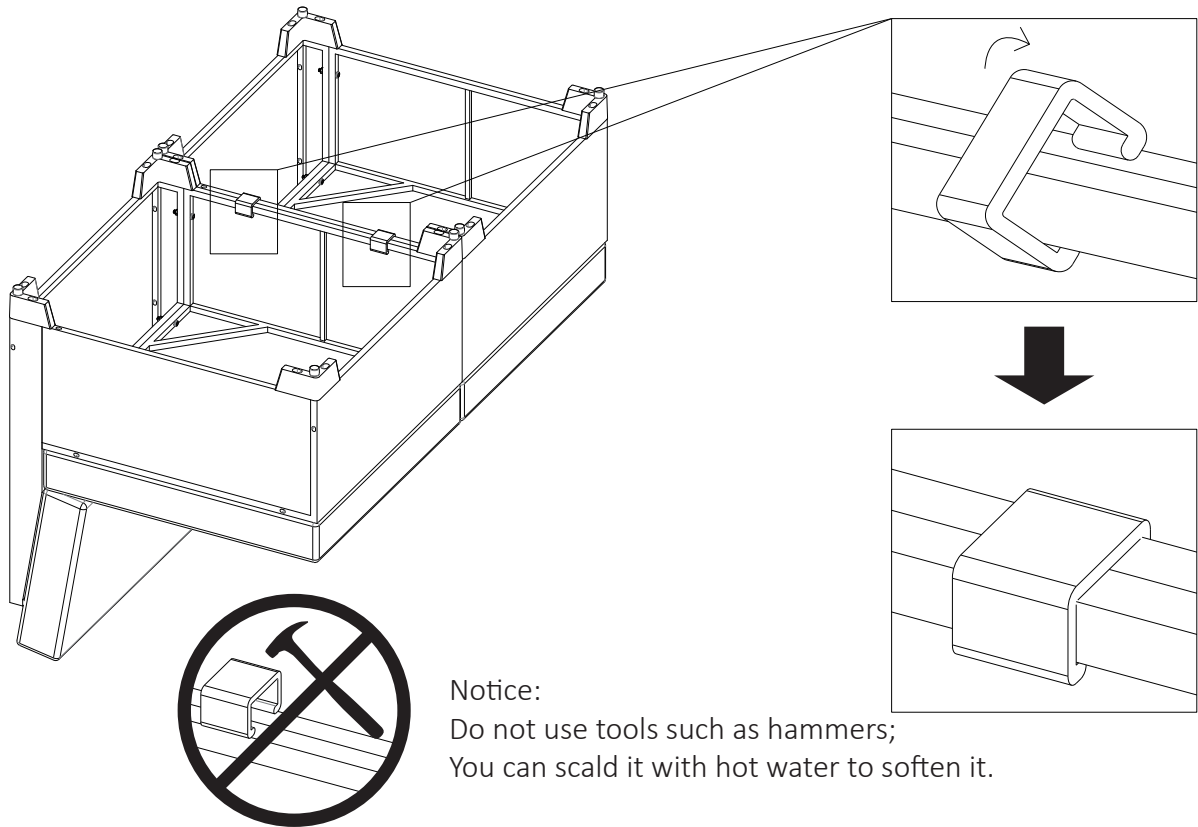

How to Assemble End Cap

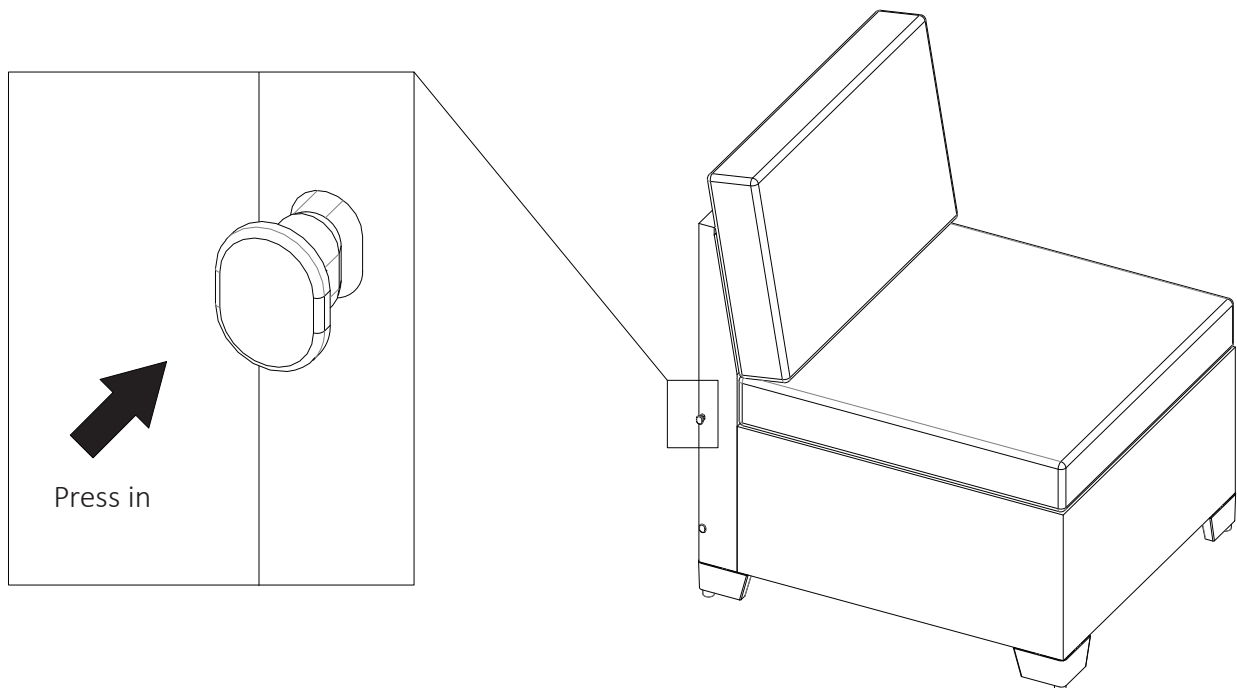

You can cover all the holes by press in the end caps.

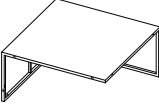
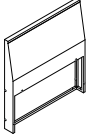
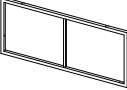
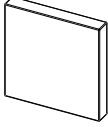
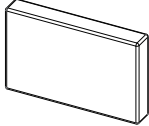
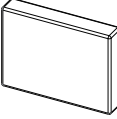
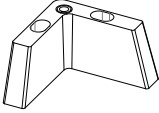
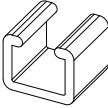

Packing List of Box A and C

Box	Img	Part Name	Label No.	Qty
Box A		6 Pcs Seat Part	6ST	4
		6 Pcs Back Part	6BK	3
		6 Pcs Side Part	6SD	2
		Seat Cushion Foam	SCF	3
		Long Back Cushion	LBC	2
		Short Back Cushion	SBC	1
		High L-Shaped Feet	O	12
		U-Shaped Connector	U	5
	-	Screw Set	SSA	1
Box C	-	Seat Cushion Cover	SCC	5
	-	Long Back Cushion Cover	LBCC	5
	-	Short Back Cushion Cover	SBCC	1

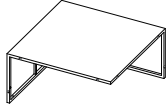
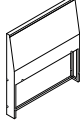
Packing List of Box B

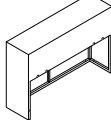
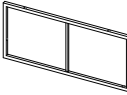
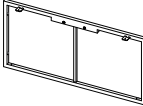
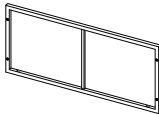
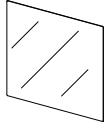
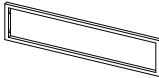
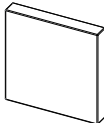
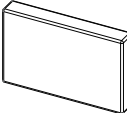
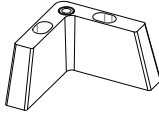
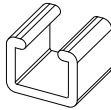
Box	Img	Part Name	Label No.	Qty
Box B		6 Pcs Seat Part	6ST	1
		6 Pcs Back Part	6BK	2
		6 Pcs Long Back Part	6LB	1
		6 Pcs Arm Part or 6 Pcs Arm Part With PSWOOD	6AM (6AM-P)	2
		6 Pcs Side Part	6SD	1
		Coffee Table Short Side Part	CTS	2
		Coffee Table Long Side Part	CTL	2
		Glass Top	GLS	1
		Coffee Table Connector	CTC	1
		Seat Cushion Foam	SCF	2
		Long Back Cushion	LBC	3
		High L-Shaped Feet	O	14
		U-Shaped Connector	U	5
-	Screw Set For Box B	SSB	1	

Packing List

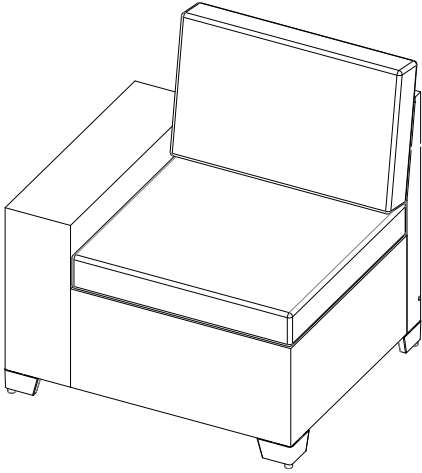

Right Arm Sofa x 1

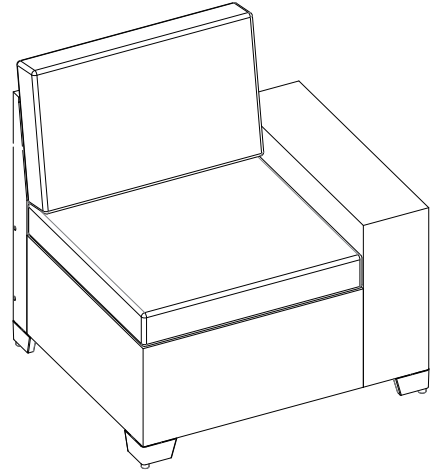

Left Arm Sofa x 1

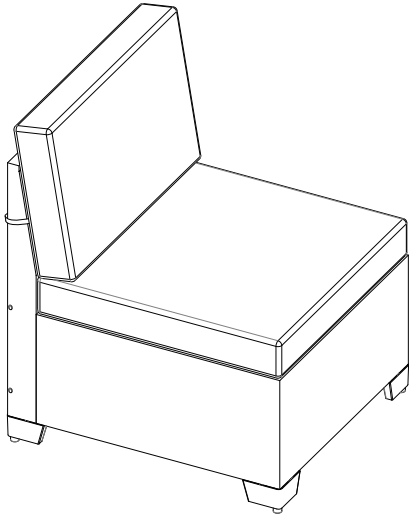

Armless Sofa x 2

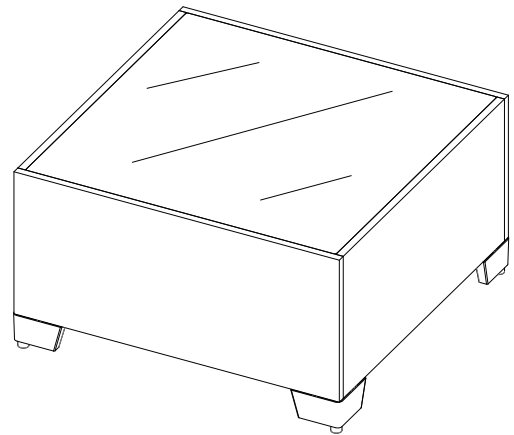

Coffee Table x 1

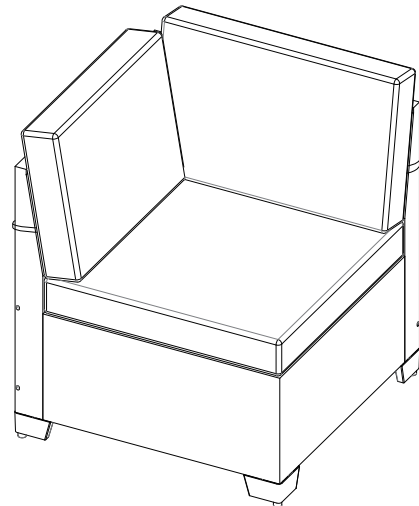
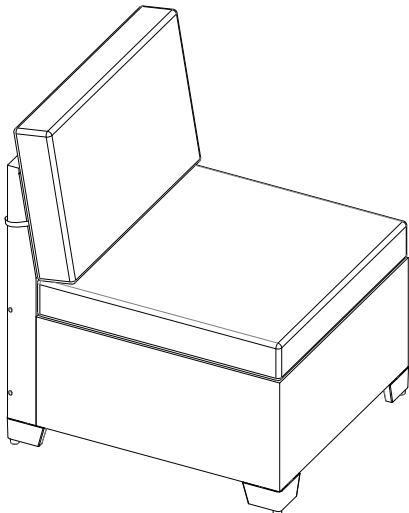

Armless Sofa or Corner Sofa x 1

Armless Sofa



Do not use machine Two Persons together Need 25mins roughly

Step 1: Assemble Back Part(6BK) And Seat Part(6ST).

Tips: Do not 100% Tight.

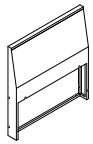
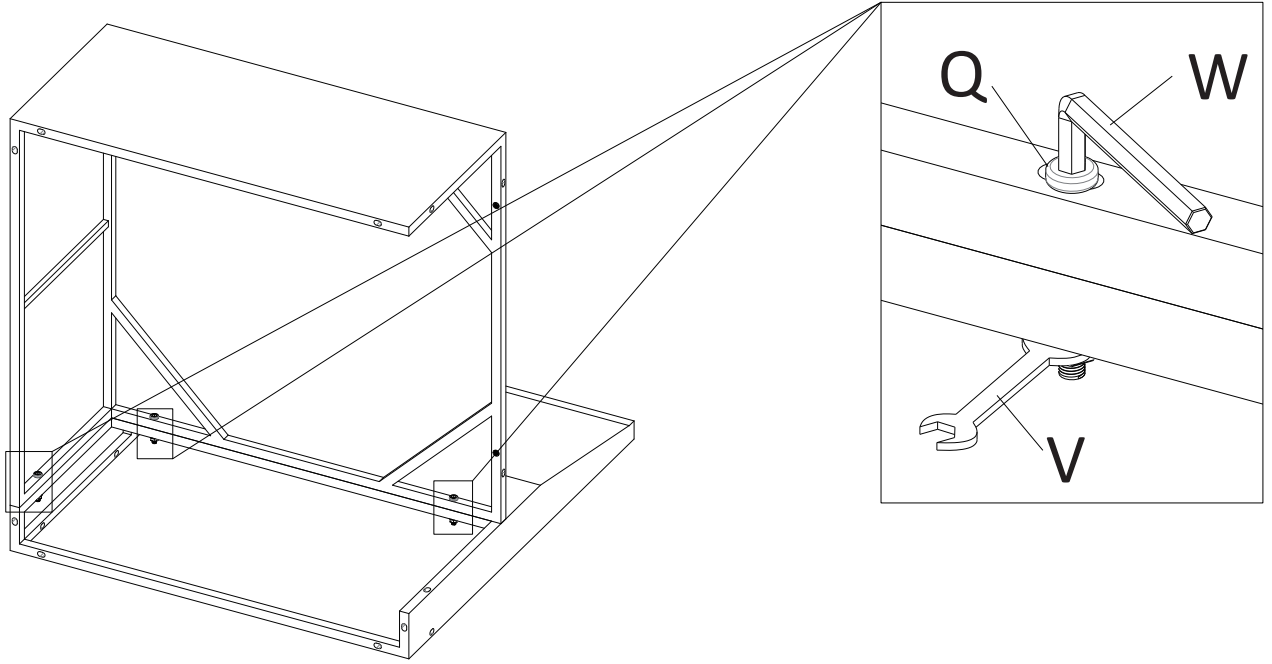

6BK x 1

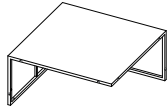

6ST x 1



M6x45(Q) x 3



Wrench(V) x 1



Spanner(W) x 1

Step 2: Assemble Side Part(6SD).

Tips: Screws 100% Tight This Step.

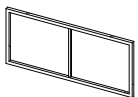
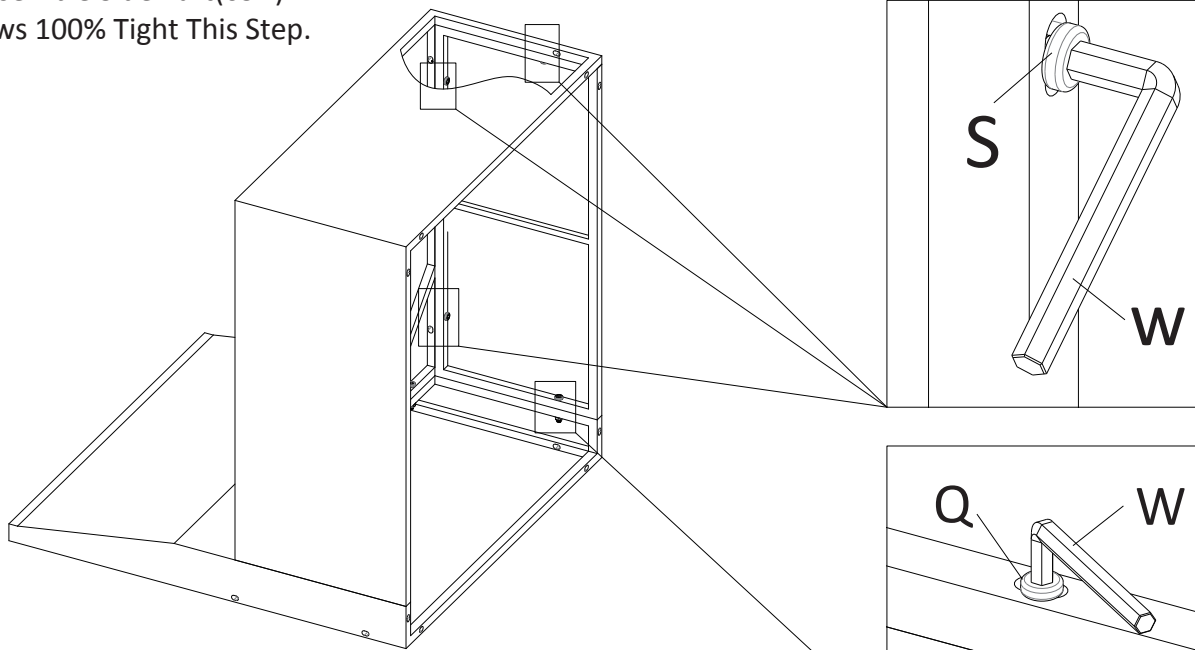

6SD x 1



M6x45(Q) x 1



M6x30(S) x 3



Wrench(V) x 1



Spanner(W) x 1

Armless Sofa



Do not use machine



Two Persons together



Need 25mins roughly

Step 3: Assemble High L-Shaped Feet And Screw Feet.

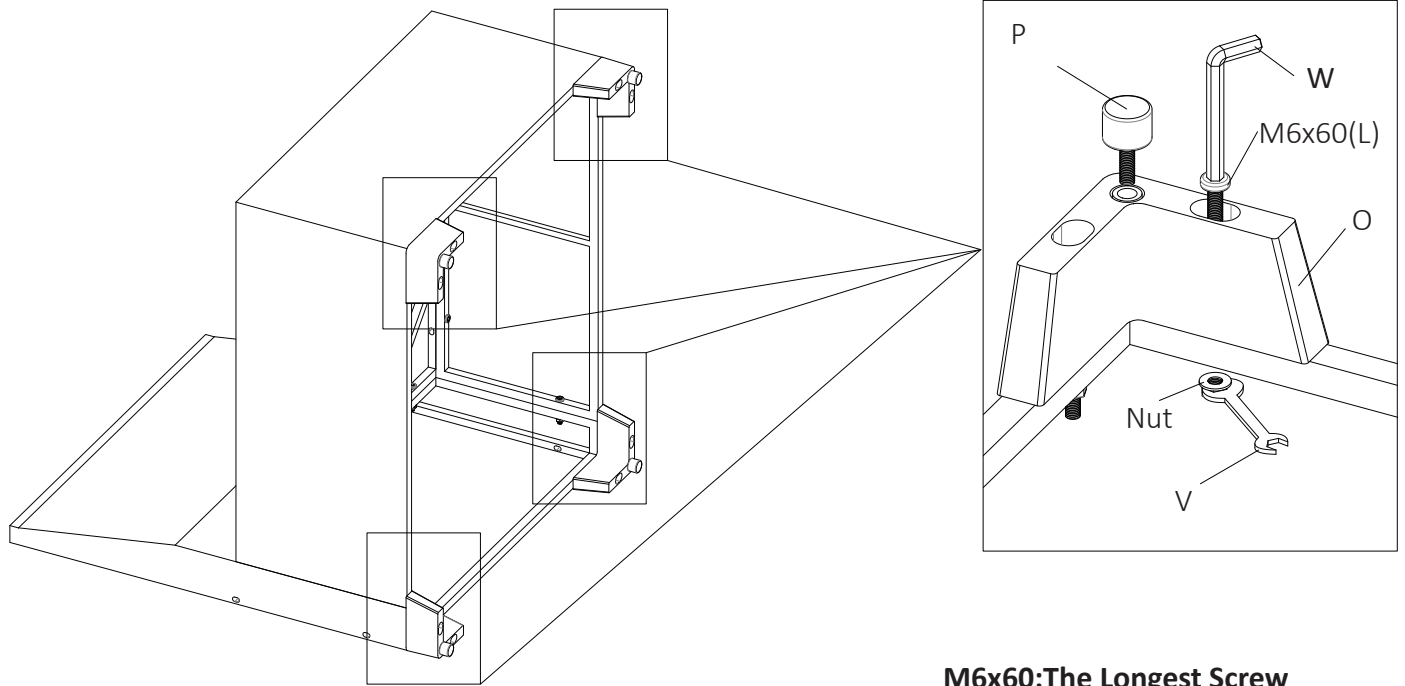

M6x60: The Longest Screw

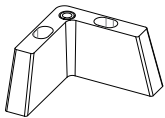

High L-Shaped Feet x 4

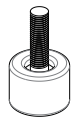

Screw Feet(P) x 4



M6x60 x 8



Wrench(V) x 1



Spanner(W) x 1

Step 4: Put the Seat Cushion and Back Cushion on.

Tips: The cushions can be fixed on the back of the sofa with ties. If you don't need the ties, you can cut them off.

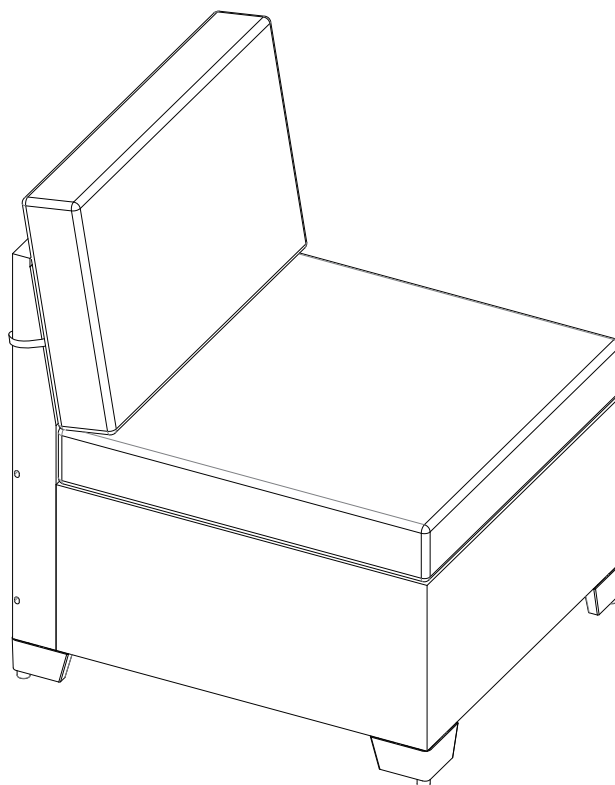

Left Arm Sofa



Do not use machine Two Persons together Need 25mins roughly

Step 1: Assemble Back Part(6BK) And Seat Part(6ST).

Tips: Do not 100% Tight.

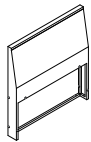
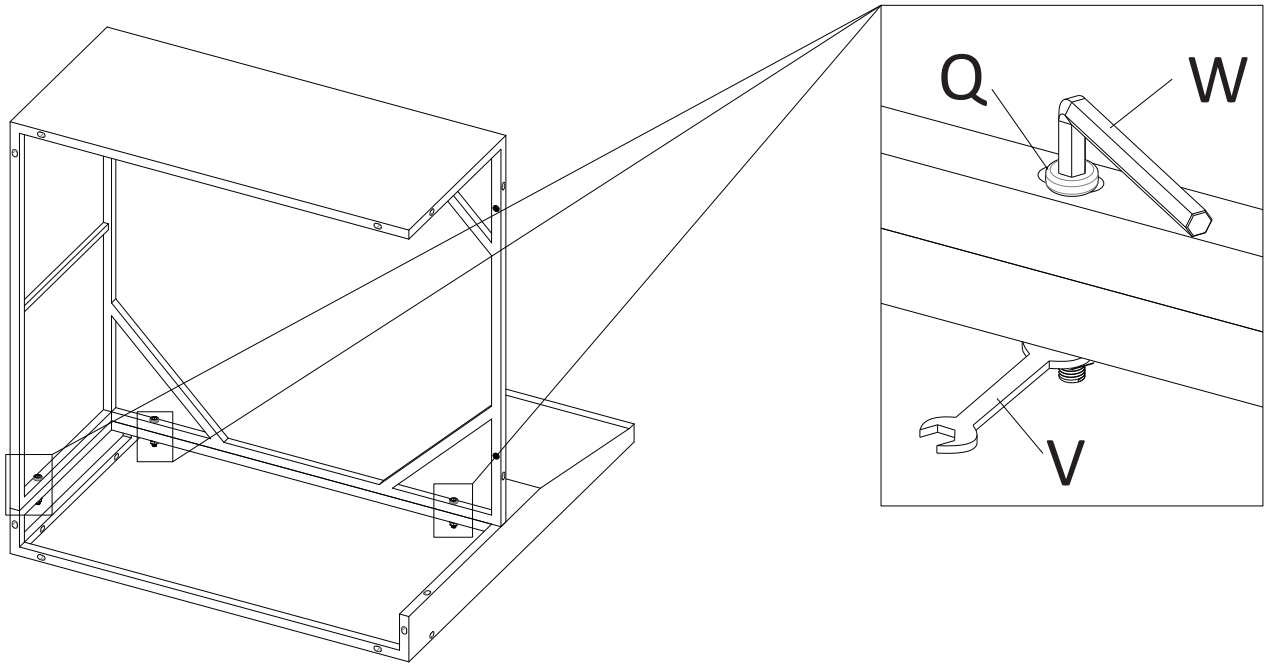

6BK x 1

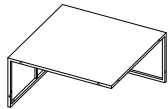

6ST x 1



M6x45(Q) x 3



Wrench(V) x 1



Spanner(W) x 1

Step 2: Assemble Arm Part(6AM) or Arm Part with PSWOOD(6AM-P).

Tips: Screws 100% Tight This Step.

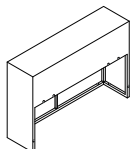
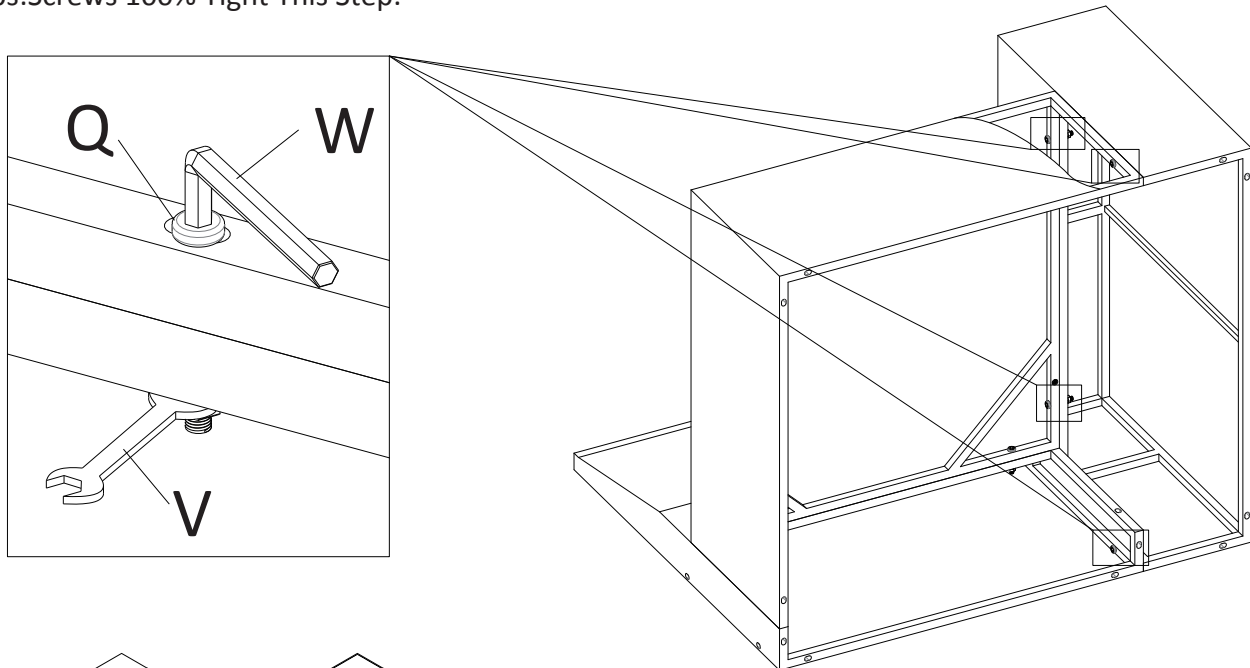

6AM x 1

Or

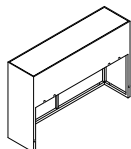

6AM-P x 1



M6x45(Q) x 4



Wrench(V) x 1



Spanner(W) x 1

Left Arm Sofa



Do not use machine



Two Persons together



Need 25mins roughly

Step 3: Assemble High L-Shaped Feet.

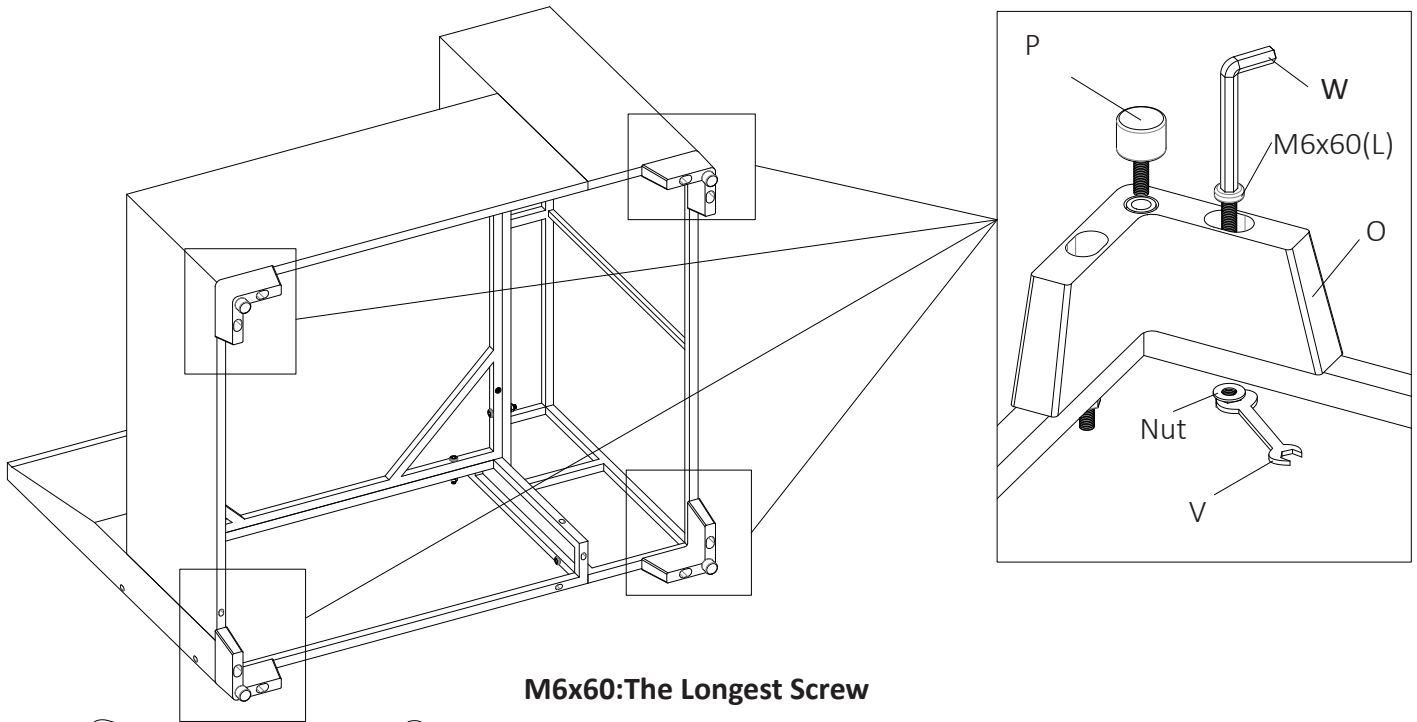

M6x60: The Longest Screw

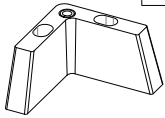

High L-Shaped Feet x 4

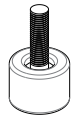

Screw Feet(P) x 4



M6x60 x 8



Wrench(V) x 1



Spanner(W) x 1

Step 4: Put the Seat Cushion and Back Cushion on.

Tips: The cushions can be fixed on the back of the sofa with ties. If you don't need the ties, you can cut them off.

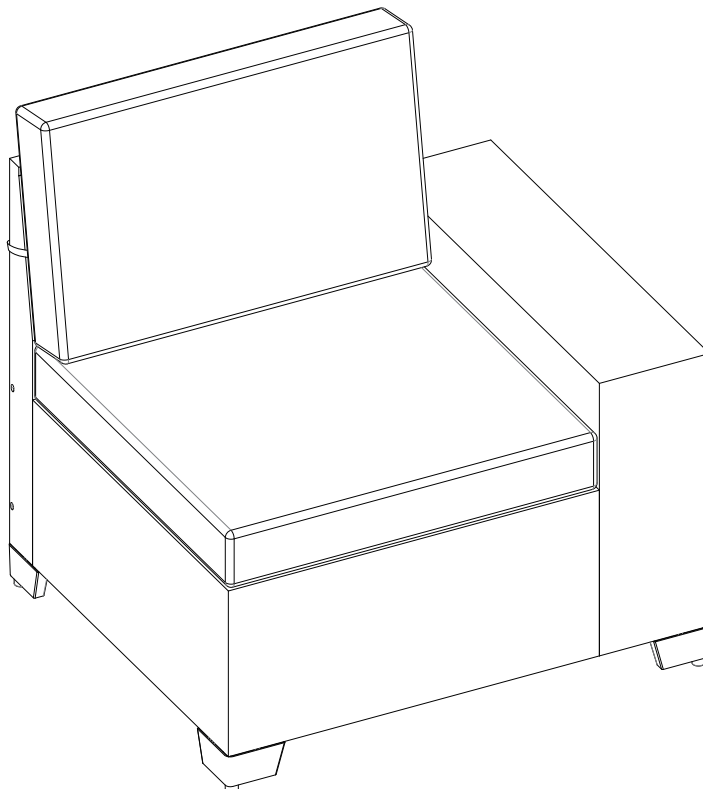

Right Arm Sofa



Do not use machine



Two Persons together



Need 25mins roughly

Step 1: Assemble Back Part(6BK) And Seat Part(6ST).

Tips: Do not 100% Tight.

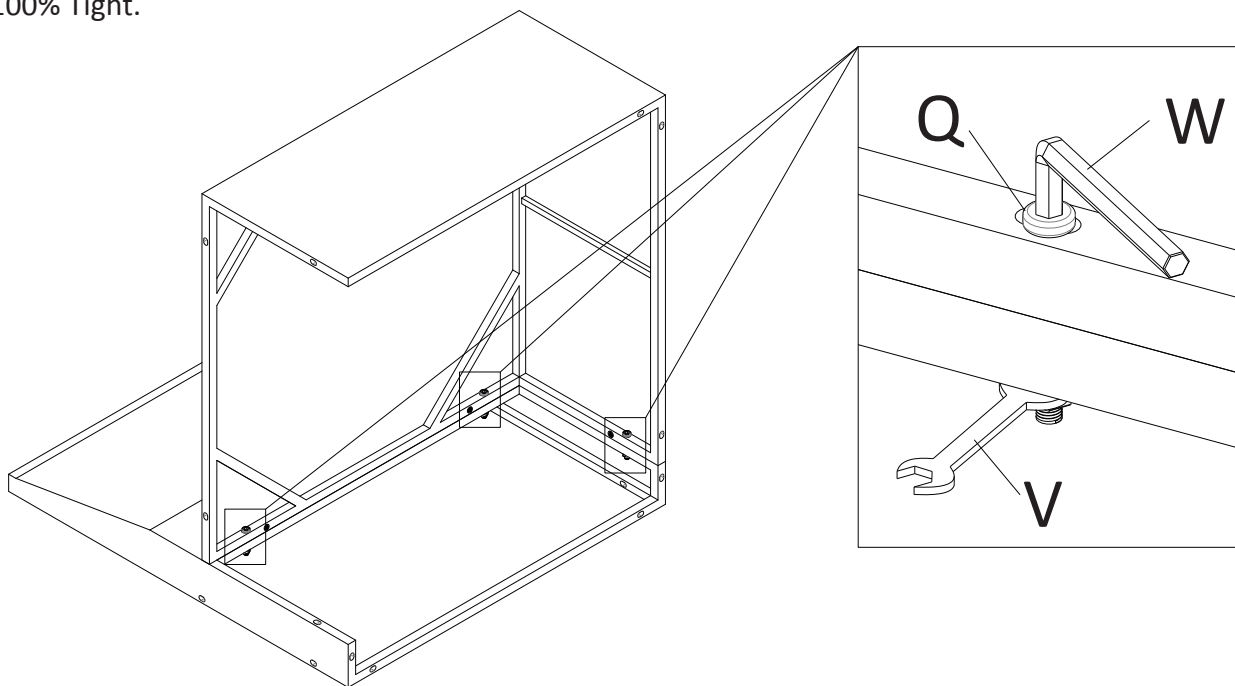

6BK x 1

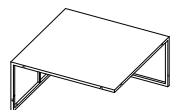

6ST x 1



M6x45(Q) x 3



Wrench(V) x 1



Spanner(W) x 1

Step 2: Assemble Arm Part(6AM) or Arm Part with PSWOOD(6AM-P).

Tips: Screws 100% Tight This Step.

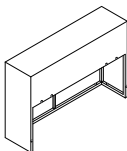
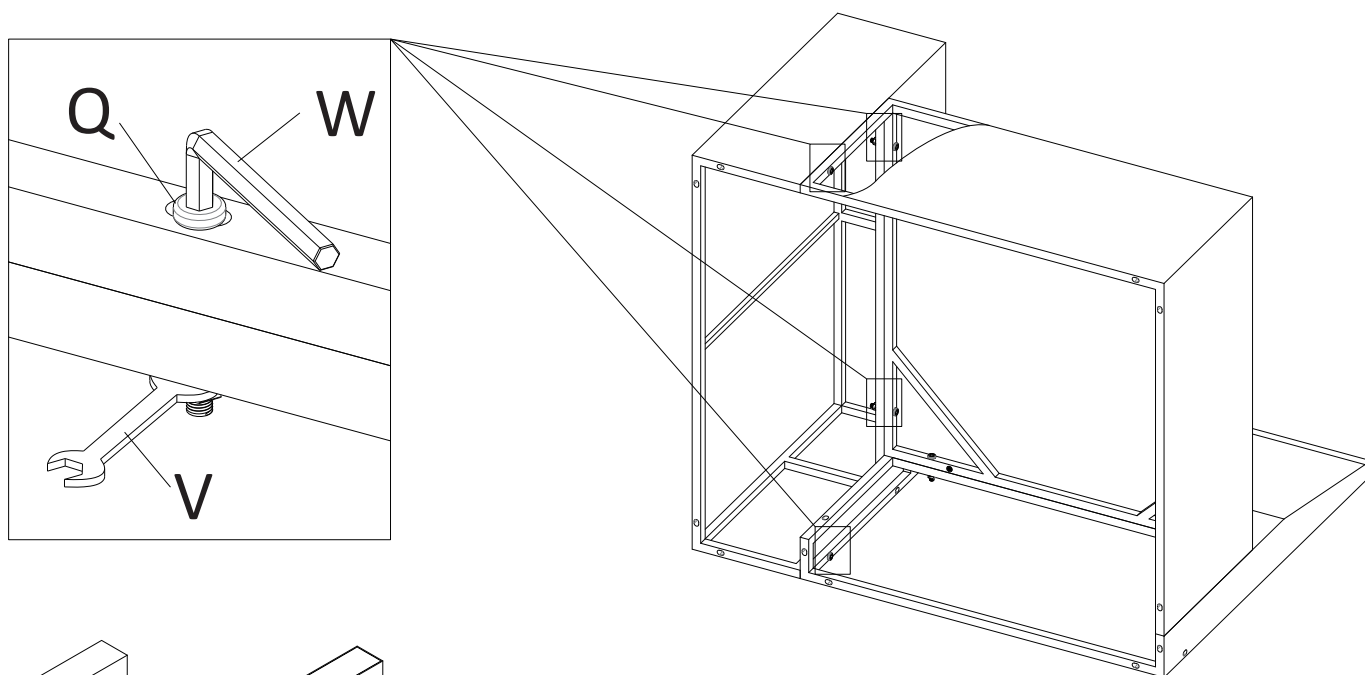

6AM x 1

Or

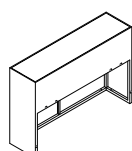

6AM-P x 1



M6x45(Q) x 4



Wrench(V) x 1



Spanner(W) x 1

Right Arm Sofa



Do not use machine



Two Persons together



Need 25mins roughly

Step 3: Assemble High L-Shaped Feet.

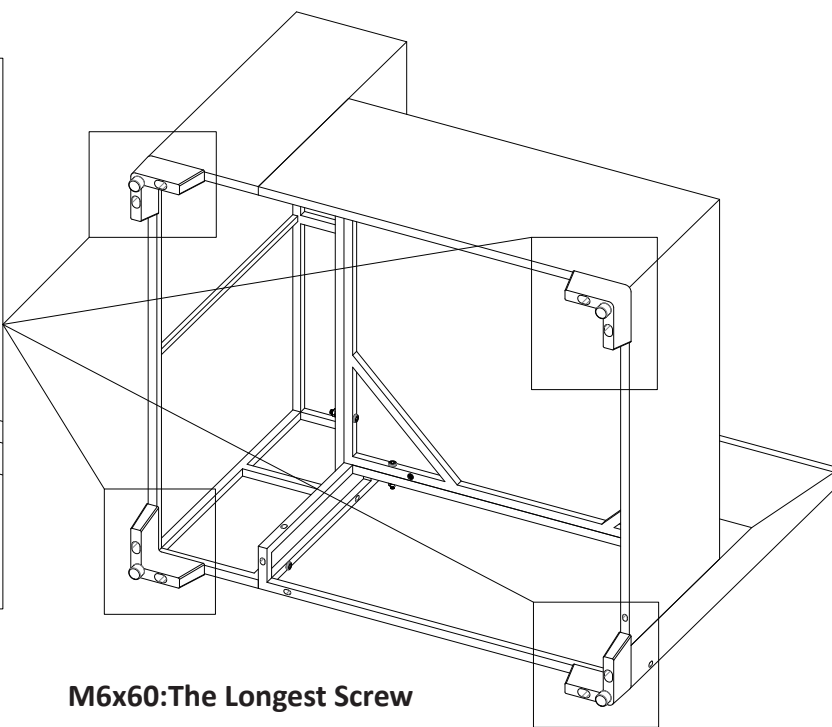
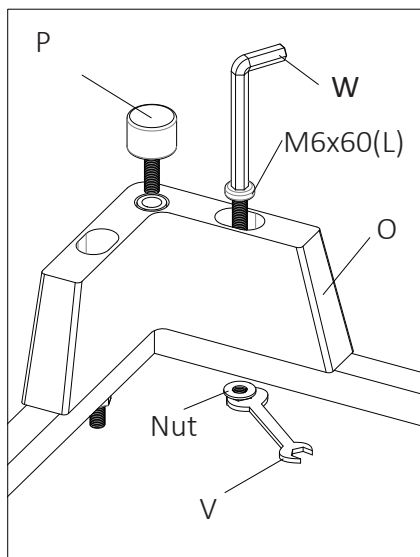

M6x60: The Longest Screw

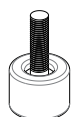
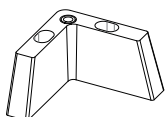

High L-Shaped Feet x 4

Screw Feet(P) x 4

M6x60 x 8

Wrench(V) x 1

Spanner(W) x 1

Step 4: Put the Seat Cushion and Back Cushion on.

Tips: The cushions can be fixed on the back of the sofa with ties. If you don't need the ties, you can cut them off.

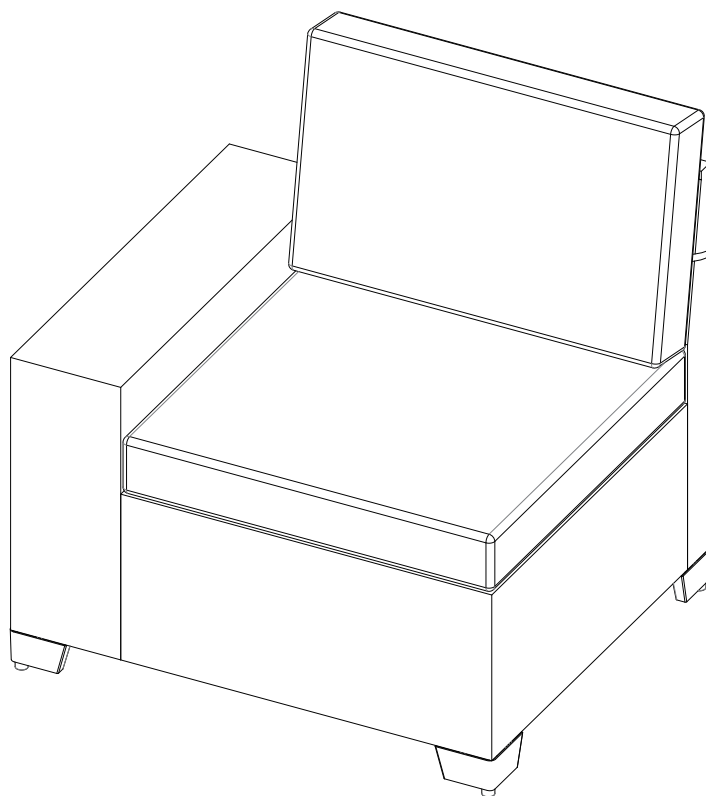

Corner Sofa



Do not use machine



Two Persons together



Need 25mins roughly

Step 1: Assemble Back Part(6BK) And Seat Part(6ST).

Tips: Do not 100% Tight.

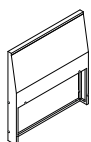
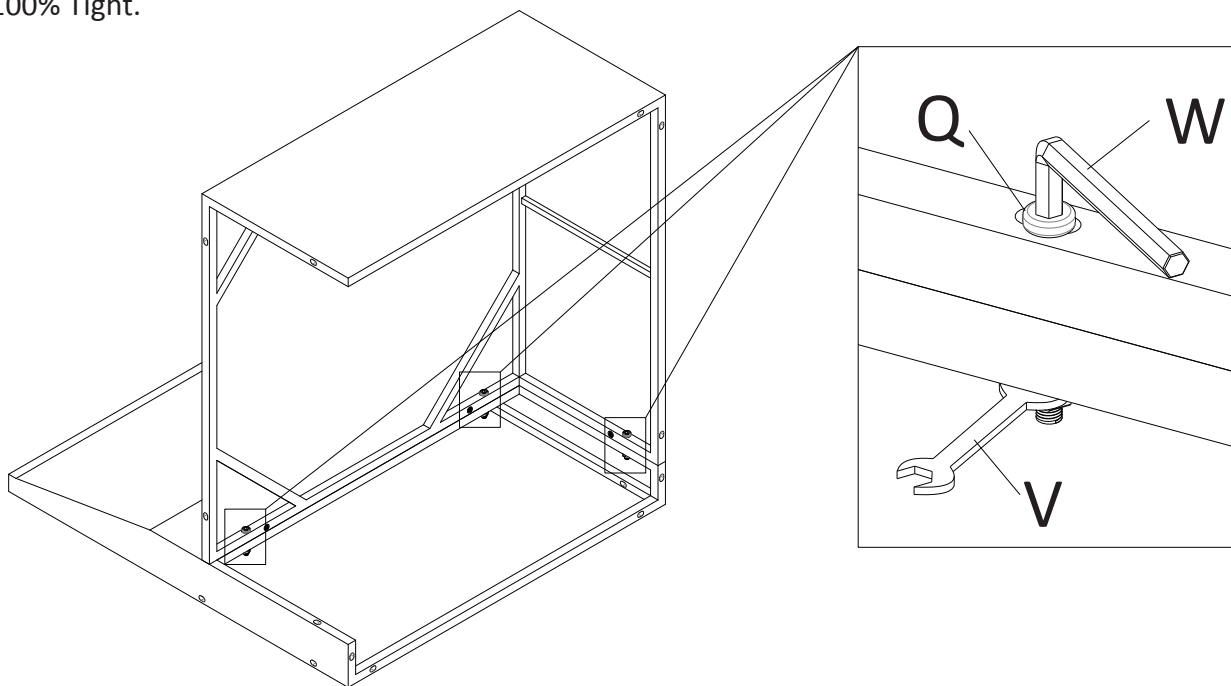

6BK x 1

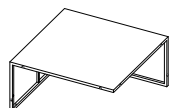

6ST x 1



M6x45(Q) x 3



Wrench(V) x 1



Spanner(W) x 1

Step 2: Assemble Long Back Part(6LB).

Tips: Screws 100% Tight This Step.

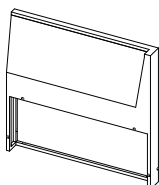
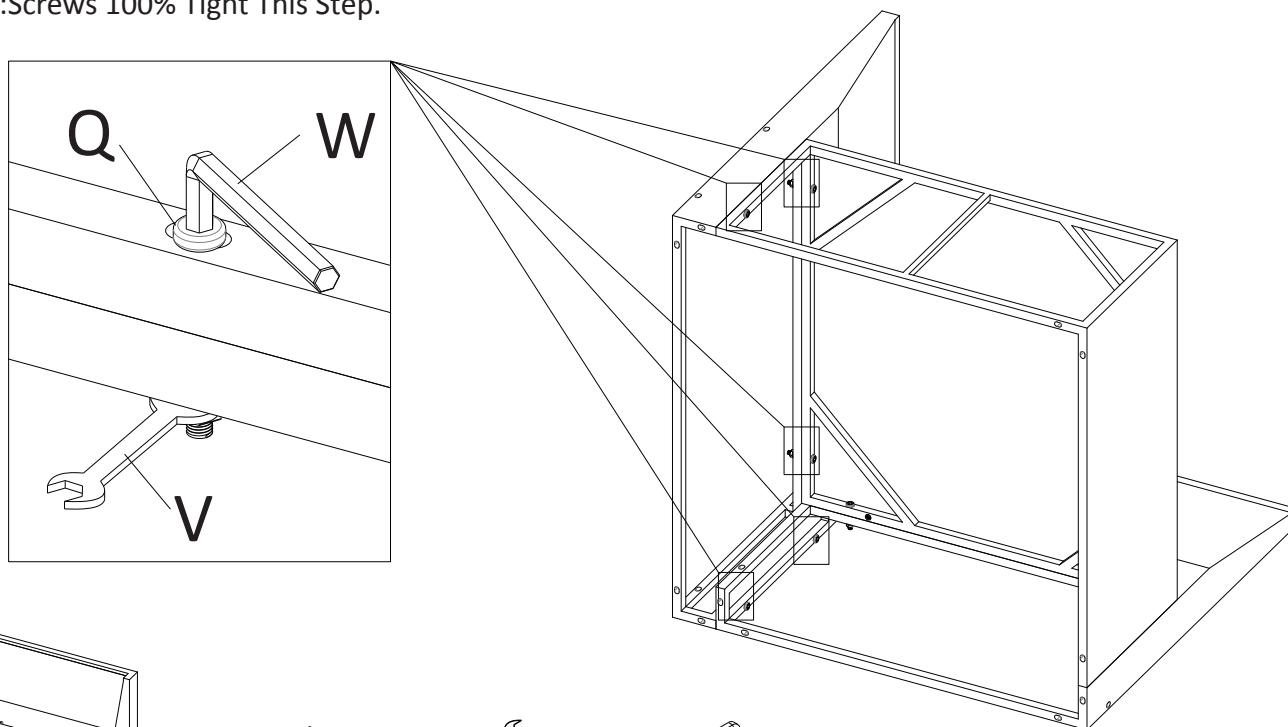

6LB x 1



M6x45(Q) x 5



Wrench(V) x 1



Spanner(W) x 1

Corner Sofa



Do not use machine



Two Persons together



Need 25mins roughly

Step 3: Assemble High L-Shaped Feet.

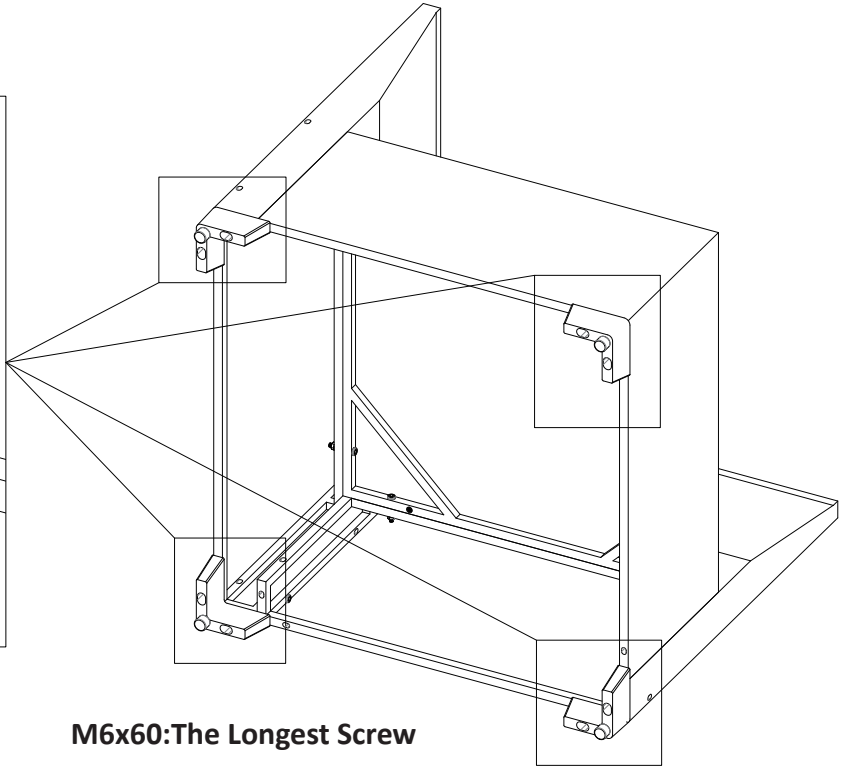
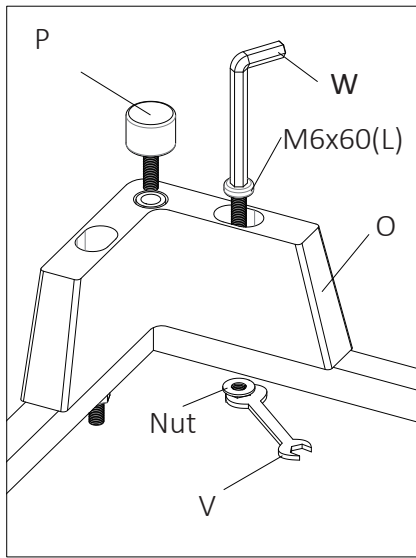

M6x60: The Longest Screw

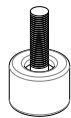
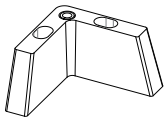

High L-Shaped Feet x 4

Screw Feet(P) x 4

M6x60 x 8

Wrench(V) x 1

Spanner(W) x 1

Step 4: Put the Seat Cushion, Short Back Cushion and Long Back Cushion on.

Tips: The cushions can be fixed on the back of the sofa with ties. If you don't need the ties, you can cut them off.

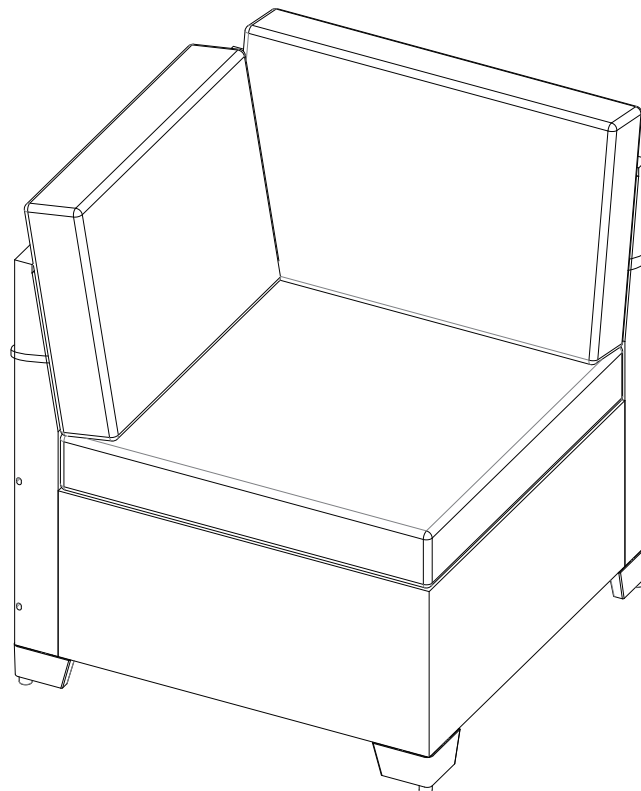

Coffee Table



Do not use machine



Two Persons together



Need 25mins roughly

Step 1: Assemble CTL and CTS.

Tips: Do not 100% tight.

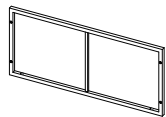
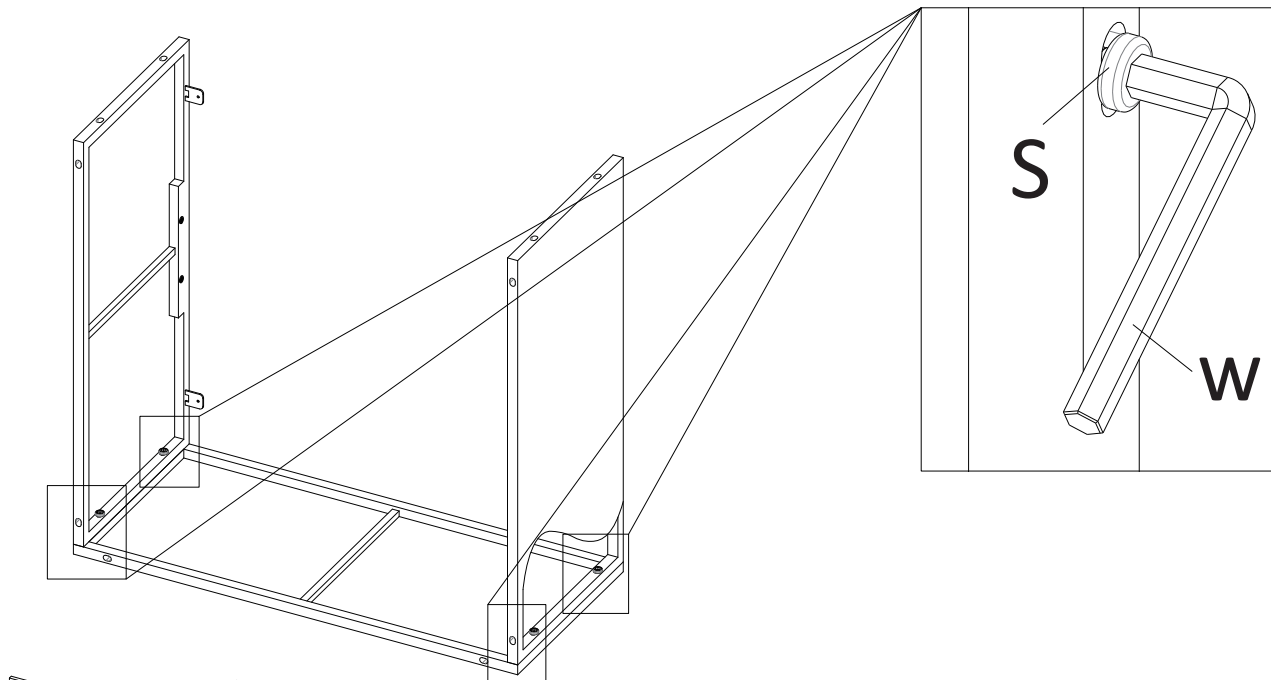

CTL x 1

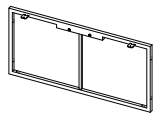

CTS x 2



M6x30(S) x 4



Spanner(W) x 1

Step 2: Assemble CTC

Tips: Do not 100% tight.

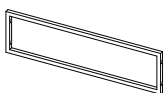
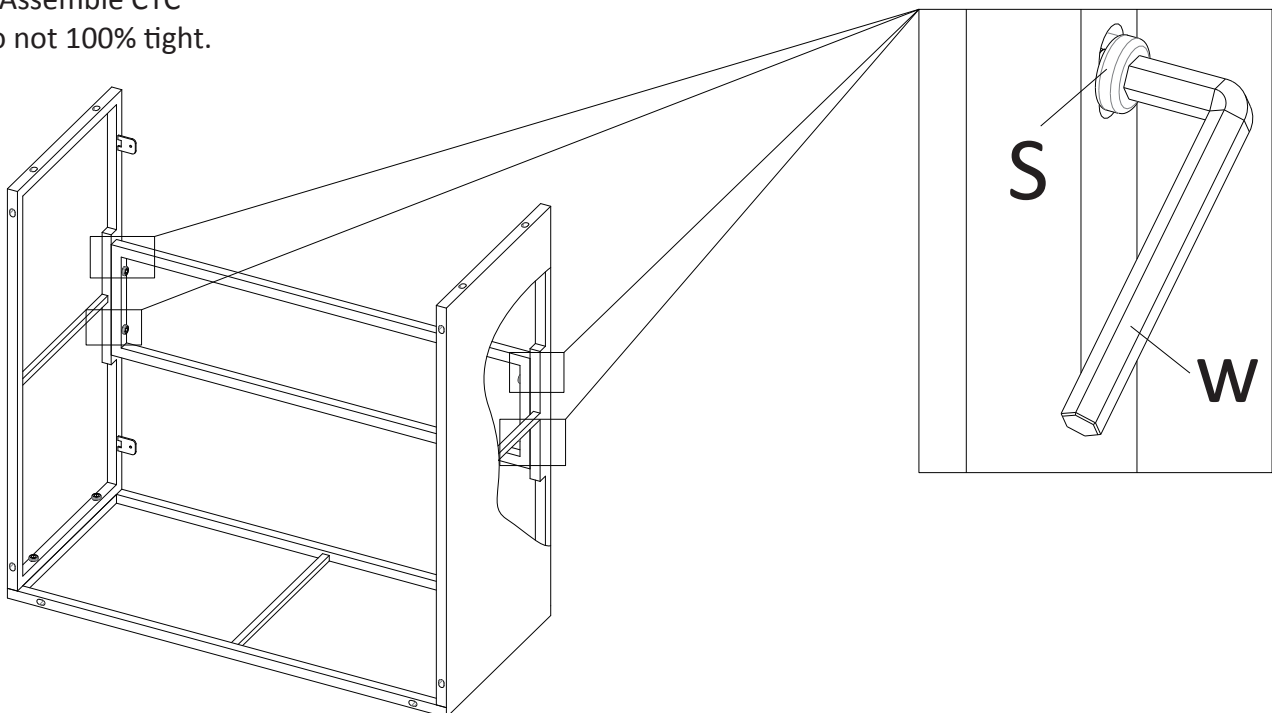

CTC x 1



M6x30(S) x 4

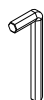

Spanner(W) x 1

Coffee Table



Do not use machine



Two Persons together



Need 25mins roughly

Step 3: Assemble CTL.

Tips: Screws 100% Tight This Step.

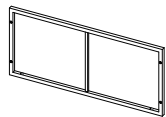
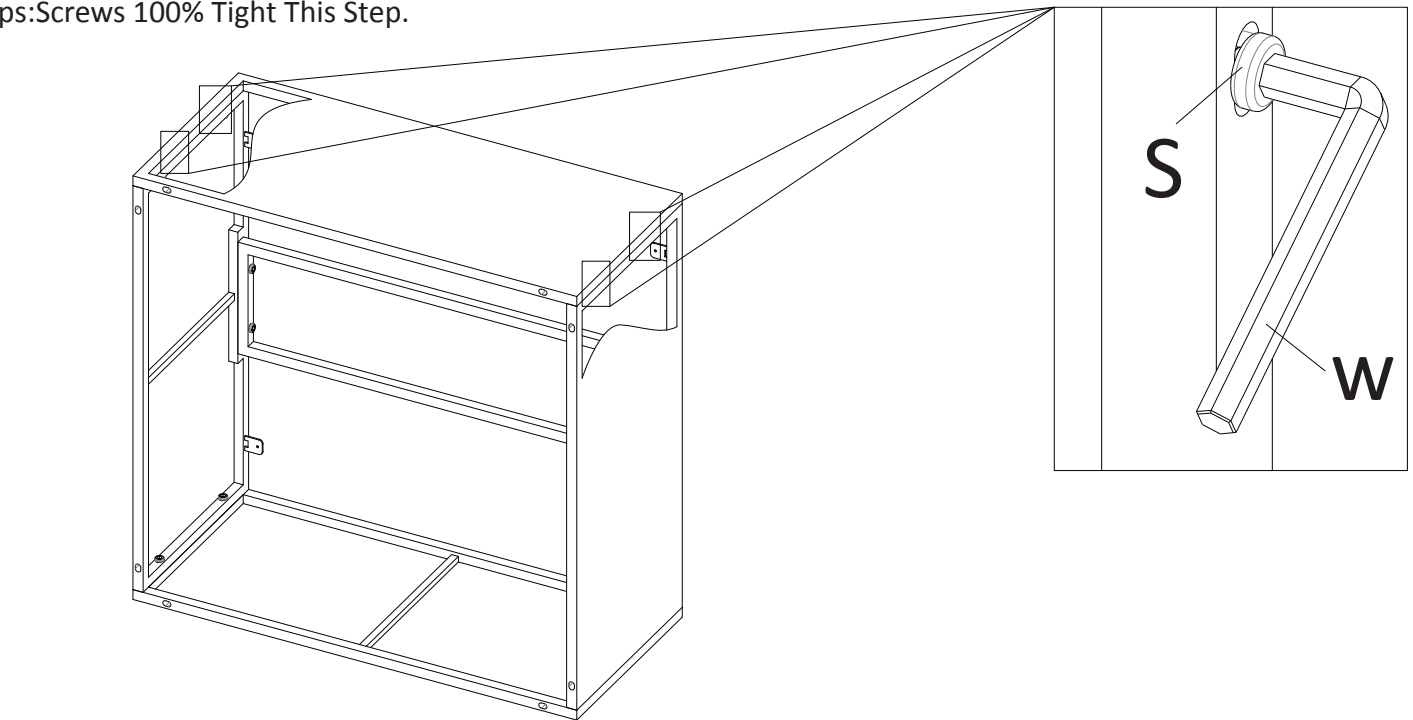

CTL x 1



M6x30(S) x 4



Spanner(W) x 1

Step 4: Assemble High L-Shaped Feet.

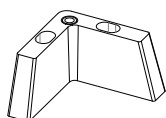
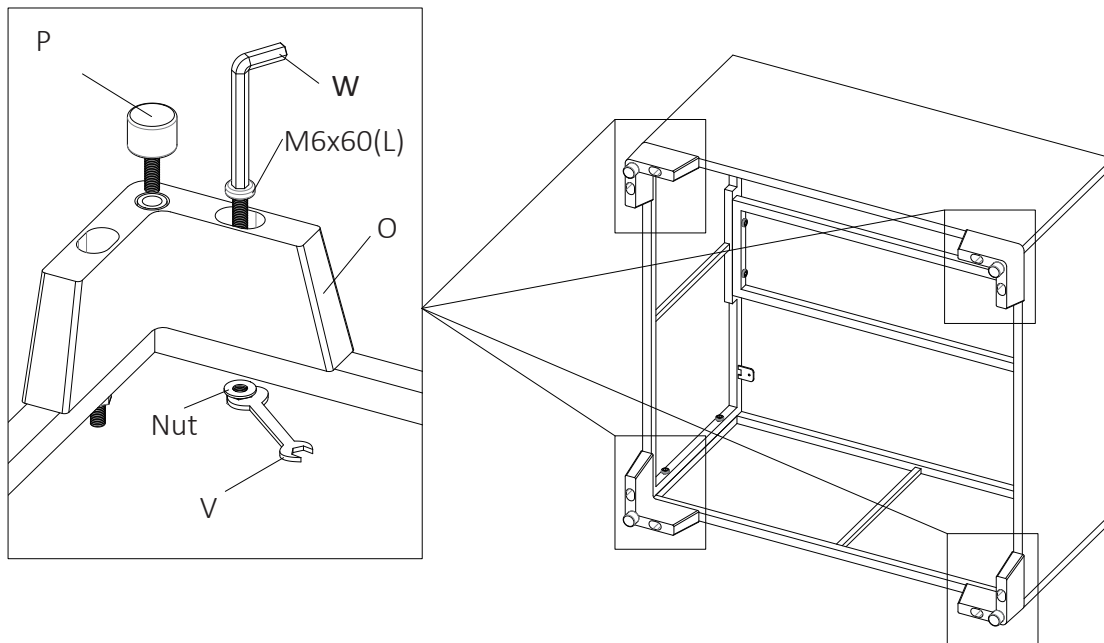

High L-Shaped Feet x 4

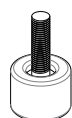

Screw Feet(P) x 4



M6x60 x 8



Wrench(V) x 1



Spanner(W) x 1

Coffee Table



Do not use machine



Two Persons together



Need 25mins roughly

Step 5: Press in the Glass Pads.

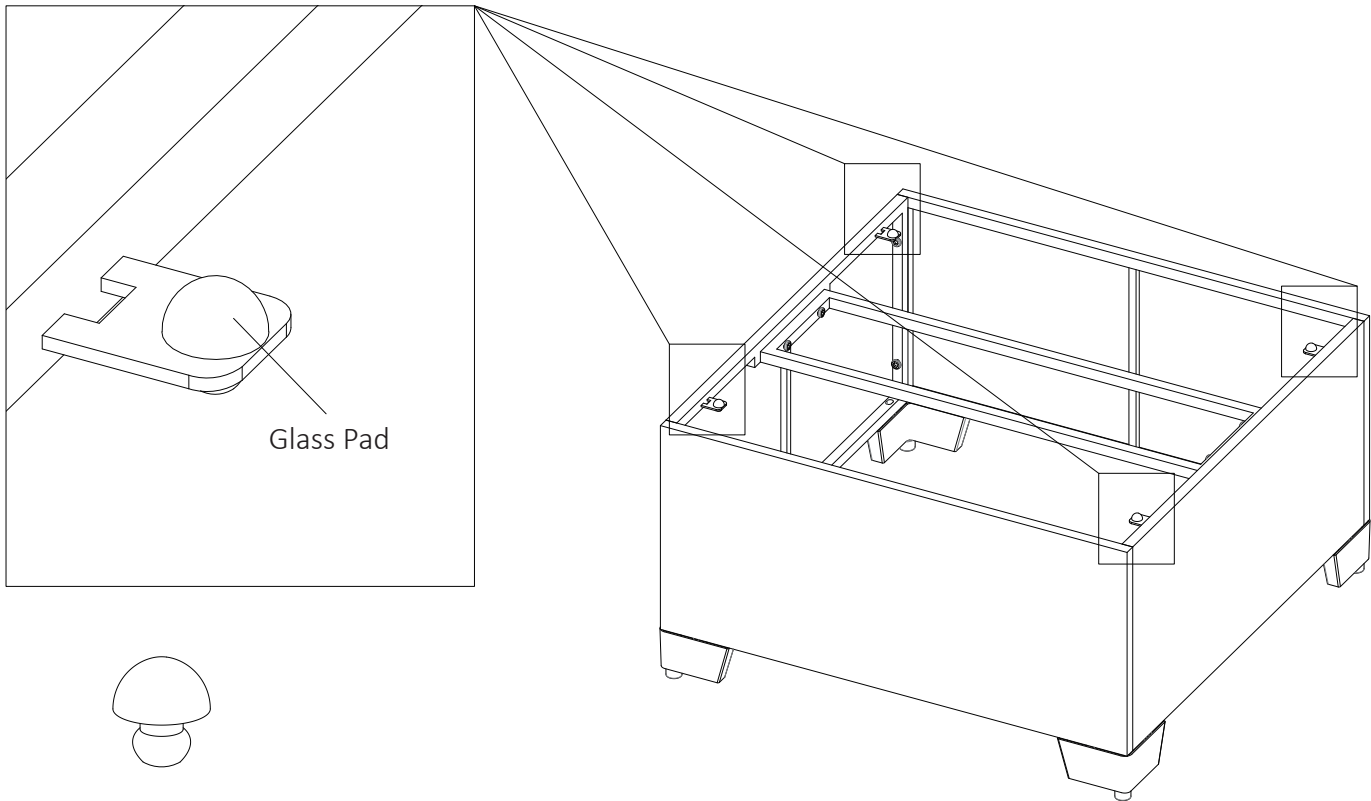

Glass Pad

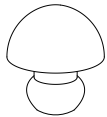

Glass Pad x 4

Step 6: Put on the Glass Top

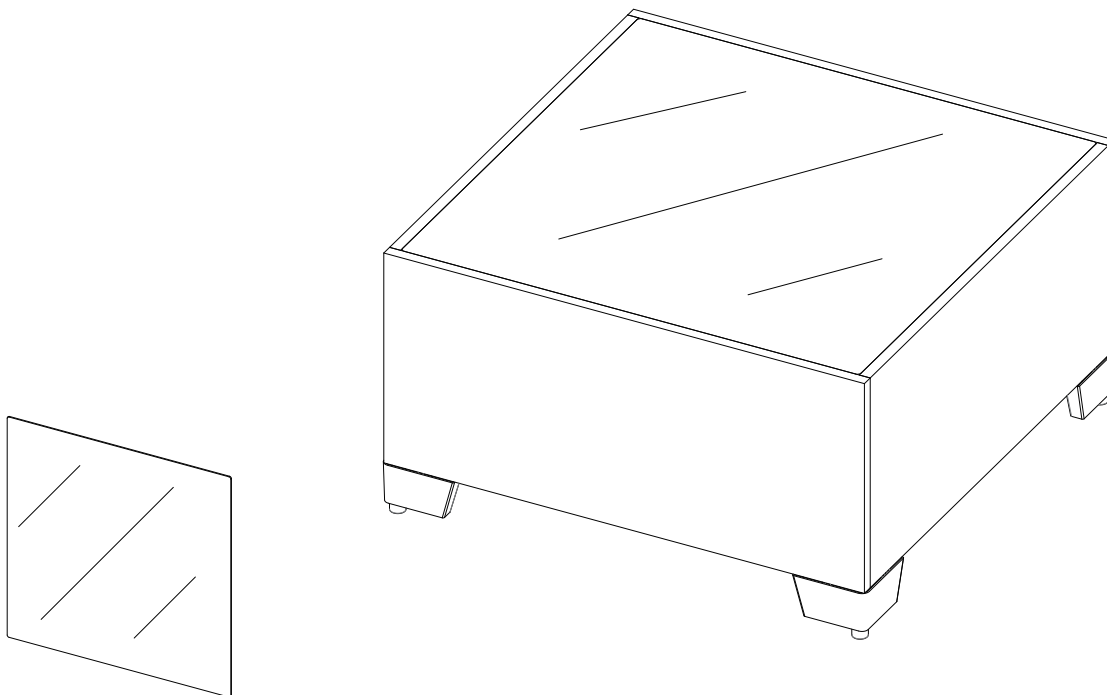

Glass Top x 1

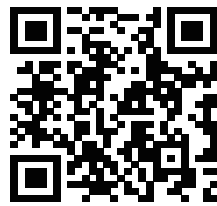

www.alaulm.com

Make your life much better.