









# ASSEMBLY INSTRUCTIONS

WF299348AAD PREVE CHAIRS

Read this instruction carefully. Refer hardware and furniture parts list for guidance. Be sure all parts are complete, before assembling. Place all wooden furniture part on a clean and flat soft surface to prevent scratcheds. Refer steps provided as assembling guide.

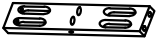
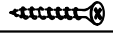
**CAUTIONS :**

1. Do not **FULLY-TIGHTEN** the nuts or nut bolts until all are in place.
2. To prevent thread damage. Ensure that nuts or nut bolts are not over-tighten.
3. Hardware are to be kept out of reach from children.

PART LIST				HARDWARE LIST		
ITEM	DESCRIPTION	QTY	ITEM	DESCRIPTION	QTY	
1	CHAIR BACK 	1 PC	A	JCBC SCREW M6 x 50MM 	8 PCS	
2	FRONT LEG 	1 PC	B	SPRING WASHER 	8 PCS	
3	SIDE RAIL ( L & R ) 	2 PCS	C	CSK SCREW M4 x 32MM 	4 PCS	
4	CUSHION SEAT 	1 PC	D	WOOD DOWEL 	2 PCS	
			E	ALLEN KEY M4 	1 PC	

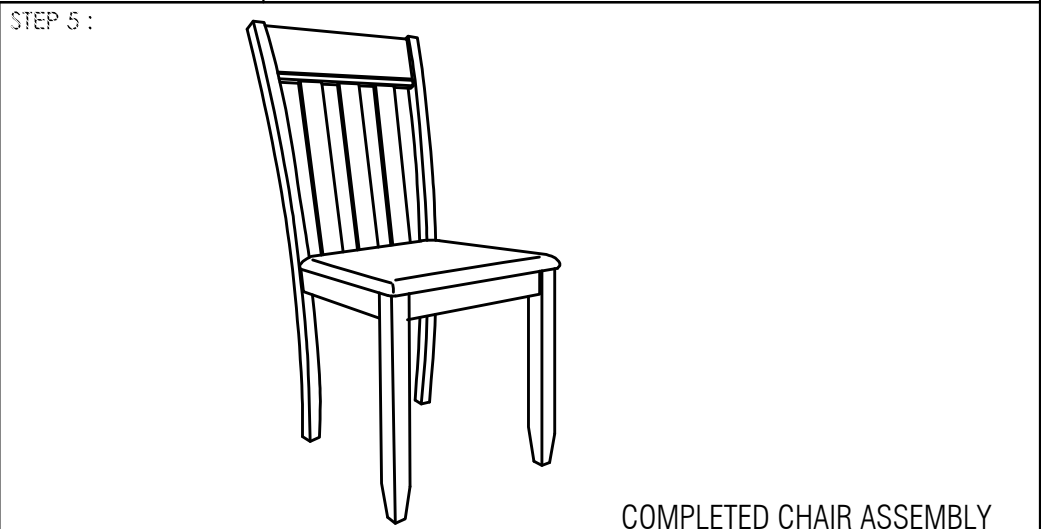
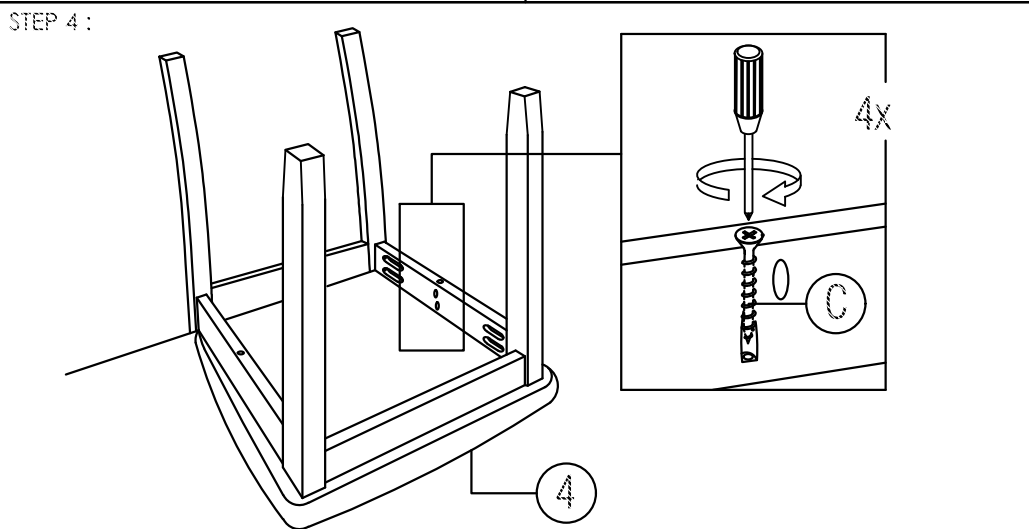
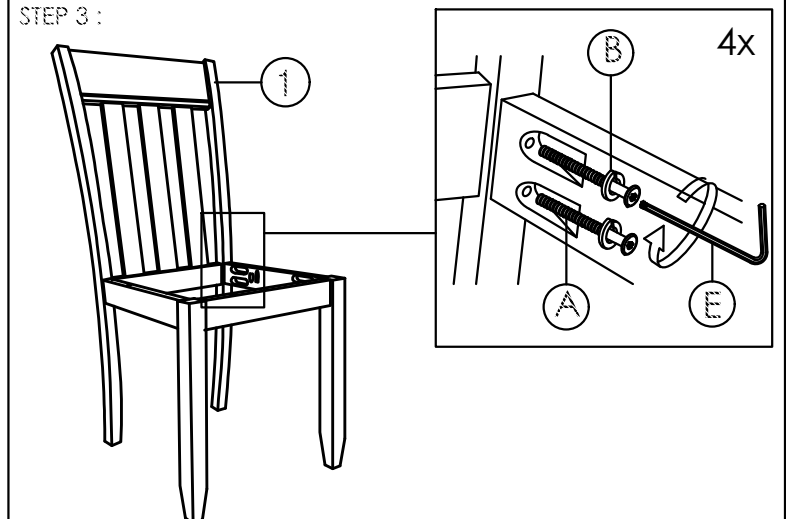
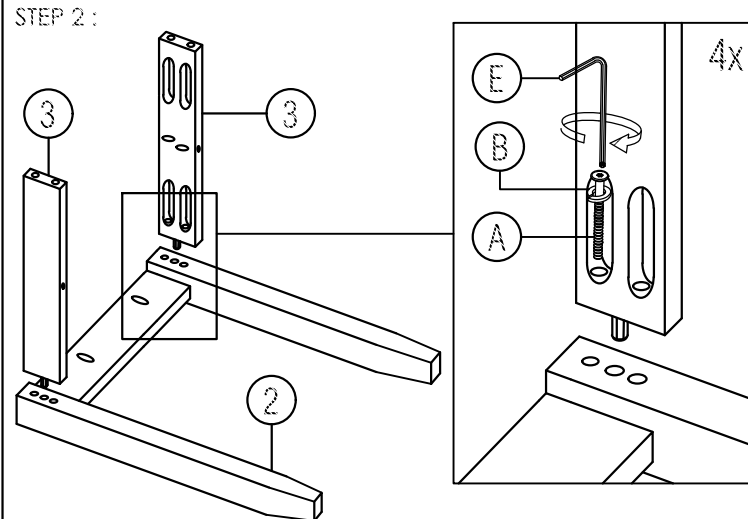
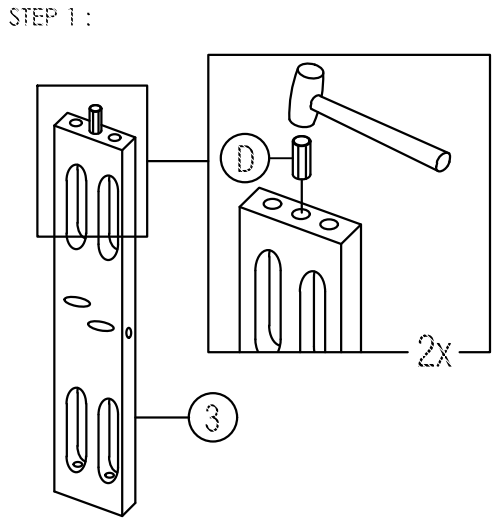

# ASSEMBLY INSTRUCTIONS

WF299347AAD PREVE TABLE

Read this instruction carefully. Refer hardware and furniture parts list for guidance. Be sure all parts are complete, before assembling. Place all wooden furniture part on a clean and flat soft surface to prevent scratches. Refer steps provided as assembling guide.

PART LIST				HARDWARE LIST		
ITEM	DESCRIPTION	QTY	ITEM	DESCRIPTION	QTY	
1	TABLE TOP	1 PC	A	JCBC SCREW M6 x 40MM	30 PCS	
2	TABLE LEG - L & R	4 PCS	B	SPRING WASHER 13MM	30 PCS	
3	CENTER STRETCHER RAIL	1 PC	C	FLAT WASHER 13MM	30 PCS	
4	LEG APRON SUPPORT	2 PCS	D	ALLEN KEY M4 ( SHORT )	1 PC	
5	MOULDING PLATE	2 PCS				

## CAUTIONS :

1. Do not **FULLY-TIGHTEN** the nuts or nut bolts until all are in place.
2. To prevent thread damage. Ensure that nuts or nut bolts are not over-tighten.
3. Hardware are to be kept out of reach from children.

### STEP 1

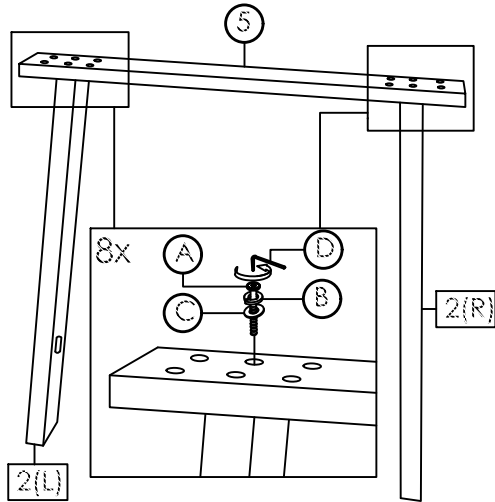

### STEP 2

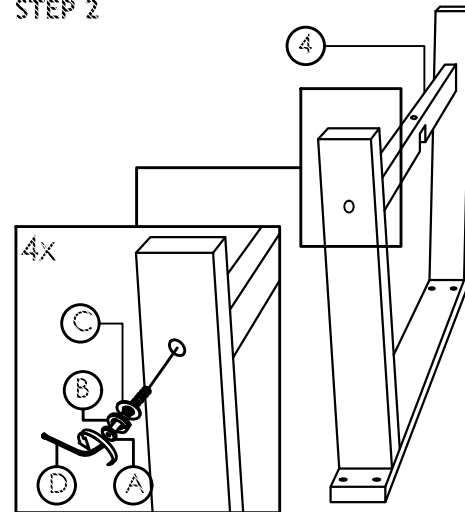

### STEP 4

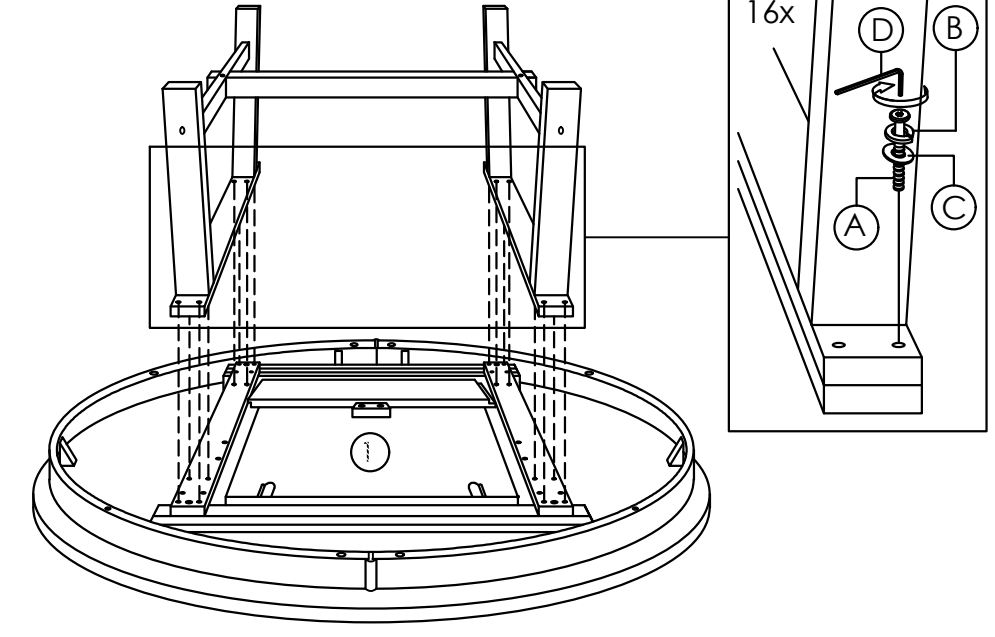

### STEP 3

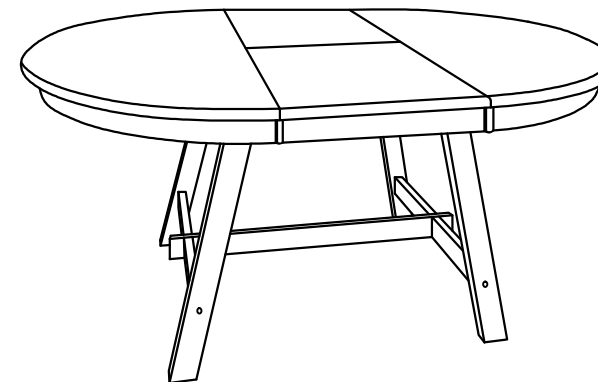
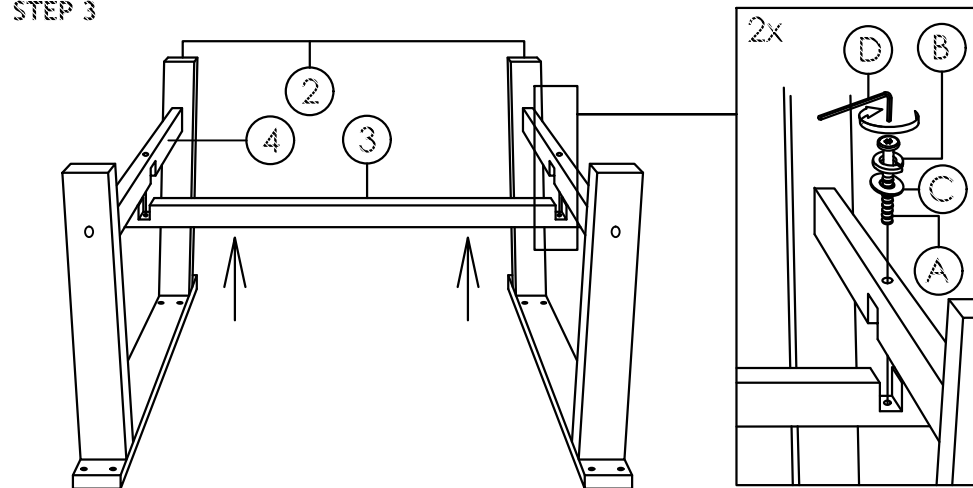

COMPLETED ASSEMBLY