

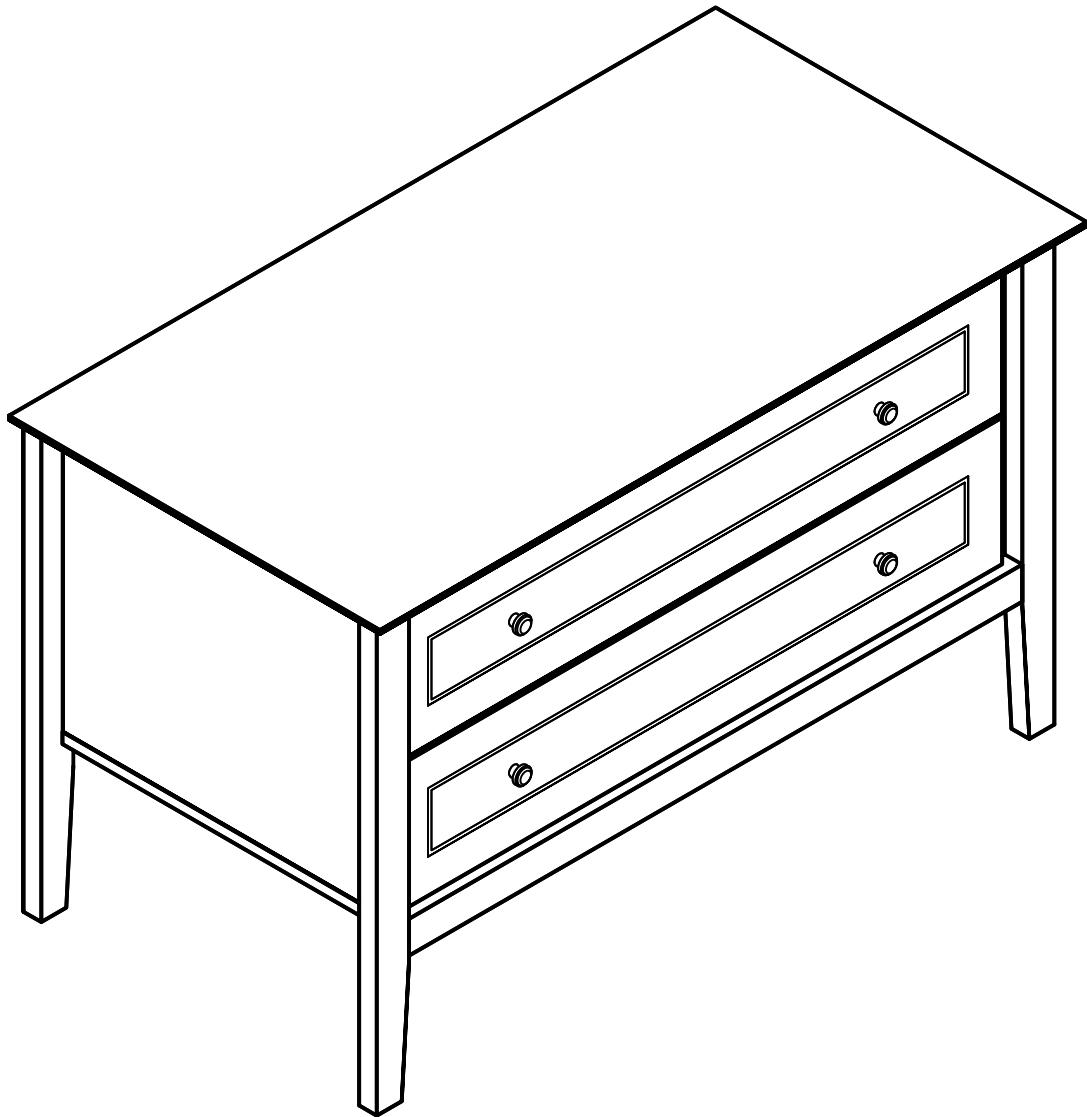

MANHATTAN  
COMFORT

---

# 205GMC



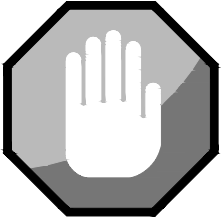

# STOP!

Before beginning the assembly process, ensure all boxes and parts have been delivered.

## FOR BEST RESULTS:

- Do not throw away packaging materials until assembly is complete.
- Assemble item on a soft surface, such as cardboard or carpet, to protect finish.
- Proper assembly requires two people.

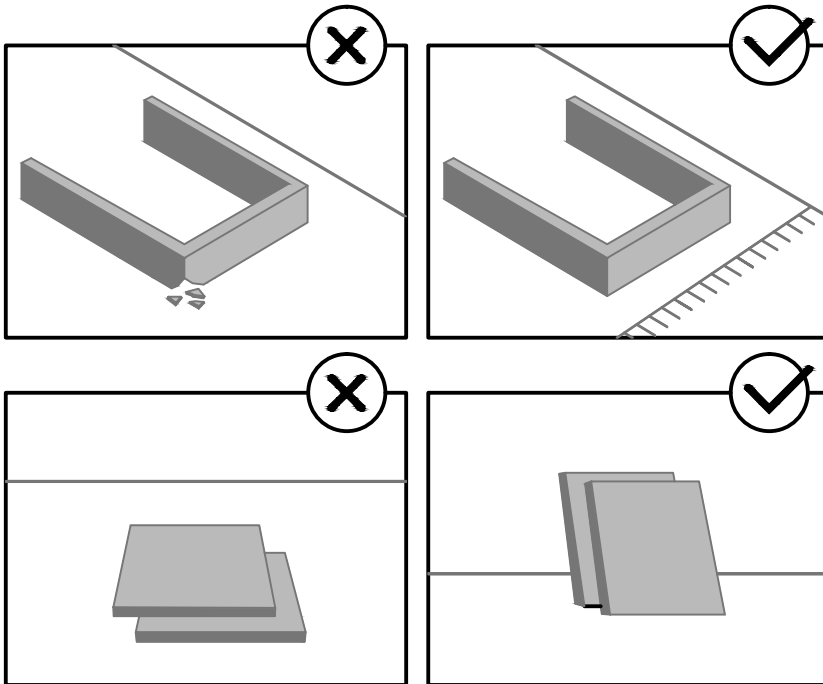

## TOOLS REQUIRED

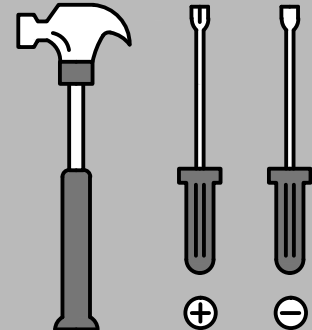

## SUPPORT SITE



View our assembly video online  
[WWW.MANHATTANCOMFORT.COM](http://WWW.MANHATTANCOMFORT.COM)



Stuck? Question? We are here to help.  
 tel: **908-888-0818**  
 e-mail: [help@manhattancomfort.com](mailto:help@manhattancomfort.com)

## Included in this package:

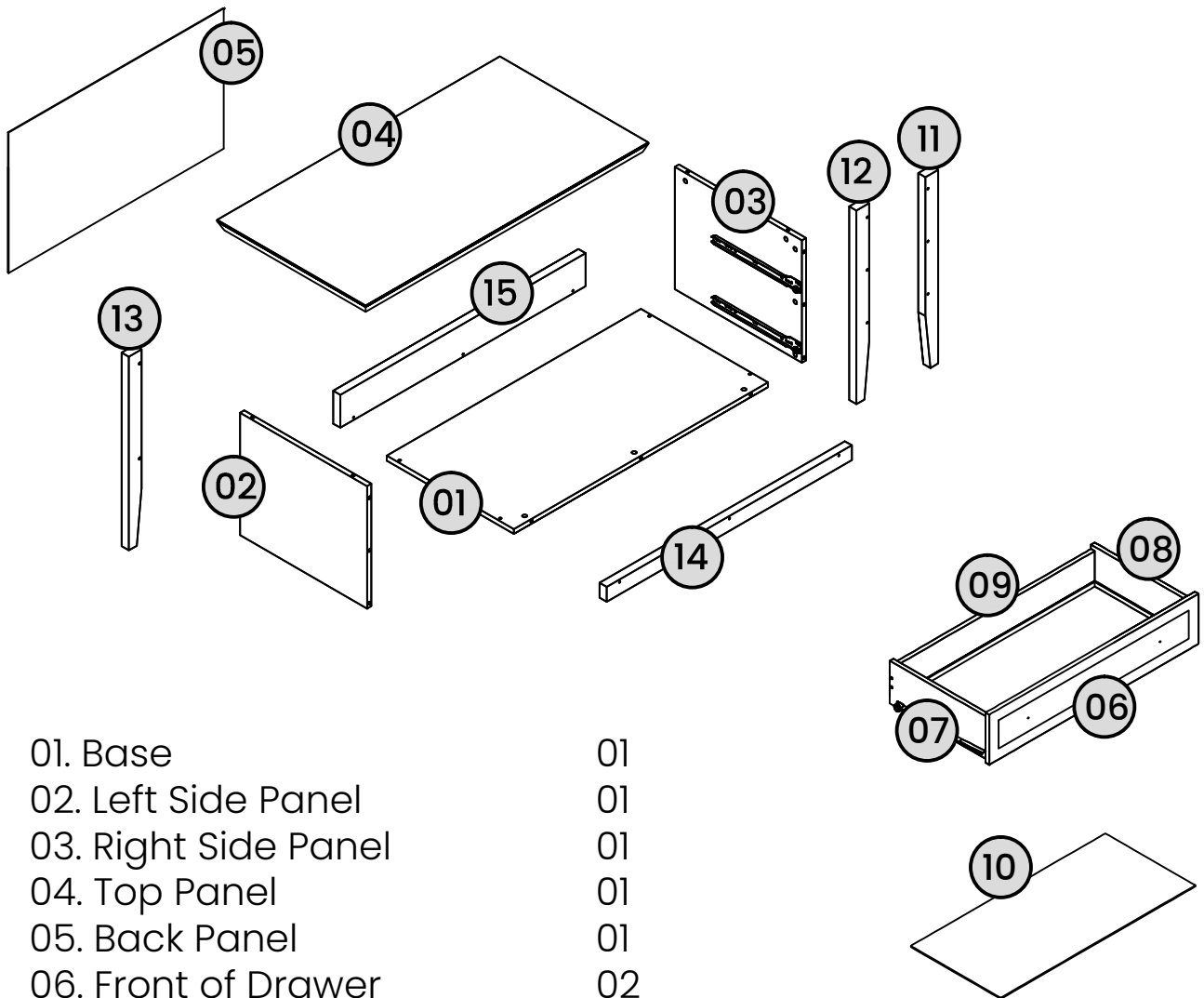

01. Base	01
02. Left Side Panel	01
03. Right Side Panel	01
04. Top Panel	01
05. Back Panel	01
06. Front of Drawer	02
07. Side of Drawer - Left	02
08. Side of Drawer - Right	02
09. Back of Drawer	02
10. Bottom of Drawer	02
11. Left Leg	01
12. Right Leg	01
13. Rear Leg	02
14. Front Bar	01
15. Rear Bar	01

## Included in this package:

---

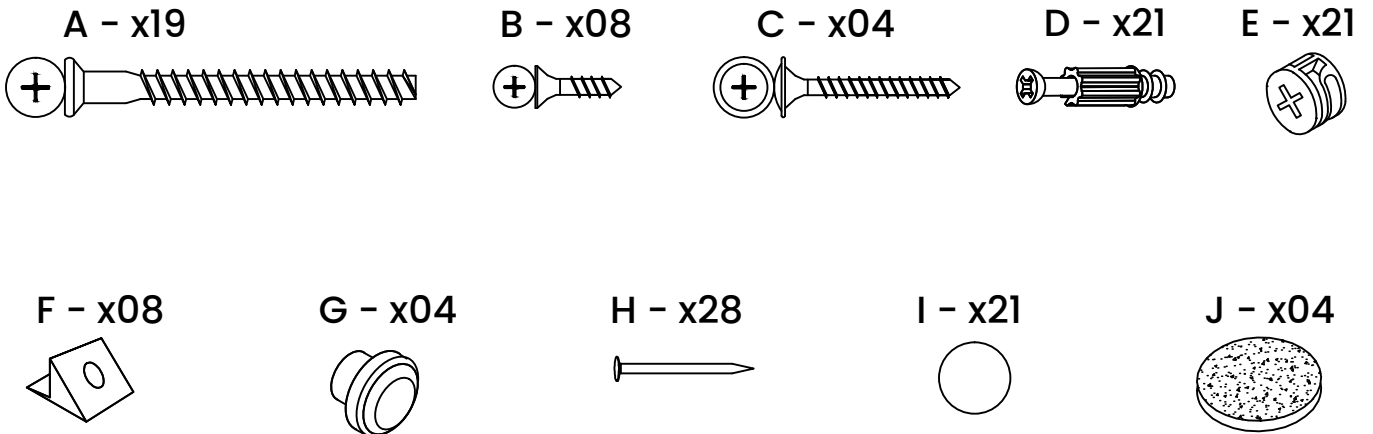

## Where to find the items:

---

BOX - 1		
01	11	F
02	12	G
03	13	H
04	14	I
05	15	J
06	A	
07	B	
08	C	
09	D	
10	E	

# Weight capacity:

---

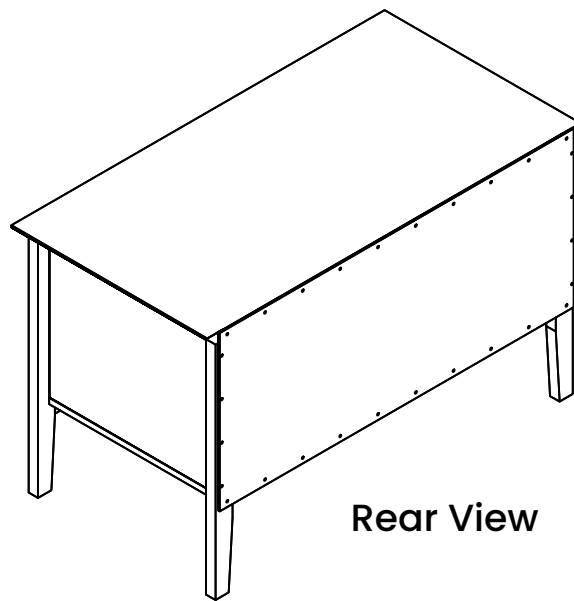
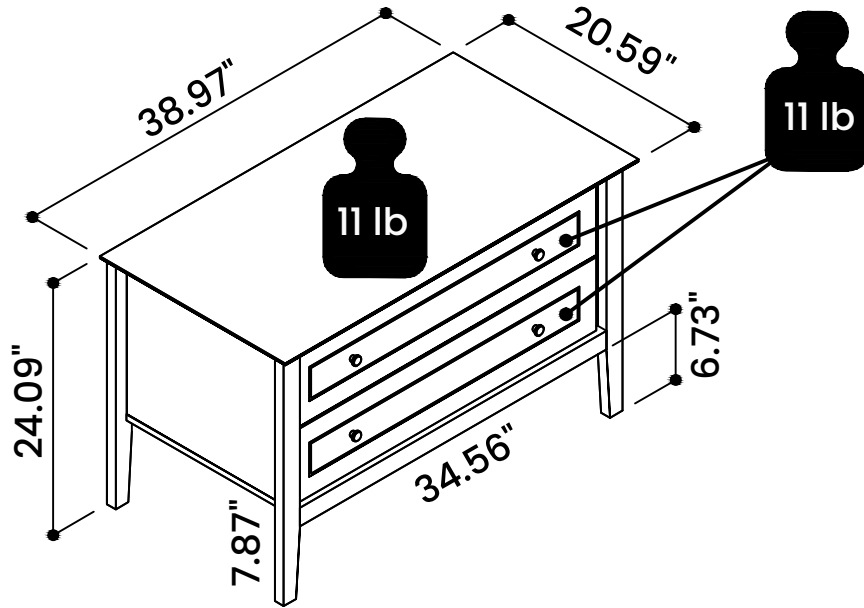

Rear View

## Step 01

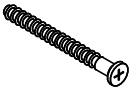

A = 04x

Connect the parts 13 onto the parts 02 and 03 with the hardware (A).

Pay attention to the position of the parts 13.

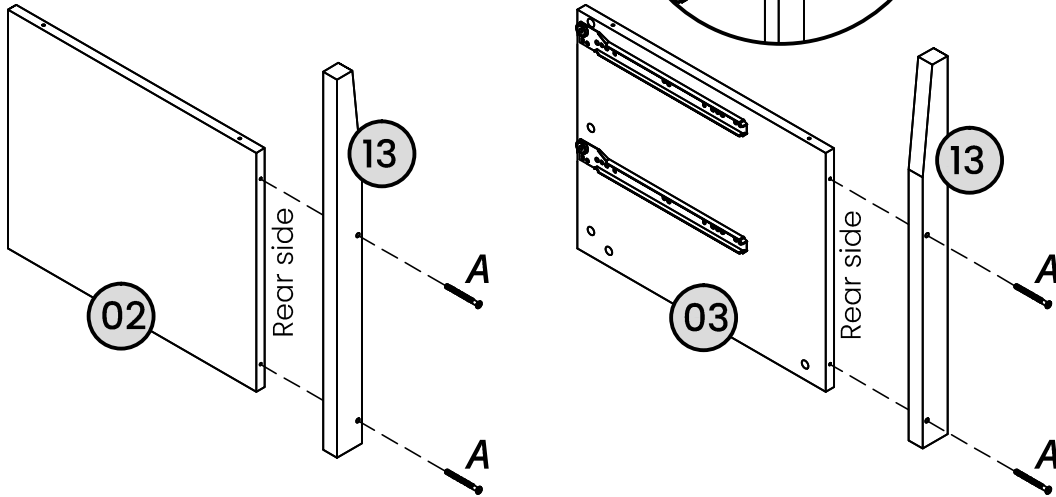
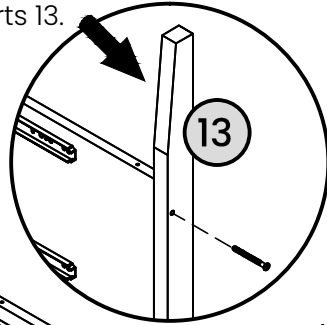

## Step 02



D = 09x

Apply the hardware (D) into the parts 11, 12 and 14.

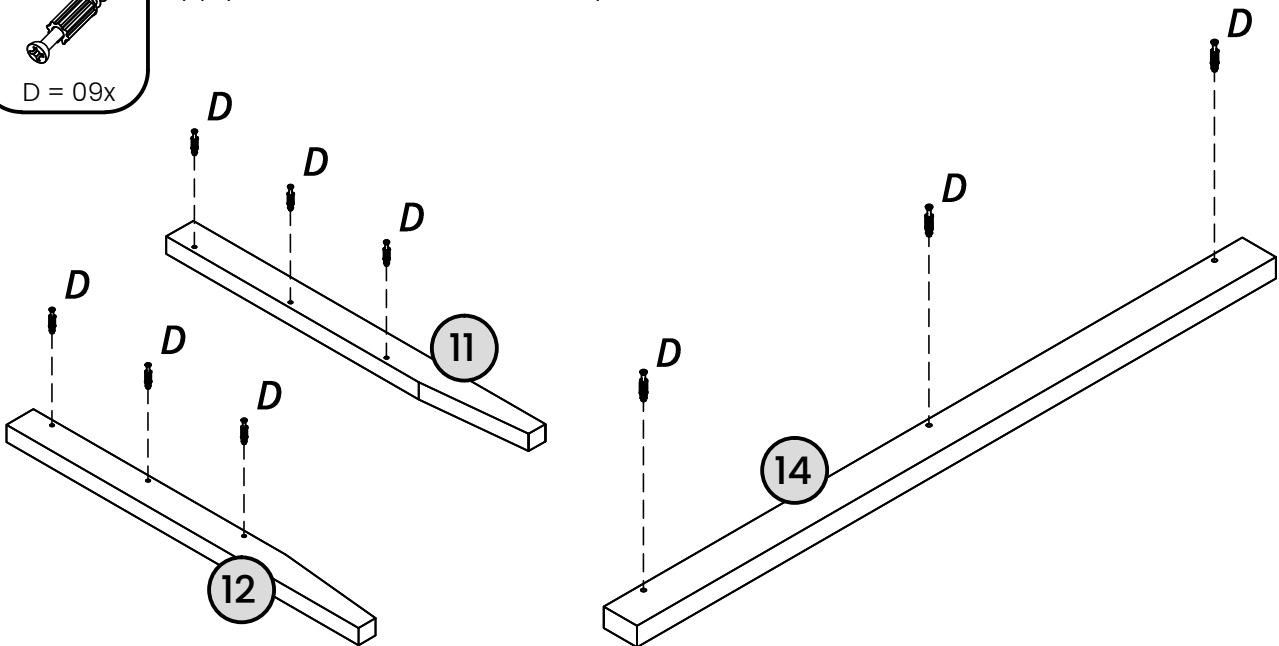

### Step 03



E = 03x



I = 03x

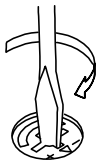

Connect the part 14 onto the part 01 with the hardware E.

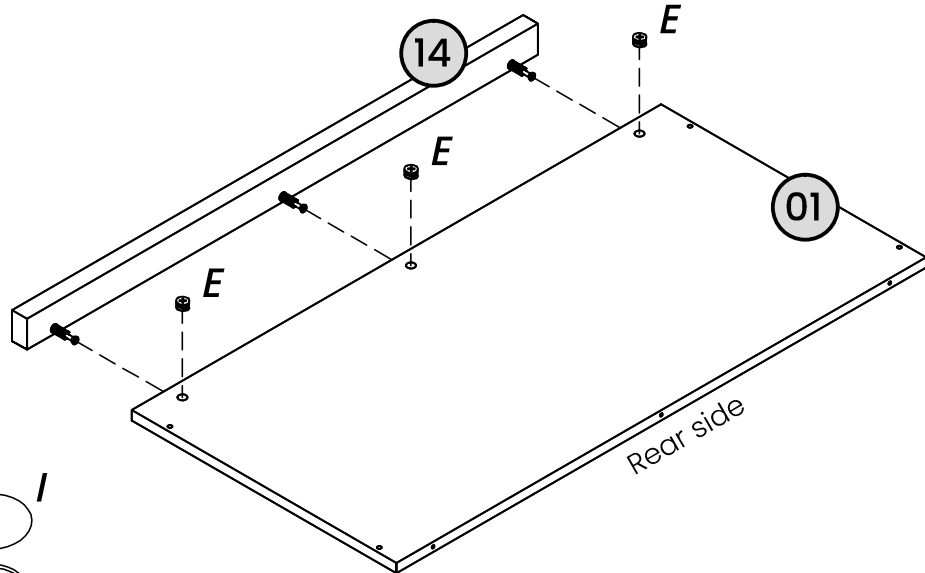

Apply the hardware (I) onto the hardware (E).

### Step 04

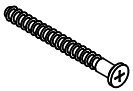

A = 03x

Connect the part 15 onto the part 01 with the hardware (A).

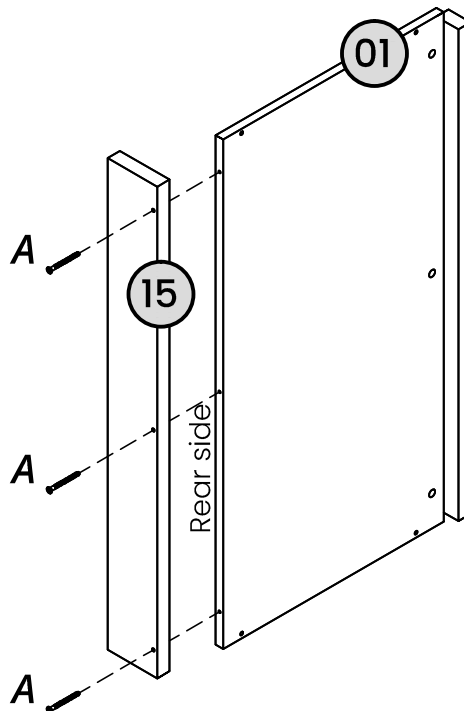

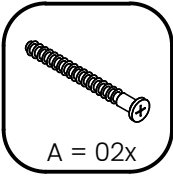
**Step 05**

Connect the part 02 onto the part 01 with the hardware (A).

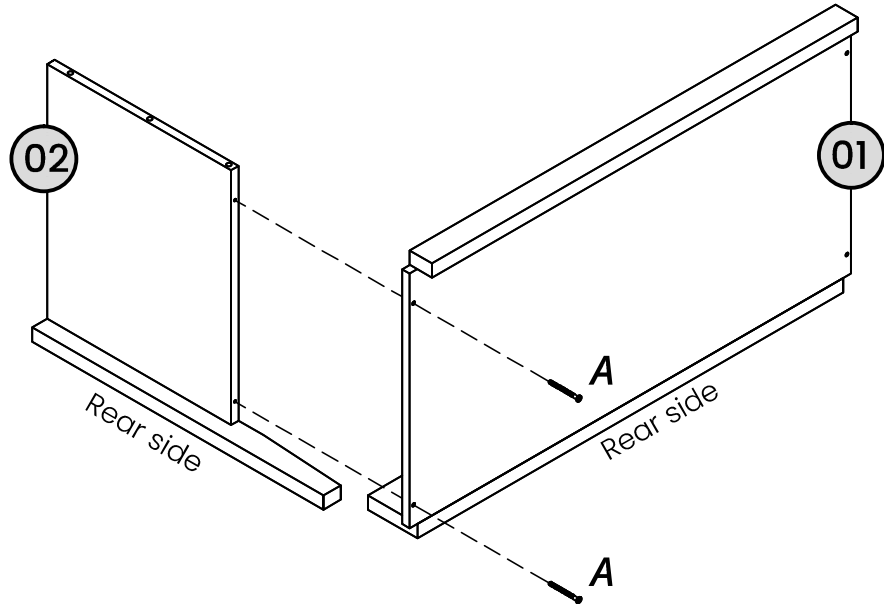
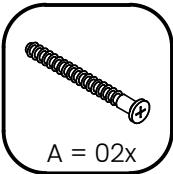
**Step 06**

Connect the part 03 onto the part 01 with the hardware (A).

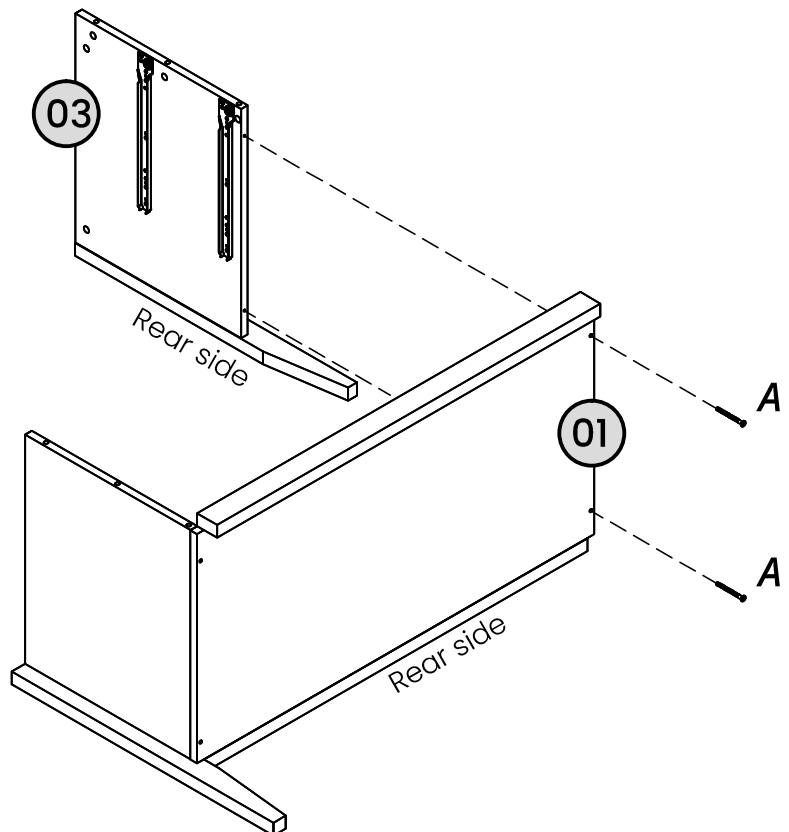

## Step 07

Connect the part 11 onto the part 02 with the hardware E.



E = 03x



I = 03x

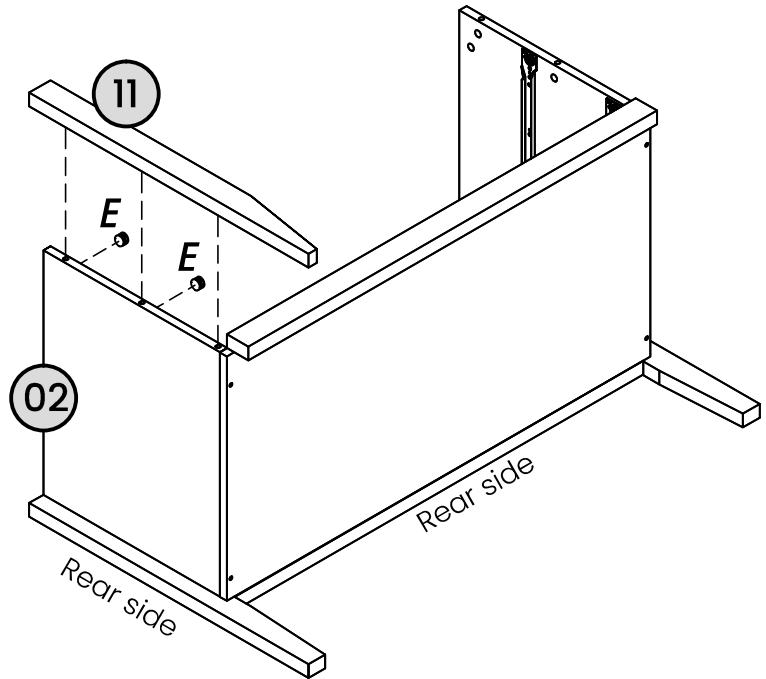
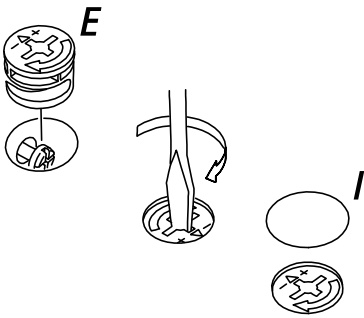

Apply the hardware (I) onto the hardware (E).

## Step 08

Connect the part 12 onto the part 03 with the hardware E.



E = 03x



I = 03x

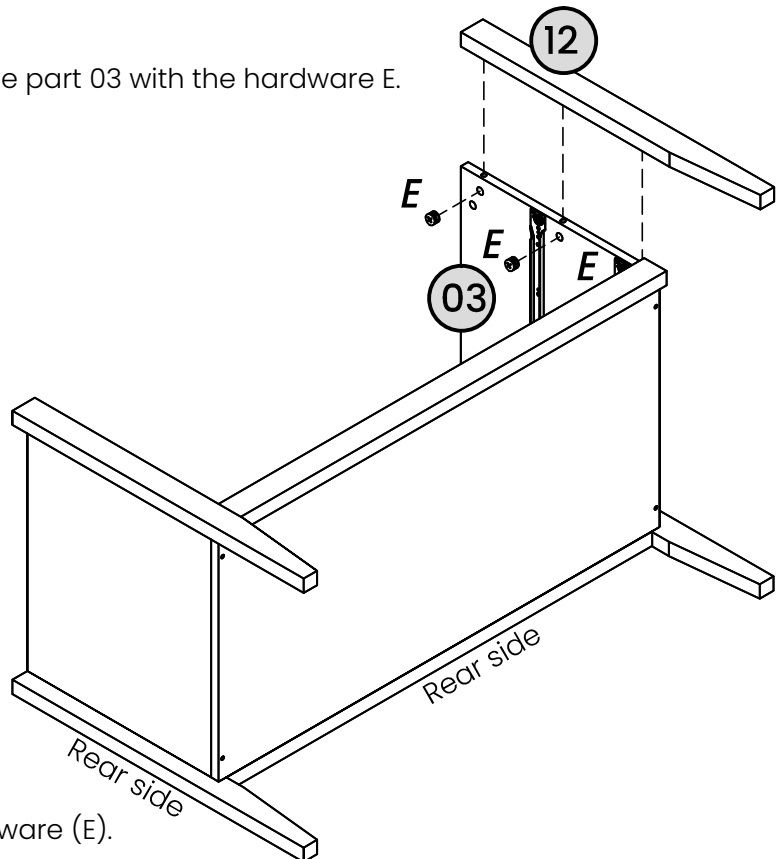
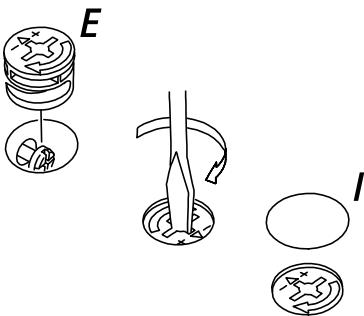

Apply the hardware (I) onto the hardware (E).

### Step 09



Apply the hardware (D) into the part 04.

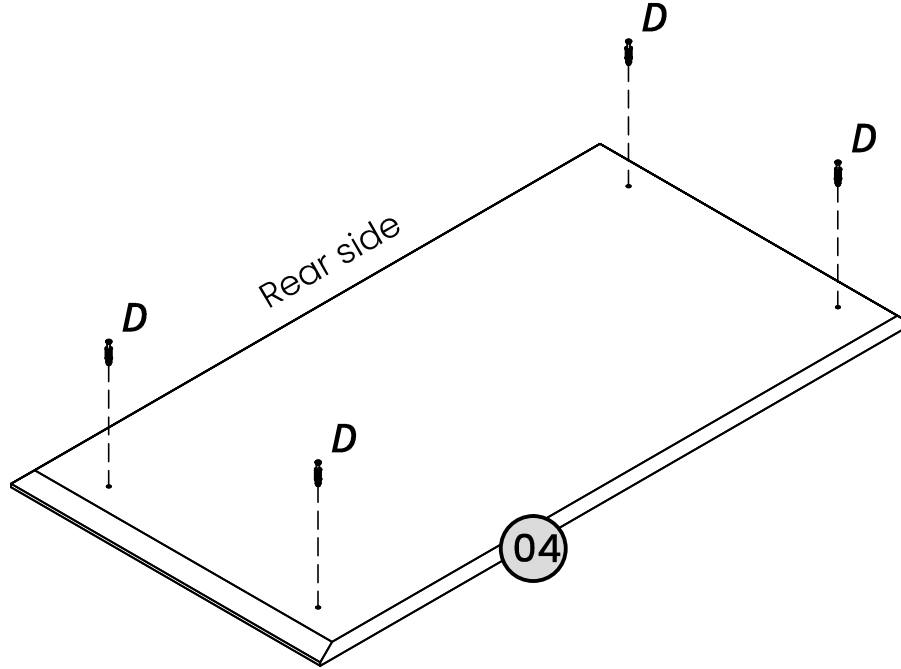

### Step 10

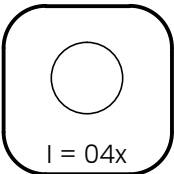

Connect the part 04 onto the parts 02 and 03 with the hardware E.

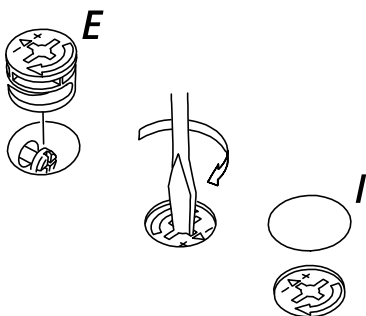
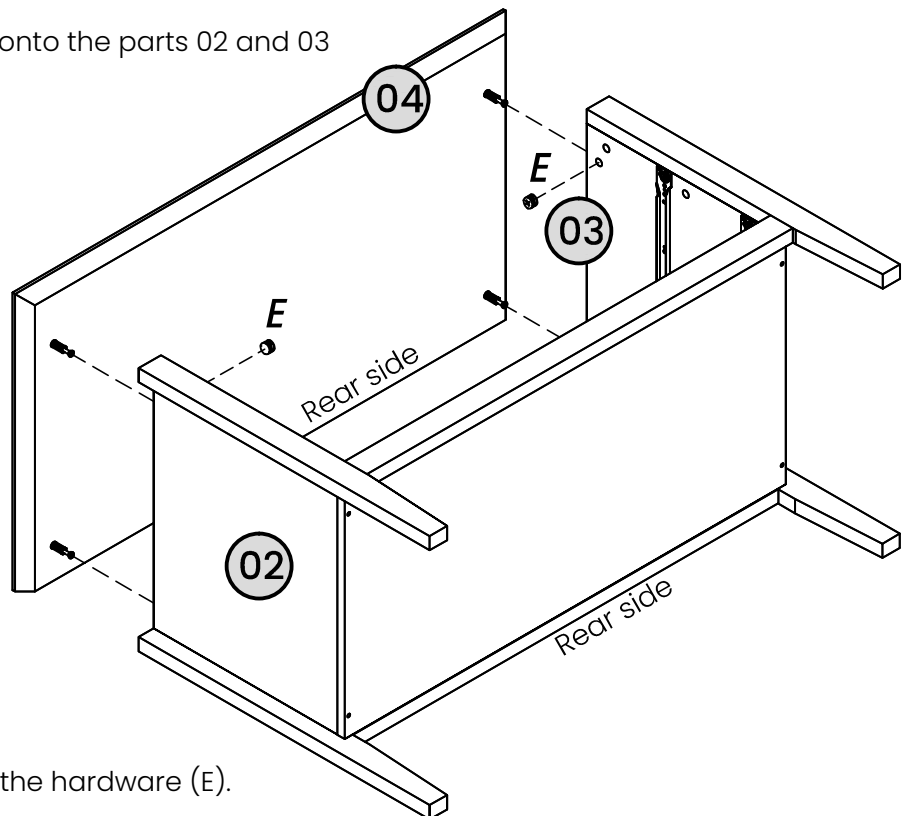

Apply the hardware (I) onto the hardware (E).

**Step 11**

J = 04x

Apply the hardware ( J ) into the parts 11, 12 and 13.

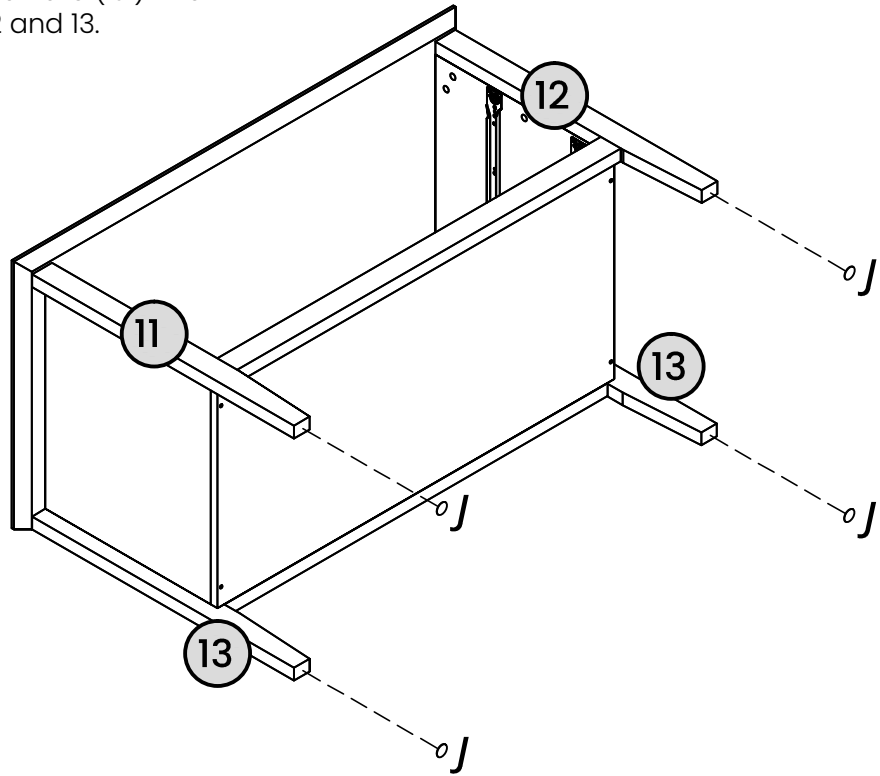
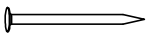
**Step 12**

H = 28x

Connect the part 05 with the hardware H.

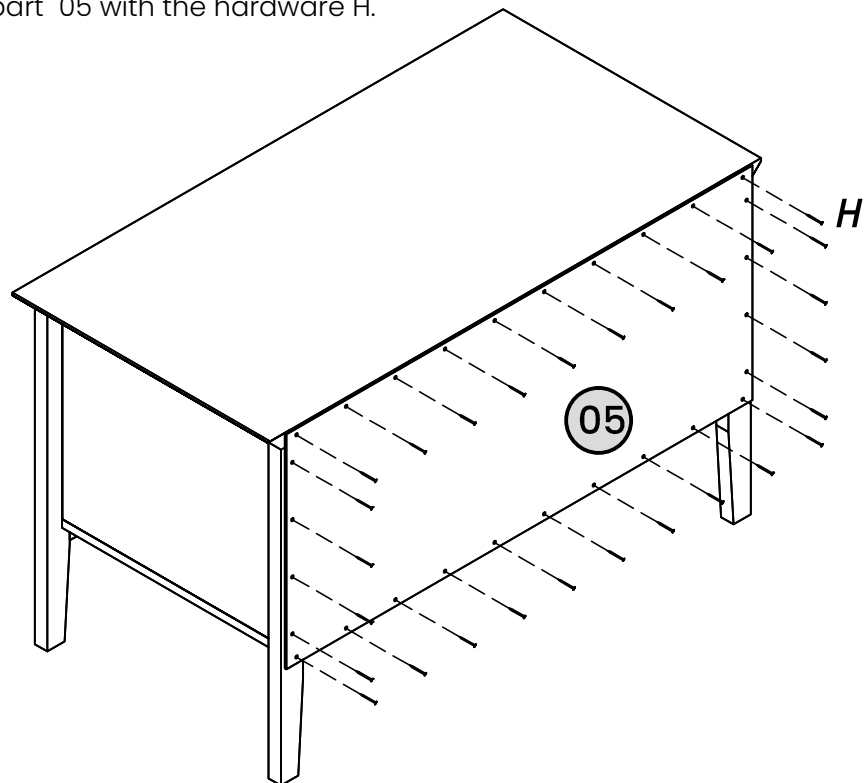

### Step 13

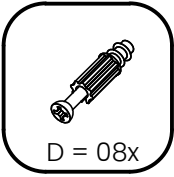

Apply the hardware (D) into the part 06.

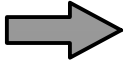

Attention:  
Assemble item on a soft surface,  
such as cardboard, Styrofoam board  
or carpet to avoid damage.

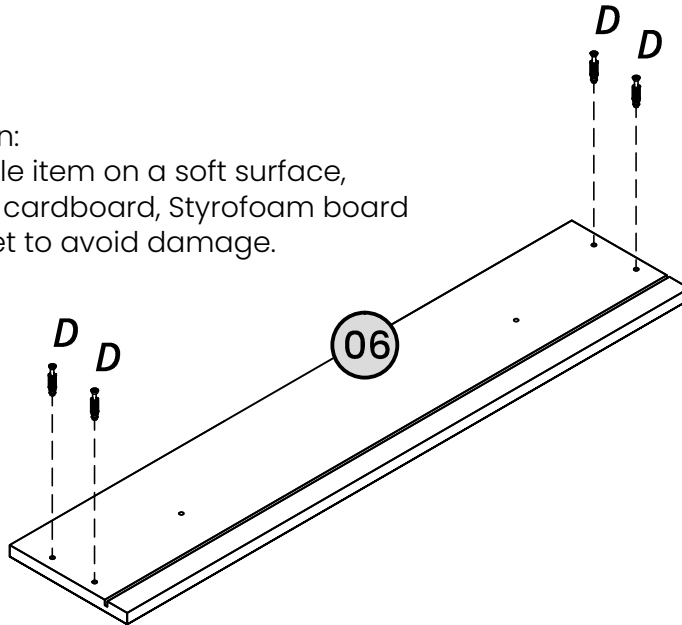

### Step 14

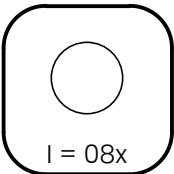

Connect the parts 07, 08 onto the part 06 with the hardware E.

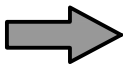

Attention:  
Assemble item on a soft surface,  
such as cardboard, Styrofoam board  
or carpet to avoid damage.

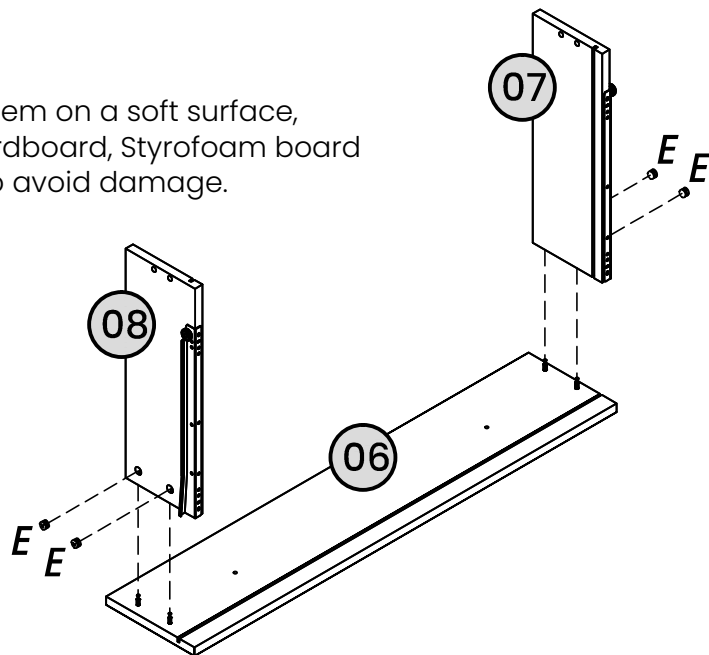
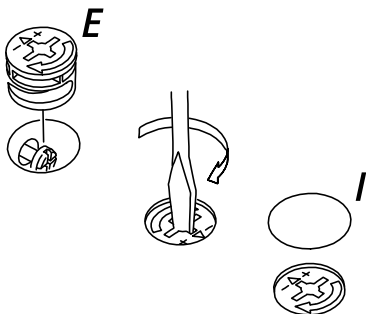

Apply the hardware (I) onto the hardware (E).

## Step 15

Apply the part 10 in the groove of the parts 07, 08 until the groove of the part 06.

Attention:

Assemble item on a soft surface, such as cardboard, Styrofoam board or carpet to avoid damage.

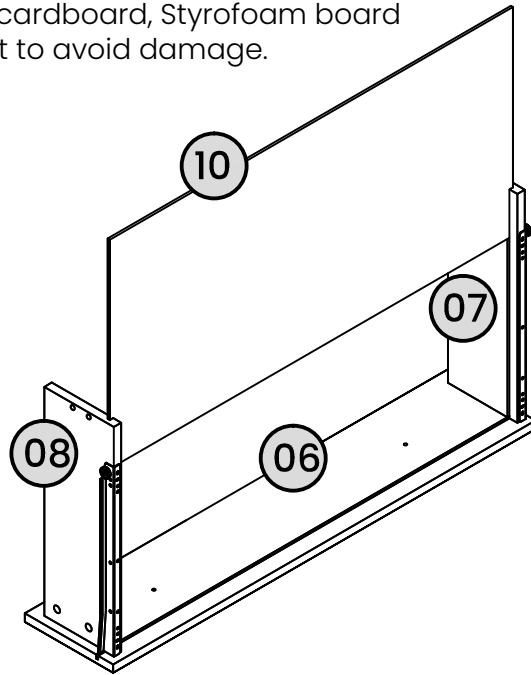
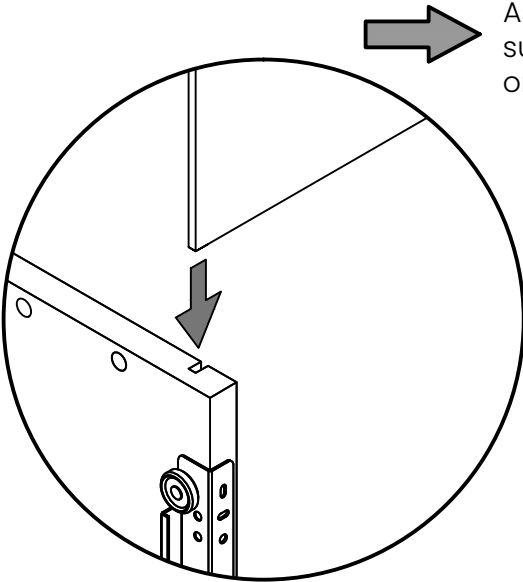

## Step 16

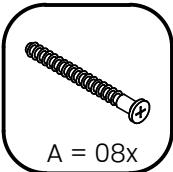

Connect the part 09 onto the parts 07, 08 with the hardware (A).

Attention:

Assemble item on a soft surface, such as cardboard, Styrofoam board or carpet to avoid damage.

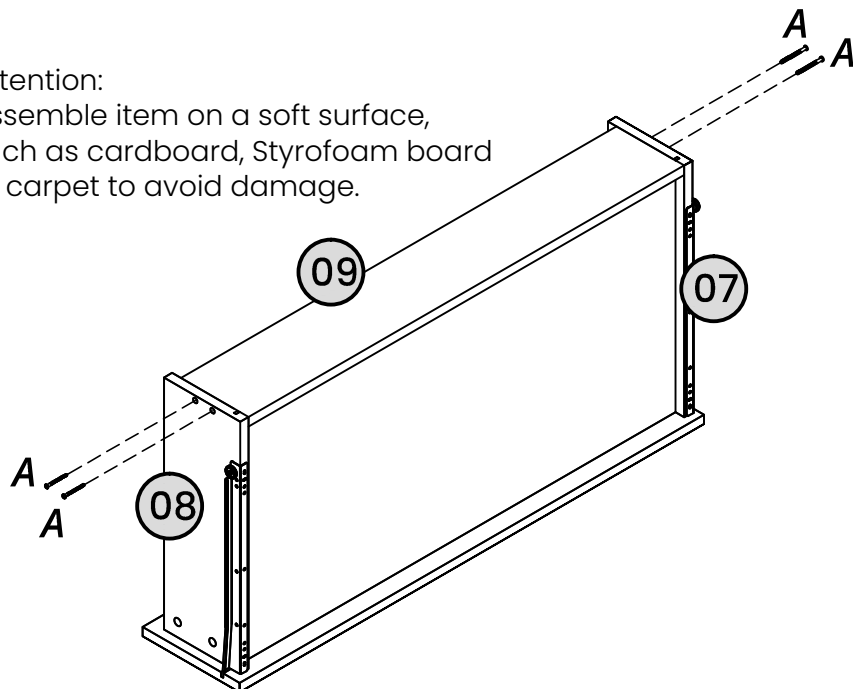
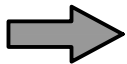

### Step 17



B = 08x

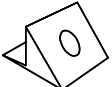

F = 08x

Apply the hardware (B + F) into the groove of the part 06 and 09 as shown on detail.

Attention:

Assemble item on a soft surface, such as cardboard, Styrofoam board or carpet to avoid damage.

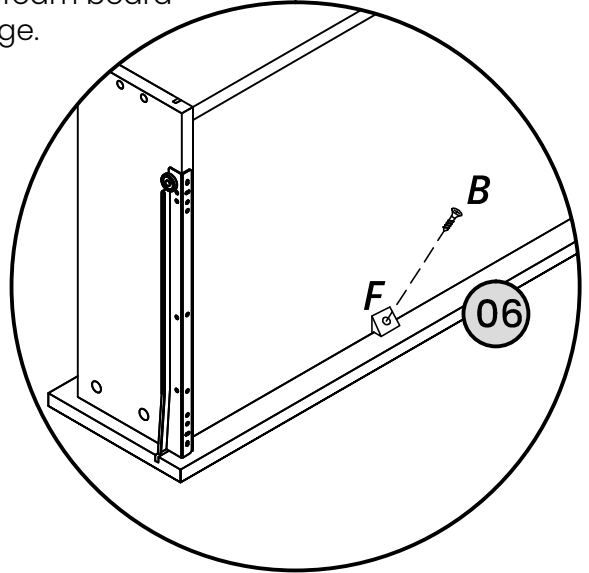
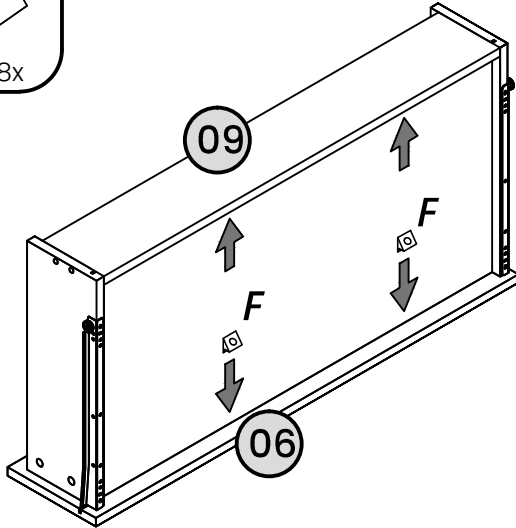

### Step 18



C = 04x

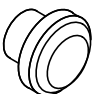

G = 04x

Apply the hardware (C + G) onto the front of the drawer.

Attention:

Assemble item on a soft surface, such as cardboard, Styrofoam board or carpet to avoid damage.

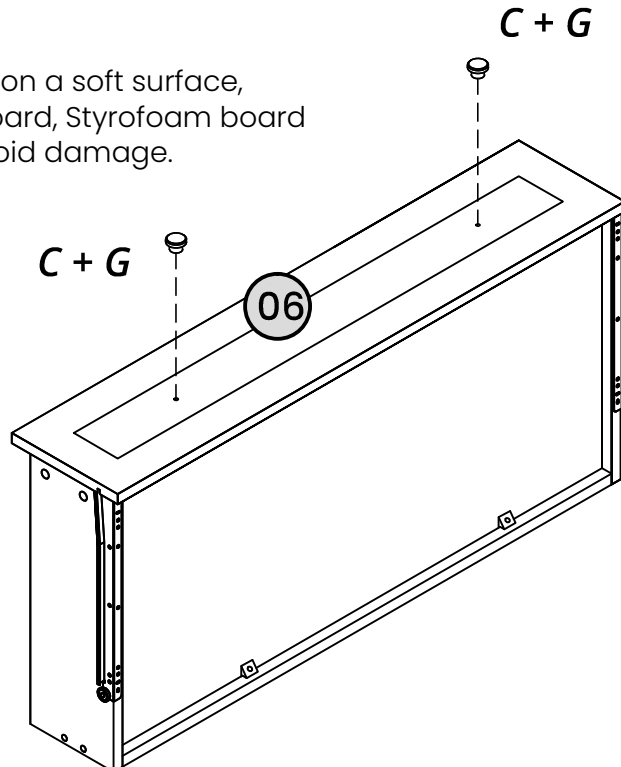



## **WARRANTY POLICY**

All Manhattan Comfort furniture products are warranted, to the original purchaser at the time of purchase and for a period of 30 days thereafter.

Our warranty is limited to new products purchased in factory sealed cartons. This warranty is valid in the United States of America and Canada.

In order to provide you with timely assistance, please thoroughly inspect your furniture for missing or defective parts immediately after opening the carton.

Manhattan Comfort offers a 30-day parts replacement warranty on all items.

Our furniture products are not intended for outdoor use.

### **THE WARRANTY DOES NOT COVER:**

- Defects/damages by improper assembly or disassembly.
- Defects/damages caused by shipping. Claims for damage during transit should be placed immediately to the transportation company.
- Defects/damages caused by inappropriate use of the furniture.



319 Ridge Rd. Dayton, NJ 08810

908-888-0818