

***Shark.* AI ROBOT**

Robot Vacuum

2000 Series

OWNER'S GUIDE



IMPORTANT SAFETY INSTRUCTIONS

PLEASE READ CAREFULLY BEFORE USE • FOR HOUSEHOLD USE ONLY

If the charging cable plug does not fit fully into the outlet, reverse the plug. If it still does not fit, contact a qualified electrician. **DO NOT** force into outlet or try to modify to fit.

⚠ WARNING

To reduce the risk of fire, electric shock, injury, or property damage:

GENERAL WARNINGS

When using an electrical appliance, basic precautions should always be followed, including the following:

1. This appliance consists of a robotic vacuum and charging dock with power supply. These components contain electrical connections, electrical wiring, and moving parts that potentially present risk to the user.
2. Before each use, carefully inspect all parts for any damage. If a part is damaged, discontinue use.
3. Use only identical replacement parts.
4. This robotic vacuum cleaner contains no serviceable parts.
5. Use only as described in this manual. **DO NOT** use the robotic vacuum cleaner for any purpose other than those described in this manual.
6. With the exception of filters, **DO NOT** expose any parts of the robotic vacuum cleaner to water or other liquids.

USE WARNINGS

7. This appliance can be used by persons with reduced physical, sensory or mental capabilities or lack of experience and knowledge if they have been given supervision or instruction concerning use of the appliance in a safe way and understand the hazards involved.
 - a) Children shall not play with the appliance.
 - b) Cleaning and user maintenance shall not be made by children without supervision.
8. Always turn off the robotic vacuum cleaner before inserting or removing the filter or dust bin.
9. **DO NOT** handle plug, charging dock, charging cable, or robotic vacuum cleaner with wet hands. Cleaning and user maintenance shall not be made by children without supervision.
10. **DO NOT** use without robot dust bin and filters in place.
11. **DO NOT** damage the charging cord:
 - a) **DO NOT** pull or carry charging dock by the cord or use the cord as a handle.
 - b) **DO NOT** unplug by pulling on cord. Grasp the plug, not the cord.
 - c) **DO NOT** close a door on the cord, pull the cord around sharp corners, or leave the cord near heated surfaces.
12. **DO NOT** put any objects into nozzle or accessory openings. **DO NOT** use with any opening blocked; keep free of dust, lint, hair, and anything that may reduce airflow.
13. **DO NOT** use if robotic vacuum cleaner airflow is restricted. If the air paths become blocked, turn the vacuum cleaner off and remove all obstructions before turning on the unit again.
14. Keep nozzle and all vacuum openings away from hair, face, fingers, uncovered feet, or loose clothing.
15. **DO NOT** use if robotic vacuum cleaner is not working as it should, or has been dropped, damaged, left outdoors, or dropped into water.
16. **DO NOT** place vacuum cleaner on unstable surfaces,
17. When manually moving the robot to a new location, it must be placed at least 1.5 feet (45 cm) away from any stairs or cliffs.
18. **DO NOT** use to pick up:
 - a) Liquid spills
 - b) Large objects
 - c) Hard or sharp objects (glass, nails, screws, or coins)
 - d) Large quantities of dust (drywall dust, fireplace ash, or embers). **DO NOT** use as an attachment to power tools for dust collection.
 - e) Smoking or burning objects (hot coals, cigarette butts, or matches)
 - f) Flammable or combustible materials (lighter fluid, gasoline, or kerosene)
 - g) Toxic materials (chlorine bleach, ammonia, or drain cleaner)
19. **DO NOT** use in the following areas:
 - a) Outdoor areas near fireplaces with unobstructed entrances
 - b) Spaces that are enclosed and may contain explosive or toxic fumes or vapors (lighter fluid, gasoline, kerosene, paint, paint thinners, mothproofing substances, or flammable dust
 - c) In an area with a space heater
 - d) Near fireplaces with unobstructed entrances
 - e) On wet or slippery surfaces
20. Turn off the robotic vacuum cleaner before any adjustment, cleaning, maintenance or troubleshooting. Note: in the OFF (O) position, the robot still uses a small amount of power.

21. Allow all filters to air-dry completely before replacing in the robotic vacuum cleaner to prevent liquid from being drawn into electric parts.
22. **DO NOT** modify or attempt to repair the robotic vacuum cleaner or the battery yourself, except as indicated in this manual. **DO NOT** use the vacuum if it has been modified or damaged.
23. Remove all spilled or leaked liquid from the base or floor, as it could lead to risk of electrical shock.
24. For your robot's cliff sensors to work properly, all runners, rugs, carpets, or small thresholds (like child gates) must be 8 inches from any stairs (or must be continuous and extend over the edge of the stairs). If a runner, rug, carpet, or small threshold that is less than 8 inches from the stairs cannot be moved, you must use a no-go zone or a BotBoundary strip to block off the stairs. BotBoundary strips are not included with your robot but can be purchased by contacting Shark Customer Service at 1-888-668-9600.

BATTERY USE

25. The battery is the power source for the vacuum. Carefully read and follow all charging instructions.
26. To prevent unintentional starting, ensure the vacuum is powered off before picking up or carrying the vacuum. **DO NOT** carry the appliance with your finger on the power switch.
27. Use **ONLY** the Shark® charging dock XDCKRV2000 and use only battery RVBAT850A. Use of batteries or battery chargers other than those indicated may create a risk of fire.
28. Keep the battery away from all metal objects such as paper clips, coins, keys, nails, or screws. Shorting the battery terminals together increases the risk of fire or burns.
29. Under abusive conditions, liquids may be ejected from the battery. Avoid contact with this liquid, as it may cause irritation or burns. If contact occurs, flush with water. If liquid contacts eyes, seek medical help.

30. Robotic vacuum cleaner should not be stored, charged, or used at temperatures below 50°F (10°C) or above 104°F (40°C). Ensure the battery and vacuum have reached room temperature before charging or use. Exposing the robot or battery to temperatures outside of this range may damage the battery and increase the risk of fire.
31. **DO NOT** expose the robotic vacuum cleaner or battery to fire or temperatures above 265°F (130°C) as it may cause explosion.
32. Non-rechargeable batteries cannot be recharged.

NO-GO ZONES AND BOTBOUNDARY® STRIPS

33. **DO NOT** put BotBoundary strips underneath carpet or rugs.
34. **DO NOT** place BotBoundary strips on top of one another.
35. Always use no-go zones or BotBoundary strips around reflective flooring and surfaces.
36. No-go zones or BotBoundary strips should always be used near carpeted stairs.
37. **DO NOT** place no-go zones or BotBoundary strips within 10 feet of the dock.
38. For your robot's cliff sensors to work properly, all runners, rugs, carpets, or small thresholds (like child gates) must be 8 inches from any stairs (or must be continuous and extend over the edge of the stairs). If a runner, rug, carpet, or small threshold that is less than 8 inches from the stairs cannot be moved, you must use a no-go zone or a BotBoundary strip to block off the stairs.

LASER WARNINGS

39. This product has a Class 1 laser. It is safe under reasonably foreseeable conditions (as defined in this Owner's Guide.) Always turn off the power before lifting the robotic vacuum cleaner or performing any maintenance on it.
40. **DO NOT** look directly into laser.

SAVE THESE INSTRUCTIONS

For the latest warnings and cautions, go to support.sharkninja.com

GETTING TO KNOW YOUR SHARK® AI ROBOT

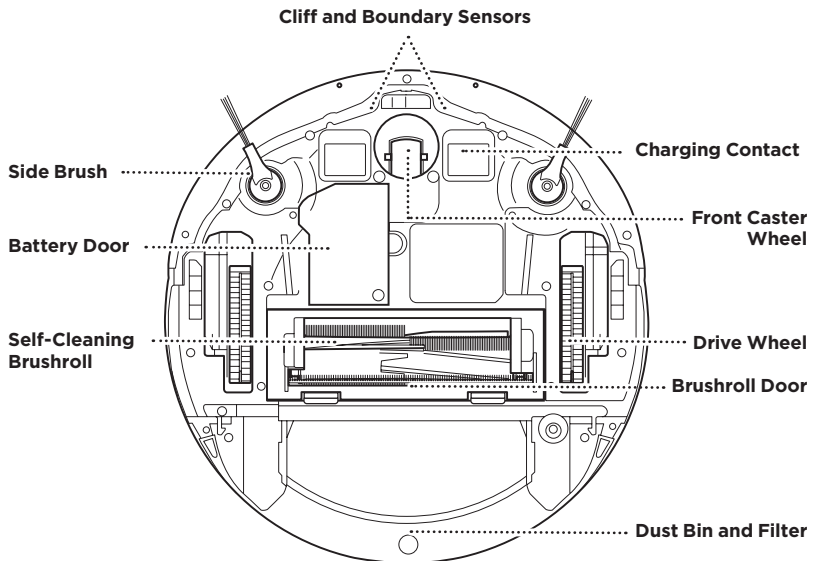
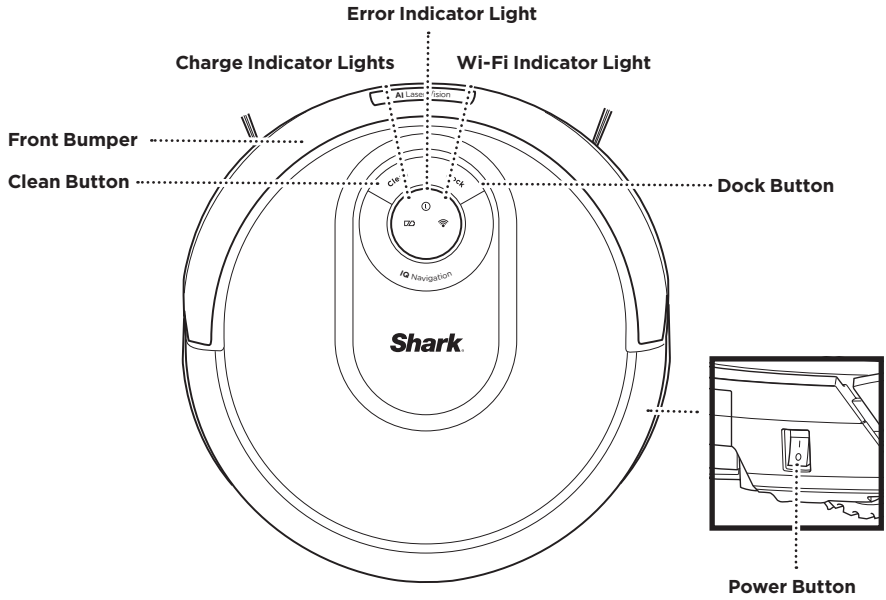

DOCK FRONT

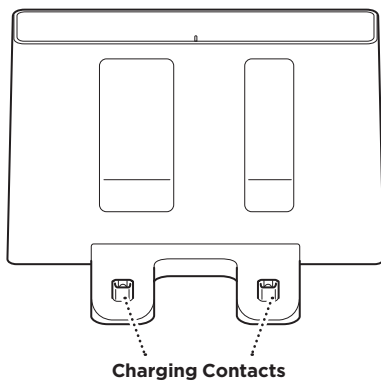

DOCK BOTTOM

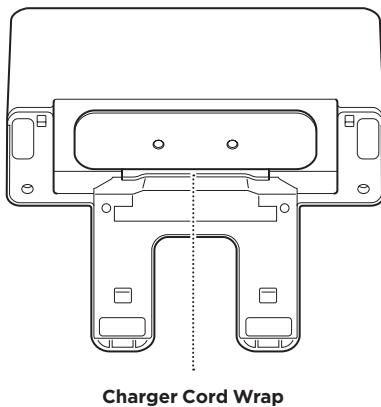

DOCK SETUP

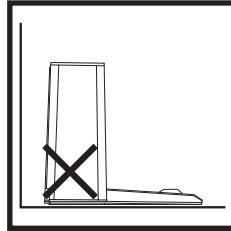
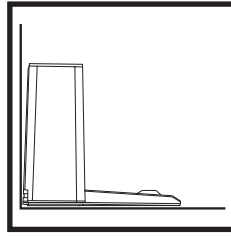
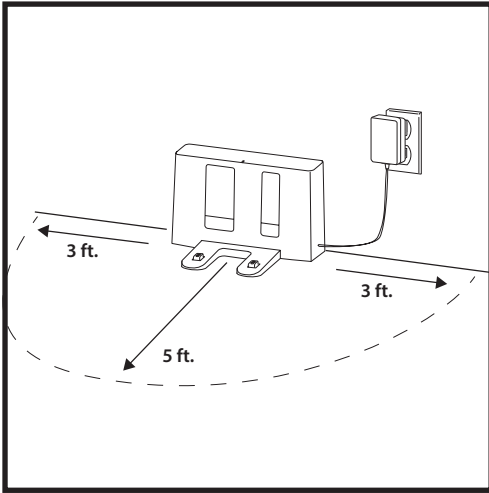

- Select a permanent location for the **Charging Dock**, because every time you relocate it, your robot will have to completely re-map your house.
- Place the dock with its back against a wall. Select a level surface on bare floor, in a central area. Do not place dock against baseboards or heating elements.
- Remove any objects that are closer than 3 feet from either side of the dock, or closer than 5 feet from the front of the dock.
- Plug in the dock. The indicator light will illuminate green when the dock has power.

INSTALLING THE SIDE BRUSHES

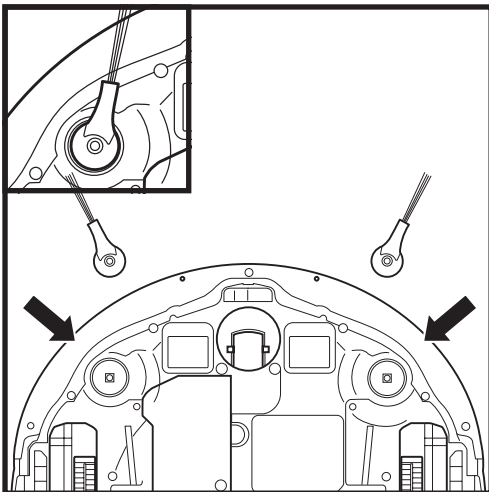

Snap the 2 included **Side Brushes** onto the square pegs on the bottom of the robot.

CHARGING

IMPORTANT: The Shark® AI Robot has a pre-installed rechargeable battery. Charge the battery completely before first use. It may take up to 6 hours to fully charge.

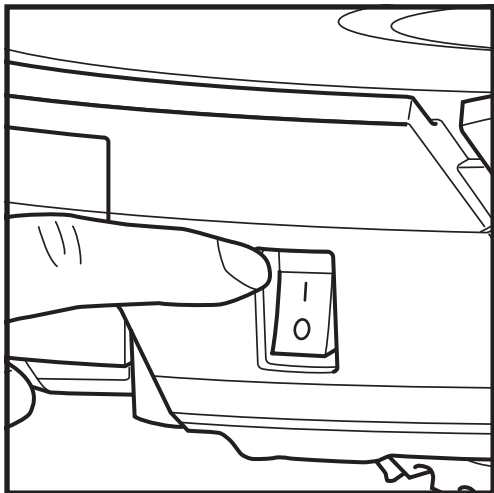

To charge, place the robot on the dock. The **Power** button on the side of the robot must be in the ON position (I). The robot will beep when charging begins.

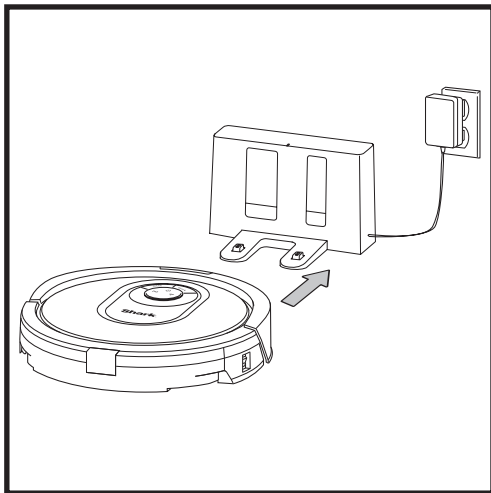

When the cleaning cycle is complete, the battery is low, or when programmed to in a recharge/resume mission, the robot will search for the dock. If the robot doesn't return to dock, its charge may have run out.

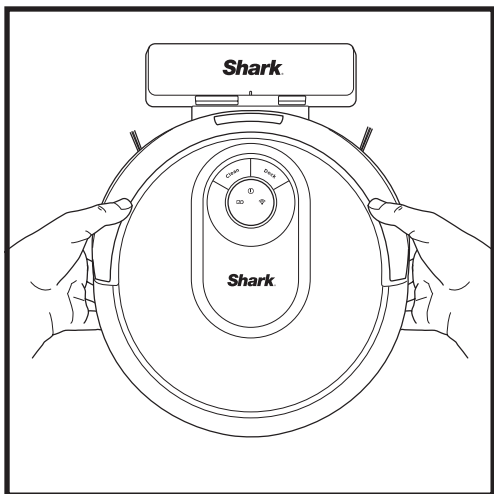

If the robot has no charge or it cannot return to the dock, manually place it on the dock. The indicator light on the dock will change to blue and the robot will beep when charging begins.

NOTE: When manually placing the robot on the dock, make sure the **Charging Contacts** on the bottom of the robot are touching the ones on the dock. While the robot is charging, both white LED lights will flash. When charging is complete, lights will illuminate steadily.

NOTE: When picking up the robot, be careful not to place fingers between the bumper and the base of the robot.

CHARGE INDICATOR LIGHTS

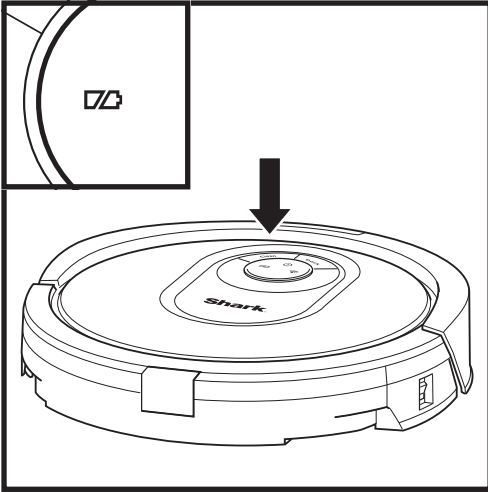

In Use



Full Charge
(White)



Partial Charge
(White)



Low Charge
(Red)

While Charging (White)



No Charge or Off



The white charge indicator lights show how much battery power is remaining.

While the robot is charging, both white LED lights will flash. When charging is complete, both will illuminate steadily. It may take up to 6 hours to fully charge your robot.

If the robot is idle and away from the charging dock for 10 minutes, it will enter **Sleep Mode**. The indicator lights will turn off, but the battery and Wi-Fi lights will remain on in sleep mode. Wake up the robot by pressing any button.

NOTE: If the low charge light is blinking red, there is not enough battery power for the robot to return to the dock. Manually place the robot on the dock.

TIP: To preserve battery life, turn off the power switch if the robot will not be used for a long period of time. The robot should be recharged at least once every three months. The switch must be in the ON position to charge the robot.

IMPORTANT: Before cleaning an entire room for the first time, we recommend that you first test your robot on a small section of the floor to ensure there is no scratching.

BUTTONS AND INDICATOR LIGHTS

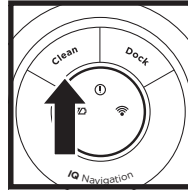
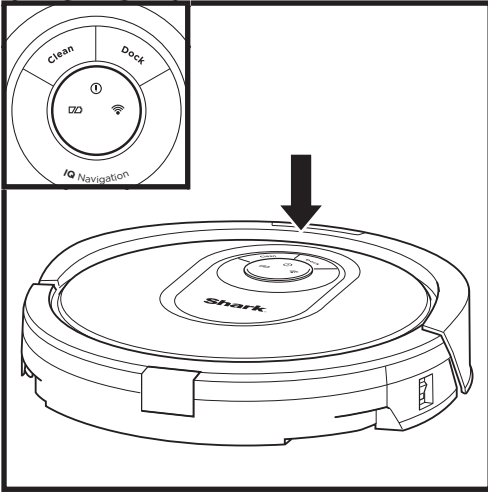

CLEAN BUTTON

Press to begin a cleaning session. Press again to stop.

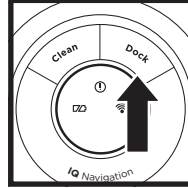

DOCK BUTTON

Press to stop cleaning and send robot back to the charging dock.

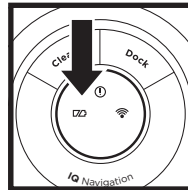

CHARGE INDICATOR LIGHTS

Display the amount of charge remaining in the battery.

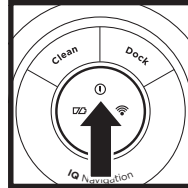

“!” ERROR INDICATOR

See Troubleshooting section for full list of error codes.

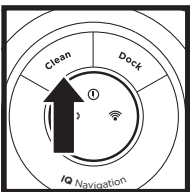

RECHARGE & RESUME

Press and hold the CLEAN button for 15 seconds to turn Recharge & Resume ON or OFF.

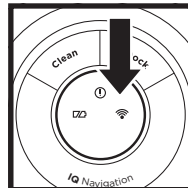

WI-FI INDICATOR

White light: connected to Wi-Fi.

Red light: not connected.

Flashing White: setup mode.

No light: not set up yet.

The Recharge & Resume function is turned OFF by default. Turn ON Recharge & Resume for complete coverage if your home's floor plan is bigger than 1500 sq. ft. Your robot will return to the dock, recharge, and can pick up where it left off.

PREP YOUR HOME

Your robot uses an array of sensors to navigate around walls, furniture legs, and other obstacles while it cleans. To prevent the robot from entering areas you don't want it to, set up no-go zones in the app. For best results, prepare your home as indicated below, and schedule a daily cleaning to ensure all floor areas are regularly maintained.

NOTE: Scheduling is one of many features that can only be done in the app.

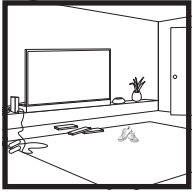

OBSTRUCTIONS

Clear cords and objects smaller than 2.8" in height from floors and open interior doors to ensure a complete map of your home.

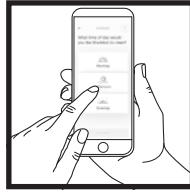

SCHEDULING

Schedule whole-home vacuuming runs with the app.

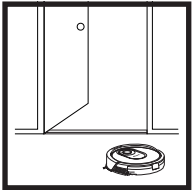

THRESHOLDS

Your robot can easily climb over most thresholds, but if one is too high, set up a no-go zone in the app to block it off.



AVOID MOVING THE ROBOT & DOCK

While your robot is cleaning, do not pick it up and move it, or move the charging dock—this will impact the robot's navigation and ability to return to dock when cleaning is complete.

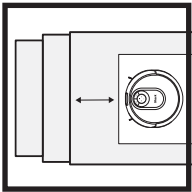

STAIRS

For your robot's cliff sensors to work properly, all runners, rugs, carpets, or small thresholds (like child gates) must be 8 inches from any stairs (or must be continuous and extend over the edge of the stairs). If a runner, rug, carpet, or small threshold that is less than 8 inches from the stairs cannot be moved, you must use a no-go zone or a BotBoundary strip to block off the stairs.

USING THE SHARK® AI ROBOT

IQ NAVIGATION™ AND AI LASER VISION

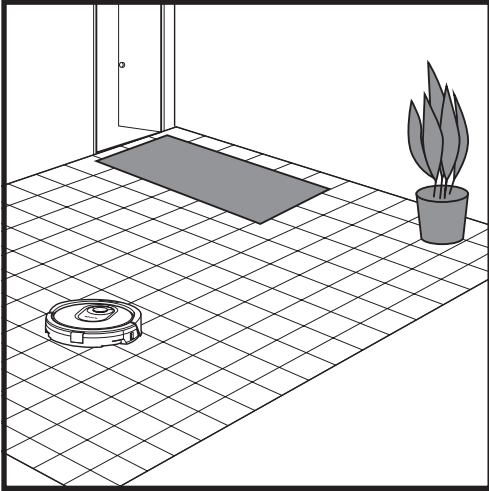

After setup is complete, your robot will conduct an **Explore Run** to create an initial map of your home. The robot will travel from room to room to identify walls, furniture, and other obstacles as it cleans. This run will take less time than a full cleaning, as it doesn't cover the entire floor.



The robot's object detection technology helps it navigate around obstacles taller than 2.8" in height. Create no-go zones in the app to block off areas you do not want the robot to enter. You can set up no-go zones around small objects, or use them to block off large areas.

MANUAL CLEANING MODE

To manually start a cleaning cycle, press the **Clean** button on the robot or on the mobile app. To immediately send the robot back to the dock, press the Dock button.

NOTE: Be sure to charge the robot completely before its first cleaning so that it can explore, map, and clean as much of your home as possible. It may take up to 6 hours to fully charge your robot.

NOTE: Avoid moving the dock. If it is relocated, the robot may not be able to find its way back to the dock. If the robot is relocated while in use, it may not be able to follow its intelligent cleaning path, or find its way back to the dock.

USING THE SHARK® AI ROBOT

Please visit support.sharkninja.com or call 1-888-668-9600 for answers to all your app questions.

USING THE SHARKCLEAN™ APP AND VOICE CONTROLS

Get the most out of your Shark AI Robot with these app features:



- **Recharge and Resume**
Enable this feature to handle multi-room cleaning in larger homes. The robot will return to the dock, recharge, and can pick up where it left off.
- **Go Zones, No-Go Zones**
Use the no-go zones in the app to keep your robot out of the areas you would like it to avoid.

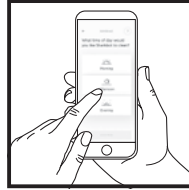

- **Scheduling**
Set whole-home cleanings for any time, any day.
- **Control From Anywhere**
Wherever you are, you're in control of your robot.
- **Cleaning Reports**
Each time your robot cleans, your app will generate a cleaning report.

Search for **SharkClean** in the app store and download the app to your iPhone™ or Android™.



SETTING UP VOICE CONTROL WITH THE GOOGLE ASSISTANT OR AMAZON ALEXA

Visit support.sharkninja.com for setup instructions which include how to enable Shark Skill for Amazon Alexa and using with Google Assistant.

Google Assistant:

- “OK Google, tell Shark to start cleaning.”
- “OK Google, tell Shark to pause my robot.”
- “OK Google, tell Shark to send my robot to the dock.”

Amazon Alexa:

- “Alexa, tell Shark to start cleaning.”
- “Alexa, tell Shark to pause my robot.”
- “Alexa, tell Shark to send my robot to the dock.”

WI-FI TROUBLESHOOTING

- To use the app, your phone must be connected to a 2.4GHz network. The app will only work on a 2.4GHz network.
- Typical home Wi-Fi networks support both 2.4GHz and 5GHz.
- Do not use a VPN or a proxy server.
- Make sure Wi-Fi isolation is turned off on the router.
- If you cannot connect, call 1-888-668-9600.

ERROR CODE	PROBLEM
! (RED) + Wi-Fi indicator (RED Flashing)	Wrong password for Wi-Fi
! (Flashing red) + Wi-Fi (RED)	SSID cannot be found, try connecting again
! + Wi-Fi (Flashing RED at the same time)	Cannot connect to Wi-Fi

MAINTENANCE

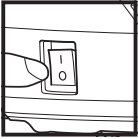

CAUTION: Turn off power before performing any maintenance.

NOTE: in the OFF (O) position, the robot still uses a small amount of power.

EMPTYING THE DUST BIN

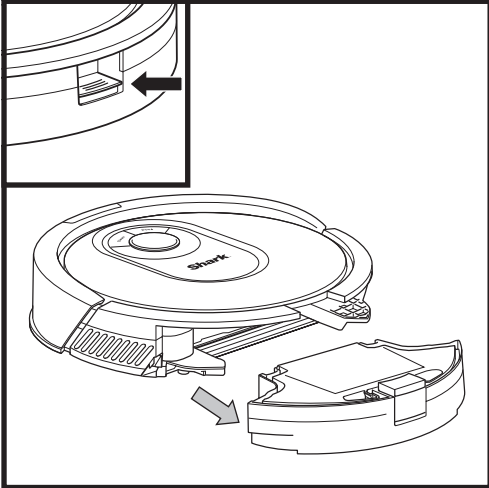

Press the **Dust Bin Release Button** and slide out the dust bin.

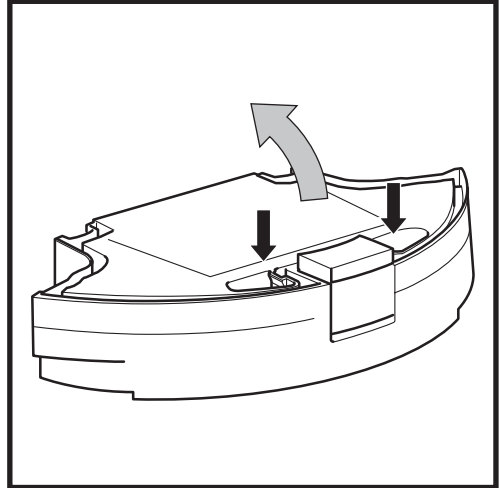

To open the dust bin lid, press and hold the button while lifting the lid, using the finger slots.

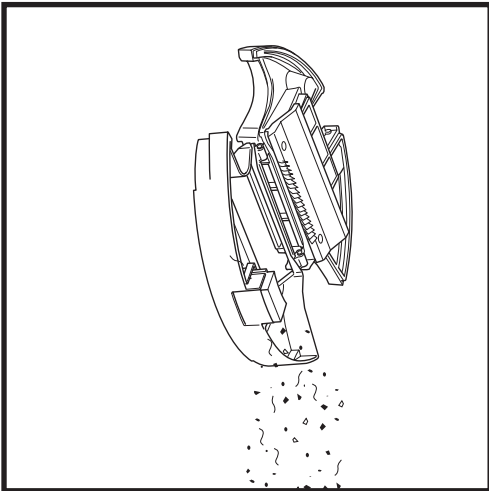

Empty debris and dust into trash. Remove filter and wash dust bin if necessary.

NOTE: Make sure to insert the dust bin completely, until it clicks into place.

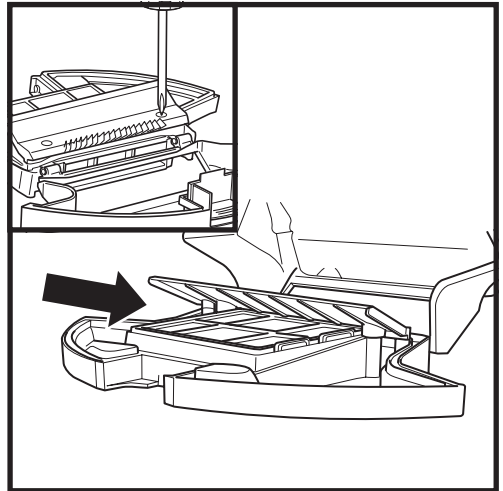

Look between the filter and the plastic shield and make sure there is no debris buildup.

Remove shield and clear any debris buildup with a dry cloth or soft brush.

MAINTENANCE

CLEANING AND REPLACING THE FILTER

For optimal suction power, after each use, clean and reinsert the filter inside the robot's dust bin.
See sharkaccessories.com for replacement filters.

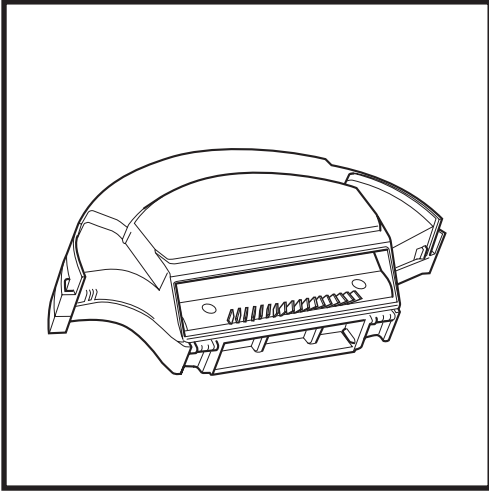

Remove and empty the dust bin. Clean any hair or debris off the **Anti-Tangle Comb** on the back of the dust bin.

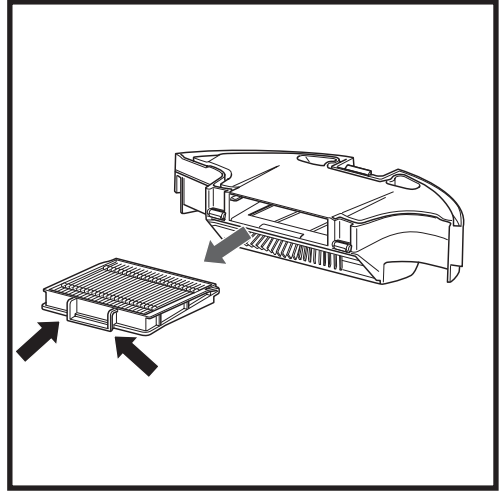

Pull filter out of the dust bin by the tabs.

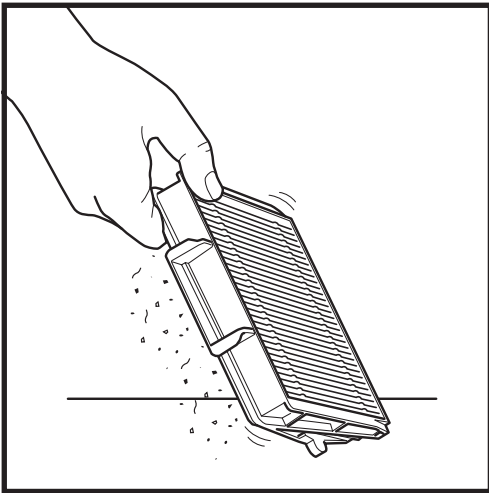

Lightly tap the filter to remove debris every time you empty the dust bin. For a deeper clean, rinse the filter with water once a month. Allow the filter to air-dry for up to 24 hours before reinstalling.

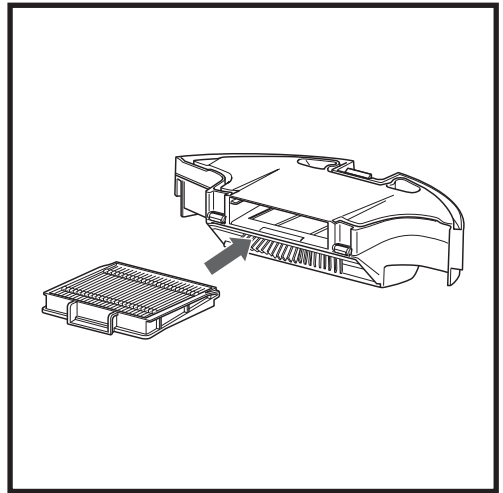

Reinsert the filter into the dust bin, then slide the dust bin back into the robot until it clicks into place.

MAINTENANCE

SELF-CLEANING BRUSHROLL

The **Self-Cleaning Brushroll** actively removes hair wrap while your robot cleans. If some debris remains wrapped around the brushroll, continue to run the robot to give the brushroll time to clean itself. If some hair wrap or debris remains after continued cleaning, carefully remove it from the brushroll.

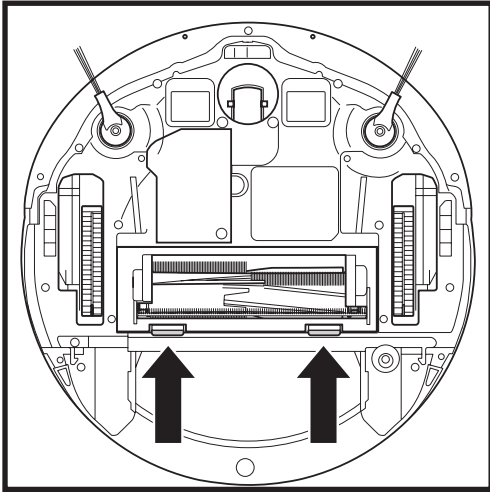

To access the brushroll, push up on the tabs on the brushroll door, then lift off the door.

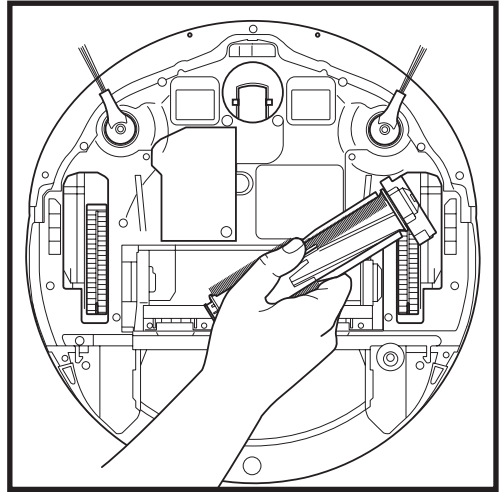

Lift out the brushroll and remove any debris.

Reinstall the brushroll, inserting the flat end first. Close the brushroll access door and press down until both sides click into place.

NOTE: Replace brushroll every 6 to 12 months, or when visibly worn. See sharkaccessories.com for replacement parts.

MAINTENANCE

CLEANING SENSORS AND CHARGING CONTACTS

CLEAN SENSORS AND CHARGING CONTACTS AS NEEDED. With a dry cloth, gently dust off the sensors and contacts located on the bottom of the robot and on the dock.

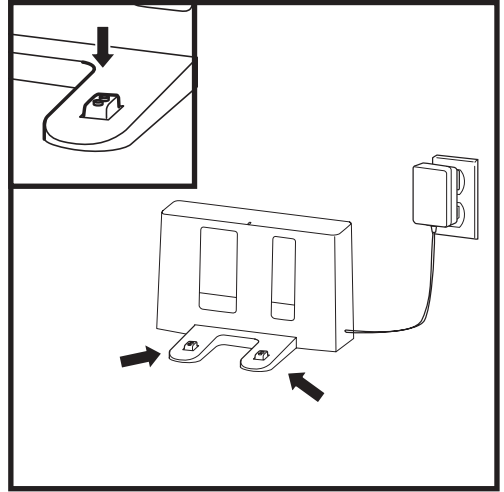
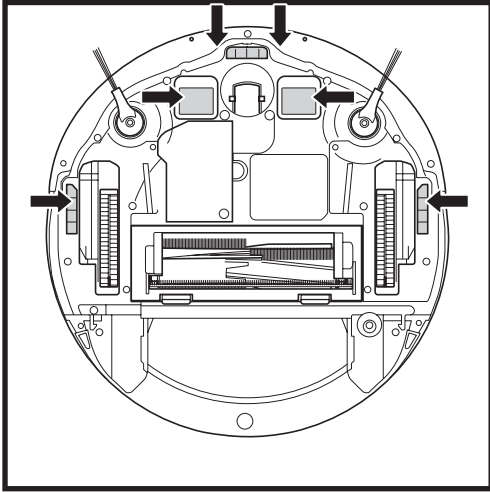

IMPORTANT: The robot uses cliff sensors to avoid stairs and other steep drops. Sensors may work less effectively when they are dirty. For best results, clean sensors regularly.

CLEANING SIDE BRUSHES

CLEAN SIDE BRUSHES AS NEEDED.

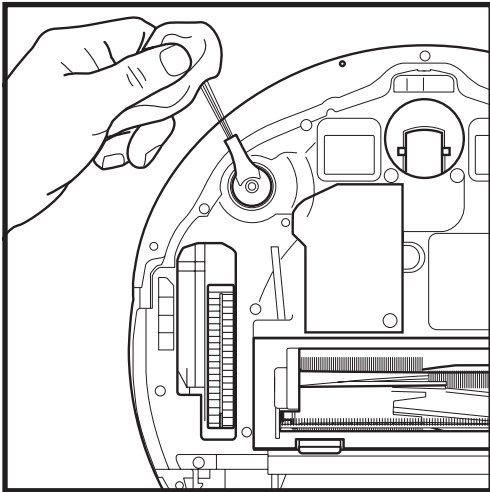

Carefully unwind and remove any string or hair wrapped around brushes.

Gently wipe brushes with a dry cloth. To reinstall, snap the brushes over the pegs. Spin the brushes manually to make sure they are installed correctly.

NOTE: Remove and replace any side brushes that are bent or damaged. To remove a brush, lift it off its peg.

MAINTENANCE

CLEANING THE WHEELS

CLEAN FRONT WHEEL HOUSING PERIODICALLY.

See sharkaccessories.com for replacement parts.

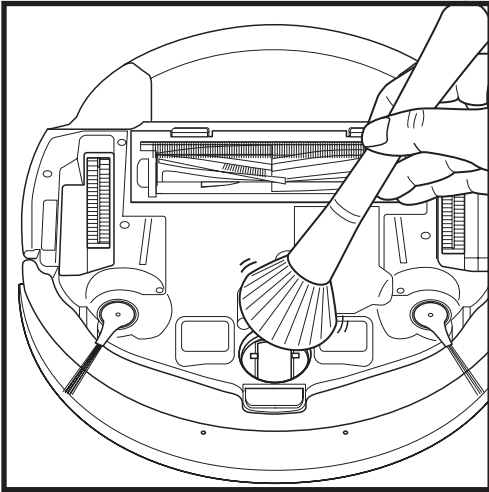

Rotate the front wheel while lightly brushing away dirt and debris. Clean the wheel and the housing around it.

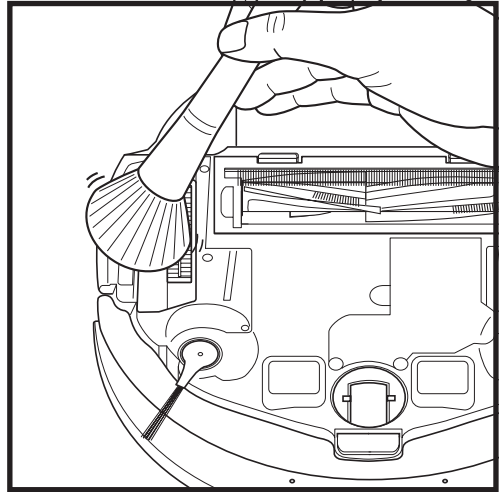

Periodically clean the drive wheels and the housing around them. To clean, rotate each drive wheel while dusting.

NOTE: Brush not included.

REPLACEMENT PARTS

NOTE: To order replacement parts and filters, visit sharkaccessories.com.

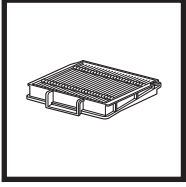

Washable Filter

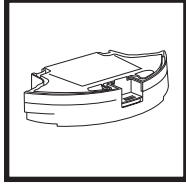

Robot Dust Bin

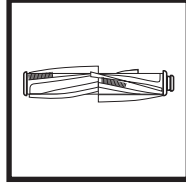

Brushroll

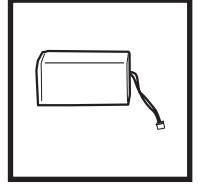

Battery

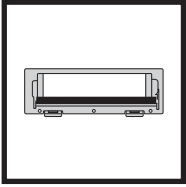

Brushroll Door

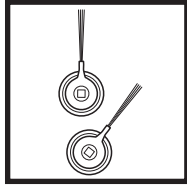

Side Brushes

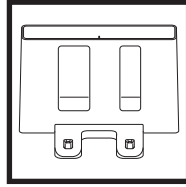

Charging Dock

MAINTENANCE

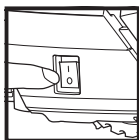

CAUTION: Turn off power before performing any maintenance.

TROUBLESHOOTING

If any error lights are illuminated or flashing on your Shark® AI Robot, see the error code chart below:

ERROR CODE	SOLUTION
CLEAN (RED) + ! (RED) flashing	Suction motor failure. Remove and empty the dust bin, clean the filters, and remove blockages to ensure nothing is reducing suction.
CLEAN (RED) flashing	Robot may be stuck on an obstacle. Move robot to a new location on a level surface.
DOCK (RED) flashing	Front bumper may be jammed. Clean the bumper and make sure it moves in and out freely.
CLEAN (WHITE) + DOCK (RED) solid	BotBoundary® error. Move your robot to a flat surface away from the magnetic boundary strip and try cleaning again.
CLEAN (RED) + DOCK (WHITE) flashing	Cliff sensor error. Move your robot to a new location and clean its cliff sensors.
CLEAN (RED) + DOCK (RED) flashing	Robot dust bin has been removed and needs to be reinserted.
DOCK (RED) + ! (RED) flashing	Side brush is stuck. Remove any debris from around the side brushes.
CLEAN (RED) + DOCK (RED) + ! (RED) flashing	A drive wheel is stuck. Clean the wheels and remove any debris wrapped around the axles.
CLEAN (WHITE) + DOCK (RED) + ! (RED) flashing	Wheel motor encoder failure. Please turn the power off and back on.
CLEAN (WHITE) + ! (RED) flashing	Blockage in brushroll. Remove any debris from around the brushroll.
CLEAN (RED) + DOCK (WHITE) + ! (RED) flashing	Robot has encountered an error while booting. Please turn the power off and back on.
CLEAN (WHITE) + DOCK (RED) flashing	Robot cannot locate dock. Please pick up your robot and place it on the dock.
BATTERY ICON (RED) flashing	Battery is critically low and needs recharging. If your robot is unable to dock, place the robot manually on the dock.
CLEAN (RED) + DOCK (WHITE) flashing + ! (RED)	Robot is stuck. Please move to a level surface.

For all other issues, please call Customer Service at 1-888-668-9600.

END-USER LICENSE AGREEMENT FOR SHARKNINJA SOFTWARE

IMPORTANT: PLEASE READ THE TERMS AND CONDITIONS OF THIS LICENSE AGREEMENT CAREFULLY BEFORE CONTINUING WITH THIS PROGRAM INSTALL OR USE OF THIS PRODUCT: SharkNinja Operating LLC's ("SharkNinja") End-User License Agreement ("EULA") is a legal agreement between You (either a single entity or an individual) and SharkNinja for SharkNinja's Software Applications, including those installed by You onto your SharkNinja products or already installed on your device, including all firmware (referred hereafter as "SN APPS"). By installing, copying, checking a box, clicking a button confirming your agreement to these terms, or otherwise continuing to use the SN APPS, You agree to be bound by the terms of this EULA. This license agreement represents the entire agreement concerning SN APPS between You and SharkNinja, and it supersedes any prior proposal, representation, or understanding between the parties. If You do not agree to the terms of this EULA, do not install or use the SN APPS or this product. The SN APPS are protected by copyright laws and international copyright treaties, as well as other intellectual property laws and treaties.

1. GRANT OF LICENSE. The SN APPS are licensed as follows:

- 1.1 Installation and Use. SharkNinja grants You the right to download, install, and use SN APPS on the specified platform for which the SN APP was designed and in connection with SharkNinja products with which the SN APPS are designed to operate ("SN Devices").
- 1.2 Backup Copies. You may also make a copy of SN APPS downloaded and installed by You for backup and archival purposes.

2. DESCRIPTION OF OTHER RIGHTS AND LIMITATIONS.

- 2.1 Maintenance of Copyright Notices. You must not remove or alter any copyright notices on any and all copies of the SN APPS.
- 2.2 Distribution. You may not distribute copies of the SN APPS to third parties.
- 2.3 Prohibition on Reverse Engineering, Decompilation, and Disassembly. You may not reverse engineer, decompile, or disassemble SN APPS, except and only to the extent that such activity is expressly permitted by applicable law notwithstanding this limitation.
- 2.4 Rental. You may not rent, lease, or lend SN APPS without written permission from SharkNinja.
- 2.5 NOT FOR RESALE SOFTWARE. Applications identified as "Not for Resale" or "NFR," may not be resold, transferred, or used for any purpose other than demonstration, test, or evaluation.
- 2.6 Support Services. SharkNinja may provide You with support services related to SN APPS ("Support Services"). Any supplemental software code provided to You as part of the Support Services shall be considered part of SN APPS and subject to the terms and conditions of this EULA.
- 2.7 Compliance with Applicable Laws. You must comply with all applicable laws regarding use of SN APPS.

3. UPDATES. SharkNinja may provide You with upgrades or updates to SN APPS. This EULA will govern any upgrades provided by SharkNinja that replace and/or supplement SN APPS, unless such upgrade is accompanied by a separate EULA, in which case the terms of that EULA will govern. If You decide not to download and use an upgrade or update provided by SharkNinja, You understand that You could put SN Apps at risk to serious security threats or cause SN Apps to become unusable or unstable.

4. DATA AND PRIVACY. SharkNinja is committed to ensuring your privacy by adhering to high standards of fairness and integrity. We are committed to keeping our customers informed about how we use the information we gather from You through the use of each of our websites or SN APPS. Our privacy practices are described in SharkNinja's Privacy Policy, as well as in separate notices given when an app, product, or service is purchased or downloaded. By using SN APPS or providing us with your personal information, You are accepting and consenting to the practices, terms, and conditions described in SharkNinja's Privacy Policy. At all times your information will be treated in accordance with the SharkNinja Privacy Policy, which is incorporated by reference into this EULA and can be viewed at the following URL:
<http://www.sharkninja.com/privacypolicy>.

5. THIRD-PARTY APPLICATION LIBRARIES AND EMBEDDED SOFTWARE.

- 5.1 You acknowledge that Amazon Web Services, Inc. ("AWS") has provided certain application libraries that have been embedded into SN APPS ("AWS Application Libraries") and enables SN Devices to connect to the AWS Cloud Service ("AWS Embedded Software").
- 5.2 You will not use the AWS Application Libraries except as an incorporated portion of SN APPS, unmodified from the form provided to You.
- 5.3 You will not use the AWS Embedded Software except as an incorporated portion of SN Devices, unmodified from the form provided to You.
- 5.4 You will not modify, adapt, translate, or create derivative works based on, or decompile, disassemble, reverse engineer, or otherwise attempt to derive the source code or underlying algorithms of, the AWS Application Libraries or the AWS Embedded Software.
- 5.5 SharkNinja retains all ownership of SN APPS (and the AWS Application Libraries contained therein) and any software installed on SN Devices (including the AWS Embedded Software) and only a license thereto is granted to You for use in connection with the SN APPS and SN Devices.

END-USER LICENSE AGREEMENT FOR SHARKNINJA SOFTWARE

5.6 You will not use the AWS Application Libraries or AWS Embedded Software to attempt to gain unauthorized access to or use of the systems/services of SharkNinja's other licensors; nor will You transmit viruses, worms, Trojan horses, time bombs, spyware, malware, cancelbots, passive collection mechanisms, robots, data mining software, or any other malicious or invasive code or program into the systems/services of SharkNinja's other licensors.

5.7 You will not use the AWS Application Libraries or AWS Embedded Software to interfere with, breach, or circumvent any security feature, authentication feature, or any other feature that restricts or enforces limitations on the use of, or access to, the systems/services of SharkNinja's other licensors.

5.8 You will not probe, attack, scan, or test the vulnerability of the systems/services of SharkNinja's other licensors.

5.9 SharkNinja's other licensors of the SN APPS, AWS Application Libraries, and the AWS Embedded Software are the express third-party beneficiaries of this EULA, and the provisions of this Section of this EULA are made expressly for the benefit of such licensors, and are enforceable by such licensors.

6. TERMINATION. Without prejudice to any other rights, SharkNinja may terminate this EULA if You fail to comply with the terms and conditions of this EULA. In such event, You must destroy all copies of SN APPS in your possession.

7. COPYRIGHT. All title, including but not limited to copyrights, in and to SN APPS and any copies thereof are owned by SharkNinja or its suppliers. All title and intellectual property rights in and to the content which may be accessed through use of SN APPS are the property of the respective content owner and may be protected by applicable copyright or other intellectual property laws and treaties. This EULA grants You no rights to use such content. All rights not expressly granted are reserved by SharkNinja.

8. OPEN SOURCE SOFTWARE. You hereby acknowledge that SN APPS may contain software that is subject to "open source" or "free software" licenses ("Open Source Software"). The license granted by this EULA does not apply to Open Source Software contained in the SN APPS. Rather, the terms and conditions in the applicable Open Source Software license shall apply to the Open Source Software. Nothing in this EULA limits your rights under, or grants You rights that supersede, any Open Source Software license. You acknowledge that the Open Source Software license is solely between You and the applicable licensor of the Open Source Software. To the extent the terms of the licenses applicable to the Open Source Software require SharkNinja to provide the Open Source Software, in either source or executable form, or to provide copies of applicable license terms or other required information, You may obtain a copy of the software by contacting SharkNinja at the below physical address. Additional information about the Open Source Software, and its terms of use, may be found at www.sharkclean.com/opensource.

9. NO WARRANTIES. SharkNinja expressly disclaims any warranty for SN APPS, AWS Application Libraries, or AWS Embedded Software. SN APPS, AWS Application Libraries, and AWS Embedded Software are provided 'As Is' without any express or implied warranty of any kind, including but not limited to any warranties of merchantability, noninfringement, fitness of a particular purpose, or title. SharkNinja does not warrant or assume responsibility for the accuracy or completeness of any information, text, graphics, links, or other items contained within the SN APPS. SharkNinja makes no warranties respecting any harm that may be caused by the transmission of a computer virus, worm, logic bomb, or other such computer program. SharkNinja further expressly disclaims any warranty or representation to any third party.

10. LIMITATION OF LIABILITY. In no event shall SharkNinja or its suppliers be liable for any special, incidental, punitive, indirect, or consequential damages whatsoever (including, but not limited to, damages for loss of profits or confidential or other information, for business interruption, for personal injury, for loss of privacy, for failure to meet any duty including of good faith or of reasonable care, for negligence, and for any other pecuniary or other loss whatsoever) arising out of or in any way related to the use of or inability to use SN Devices or SN APPS, the provision of or failure to provide support or other services, information, software, and related content through the product or otherwise arising out of the use of SN APPS, or otherwise under or in connection with any provision of this EULA, even in the event of the fault, tort (including negligence), strict liability, breach of contract, or breach of warranty of SharkNinja or any supplier, and even if SharkNinja or any supplier has been advised of the possibility of such damages. SharkNinja shall have no liability with respect to the content of the SN APPS or any part thereof, including but not limited to errors or omissions contained therein, libel, infringements of rights of publicity, privacy, trademark rights, business interruption, personal injury, loss of privacy, moral rights, or the disclosure of confidential information.

11. APPLICABLE LAW. The laws of the Commonwealth of Massachusetts will govern this EULA and You hereby consent to exclusive jurisdiction and venue in the state and federal courts sitting in the Commonwealth of Massachusetts.

12. ASSIGNMENT. SharkNinja may assign this EULA without notice to Licensor.

13. ENTIRE AGREEMENT. This EULA (including any addendum or amendment to this EULA which is included with the SN Devices) is the entire agreement between You and SharkNinja relating to the SN APPS and supersedes all prior or contemporaneous oral or written communications, proposals and representations with respect to the SN APPS or any other subject matter covered by this EULA. To the extent the terms of any SharkNinja policies or programs for support services conflict with the terms of this EULA, the terms of this EULA shall control.

If You have questions regarding this EULA, please contact SharkNinja at 89 A Street, Suite 100, Needham, MA 02494.

ONE (1) YEAR LIMITED WARRANTY

The One (1) Year Limited Warranty applies to purchases made from authorized retailers of **SharkNinja Operating LLC**. Warranty coverage applies to the original owner and to the original product only and is not transferable.

SharkNinja warrants that the unit shall be free from defects in material and workmanship for a period of one (1) year from the date of purchase when it is used under normal household conditions and maintained according to the requirements outlined in the Owner's Guide, subject to the following conditions and exclusions:

CALIFORNIA RESIDENTS ONLY: The one (1) Year Limited Warranty period begins on the original date of delivery or pick-up.

What is covered by this warranty?

1. The original unit and/or non-wearable components deemed defective, in SharkNinja's sole discretion, will be repaired or replaced up to one (1) year from the original purchase date.
2. In the event a replacement unit is issued, the warranty coverage ends six (6) months following the receipt date of the replacement unit or the remainder of the existing warranty, whichever is later. SharkNinja reserves the right to replace the unit with one of equal or greater value.

What is not covered by this warranty?

1. Normal wear and tear of wearable parts (such as foam filters, filters, etc.), which require regular maintenance and/or replacement to ensure the proper functioning of your unit, are not covered by this warranty. Replacement parts are available for purchase at **sharkaccessories.com**.
2. Any unit that has been tampered with or used for commercial purposes.
3. Damage caused by misuse (e.g., vacuuming up water or other liquids), abuse, negligent handling, failure to perform required maintenance (e.g., not cleaning the filters), or damage due to mishandling in transit.
4. Consequential and incidental damages.
5. Defects caused by repair persons not authorized by SharkNinja. These defects include damages caused in the process of shipping, altering, or repairing the SharkNinja product (or any of its parts) when the repair is performed by a repair person not authorized by SharkNinja.
6. Products purchased, used, or operated outside North America.

How to get service

If your appliance fails to operate properly while in use under normal household conditions within the warranty period, visit **sharkclean.com/support** for product care and maintenance self-help. Our Customer Service Specialists are also available at **1-888-668-9600** to assist with product support and warranty service options, including the possibility of upgrading to our VIP warranty service options for select product categories. Please register your product and have it with you when contacting Customer Service.

SharkNinja will cover the cost for the customer to send in the unit to us for repair or replacement. A fee of \$24.95 (subject to change) will be charged when SharkNinja ships the repaired or replacement unit.

How to initiate a warranty claim

You must call **1-888-668-9600** to initiate a warranty claim. You will need the receipt as proof of purchase. A Customer Service Specialist will provide you with return and packing instruction information.

How state law applies

This warranty gives you specific legal rights, and you also may have other rights that vary from state to state. Some states do not permit the exclusion or limitation of incidental or consequential damages, so the above may not apply to you.

WARRANTY COVERAGE OVERVIEW

Covered by Warranty

- Manufacturing defects
- Internal hardware or software malfunctions
- Structural failures due to poor workmanship

Not Covered by Warranty

- Damage from misuse, accidents, or unauthorized repairs
- Normal wear and tear
- Wearable parts (unless defective upon first use)

Wearable vs. Non-Wearable Parts

Category	Definition
Wearable Parts	Components that naturally degrade over time due to regular use and friction.
Non-Wearable Parts	Core components not expected to degrade under normal use within warranty period.

Robot Vacuum Parts, Maintenance, and Replacement Guide

Part	Category	Maintenance	Replacement Recommendation	Warranty Coverage
Brushroll	Wearable	Clean weekly	Every 6–12 months	No (unless defective)
Side Brush	Wearable	Clean bi-weekly	Every 3–6 months	No (unless defective)
Filters	Wearable	Clean monthly	Every 2–3 months	No
Dust Bin	Wearable	Empty after each use	As needed	No (unless defective)
Mop Pad (if applicable)	Wearable	Wash after each use	Every 3–6 months	No
Battery	Wearable	Avoid full discharges	Every 12–24 months	Yes (within warranty)
Wheels	Wearable	Check for debris monthly	As needed	No (unless defective)
Water Tanks	Wearable	Clean monthly	As needed	No (unless defective)
Ramp	Wearable	Clean monthly	As needed	No (unless defective)
Charging Dock	Non-Wearable	Keep clean and dry	N/A	Yes
Power Adapter	Non-Wearable	Avoid power surges	N/A	Yes
Pod	Non-Wearable	Wipe clean monthly	N/A	Yes

REGISTER YOUR PURCHASE



registryourshark.com



RECORD THIS INFORMATION

Model Number: _____

Date Code: _____

Date of Purchase: _____
(Keep receipt)

Store of Purchase: _____

TIP: You can find the model and serial numbers on the QR code labels on the bottom of the robot and battery.

EXPECTED PERFORMANCE

Expected runtime: 60 minutes

Expected charging time: 6 hours



FCC WARNINGS

This equipment has been tested and found to comply with the limits for a Class B digital device, pursuant to parts 15 of the FCC Rules. These limits are designed to provide reasonable protection against harmful interference in a residential installation. This equipment generates, uses, and can radiate radio frequency energy and, if not installed and accordance with the instructions, may cause harmful interference to radio communications. However, there is no guarantee that interference will not occur in a particular installation. If this equipment does cause harmful interference to radio or television reception, which can be determined by turning the equipment off and on, the user is encouraged to try to correct the interference by one or more of the following measures:

- Reorient or relocate the receiving antenna.
- Increase the separation between the equipment and receiver.
- Connect the equipment into an outlet on a circuit different from that to which the receiver is connected.
- Consult the dealer or an experienced radio/TV technician for help.

This Device complies with part 15 of the FCC rules. Operation is subject to the following conditions:

1 This device may not cause harmful interference

2 This device must accept any interference received, including interference that may cause undesired operation.

Changes or modifications not expressly approved by the party responsible for compliance could void the user's authority to operate this device.



BATTERY REMOVAL AND DISPOSAL

This product uses a battery. When the battery no longer holds a charge, it should be removed from the vacuum and recycled. **DO NOT** incinerate or compost the battery.

When your lithium-ion battery needs to be replaced, dispose of it or recycle it in accordance with local ordinances or regulations. In some areas, it is illegal to place spent lithium-ion batteries in the trash or in a municipal solid waste stream. Return spent battery to an authorized recycling center or to retailer for recycling. Contact your local recycling center for information on where to drop off the spent battery.

For more information on battery removal for disposal, please visit sharkclean.com/batterysupport.

The RBRC™ (Rechargeable Battery Recycling Corporation) seal on the lithium-ion battery indicates that the costs to recycle the battery at the end of its useful life have already been paid by SharkNinja. In some areas, it is illegal to place spent lithium-ion batteries in the trash or municipal solid waste stream and the RBRC program provides an environmentally conscious alternative.

RBRC, in cooperation with SharkNinja and other battery users, has established programs in the United States and Canada to facilitate the collection of spent lithium-ion batteries. Help protect our environment and conserve natural resources by returning the spent lithium-ion battery to an authorized SharkNinja service center or to your local retailer for recycling. You may also contact your local recycling center for information on where to drop off the spent battery, or call 1-800-798-7398.

NOTES

NOTES

NOTES

PLEASE READ CAREFULLY AND KEEP FOR FUTURE REFERENCE.

This Owner’s Guide is designed to help you keep your Shark® AI Robot running at peak performance.

SharkNinja Operating LLC
US: Needham, MA 02494
CAN: Ville St-Laurent, QC H4S 1A7
1-888-668-9600
sharkclean.com

Illustrations may differ from actual product. We are constantly striving to improve our products; therefore the specifications contained herein are subject to change without notice.

For SharkNinja U.S. Patent information, visit sharkninja.com/uspatents

© 2025 SharkNinja Operating LLC. BOTBOUNDARY and SHARK are registered trademarks of SharkNinja Operating LLC. IQ NAVIGATION and SHARKCLEAN are trademarks of SharkNinja Operating LLC. RBRC is a trademark of Rechargeable Battery Recycling Corporation. APPLE, the Apple logo, and iPhone are trademarks of Apple Inc., registered in the U.S. and other countries. APP STORE is a service mark of Apple Inc., registered in the U.S. and other countries. GOOGLE, GOOGLE ASSISTANT, GOOGLE PLAY, the Google Play logo, and Android are trademarks of GOOGLE LLC.



@sharkcleaning