

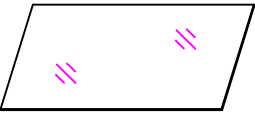

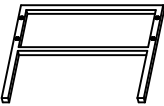



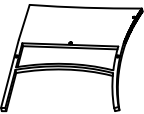

ASSEMBLY INSTRUCTION

PACKING LIST

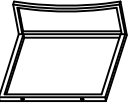
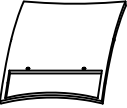
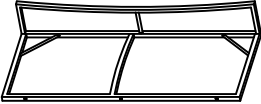
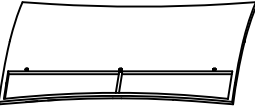
A	TABLE GLASS		1PC
B	TABLE ARM		2PCS
C	TABLE SHELF		2PCS
D	LEFT ARM		3PCS
E	RIGHT ARM		3PCS
F	CHAIR SEAT		2PCS
G	CHAIR BACK		2PCS
H	LOVESEAT SEAT		1PC
I	LOVESEAT BACK		1PC
J	BOLT	 M6x35mm	39PCS
K	METAL WASHER		39PCS
L	ALLEN WRENCH		1PC

COFFEE TABLE

STEP1

Connect B and C, with bolt(J) metal washer(K) and allen wrench(L).

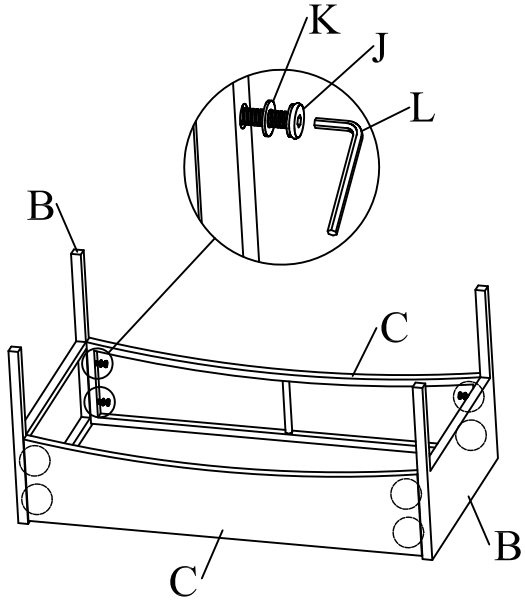

STEP2

Put A on it.

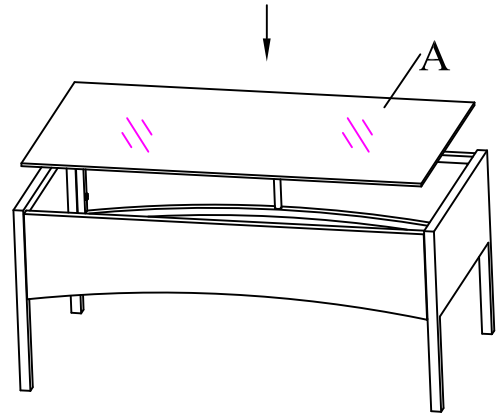

STEP3

Finished.

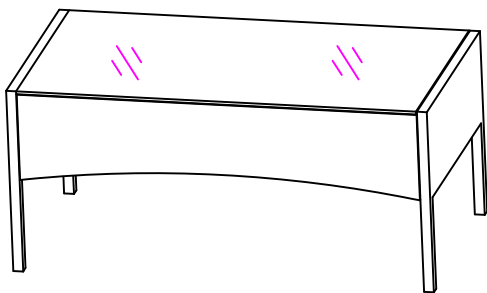

SINGLE CHAIR

STEP1

Connect F and D(E), with bolt(J) metal washer(K) and allen wrench(L).

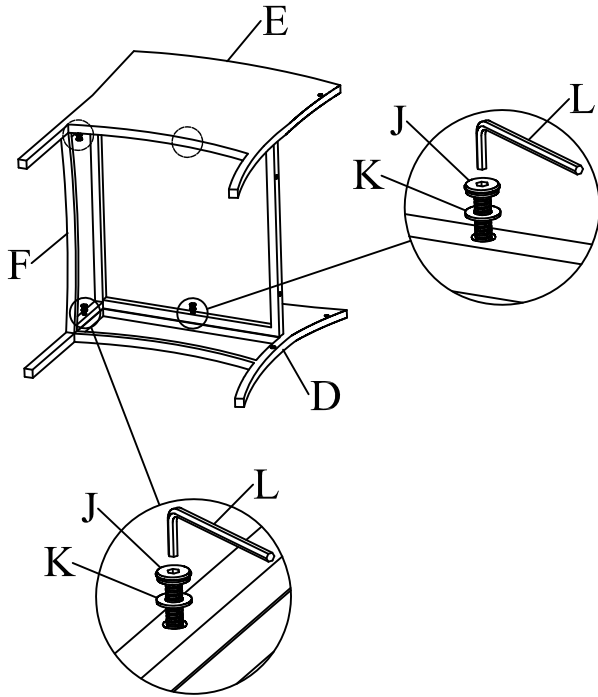

STEP2

Connect G and F(D,E), with bolt(J) metal washer(K) and allen wrench(L).

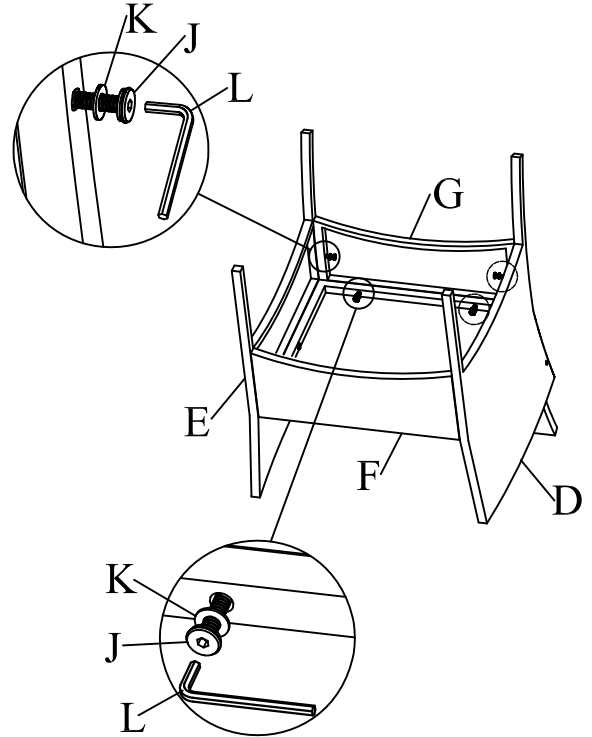

STEP3

Connect G and D(E), with bolt(J) metal washer(K) and allen wrench(L).

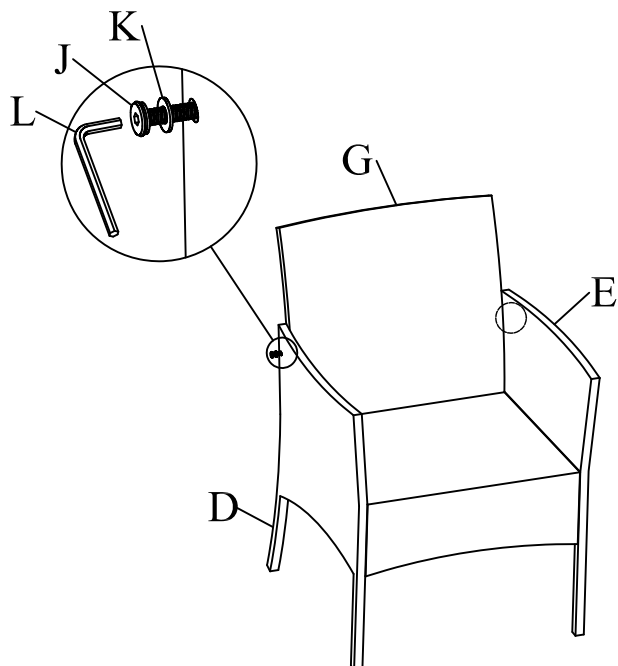

STEP4

Finished.

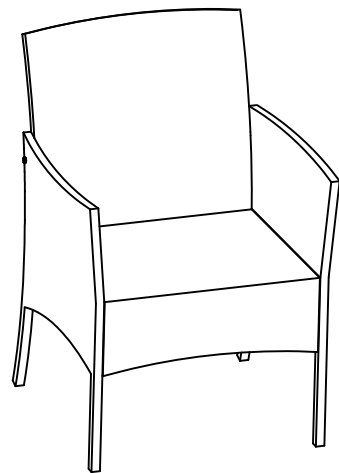

LOVESEAT CHAIR

STEP1

Connect H and D(E), with bolt(J) metal washer(K) and allen wrench(L).

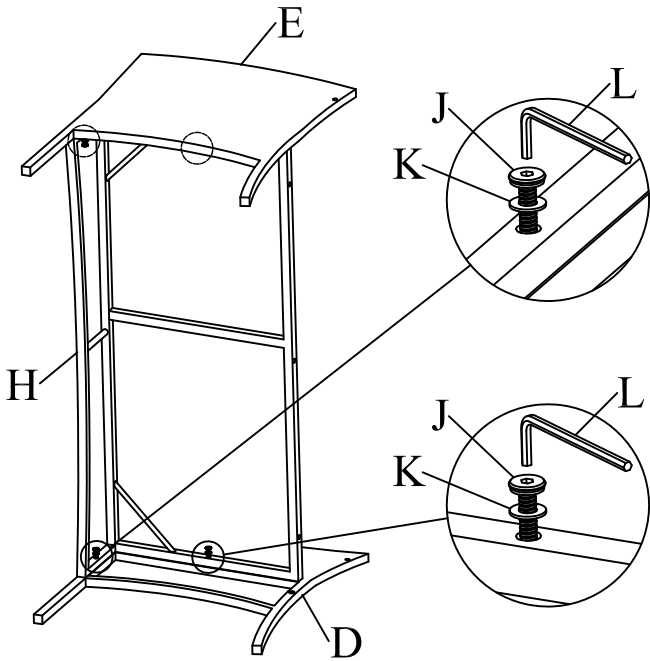

STEP2

Connect I and H(D,E), with bolt(J) metal washer(K) and allen wrench(L).

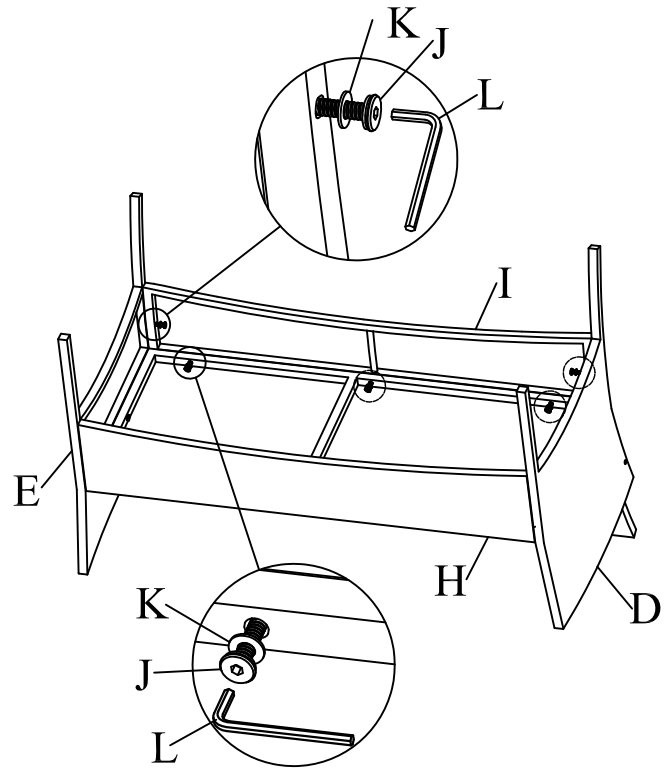

STEP3

Connect I and D(E), with bolt(J) metal washer(K) and allen wrench(L).

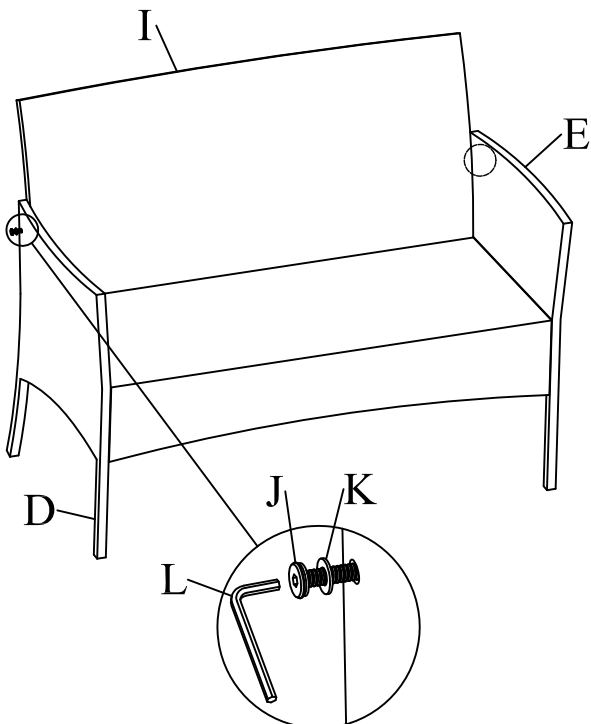

STEP4

Finished.

